

# Pneumatic Actuator Products

Cylinders, Guided Cylinders and Rotary Actuators

Catalog 0900P-7

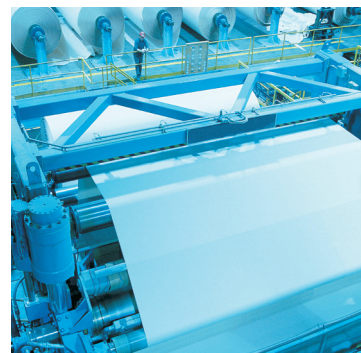

ENGINEERING YOUR SUCCESS.

**Warning, Offer of Sale**

---

 **WARNING**

**FAILURE OR IMPROPER SELECTION OR IMPROPER USE OF THE PRODUCTS AND/OR SYSTEMS DESCRIBED HEREIN OR RELATED ITEMS CAN CAUSE DEATH, PERSONAL INJURY AND PROPERTY DAMAGE.**

This document and other information from Parker Hannifin Corporation, its subsidiaries and authorized distributors provide product and/or system options for further investigation by users having technical expertise. It is important that you analyze all aspects of your application including consequences of any failure, and review the information concerning the product or system in the current product catalog. Due to the variety of operating conditions and applications for these products or systems, the user, through its own analysis and testing, is solely responsible for making the final selection of the products and systems and assuring that all performance, safety and warning requirements of the application are met. The products described herein, including without limitation, product features, specifications, designs, availability and pricing, are subject to change by Parker Hannifin Corporation and its subsidiaries at any time without notice.

**Offer of Sale**

The items described in this document are hereby offered for sale by Parker Hannifin Corporation, its subsidiaries or its authorized distributors. This offer and its acceptance are governed by the provisions stated on the separate page of this document entitled "Offer of Sale".





<b>Product Index, Virtual Engineer, Application Engineering Data</b>		<b>A</b> Product Index Engineering Data
<b>Tie Rod Cylinders</b>	<i>4MA/4ML Series, 4MAJ Series, ACVB Option, LPSO Option, P1D Series, P1F Series, 2MNR Series</i>	<b>B</b> Tie Rod Cylinders
<b>Round Body Cylinders</b>	<i>SR/SRM Series, SRD/SRDM Series, SRG/SRGM Series, SRX Series, P1A Series, P Series</i>	<b>C</b> Round Body Cylinders
<b>Compact Cylinders</b>	<i>LP/LPM Series</i>	<b>D</b> Compact Cylinders
<b>Guided Cylinders</b>	<i>P5T Series, HB Series, P5E Series</i>	<b>E</b> Guided Cylinders
<b>Automation Products</b>	<i>Grippers, Escapements</i>	<b>F</b> Automation Products
<b>Rodless Cylinders</b>	<i>OSP-P, P1X Series, GDL Series</i>	<b>G</b> Rodless Cylinders
<b>Rotary Actuators</b>	<i>PV Series, PRNA/PRN Series, PTR Series, B671/F672 Series, HP Series</i>	<b>H</b> Rotary Actuators
<b>Air Motors</b>	<i>P1V-S Series</i>	<b>J</b> Air Motors
<b>Actuator Accessories</b>	<i>Linear Alignment Couplers, Flow Controls, PRL Series</i>	<b>K</b> Actuator Accessories
<b>Electronic Sensors</b>	<i>Solid State, Reed and Proximity Sensors</i>	<b>L</b> Electronic Sensors
<b>Industrial Shock Absorbers</b>	<i>Industrial Shock Absorbers (Linear Decelerators)</i>	<b>M</b> Industrial Shock Absorbers
<b>Fax Forms, Part Number Index, Safety Guide, Offer of Sale</b>	<i>Application FAX Forms</i>	<b>N</b> Fax Forms, Safety Guide, Offer of Sale



**A**

Product Index,  
 Virtual Engineer,  
 Engineering Data

Product  
 Index

Virtual  
 Engineer

Engineering  
 Data

## Tie Rod Cylinders

### 4MA / 4ML Series - Flexible NFPA Cylinder



B2

- Bore sizes 1-1/2 through 8 inch
- 20 standard mounting styles
- Pressures up to 250 PSIG
- Temperatures -50°F to 250°F
- Aluminum body construction

### 4MAJ - Rodlock Cylinder



B37

- Bore sizes 1-1/2 through 8 inch
- 17 standard mounting styles
- Pressures up to 100 PSIG
- Temperatures -10°F to 165°F
- Aluminum body construction

### P1D Series - ISO 15552 / ISO 6431



B92

- 5 available for maximum flexibility
- Bore sizes 32mm through 200mm
- 10 standard mounting styles
- Pressures up to 145 PSIG
- Temperatures -10°F to 250°F
- Aluminum body construction

### P1F Series - ISO 15552



B118

- Bore sizes 32mm through 125mm, standard strokes to 2000mm
- Operating pressure (air) 1 to 10 bar
- Magnetic piston standard, adjustable cushions standard
- High temperature option to 150°F
- Low temperature option to -40°F
- Metallic scraper option for harsh environments

### 2MNR Series - Non-Rotating



B144

- Bore sizes 1-1/2 through 4 inch
- 9 standard mounting styles
- Pressures up to 250 PSIG
- Temperatures -10°F to 165°F
- Non-rotating, multi-rod design

## Round Body Cylinders

### SR / SRM / SRD / SRDM Series - Non-Repairable



C2

- Bore sizes 5/16 through 3 inch
- 28 mounting styles
- Pressures up to 250 PSIG
- Temperatures -10°F to 165°F
- Stainless steel body construction

### SRG / SRGM Series - Stainless Caps



C34

- Bore sizes 1-1/16 through 3 inch
- Continuous position feedback
- Pressures up to 150 PSIG
- Temperatures 40°F to 165°F
- Stainless steel body construction

### SRX Series - Position Feedback



C38

- Bore sizes 1-1/16 through 3 inch
- Continuous position feedback
- Pressures up to 150 PSIG
- Temperatures 40°F to 165°F
- Stainless steel body construction

### P1A Series - ISO Non-Repairable



C50

- Bore sizes 10mm through 25mm
- 5 mounting styles
- Pressures up to 145 PSIG
- Temperatures -40°F to 302°F
- Stainless steel body construction

### P Series - Repairable



C58

- Bore sizes 1-1/8 through 4 inch
- 4 mounting styles
- Pressures up to 150 PSIG
- Temperatures -10°F to 250°F
- Aluminum body construction

## Compact Cylinders

### LP / LPM Series - Compact Cylinder



- Bore sizes 9/16 through 4 inch
- 6 mounting styles
- Pressures up to 145 PSIG
- Temperatures -10°F to 200°F
- Aluminum body construction

**D10**

## Guided Cylinders

### P5T Series - Compact Guided



- Bore sizes 16mm through 100mm
- Pressures up to 145 PSIG
- Temperatures 0°F to 250°F
- Aluminum body construction
- Flexible porting: top, rear, side

**E2**

### HB Series - Heavy Duty Guided

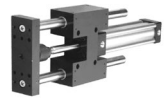

- Bore sizes 1-1/2 through 2-1/2 inch
- Thrust, Reach and Compact versions available
- Air service pressure up to 250 PSIG, hydraulic service up to 750 PSIG
- Temperatures 0°F to 250°F
- Aluminum body construction
- Rod lock version available

**E72**

### P5E Series - P1D ISO Guided



- Bore sizes 32mm through 100mm
- Pressures up to 145 PSIG
- Temperatures 14°F to 165°F
- Aluminum body construction
- Rod lock version available

**E104**

<b>A</b>
Product Index, Virtual Engineer, Engineering Data
Product Index
Virtual Engineer
Engineering Data



**A**

Product Index,  
 Virtual Engineer,  
 Engineering Data

Product  
 Index

Virtual  
 Engineer

Engineering  
 Data

## Automation Products

### Precision Grippers

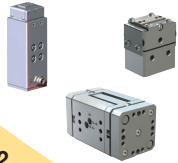

F2

- Premium product for precision and durability
- Repeatability to + 0.00005mm
- Parallel 2 and 3 jaw
- Strokes to 73.5mm
- Grip forces to 44,000 N
- Clean room
- Electric grippers

### Escapement

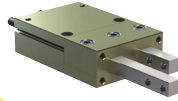

F130

- Most effective mechanism for separating parts fed from conveyor
- Thrust force to 400 N
- Adjustable retract

## Rodless Cylinders

### OSP-P Series - Band Type Rodless

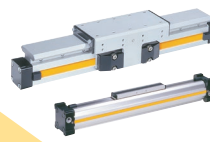

G2

- Bore sizes 10mm through 80mm
- Pressures to max. 8 bar
- Temperatures -10°F to 80°F
- Aluminum body construction

### P1X Series - Band Type Rodless



G98

- 7 bore sizes 16mm through 63mm
- Integral sensor mounting rail
- Pressures 7 to 100 PSIG
- Temperatures 40°F to 140°F
- Aluminum body construction

### GDL Series - Rails & Cassettes



G119

- 6 sizes available
- Speed up to 10m/s (33 ft/s)
- Temperatures -10°C to 80°C
- Aluminum alloy rail
- Aluminum body construction

## Rotary Actuators

### PV Series - Vane Rotary



H3

- 8 model sizes
- Single or double vane models
- Pressures to 150 PSIG
- Temperatures 30°F to 250°F
- 7 to 1800 lb-in output torque

### PRN(A) Series - Vane Rotary



H11

- 5 miniature and 4 standard models
- Temperatures -23°F to 176°F
- 1.33 to 2355 in-lb torque at 100 PSIG

### PTR Series - Rack & Pinion Rotary

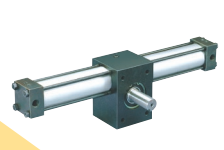

H23

- Bore sizes 1 through 3-1/4 inch
- Pressures to 250 PSIG
- Temperatures 0°F to 250°F
- 39 to 2281 lb-in output torque

### B671/F672 Series - Rack & Pinion Rotary



H38

- Standard Rotations: 90°, 180°, 360°
- Output Torque @ 100 psi: 100 lb-in to 2500 lb-in
- Maximum Break-away Pressure: 10 PSI
- Mounting Orientation: Unrestricted

### HP Series - Large Rack & Pinion Rotary

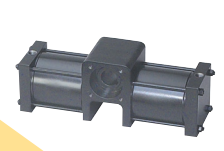

H42

- 2 large bore models
- 3 standard rotations
- Pressures to 100 PSIG
- Temperatures 0°F to 250°F
- 4500 and 10,000 lb-in output at 100 PSIG

## Air Motors

### P1V-S Series - Air Motors

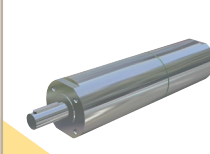

J2

- Power from 20 through 1200 watts
- Speeds 5 to 24,000 RPM
- Pressures to max. 7 bar
- Temperatures -30°C to 100°C

## Actuator Accessories

### Linear Alignment Couplers

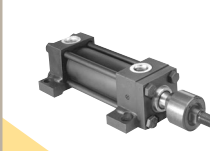

K2

- 12 standard thread sizes
- Maximum reliability for trouble-free operation, long life and lower operating costs
- Increased cylinder life by reducing wear on piston and rod bearings
- Stainless steel versions available

### Flow Controls



K3

- 9 brass right angle flow controls
- 12 blocking valves
- 8 Miniature exhaust flow control valves
- Numerous male global connect fittings and port adapters
- Male and female NPT threaded ports
- Prestolok fittings also available

### PRL Series - Stand Alone Rodlock



K6

- 5 different sizes
- Large holding forces
- 2 different mounting styles
- Case-hardened rod material available

**A**

Product Index,  
 Virtual Engineer,  
 Engineering Data

## Electronic Sensors

### Sensors



- Solid state
- Reed
- NAMUR
- Proximity

L1

## Fax Forms, Part Number Index, Safety Guides, Offer of Sale

- Fax Forms
- Part Number to Page Number Index
- Safety Guide – Actuator Products
- Offer of Sale

N1

Product  
 Index

## Shock Absorbers

### Shock Absorbers



- Miniature - self-compensating
- Heavyweight - soft contact & self-compensating
- Miniature - soft contact & self-compensating
- Magnum series - adjustable
- Heavy - self-compensating
- Heavy - adjustable

M1

Virtual  
 Engineer

Engineering  
 Data





# PNEUMATIC DIVISION E-TOOLS

## Pneumatic Division Part Lookup Tool

### Part Lookup Tool Overview

The purpose of this application is to provide users with more in depth detail, such as replacement kits or current inventory for specific pneumatic part numbers. The tool also provides cross reference information for products that have been previously obsoleted. Searches can be made by searching a portion or all of a part number. Use the drop down options available to narrow your search.



### Part Lookup Tool Contents

- Replacement KITS by part number
- Obsolete cross reference
- Inventory/stock levels
- Pricing (with distributor login only)
- Bulk part search
- Shipping location
- Lead time

### How to access the Tool

U.S. Parker Pneumatic Distributors

- [www.pdnpartlookup.com](http://www.pdnpartlookup.com)
- Or download the “Distributor Toolbox” app



Guest Users

- [www.pdnplu.com](http://www.pdnplu.com)

## Pneumatic Division Size & Selection Calculators

### Size, Selection and Cost of Air Calculators Overview

The purpose of this application is to provide users and designers of pneumatic systems with a handy collection of compressed air cost calculators, conversion tools and air valve (Cv) and flow (SCFM) calculations for air cylinder actuation. The size and select calculators are available to anyone for use. See details below.

### How to access the Tool

- [www.parkerpdncalc.com](http://www.parkerpdncalc.com)
- Or download the “Pneumatics” calculator app

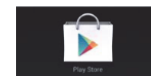
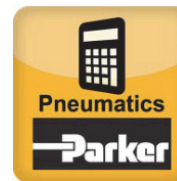

### Calculator Contents

- Cost calculator for leaks
- Cost calculator for compressors
- Cost calculator for reverse flow regulators
- Vacuum flow through an orifice
- Air flow through an orifice
- Annual cost of air cylinder operation
- Valve/FRL sizing for cylinder actuation
- And more!

---

**A**

Product Index,  
Virtual Engineer,  
Engineering Data

Product  
Index

Virtual  
Engineer

Engineering  
Data



For inventory, lead times, and kit  
lookup, visit [www.pdnplu.com](http://www.pdnplu.com)

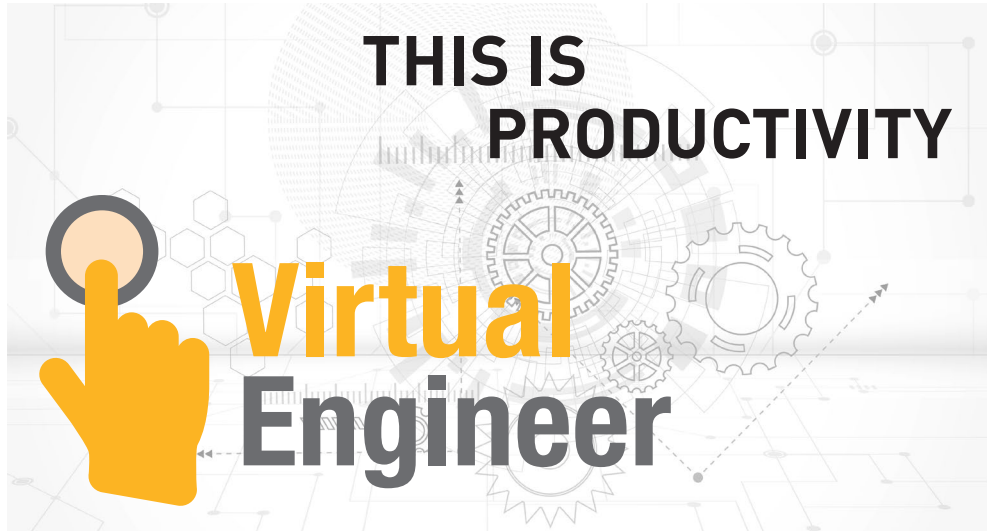

Virtual Engineer is an innovative design tool for Parker pneumatic actuators and valves. The tool is free and open to the public. Please visit <http://solutions.parker.com/virtualEngineer> to begin using the tool today. Log in to save and share your work.

#### Virtual Engineer Work Flow

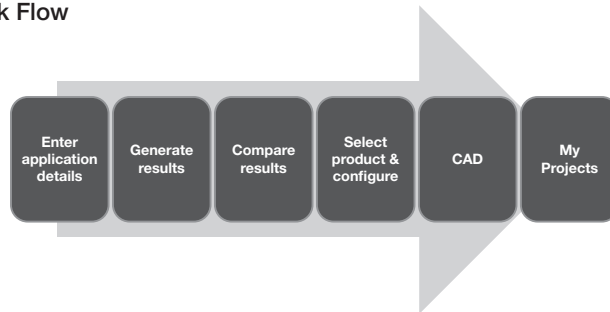

#### Enter application details

You are required to enter a minimum of four inputs, but have the capability of entering as much detail as necessary to capture even the most complex applications

#### Generate results

The physics engine simulates and analyzes all products loaded into the tool and produces a list of every product capable of handling your application.

#### Compare results

Review all products that meet your design requirements. Sort and filter based on criteria that is important to you: price, life, air consumption, valve Cv, and 19 others to choose from.

#### Select product & configure

Select a product from the compare table and you are automatically routed to an online configurator where you can complete the part number.

#### CAD

After completing the part number click CAD and download from the extensive list of CAD formats.

#### My projects

Save your work. Share projects and systems internally and externally to your organization.



**A**

## Step 1

Visit [solutions.parker.com/virtualEngineer](https://solutions.parker.com/virtualEngineer)

Product Index,  
Virtual Engineer,  
Engineering Data

Product  
Index

Virtual  
Engineer

Engineering  
Data

## Step 2

Select desired technology for your application from the main landing page

**A**

### Electromechanical Sizing Tool

Accurately size your electrical actuators in this interactive module.

**B**

### Pneumatic Sizing Tool

Accurately size your pneumatic actuators in this interactive module.

## Selection Made: Pneumatic



For inventory, lead times, and kit lookup, visit [www.pdnplu.com](http://www.pdnplu.com)

### Step 3

Select desired motion

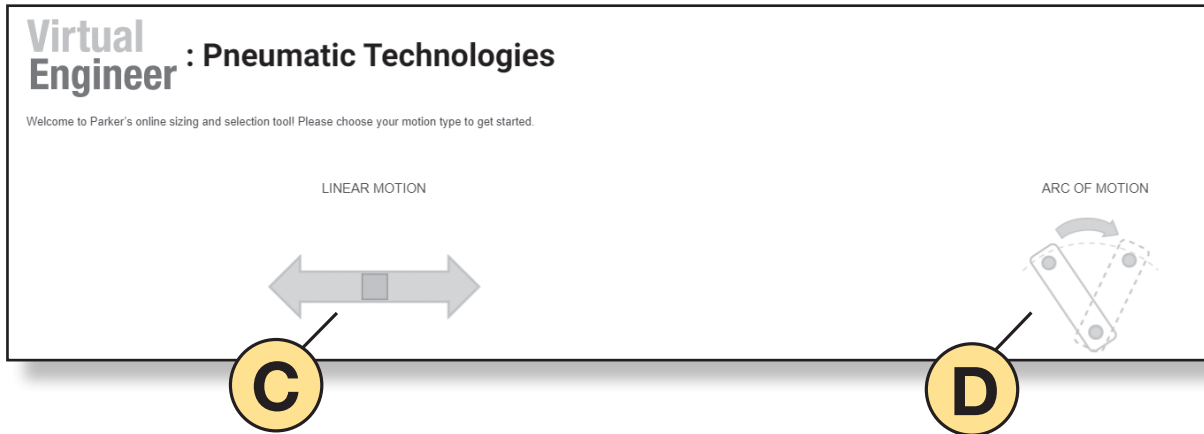

#### Linear Motion Sizing Tool

Select for cylinder applications requiring one-dimensional motion along a straight line.



#### Arc of Motion Sizing Tool

Select for rodless cylinder applications with lever arm rotation less than 180°.

**Selection Made: Linear**

**A**

Product Index,  
Virtual Engineer,  
Engineering Data

Product  
Index

Virtual  
Engineer

Engineering  
Data

## Step 4

Select desired motion

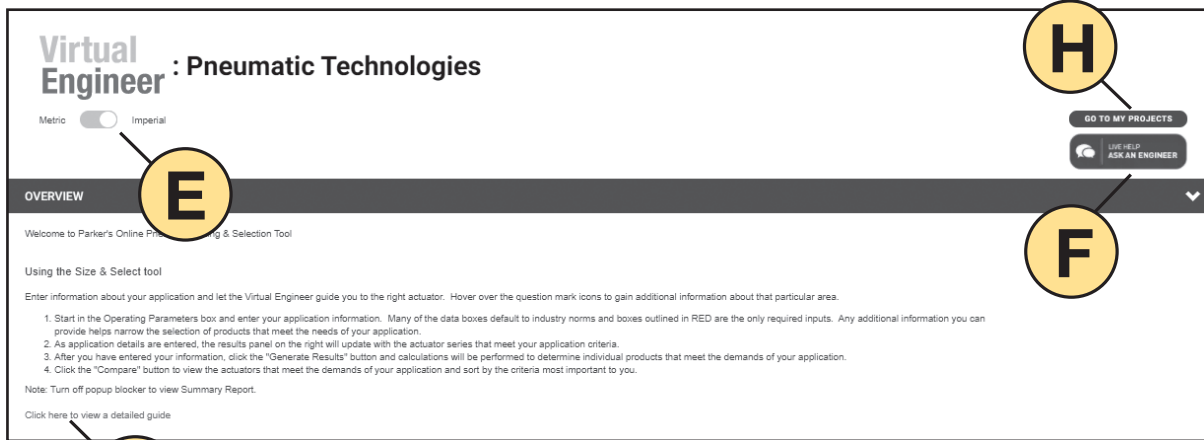

### Metric/Imperial Toggle

Select metric or imperial as the standard for your application details, metric is the default.

\*Beware this module will not convert previously entered values\*



### Ask an Engineer Icon

Directly links to our application engineering support team. If the icon is visible, somebody is online and available to assist.



### Detailed Guide

Once selected, a help document will appear in a new window. This guide contains important notes, definitions, and explanations for using the tool. The guide is a PDF that can be saved for future reference.



### Go To My projects

Log in required to save your work. This allows you to easily update applications based on updated information. You can also the application with anyone that has an e-mail address.



## Step 5

Follow this application example to size multiple linear actuators. Select the most cost effective actuator. The corresponding parameters are listed below:

- Standard operating pressure and temperature (the default values already loaded)
- 30-inch tubing length
- 10 lb tooling plate, with a center of gravity +5 inches in the x axis and +5 inches in the y axis
- 1 million cycles
- 10-inch stroke length
- Double acting
- No external stop
- 5 second extend and 5 second retract, with a 1 second dwell at each end
- External force of 5 lbf acting against tooling plate during extend
- 100 lbf – in roll moment during the extend stroke

The screenshot shows the 'OPERATING PARAMETERS' section of a software interface. It contains several input fields and toggle switches. Callout letters are used to identify specific features: 'I' points to the Operating Pressure field, 'J' points to the metric/imperial toggle switches, 'K' points to the Tubing Length field, and 'L' points to a question mark icon. A red box highlights the Tubing Length field, indicating a required field with a validation message: '\*BEFORE INPUTS\*' and 'Tubing Length must be greater than 0.'

*\*A red box indicates a required field. The user must input a value here to be able to generate and compare results.\* There are 4 required fields.*

- I** **Operating Pressure**  
Gauge pressure required at valve inlet.
- J** **Metric/Imperial Toggle**  
Individual inputs can be changed between metric or imperial without impacting previous inputs.
- K** **Tubing Length**  
The distance from the valve to the actuator.
- L** **Variable**  
click on question mark for details on the variable

## Step 6

Select images that resemble your application

**APPLICATION TYPE**

Step 1: Select spanned or cantilevered.  
 Step 2: Click the appropriate image that closely matches your application  
 Step 3: Select customer-provided load support that matches your application

**Application Type**

  
 Cantilever

  
 Spanned

  
 Pivot

  
 Span

  
 Stopper

**Load attachment**

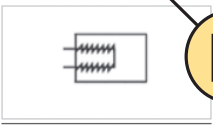
  
 Fixed

  
 Pivot

**Customer-provided load support**

Coefficient of Friction, Load Support

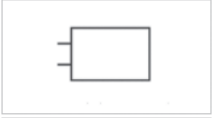
  
 Not Guided or Supported

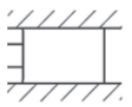
  
 Rigidly Guided

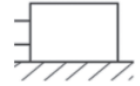
  
 Supported but not Rigidly Guided

- M** **Application Type (Mounting Style)**  
 Cantilevered – The cylinder body is fixed, and actuation takes place outside the cylinder body.  
 Pivot – The cylinder is supported at one end and allowed to pivot.  
 Spanned – The cylinder body is fixed, and the actuation takes place between fixed ends.  
 Stopper – Similar to cantilevered applications, used to stop a moving mass.

- N** **Load Attachment (Rod end)**  
 Fixed – Load is secured at the rod end.  
 Pivot – Load is attached to a pivot mount at the rod end.

- O** **Load Support**  
 Not Guided or Supported – Coefficient of friction automatically set to 0.  
 Rigidly Guided – Load is guided, allowing only linear motion.  
 Supported but not Rigidly Guided – Load is supported with respect to gravity, but otherwise not guided.

## Step 7

Input attached mass and orientation specifics to match your application

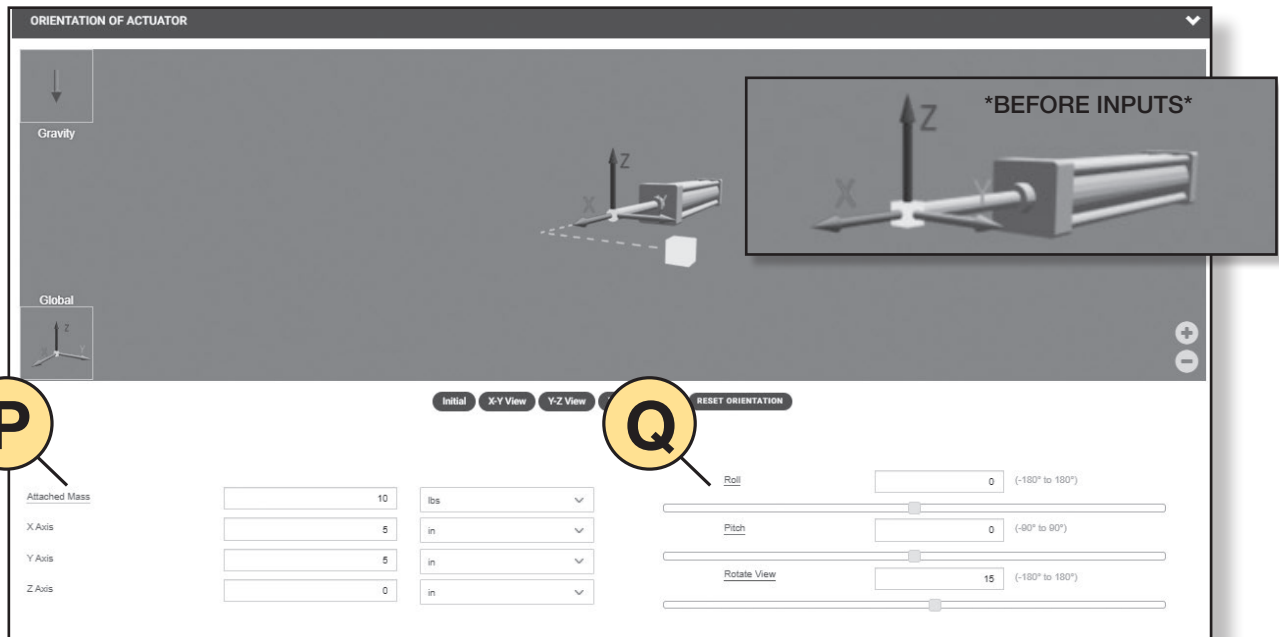

### Attached Mass

Any fixture/device attached and moving along with the actuator during the overall piston cycle (extend & retract). Input offset distances (cylinder to attached mass) by the corresponding axis.

Center of mass for attachments (symbolized as the yellow box) will change position based on information provided.

*\*If a mass moves only during extension or retraction, the corresponding additional attached mass should be entered into the External Forces section below.\**



### Orientation

Roll – The rotation angle around the centerline of the actuator. This is a rotation around the actuator's local X axis.

Pitch – The angle of inclination of the actuator relative to the horizontal. This is a rotation around the global Y axis.

Rotate View – Adjust the view as desired. This input does not affect calculations.

## Step 8

Input desired stroke length as well as extend and retract specifics

- R** **Required Life**  
 Default is 1 M cycles, Virtual Engineer will compare life for all actuators that meet your design requirements, maximum is 20M cycles.
- S** **Stroke Length**  
 Distance the piston travels within the cylinder.
- T** **Extend/Retract Characteristics**  
 Consider whether the desired application is double/single acting.  
 Single acting requires a spring during either extension or retraction.  
 Extend/Retract Time – Define the time to travel the full stroke length in each direction separately. These entries are treated as maximums  
 Dwell – The duration the piston remains still before extending/retracting.
- U** **Time/ Cycles**  
 Cycles per unit of time are automatically calculated from the Extend and Retract inputs as well as the time the application is used in the period of a year.

Hours per day, Days per week and Weeks per year numbers can be changed by user to match their production times, but these inputs do not effect the calculations for bearing life.

**A**  
 Product Index,  
 Virtual Engineer,  
 Engineering Data  

---

 Product  
 Index  

---

 Virtual  
 Engineer  

---

 Engineering  
 Data

## Step 9a

Input external force specifics

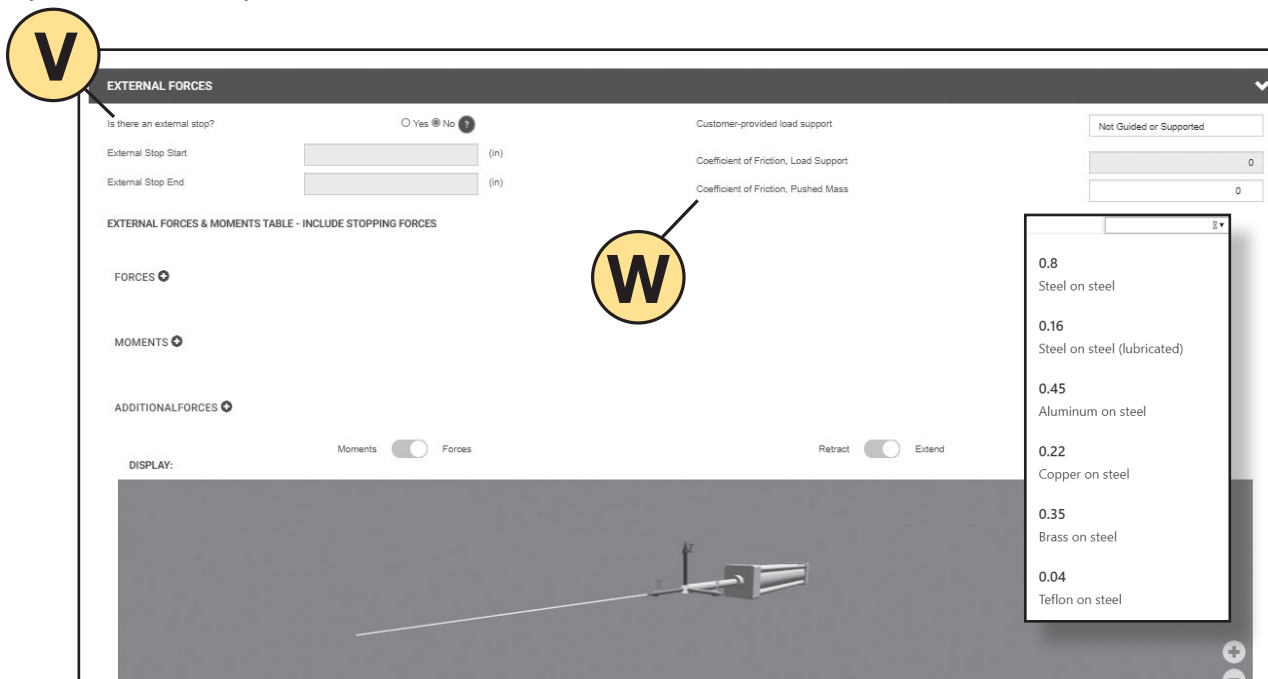

### External Stop

Defined by their distance from the zero-stroke position (fully retracted). Select “?” for examples.



### Coefficient of Friction

Customer-provided Load Support – This field will be prepopulated based on previous selections made in Step 6.

Coefficient of Friction, Load Support – COF of the bearing and guide rail package provided by the customer.

Coefficient of Friction, Pushed Mass – Once selected, from the Additional Forces input below, a drop-down menu with common COF values will appear. This field refers to the COF between the supporting surface and the unattached mass pushed by the actuator. It is unrelated to Load Support.



## Step 9b

Input external force specifics

The screenshot displays three configuration panels for external forces and moments. Each panel includes a table with columns for Start (in), End (in), X (in), Y (in), and Z (in). The FORCES panel shows a Force Type dropdown set to 'Force' and an Action dropdown set to 'Extend'. The MOMENTS panel shows a Moment Type dropdown set to 'Moment' and an Action dropdown set to 'Extend'. The ADDITIONALFORCES panel shows a Spring Type dropdown set to 'Spring' and an Action dropdown set to 'Extend'. The interface also includes 3D visualizations of a piston and a spring.

**X** **Forces**  
 For Start and End criteria consider the piston's position at the time of the applied force(s).

**Y** **Moments**  
 Input any roll, pitch, or yaw moments caused by a pushed or attached mass(es).

**Z** **Additional Forces**  
 Input any force(s) that is produced by springs, actuator pushing a mass or a change to the attached mass.

# Step 10

Input external force specifics

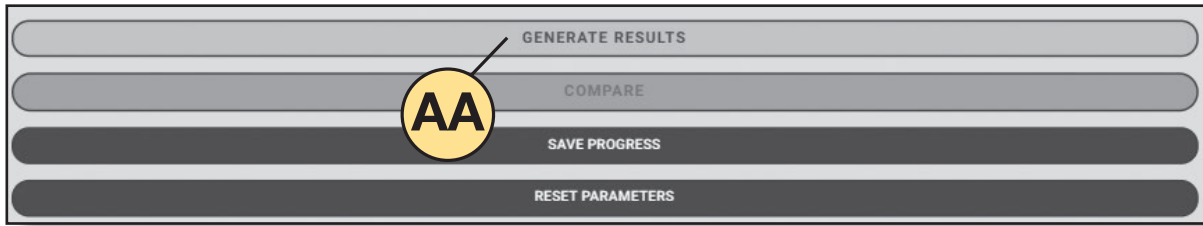

### Results

After returning to the top of the page, select “Generate Results” then “Compare”. The icons should appear yellow if all necessary criteria are met.

# Step 11

Compare all possible actuators sized for your application

**A**  
 Product Index,  
 Virtual Engineer,  
 Engineering Data

---

Product  
 Index

---

Virtual  
 Engineer

---

Engineering  
 Data

**Compare Linear Actuators**

CALCULATED VALUES

Stroke Length: 10 in

SELECT COLS **CC** Page size: 100 **BB** **DD** EXPORT

Product	Configure	RPT	Relative Price	Life (M cyl)
PSEF/032/254/M/N/*	CONFIGURE		1.00	7.5
PSEG/032/254/M/N/*	CONFIGURE		1.08	7.5
HBT4A/15/10/T/*/*	CONFIGURE		1.12	13.5
HBDT/15/10/T/*/*	CONFIGURE		1.12	13.5
PSEF/040/254/3/N/*	CONFIGURE		1.12	9.1
PSEF/040/254/M/N/*	CONFIGURE		1.12	12.6
HBC4A/20/10/T/*/*	CONFIGURE		1.13	13.5
HBCD/20/10/T/*/*	CONFIGURE		1.13	13.5
HBT4A/15/10/T/C1/*	CONFIGURE		1.16	13.5
HBT4A/15/10/T/C2/*	CONFIGURE		1.16	13.5
HBDT/15/10/T/C1/*	CONFIGURE		1.16	13.5
HBDT/15/10/T/C2/*	CONFIGURE		1.16	13.5
HBC4A/20/10/T/C1/*	CONFIGURE		1.17	13.5
HBC4A/20/10/T/C2/*	CONFIGURE		1.17	13.5
HBCD/20/10/T/C1/*	CONFIGURE		1.17	13.5
HBCD/20/10/T/C2/*	CONFIGURE		1.17	13.5
HBT4A/15/10/T/C/*	CONFIGURE		1.19	13.5
HBDT/15/10/T/C/*	CONFIGURE		1.19	13.5
PSEG/040/254/3/N/*	CONFIGURE		1.20	9.1
PSEG/040/254/M/N/*	CONFIGURE			
HBC4A/20/10/T/C/*	CONFIGURE			

Air Consumption  
 Bearing Type  
 Bore  
 End of Stroke Option  
 Force, Output Safety Factor-Extend  
 Force, Output Safety Factor-Retract  
 Force, Theoretical Output - Extend  
 Force, Theoretical Output - Retract  
 Guide Rod Diameter  
 Lead Time  
 Mount  
 Pressure, Maximum Operating (Rated)  
 Pressure, Minimum Operating (Breakaway)  
 Series  
 Standards  
 Temperature, Maximum Operating  
 Temperature, Minimum Operating  
 Valve Cv  
 Velocity, Maximum



**Sort**

Default is part numbers sorted low to high based on relative price. Relative price is cost of every part numbers divided by the least expensive.



**Configure**

Select to open configurator and finalize part number, view or download CAD, and request quote after logging in.



**Export**

Select to download Excel file containing the comparable actuators.



For inventory, lead times, and kit lookup, visit [www.pdnplu.com](http://www.pdnplu.com)

## Step 12a

Configure to retrieve part number and CAD files

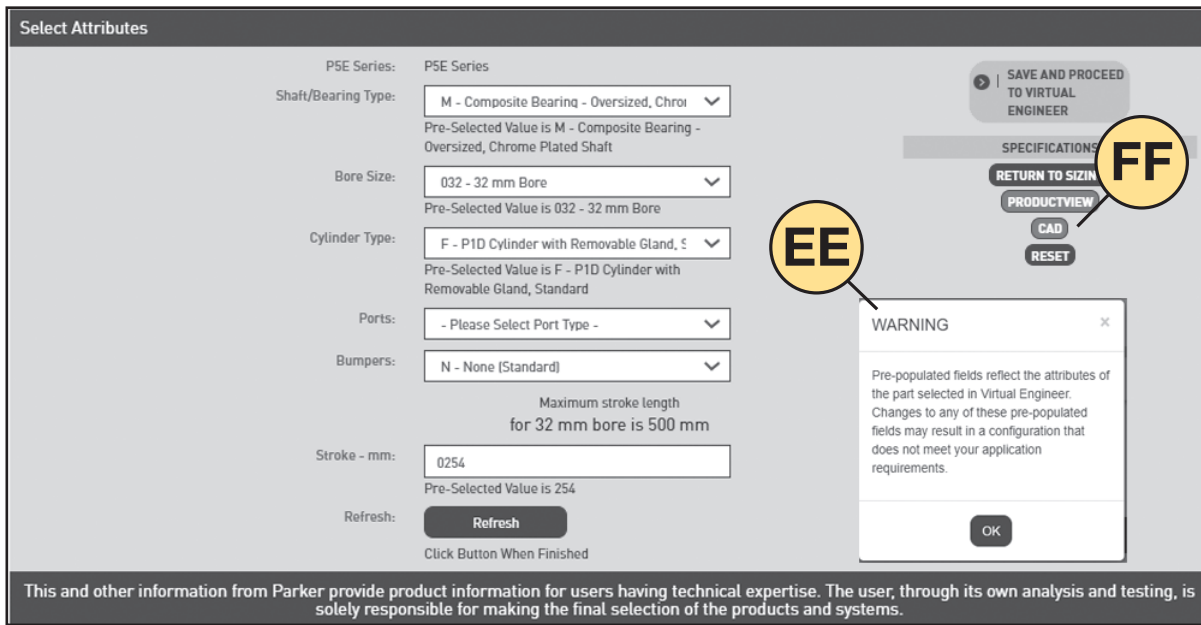

### Configurator

Once window appears, previously decided attributes will be populated (see warning). Select all other uncompleted fields.



### CAD Icon

Select to access CAD window.

## Step 12b

Configure to retrieve part number and CAD files

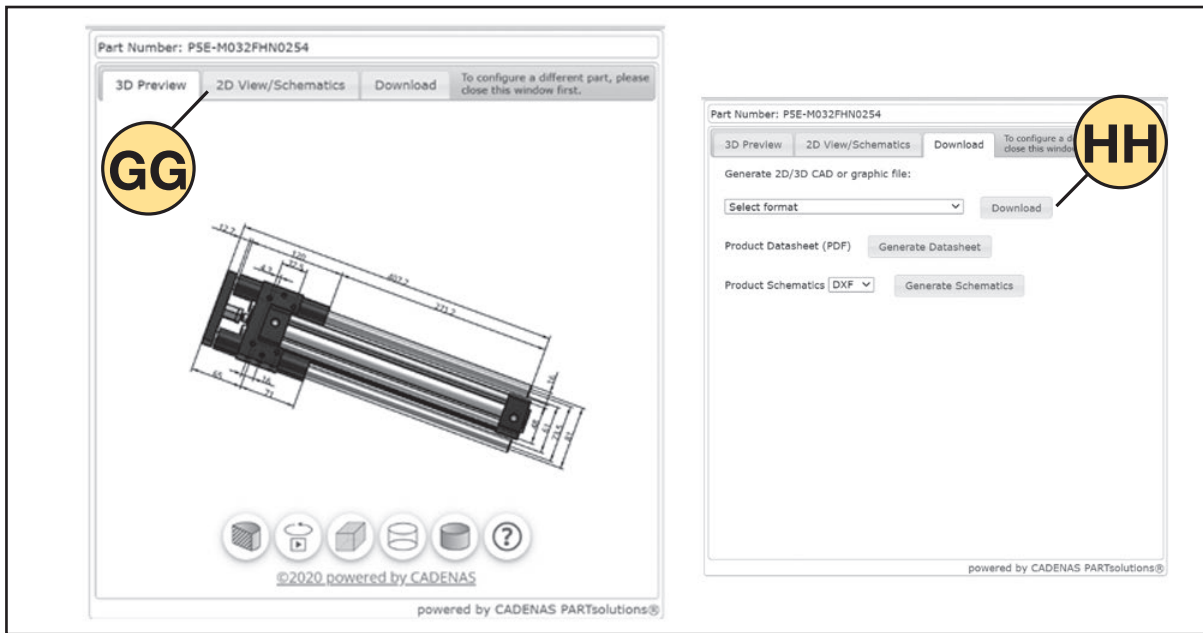

### 3D/2D View Options

View the configured CAD model's dimensions and schematic. Zoom in and out as desired.



### Download

Download numerous CAD graphic file options, the Product Datasheet, and Product Schematic.

**Step 13**

Save Project to Virtual Engineer Account

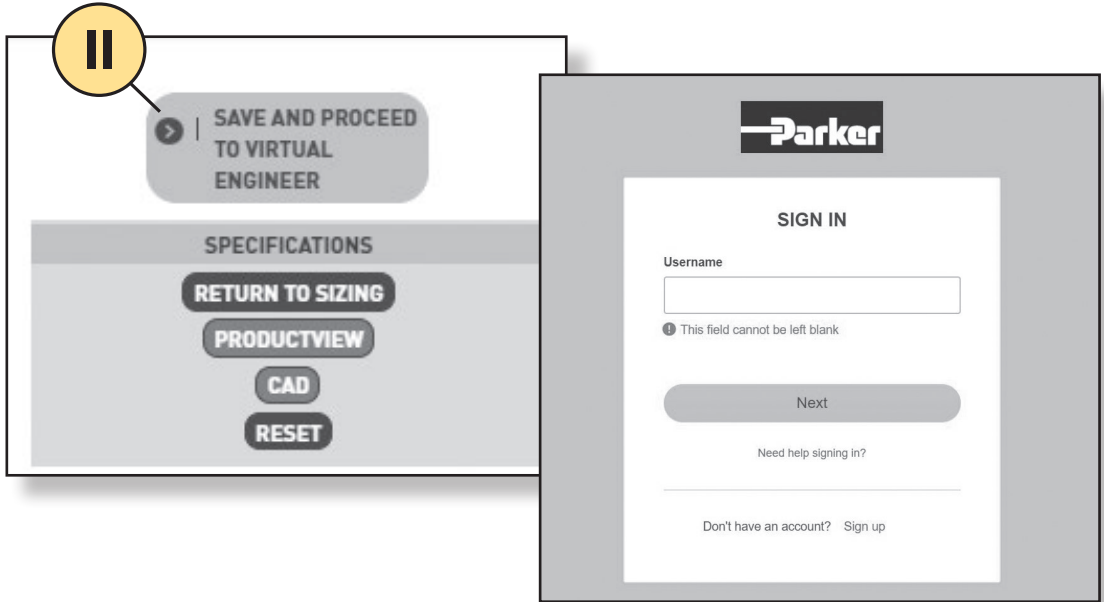

**Save and Proceed to Virtual Engineer Icon**

Access Virtual Engineer my projects page after signing in or creating an account.

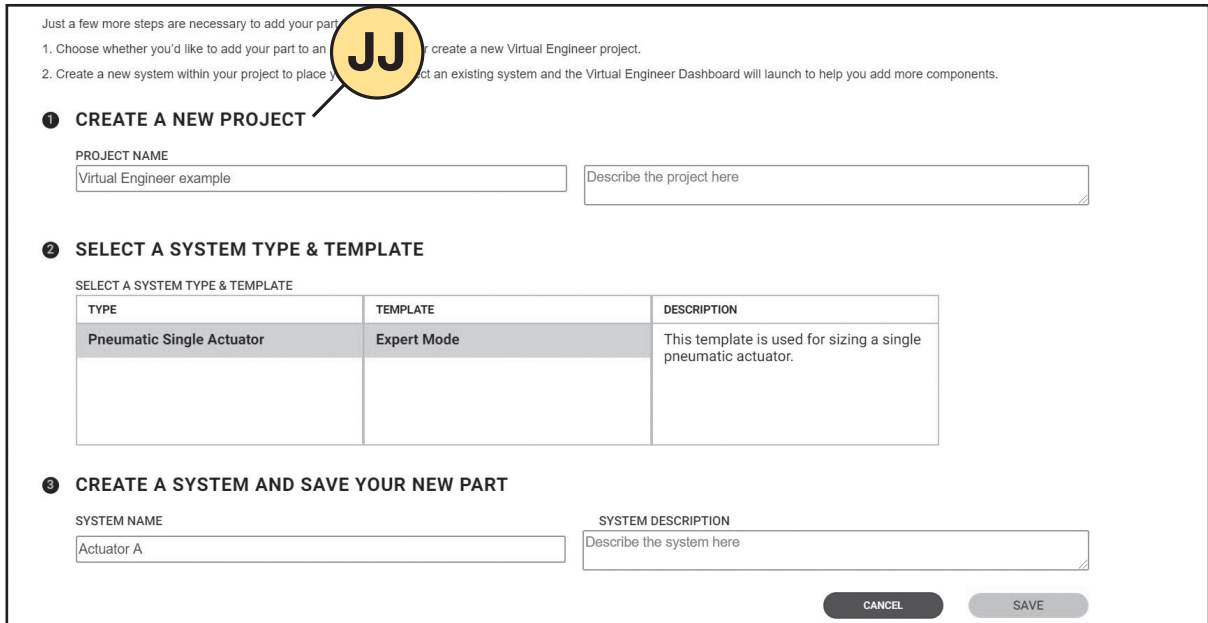

**Create New Project**

Create a new project to add configured actuator to or add to an existing project, then click save.



## Step 14a

Navigate My Projects Dashboard

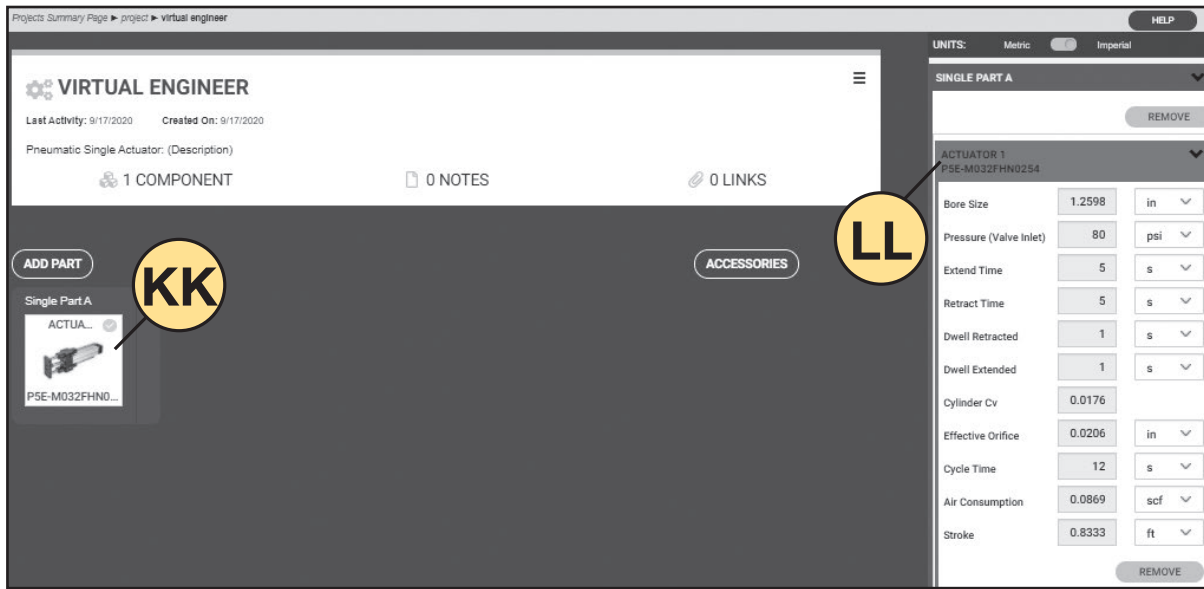

### Created Part Icon

Click the icon to view progress bar, edit or resume a project.  
The check mark at top left means actuator is fully configured.



### Part Parameter Summary

View summary of parameters chosen in Virtual Engineer.

## Step 14b

### Navigate My Projects Dashboard

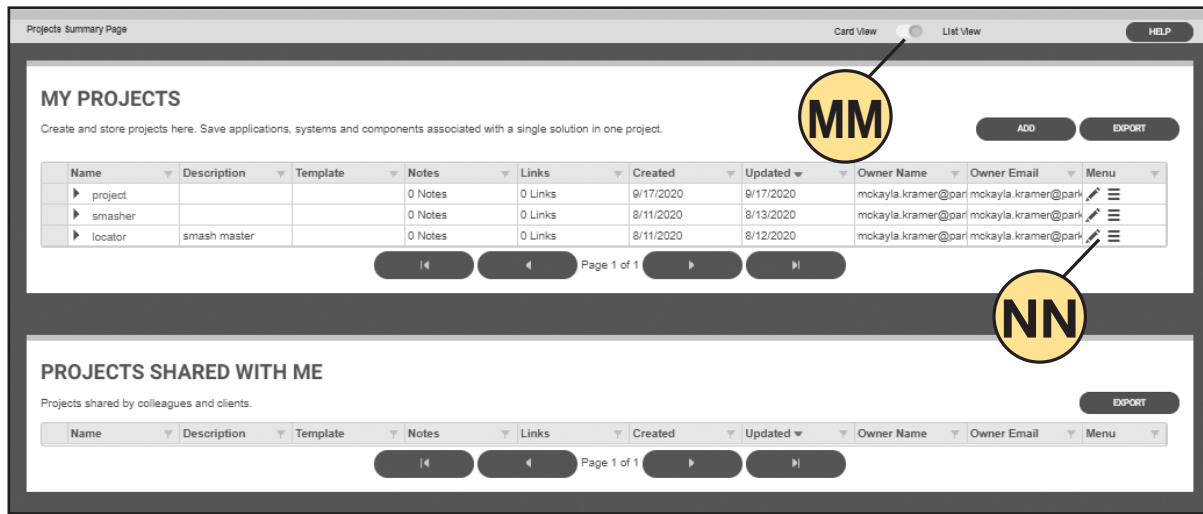

#### View Switch

The My Projects main page can be reorganized based on user preference. The List view is optimal for users with multiple projects.



#### Sharing Projects

Select three-lined icon to access options that allow for other users to edit or view your projects.

**A**

Product Index,  
Virtual Engineer,  
Engineering Data

Product  
Index

Virtual  
Engineer

Engineering  
Data

# The Parker 5-Year Extended Warranty

**P**arker Hannifin Corporation will extend its warranty on all pneumatic components to sixty (60) months providing they are correctly installed and protected by Parker pneumatic filters which are properly maintained. Components covered by this warranty include all cylinders, valves, and pneumatic automation components manufactured by Parker in any of our global facilities. This warranty covers our components anywhere in the world you may ship your equipment.

Parker's obligation under this warranty is limited to the replacement or repair of any failed components. The buyer understands that the seller will not be liable for any other costs or damages.

The buyers of quality Parker components and filters benefit by having ONE source for all pneumatic needs - **Parker.**



**Jennifer Parmentier**  
President  
Motion Systems Group



## Application Engineering Data

<b>Product Selection Guide</b>	A2-A3
<b>Engineering Data</b>	
Fluids, Temperature Range and Warranty	A4
Operating Principles and Construction	A5
Push and Pull Forces	A6
Mounting Information	
Straight Line Force Transfer (Group 1)	A7
Straight Line Force Transfer (Group 3)	A8
Pivot Force Transfer (Group 2)	A9
Accessories	
Removable Trunnion Pins	A10
Ports	A11
Stroke Data & Adjusters – Tie Rod Supports	A12
Stop Tubing & Mounting Classes	A13
Stroke Selection Chart	A14
Deceleration Forces and Air Requirements	A15
Cushion Rating and Air Requirements	A16
Air Requirements	A17-A18
NFPA Rod End Data & Piston Rods	A19
Modifications, Special Assemblies, Tandem	A20
Rotary Actuator	
Torque Requirements	A21-A23
Moments of Inertia	A24
Basic Equations	A25
Conversion Factors	A26

**A**

Product Index,  
Virtual Engineer,  
Engineering Data

Product  
Index

Virtual  
Engineer

Engineering  
Data



**A**  
**Product Index, Virtual Engineer, Engineering Data**  
**Product Index**  
**Virtual Engineer**  
**Engineering Data**

Catalog Section	Cylinder Series	Bore Size																										
		6mm	8mm	10mm	12mm	16mm	20mm	7/8"	1"	1-1/16"	1-1/8"	1-1/4"	1-1/2"	1-3/4"	2"	2-1/2"	3"	3-1/4"	3-5/8"	4"	4-1/2"	5"	6"	7"	8"	10"	12"	14"
<b>B - Tie Rod</b>	4MA											◆		◆	◆		◆		◆		◆	◆		◆				
	4MAJ Rodlock											◆		◆	◆		◆		◆		◆	◆		◆				
	ACVB Valve Option											◆		◆	◆		◆		◆		◆	Ⓢ		Ⓢ				
	P1D											■	■		■	■		■		■		■	■		■			
	P1F																											
<b>C - Round Body</b>	SR		◆		◆	◆	◆	◆		◆		◆	◆	◆	◆	◆	◆											
	SRM					◆	◆			◆		◆	◆	◆	◆	◆												
	SRD					◆	◆			◆		◆		◆														
	SRDM					◆	◆			◆		◆		◆														
	SRG						◆			◆		◆		◆	◆	◆												
	SRGM						◆			◆		◆		◆	◆	◆												
	SRX									◆		◆		◆	◆	◆	◆											
	P1A			■	■	■	■		■																			
	P									◆		◆		◆	◆	◆					◆							
<b>D - Compact</b>	LP					◆	◆			◆		◆		◆	◆	◆				◆								
	LPM					◆	◆			◆		◆		◆	◆	◆				◆								
<b>F - Rodless</b>	OSP-P			■		■			■		■	■		■	■			■										
	P1X					■	■		■		■	■		■	■													

- ◆ = Inch Bore Size
- = Metric Bore Size
- = Standard
- = Optional
- R = Required
- F = Fixed Cushions
- E = End of Stroke Only
- S = Special, Consult Factory



For inventory, lead times, and kit lookup, visit [www.pdnplu.com](http://www.pdnplu.com)

Construction	Cylinder Body Material	End Cap Material	# of Mountings	Pressure Range (PSI)	Single Acting	Double Acting	Adjustable Air Cushions	Flexible Porting Option	Piston Sensing Option	Cylinder Series	Catalog Section
NFPA	Aluminum	Aluminum	15	250	S	●	○		○	4MA	B - Tie Rod
NFPA	Aluminum	Aluminum	11	100	S	●	●		○	4MAJ Rodlock	
NFPA	N/A	N/A	17	145	N/A	N/A	N/A	N/A	N/A	ACVB Valve Option	
ISO/VDMA	Aluminum	Aluminum	10	145	S	●	○		●	P1D	
										P1F	
Non-repairable	Stainless Steel	Aluminum	28	250	●	●	○			SR	C - Round Body
Non-repairable	Stainless Steel	Aluminum	24	250	●	●	○		●	SRM	
Non-repairable	Stainless Steel	Acetal	2	100	S	●				SRD	
Non-repairable	Stainless Steel	Acetal	2	100	S	●			●	SRDM	
Non-repairable	Stainless Steel	Stainless Steel	2	250	N/A	●				SRG	
Non-repairable	Stainless Steel	Stainless Steel	2	250	N/A	●				SRGM	
Non-repairable	Stainless Steel	Aluminum	3	150		●			●	SRX	
Non-repairable	Stainless Steel	Aluminum	4	145	○	●	○		●	P1A	
Snap-Ring	Aluminum	Aluminum	4	150	○	●	○		○	P	
Tie Rod Compact	Aluminum	Aluminum	6	250	○	●				LP	
Tie Rod Compact	Aluminum	Aluminum	6	250	○	●			●	LPM	
Band-Type	Aluminum	Aluminum	11	120			●	●	●	OSP-P	F - Rodless
Band-Type Rodless	Aluminum	Aluminum	5	100	N/A	●	●	●	●	P1X	

- ◆ = Inch Bore Size
- = Metric Bore Size
- = Standard
- = Optional
- R = Required
- F = Fixed Cushions
- E = End of Stroke Only
- S = Special, Consult Factory

A

Product Index,  
Virtual Engineer,  
Engineering Data

---

Product Index

---

Virtual Engineer

---

Engineering Data



For inventory, lead times, and kit lookup, visit [www.pdnplu.com](http://www.pdnplu.com)

**A**  
Product Index,  
Virtual Engineer,  
Engineering Data

Product  
Index

Virtual  
Engineer

Engineering  
Data

**Operating Fluids and Temperature Range**

Fluidpower cylinders are designed for use with pressurized air, hydraulic oil and fire resistant fluids, in some cases special seals are required.

**Standard Seals (class 1)**

Class 1 seals are what is normally provided in a cylinder unless otherwise specified. They are intended for use with fluids such as: air, nitrogen, mineral base hydraulic oil or MIL-H-5606 within the temperature range of -10°F (-23°C) to 165°F (74°C). Generally they are nitrile except for piston rod seals in hydraulic cylinders. However the individual seals may be nitrile (Buna-N) enhanced polyurethane, polymyte, P.T.F.E. or filled P.T.F.E.

**Water Base Fluid Seals (class 2)**

Generally class 2 seals are intended for use with water base fluids within the temperature of -10°F (-23°C) to 165°F (74°C) except for High Water Content Fluids (H.W.C.F.) in which case Class 6 seals should be used. Typical water base fluids are: Water, Water-Glycol, Water-in Emulsion, Houghto-Safe 27, 620, 5040, Mobil Pyrogard D, Shell Iru 905, Ucon Hydrolube J-4. These seals are nitrile. Lipseal will have polymyte or P.T.F.E. back-up washer when required. O-rings will have nitrile back-up washers when required.

**Ethylene Propylene (E.P.R.) Seals (class 3)**

Class 3 seals are intended for use with some Phosphate Ester Fluids between the temperatures of -10°F (-23°C) to 130°F (54°C). Typical fluids compatible with E.P.R. seals are Skydrol 500 and 700. E.P.R. are Ethylene Propylene. Lipseals will have a P.T.F.E. back-up washer when required. O-rings will have EPR back-up washers when required. Note: E.P.R. seals are not compatible with mineral base hydraulic oil or greases. Even limited exposure to these fluids will cause severe swelling. P.T.F.E. back-up washer may not be suitable when used in a radiation environment.

**Low Temperature Nitrile Seals (class 4)**

Class 4 seals are intended for low temperature service with the same type of fluids as used with Class 1 seals within the temperature range of -50°F (-46°C) to 150°F (66°C). Lipseals will have leather, polymyte or P.T.F.E. back-up washers when required. O-rings will have nitrile back-up washers when required.

**Fluorocarbon Seals (class 5)**

Class 5 seals are intended for elevated temperature service or for some Phosphate Ester Fluids such as Houghto-Safe 1010, 1055, 1120; Fyrquel 150, 220, 300, 350; Mobile Pyrogard 42, 43, 53, and 55. Note: In addition, class 5 seals can be used with fluids listed below under standard service. However, they are not compatible with Phosphate Ester Fluids such as Skydrols. Class 5 seals can operate with a temperature range of -10°F (-23°C) to 250°F (121°C). Class 5 seals may be operated to 400°F (204°C) with limited service life, but please consult the pdnapps@parker.com for possible cylinder material changes. For temperatures above 250°F (120°C) the cylinder must be manufactured with non-studded piston rod and thread and a pinned piston to rod

connection. Class 5 Lipseals will have P.T.F.E. back-up washers when required. O-rings will have fluorocarbon back-up when required.

**Warning**

The piston rod stud and the piston rod to piston threaded connections are secured with an anaerobic adhesive which is temperature sensitive. Cylinders specified with Class 5 seals are assembled with anaerobic adhesive having a maximum temperature rating of 250°F (74°C). Cylinders specified with all other seal compounds are assembled with anaerobic adhesive having a maximum operating temperature rating 165°F (74°C). These temperature limitations are necessary to prevent the possible loosening of the threaded connections. Cylinders originally manufactured with class 1 seals (Nitrile) that will be exposed to ambient temperatures above 165°F (74°C) must be modified for higher temperature service. Contact the factory immediately and arrange for the piston to rod and the stud to piston rod connections to be properly re-assembled to withstand the higher temperature service.

**Lipseal Pistons**

Under most conditions lipseals provide the best all around service for pneumatic applications. Lipseals with a back-up washer are often used for hydraulic applications when virtually zero static leakage is required. Lipseals will function properly in these applications when used in conjunction with moderate hydraulic pressures.

**Water Service**

For pressures up to 400 PSIG, 4ML series cylinders can be modified to make them more suitable for use with water as the operating medium. Chrome plated 17-4 PH stainless steel piston rod is recommended to inhibit corrosion.

**Warranty**

Parker Hannifin will warrant cylinders modified for water or high water content fluid service to be free of defects in materials or workmanship, but cannot accept responsibility to premature failure due to excessive wear due to lack of lubricity or where failure is caused by corrosion, electrolysis or mineral deposits within the cylinder.

**Non-Lubricated Air Cylinders**

Cylinder series rated "Non-Lube" (such as 4MA, P1D, P1L, 2AN, etc.) are recommended for non-lubricated air service. These cylinders are originally lubricated at the factory and typically do not require any additional lubrication for most applications. Please note that the use of air-line oil lubricators will wash away the original grease lubricant, so it must be continued until the cylinder is serviced with the appropriate grease lubricant.

Many of the terms and drawings in this Engineering Section (such as mounting styles) utilize 2A or 4MA Series cylinders as examples. Although the terms, designs and drawings for other product series may be different, many basic principles apply. Please refer to these individual product sections in this catalog for additional information.

Class No.	Typical Fluids	Temperature Range
1 (Standard) (Nitrile Polyurethane)	Air, Nitrogen, Hydraulic Oil, Mil-H-5606 Oil	-10°F (-23°C) to 165°F (74°C)
2 Optional Water Base Fluid Seal	Water, Water-Glycol, Water-in-Oil Emulsion Houghto-Safe, 271, 620, 5040 Mobil Pyrogard D, Shell Iru 905 Ucon Hydrolube J-4	-10°F (-23°C) to 165°F (74°C)
3 Special (E.P.R.) (At extra cost) Note: (E.P.R.) seals are not compatible with Hydraulic Oil	Some Phosphate Ester Fluids Skydrol 500, 7000	-10°F (-23°C) to 130°F (54°C)
4 Special (Nitrile) (At extra cost)	Low Temperature Air or Hydraulic Oil	-50°F (-46°C) to 150°F (66°C)
5 Optional (At extra cost) (Fluorocarbon Seals)	High Temperature Houghto-Safe 1010, 1055, 1120 Fyrquel 150, 220, 300, 550 Mobil Pyrogard 42,43,53,55	See above paragraph on fluorocarbon seals for recommended temperature range.

Note: Fluorocarbon seals are not suitable for use with Skydrol fluid, but can be used with hydraulic oil if desired



For inventory, lead times, and kit lookup, visit [www.pdnplu.com](http://www.pdnplu.com)



## Fundamental Cylinders

### Standard Double-Acting Cylinders

Power stroke is in both directions and is used in the majority of applications.

### Single-Acting Cylinders

When thrust is needed in only one direction, a single-acting cylinder may be used. The inactive end is vented to atmosphere through a breather/filter for pneumatic applications, or vented to reservoir below the oil level in hydraulic application.

### Double-Rod Cylinders

Used when equal displacement is needed on both sides of the piston, or when it is mechanically advantageous to couple a load to each end. The extra end can be used to mount cams for operating limit switches, etc.

### Spring Return, Single-Acting Cylinders

Usually limited to very small, short stroke cylinders used for holding and clamping. The length needed to contain the return spring makes them undesirable when a long stroke is needed.

### Ram Type, Single-Acting Cylinders

Containing only one fluid chamber, this type of cylinder is usually mounted vertically. The weight of the load retracts the cylinder. They are sometimes know as “displacement cylinders”, and are practical for long strokes.

### Telescoping Cylinders

Available with up to 4 or 5 sleeves; collapsed length is shorter than standard cylinders. Available either single or double-acting, they are relatively expensive compared to standard cylinders.

### Tandem Cylinders

A tandem cylinder is made up of two cylinders mounted in line with pistons connected by a common piston rod and rod seals installed between the cylinders to permit double acting operation of each. Tandem cylinders allow increased output force when mounting width or height are restricted.

### Duplex Cylinders

A duplex cylinder is made up of two cylinders mounted in line with pistons not connected and with rod seals installed between the cylinders to permit double acting operation of each. Cylinders may be mounted with piston rod to piston (as shown) or back to back and are generally used to provide three position operation.

Illustration B29

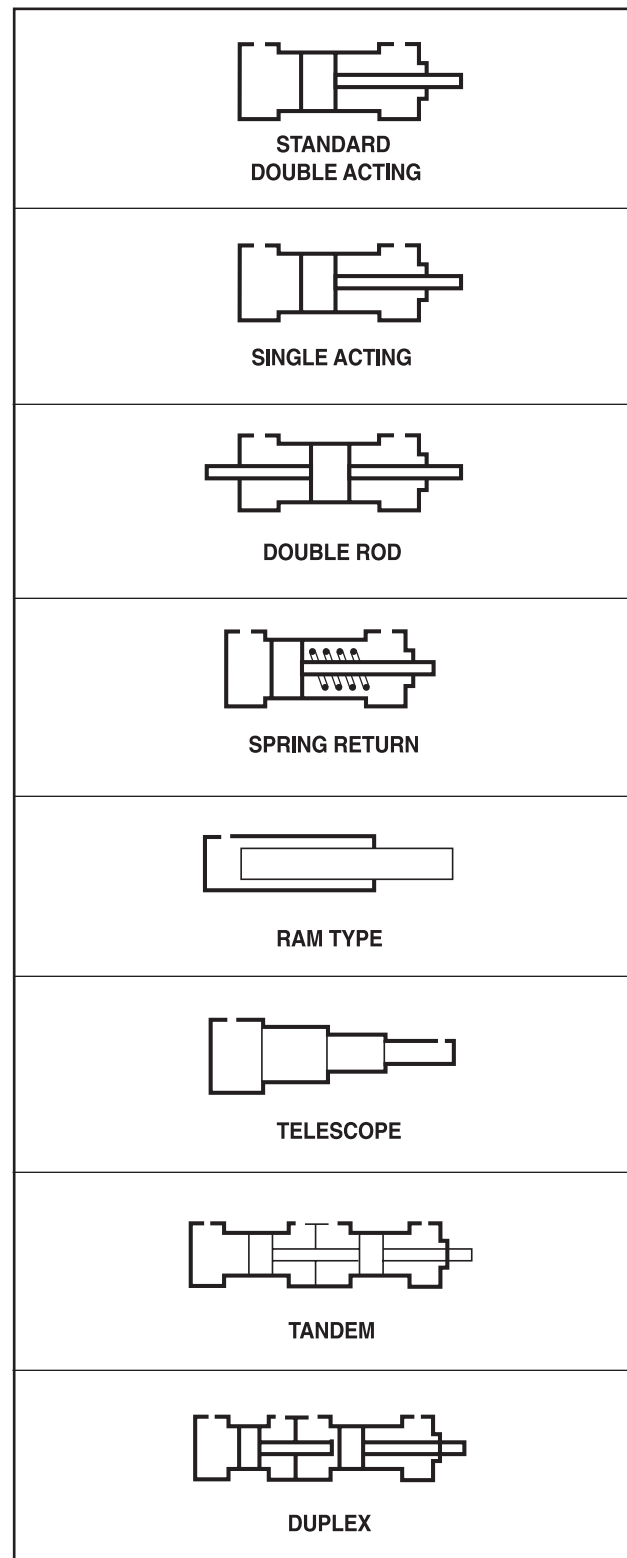

**A**

Product Index,  
Virtual Engineer,  
Engineering Data

Product  
Index

Virtual  
Engineer

Engineering  
Data

**Calculation of Cylinder Forces – Inch Based Product**

**Theoretical Push and Pull Forces for Pneumatic Cylinders**

**A**

Product Index,  
 Virtual Engineer,  
 Engineering Data

**Push Force and Displacement**

Cylinder Bore Size (inch)	Piston Area (in <sup>2</sup> )	Cylinder Push Stroke Force in Pounds at Various Pressures (PSI)						Cu. Ft. Free Air at 80 lbs. Pressure, Required to Move Max. Load 1 Inch	Displacement Per Inch of Stroke (ft <sup>3</sup> )
		25	50	65	80	100	250		
1-1/8	0.994	25	50	65	80	99	249	0.00371	0.0005751
1-1/2	1.767	44	88	115	142	177	443	0.00659	0.0010225
2	3.14	79	157	204	251	314	785	0.01171	0.0018171
2-1/2	4.91	123	245	319	393	491	1228	0.01830	0.0028414
3-1/4	8.30	208	415	540	664	830	2075	0.03093	0.0048032
4	12.57	314	628	817	1006	1257	3143	0.04685	0.0072743
5	19.64	491	982	1277	1571	1964	4910	0.07320	0.0113657
6	28.27	707	1414	1838	2262	2827	7068	0.10541	0.0163599
7	38.49	962	1924	2502	3079	3849	9623	0.14347	0.0222743
8	50.27	1257	2513	3268	4022	5027	12568	0.18740	0.0290914

Product Index

Virtual Engineer

Engineering Data

**Deductions for Pull Force and Displacement**

Piston Rod Dia. (inch)	Piston Rod Area (in <sup>2</sup> )	Piston Rod Diameter Force In Pounds At Various Pressures (PSI)						Cu. Ft. Free Air at 80 lbs. Pressure, Required to Move Max. Load 1 Inch	Displacement Per Inch of Stroke (ft <sup>3</sup> )
		25	50	65	80	100	250		
3/8	0.110	3	6	7	9	11	28	0.00041	0.0000636
1/2	0.196	5	10	13	16	20	49	0.00073	0.0001134
5/8	0.307	8	15	20	25	31	77	0.00114	0.0001776
1	0.785	20	39	51	65	79	196	0.00293	0.0004542
1-3/8	1.49	37	75	97	119	149	373	0.00554	0.0008622
1-3/4	2.41	60	121	157	193	241	603	0.00897	0.0013946

**Piston Rod Diameter Force In Pounds At Various Pressures (PSI)**

To determine Cylinder Pull Force or Displacement, deduct the following Force or Displacement corresponding to Rod Size, from selected Push Stroke Force or Displacement corresponding to Bore Size in table above.

**General Formula**

The cylinder output forces are derived from the formula:

- Where
- F = Force in pounds.
  - P = Pressure at the cylinder in pounds per square inch, gauge.
  - A = Effective area of cylinder piston in square inches.

$$F = P \times A$$

Free Air refers to normal atmospheric conditions of the air at sea level (14.7 PSI). Use above cu. ft. free air required data to compute CFM required from a compressor at 80 PSI. Cu. ft. of free air required at other pressures can be calculated using formula below.

$$V_1 = \frac{(P_2 + 14.7) V_2}{14.7}$$

- Where
- V<sub>1</sub> = Free air consumption per inch of stroke (cubic feet).
  - V<sub>2</sub> = Cubic feet displaced per inch of stroke.
  - P<sub>2</sub> = Gauge pressure required to move maximum load.



For inventory, lead times, and kit lookup, visit [www.pdnplu.com](http://www.pdnplu.com)

## Mounting Information

Single rod type, fluid power cylinders are commonly available in 20 standard mounting styles ranging from head or cap end mounts to intermediate mounts. Many mounting styles are also available in double rod type cylinders. Refer to NFPA Std. B93.15-1981 or Parker air or hydraulic cylinder catalogs for detailed description.

Standard mounting styles for fluid power cylinders fall into three basic groups. The groups can be described as follows.

**Group 1** – Straight line force transfer with fixed mounts which absorb force on cylinder centerline.

**Group 3** – Straight line force transfer with fixed mounts which do not absorb force on cylinder centerline.

**Group 2** – Pivot force transfer with pivot mounts which absorb force on cylinder centerline and permit cylinder to change alignment in one plane.

Cylinder mounting directly affects the maximum pressure at which the fluid power cylinder can be used, and proper selection of mounting style will have a bearing on cylinder operation and service life. Whether the cylinder is used in thrust or tension, its stroke length, piston rod diameter and the method of connection to load also must be considered when selecting a mounting style.

Many pneumatic cylinders are offered for use with air pressure up to 250 PSI. The industrial tie rod types, known as NFPA cylinders, with square heads and caps, plus mountings lend themselves to standardized mounts which are similar in appearance for air cylinders.

### Straight Line Force Transfer (Group 1)

Cylinders with fixed mounts (Group 1) which absorb the force on centerline are considered the best for straight line force transfer. Tie rods extended, flange or centerline lug mounts are symmetrical and allow the thrust or tension forces of the piston rod to be distributed uniformly about the cylinder centerline. Mounting bolts are subjected to simple tension or simple shear without compound forces, and when properly installed damaging cylinder bearing sideloading is kept to a minimum.

**Tie Rods Extended** are considered to be of the centerline mount type. The cylinder tie rods are designed to withstand maximum rated internal pressure and can be extended and used to mount the cylinder at cap or head end. This often overlooked mounting will securely support the cylinder when bolted to the panel or machine member to which the cylinder is mounted. The torque value for the mounting nuts should be the same as the tie rod nut torque recommended by the cylinder manufacturer. Cylinders are available with tie rod extended both ends. In such applications one end is used for mounting and the opposite end to support the cylinder or to attach other machine components.

Tie rod mount cylinders may be used to provide thrust or tension forces at full rated pressures.

Tie rods extended head end (Style TB), cap end (Style TC) or extended both ends (Style TD) are readily available and fully dimensioned in Parker cylinder product catalogs.

**Flange Mount** cylinders are also considered to be centerline mount type and thus are among the best mounts for use on straight line force transfer applications. The machine designer has a choice of mounting styles at each end, such as head rectangular flange (Style J), head square flange (Style JB), cap rectangular flange (Style H), and cap square flange (Style HB). Selection of a flange mounting style depends, in part, upon whether the major force applied to the load will result in compression (push) or tension (pull) stresses of the cylinder piston rod. Cap end mounting styles are recommended for thrust loads (push), while head end mounting styles are recommended where the major load puts the piston rod in tension (pull).

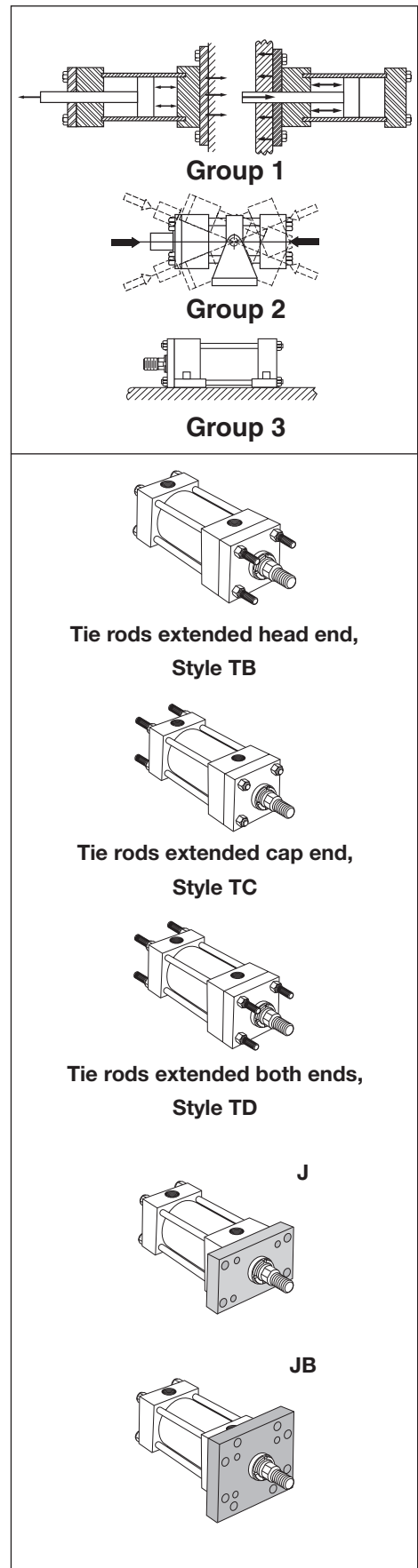

A

Product Index,  
Virtual Engineer,  
Engineering Data

Product  
Index

Virtual  
Engineer

Engineering  
Data

Mounting Information

A

Product Index,  
Virtual Engineer,  
Engineering Data

Product  
Index

Virtual  
Engineer

Engineering  
Data

Flange mounts are best used when end face is mounted against the machine support member. (Fig. 1) This is especially true where head rectangular flange type (Style J) is used with major load in tension. In this mode, the flange is not subjected to flexure or bending stresses, nor are the mounting bolts stressed to unusually high levels. The use of head rectangular flange (Style J) mount with major load in compression (see Fig. 2) is not recommended except on reduced pressure systems. The use of Style J mount in compression subjects the flange to bending and the mounting bolts to tension stresses, which could result in early fatigue failure. For applications where push forces require full rated system pressure, head square flange (Style JB) mounts are recommended.

Cap flange mounts are also best used when end face is mounted against the machine support member. The use of cap rectangular flange mount, Style H, is not recommended on applications where the major load is in tension (pull) except at reduced pressure.

For applications where pull forces involved require full rated system pressure, cap square flange, Style HB mounts are recommended.

**Straight Line Force Transfer (Group 3)**

**Side Mount** cylinders are considered to be fixed mounts which do not absorb force on their centerline. Cylinders of this group have mounting lugs connected to the ends, and one style has side tapped holes for flush mounting. The plane of their mounting surfaces is not through the centerline of the cylinder, and for this reason side mounted cylinders produce a turning moment as the cylinder applies force to the load. (Fig. 4) This turning moment tends to rotate the cylinder about its mounting bolts. If the cylinder is not well secured to the machine member on which it is mounted or the load is not well-guided, this turning moment results in side load applied to rod gland and piston bearings. To avoid this problem, side mount cylinders should be specified with a stroke length at least equal to the bore size.

Shorter stroke, large bore cylinders tend to sway on their mountings when subjected to heavy loads, especially side end lug or side and angle mounts. (Fig. 5)

Side mount cylinders are available in several mounting styles, such as side lug (Style C), Side tapped (Style F or TEF), side end lug (Style G) and side end angle (Style CB). Of these, the side lug mount is the most popular and reliable, since the mounting lugs are part of the head and cap (4MA and 2A).

Side tapped mount is the choice when cylinders must be mounted side by side at minimum center-to-center distance. Another narrow side mount style is the side end lug mount which has lugs threaded to the tie rods. Thus the end lugs serve a dual function of holding the cylinder together and act as a means of mounting. This mounting style should be used only on medium- to light-duty applications, because the end lugs are subjected to compound stresses which could result in early failure.

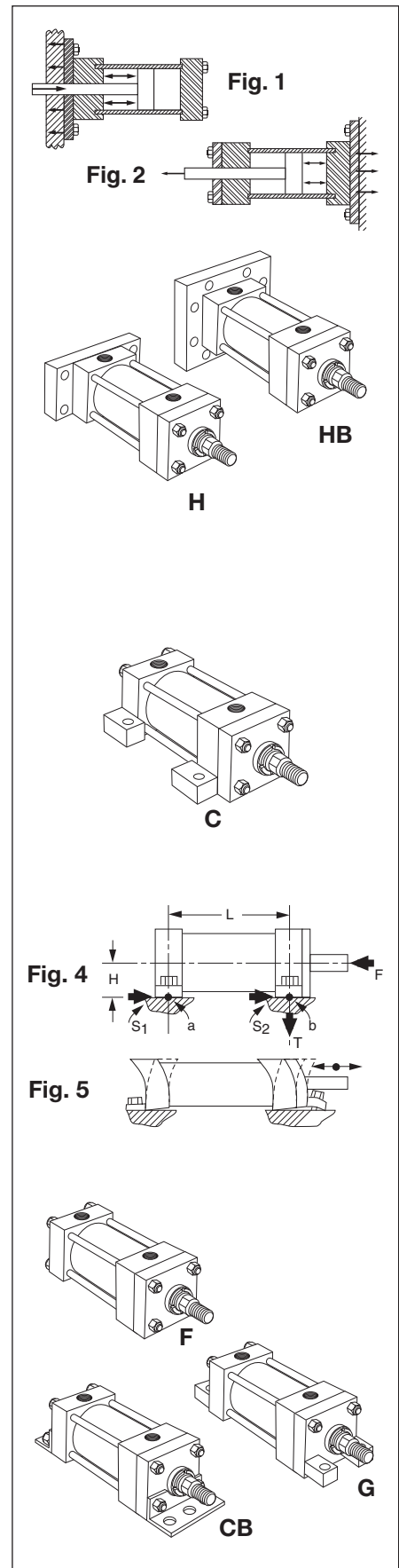

The side end angle mount is also a narrow mount type, but is the weakest of the side mount styles. Its use should be limited to a maximum pressure of 150 PSI and minimum stroke length of two times the bore size. For pressure rating of longer strokes, consult the cylinder manufacturer.

Consideration should also be given to design of the machine frame used to support cylinders non-centerline mount, since stronger members are often required to resist bending moments. (See Fig. 6)

Side mount cylinders depend wholly on the friction of their mounting surfaces in contact with the machine member to absorb the force produced. Thus the torque applied to the mounting bolts is an important consideration. Since the mounting bolts are the same diameter as the tie rods for a given cylinder, it is recommended that the torque applied to the mounting bolts be the same as the tie rod torque recommended by the cylinder manufacturer for the given bore size.

For heavy loads or high shock conditions, side mounted cylinders should be held in place to prevent shifting by keying or pinning. A shear key, consisting of a plate extending from side of cylinder, can be supplied on most cylinders. (Fig. 7) This method may be used where a keyway can be milled into a machine member. It serves to take up shear loads and also provides accurate alignment of the cylinder.

Side lug mounts are designed so as to allow dowel pins to be used to pin the cylinder to the machine member. Pins, when used, are installed on both sides of the cylinder but not at both ends. (See Fig. 8)

The use of a separate shear key is fairly common. It should be placed at the proper end of the cylinder to absorb the major load. (see Fig. 9)

Side mount cylinders should not be pinned or keyed at both ends. Changes in temperature and pressure under normal operating conditions cause the cylinder to increase (or decrease) in length from its installed length and therefore must be free to expand and contract. If pinned or keyed at both ends, the advantages of cylinder elasticity in absorbing high shock loads will be lost. (Fig. 10)

If high shock loads are the major consideration, the cylinder should be mounted and pins or shear key so located as to take full advantage of the cylinder's inherent elasticity. For major shock load in tension, locate key at rear face of head or pin the head in place. For major shock load in thrust, pin cap in place or locate key at front face of cap.

**Pivot Force Transfer (Group 2)**

Cylinders with pivot mounts which absorb force on centerline should be used on applications where the machine member to be moved travels in a curved path. There are two basic ways to mount a cylinder so that it will pivot during the work cycle: clevis or trunnion mounts, with variations of each. Pivot mount cylinders are available in cap fixed clevis (Style BB), cap detachable clevis (Style BC), cap spherical bearing (Style SB), head trunnion (Style D), cap trunnion (Style DB), and intermediate fixed trunnion (Style DD).

Pivot mount cylinders can be used on tension (pull) or thrust (push) applications at full rated pressure, except long stroke thrust cylinders are limited by piston rod column strength. See Piston Rod Selection Chart on page A14.

Clevis or single ear mounts are usually an integral part of the cylinder cap (though one style is detachable) and provide a single pivot point for mounting the cylinder. A pivot pin of proper length and of sufficient diameter to withstand the maximum shear load developed by the cylinder at rated operating pressure is included as a part of the clevis mount style. The fixed clevis mount, Style BB, is the most popular of the pivot force transfer types and is used on applications where the piston rod end travels in a curved path in one plane. It can be used vertically or horizontally or any angle in between. On long stroke push applications it may be necessary to use a larger diameter piston rod to prevent buckling or stop tube to minimize side loading due to "jackknife" action of cylinder in extended position. Fixed clevis mount cylinders will not function well if the curved path of piston rod travel is other than one plane. Such an application results in misalignment and causes the gland and piston bearing surfaces to be subjected to unnecessary side loading. For applications where the piston rod will travel in a path not more than 3° either side of the true plane motion, a cap spherical bearing mount is recommended. A spherical bearing rod eye should be used at rod end. Most spherical bearing mounts have limited pressure ratings. Consult cylinder manufacturer's product catalog.

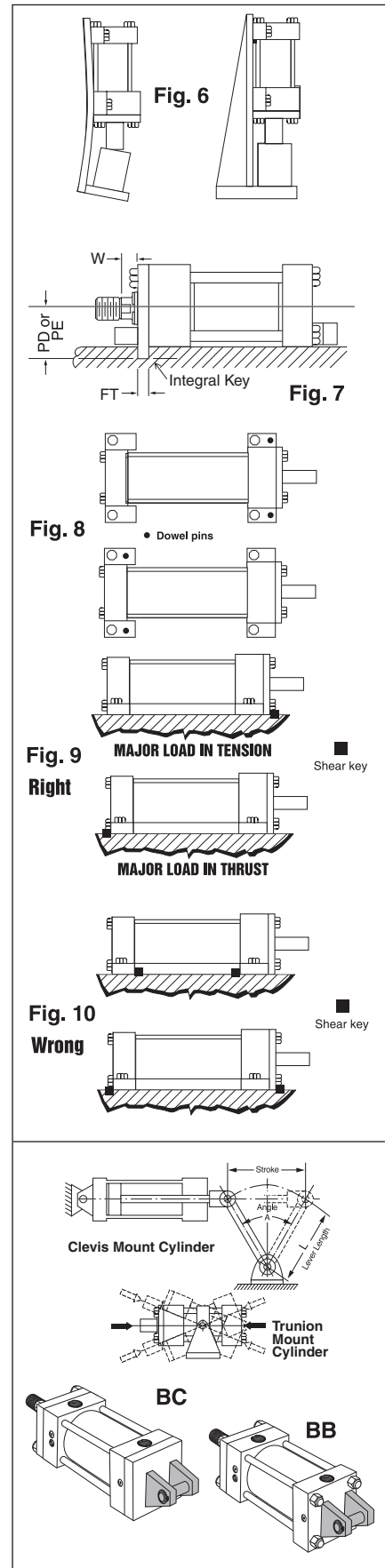

<b>A</b>
Product Index, Virtual Engineer, Engineering Data
Product Index
Virtual Engineer
Engineering Data



**A**  
 Product Index,  
 Virtual Engineer,  
 Engineering Data  
 Product  
 Index  
 Virtual  
 Engineer  
 Engineering  
 Data

Cap detachable clevis mounts are usually used for air service. Cap detachable clevis mounts are longer, centerline of pivot pin to shoulder of piston rod, than fixed clevis mount in any given bore size. They are most often specified to avoid port relocation charges. Application parameters are the same as described for fixed clevis mounting.

Trunnion mount cylinders are a second type of pivot mounts used on applications where the piston rod travels in a curved path in one plane. Three styles are available – head trunnion (Style D), cap trunnion (Style DB) and intermediate fixed trunnion (Style DD). Trunnion pins are designed for shear loads only and should not be subjected to bending stresses. Pillow blocks, rigidly mounted with bearings at least as long as the trunnion pins, should be used to minimize bending stresses. The support bearings should be mounted as close to the head, cap or intermediate trunnion shoulder faces as possible.

Cap end trunnion mounts are used on cylinder applications similar to fixed clevis mounts, and the same application data applies.

Head trunnion mount cylinders can usually be specified with smaller diameter piston rods than cylinders with pivot point at cap end or at an intermediate position. This is evident in data shown in piston rod selection chart on page A14. On head end trunnion mount, long stroke, cylinder applications consideration should be given to the overhanging weight at cap end of cylinder. To keep trunnion bearing loading within limits, stroke lengths should be not more than 5 times the bore size. If cylinder stroke is greater than 5 times the bore size and piston speed exceeds 35 ft/minute, consult factory.

Intermediate fixed trunnion mount is the best of the trunnion mount types. The trunnion can be located so as to balance the weight of the cylinder, or it can be located at any point between the head or cap to suit the application. It is of fixed design, and the location of the trunnion must be specified (X1 dimension) at time of order. The location cannot be easily changed once manufactured.

Thrust exerted by a pivot transfer cylinder working at an angle is proportional to the angle of the lever arm which it operates. In Fig. 12 that vector force, T, which is at right angle to the lever axis, is effective for turning the lever. The value of T varies with the acute angle A between cylinder centerline and lever axes. To calculate effective thrust T, multiply cylinder thrust by the power factor shown in table below.

**Accessories**

Rod clevises or rod knuckles are available for use with either fixed or pivot mount cylinders. Such accessories are usually specified with pivot mount cylinders and are used with pivot pin centerline in same axis as pivot pin centerline on cylinder. Pivot pins for accessories must be ordered separately.

Pin size of rod clevis or rod knuckle should be at least equal in diameter to the pin diameter of the cap fixed clevis pin for the cylinder bore size specified. Larger accessories are more costly and usually result in a mismatch of pin diameters, especially when used with oversize piston rods.

**Removable Trunnion Pins**

Removable trunnion pins are a convenience when machine structures or confined space prohibit the use of separate pillow blocks situated close to the cylinder sides.

**Spherical Bearing Mount**

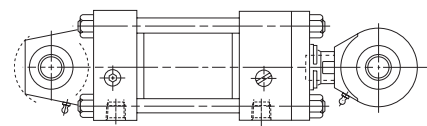

**Fig. 11**

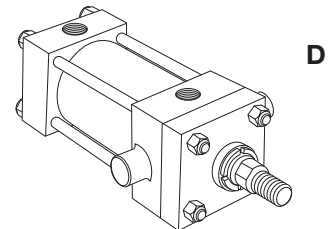

**D**

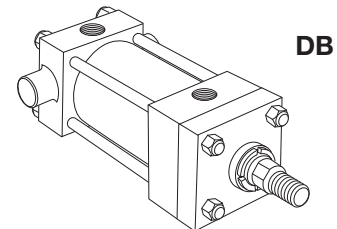

**DB**

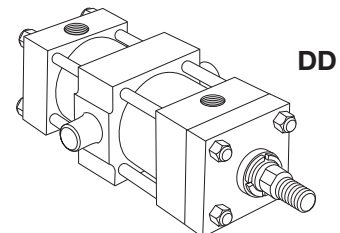

**DD**

**Clevis Mount Cylinder**

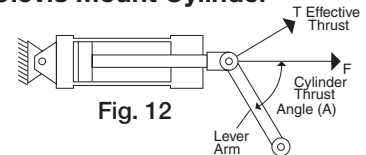

**Fig. 12**

**Power Factor Table**

Angle A Degrees	Pwr. Factor (SIN A)	Angle A Degrees	Pwr. Factor (SIN A)
5	0.087	50	0.766
10	0.174	55	0.819
15	0.259	60	0.867
20	0.342	65	0.906
25	0.423	70	0.940
30	0.500	75	0.966
35	0.573	80	0.985
40	0.643	85	0.996
45	0.707	90	1.000



For inventory, lead times, and kit lookup, visit [www.pdnplu.com](http://www.pdnplu.com)

## Ports

### Ports

Parker hydraulic and pneumatic cylinders can be supplied with S.A.E. straight O-ring ports or N.P.T.F. pipe thread ports. For the type of port recommended and port size, see respective product catalogs. If specified on your order, extra ports can be provided on the sides of heads or caps that are not occupied by mountings or cushion valve on all cylinders.

Standard port location is position 1 as shown on line drawings in product catalog and Figure 1 below. Cushion adjustment needle valves are at positions 2 and 4 (or 3), depending on mounting style. Heads or caps which do not have an integral mounting can be rotated and assembled with ports at 90° or 180° from standard position. Mounting styles on which head or cap can be rotated at no extra charge are shown in Table A below. To order, specify by position number. In such assemblies the cushion adjustment needle valves rotate accordingly, since their relationship with port position does not change.

Figure 1

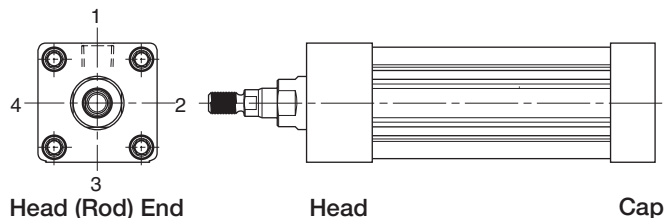

Table A

Mounting Style	Head End	Cap End
T, TB, TC, TD, H, HB, J, JB, DD	1, 2, 3 or 4	1, 2, 3 or 4
BB, DB	1, 2, 3 or 4	1 or 3
D	1 or 3	1, 2, 3 or 4
C, F	1	1

### Straight Thread Ports

The S.A.E. straight thread O-ring port is recommended for hydraulic applications. Parker will furnish this port configuration at positions shown in Table A above. This port can also be provided at positions other than those shown in Table A at an extra charge. Size number, tube O.D. and port thread size for S.A.E. ports are listed in Table C. S.A.E. ports are available at extra cost.

Table C

#### S.A.E. Straight Thread "O" Ring Ports

Size No.	Tube O.D. (in.)	Thread Size	Size No.	Tube O.D. (in.)	Thread Size
2	1/8"	5/16 - 24	12	3/4"	1-1/16 - 12
3	3/16"	3/8 - 24	—	—	—
4	1/4"	7/16 - 20	16	1"	1-5/16 - 12
5	5/16"	1/2 - 20	20	1-1/4"	1-5/8 - 12
6	3/8"	9/16 - 18	24	1-1/2"	1-7/8 - 12
8	1/2"	3/4 - 16	32	2"	2-1/2 - 12
10	5/8"	7/8 - 14	—	—	—

**Note:** For the pressure ratings of individual connectors, contact your connector supplier.

## Pneumatic Actuator Products Application Engineering Data

### Cylinder Port Options

- Option "T" SAE Straight Thread O-Ring Port. Recommended for most hydraulic applications.
- Option "U" Conventional NPTF Ports (Dry-Seal Pipe Threads). Recommended for pneumatic applications only.
- Option "R" BSPP Port (British Parallel Thread). ISO 228 port commonly used in Europe.
- Option "P" SAE Flange Ports Code 61. Recommended for hydraulic applications requiring larger port sizes.
- Option "B" BSPT (British Tapered Thread).
- Option "G" Metric Straight Thread Port similar to Option "R" with metric thread. Popular in some European applications.
- Option "Y" ISO-6149-1 Metric Straight Thread Port. Recommended for all hydraulic applications designed per ISO standards.

Ports can be supplied at positions other than those shown in Table A at an extra charge. To order, specify port position as shown in Figure 1.

### International Ports

Other port configurations to meet international requirements are available at extra cost. Parker cylinders can be supplied, on request, with British standard taper port (BSPT). Such port has a taper of 1 in 16 measured on the diameter (1/16" per inch). The thread form is Whitworth System, and size and number of threads per inch are as follows:

Table D

#### British Standard Pipe Threads

Nominal Pipe Size	No Threads Per Inch	Pipe O.D.
1/8	28	0.383
1/4	19	0.518
3/8	19	0.656
1/2	14	0.825
3/4	14	1.041
1	11	1.309
1-1/4	11	1.650
1-1/2	11	1.882
2	11	2.347

British standard parallel internal threads are designated as BSP and have the same thread form and number of threads per inch as the BSPT type and can be supplied, on request, at extra cost. Unless otherwise specified, the BSP or BSPT port size supplied will be the same nominal pipe size as the N.P.T.F. port for a given bore size cylinder.

Metric ports options G or Y can also be supplied to order at extra cost.

**A**  
Product Index,  
Virtual Engineer,  
Engineering Data

Product  
Index

Virtual  
Engineer

Engineering  
Data



For inventory, lead times, and kit lookup, visit [www.pdnplu.com](http://www.pdnplu.com)

**Stroke Data**

Parker cylinders are available in any practical stroke length. The following information should prove helpful to you in selecting the proper stroke for your cylinder application.

**Stroke Tolerances** – Stroke length tolerances are required due to build-up of tolerances of piston, head, cap and cylinder body. Standard production stroke tolerances run +1/32" to -1/64" up to 20" stroke, +1/32" to -.020" for 21" to 60" stroke and +1/32" to -1/32" for greater than 60" stroke. For closer tolerances on stroke length, it is necessary to specify the required tolerance plus the operating pressure and temperature at which the cylinder will operate. Stroke tolerances smaller than .015" are not generally practical due to elasticity of cylinders. If machine design requires such close tolerances, use of a stroke adjuster (below) may achieve the desired result.

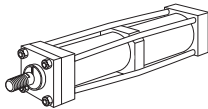
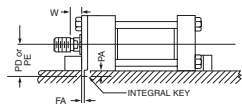

**Tie Rod Supports**

**Rigidity of Envelope** – The pre-stressed tie rod construction of Parker cylinders has advantages in rigidity within the limits of the cylinder tube to resist buckling. For long stroke cylinders within practical limits, Parker provides exclusive TIE ROD SUPPORTS (see table below) which move the tie rod centerlines radially outward.

Standard tie rod supports are kept within the envelope dimensions of the head and cap, and generally do not interfere with mounting a long cylinder.

Number of Supports Required	Stroke (inches)													
	Bore	36	48	60	72	84	96	108	120	132	144	156	168	
1	—	1	1	1	2	Consult Factory								
1-1/2	—	—	1	1	1	2	2	2	3	3	3	3	4	
2	—	—	—	1	1	1	1	2	2	2	2	2	3	
2-1/2	—	—	—	—	—	1	1	1	1	1	1	2	2	
3-1/4	—	—	—	—	—	—	—	1	1	1	1	1	1	
4	—	—	—	—	—	—	—	—	—	—	1	1	1	

Note: 5" through 14" bore sizes — no supports required.

**Stroke Adjusters (only with metallic piston)**

**Stroke Adjusters** – For the requirement where adjusting the stroke is specified. Parker has several designs to offer, one of which is illustrated below. This is suitable for infrequent adjustment and is economical.\*

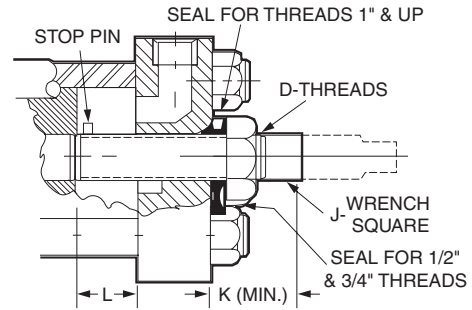

Here a "retracting stroke adjuster" must be called for in specifications, and the length of the adjustment must be specified.

Where frequent adjustment or cushions at the cap end are required, other designs are available according to application needs. Please contact Wadsworth, Ohio facility for more information.

\* Infrequent is defined by positioning the retract stroke in a couple of attempts at original machine set up. The frequent stroke adjuster is recommended for adjustments required after the original equipment has been adjusted by the original machine manufacturer.

Bore Size	D	J	K	L(Max.)
1-1/2, 2	1/2 - 20	5/16	15/16	5
2-1/2, 3-1/4, 4	3/4 - 16	7/16	1-1/4	8
5, 6	1 - 14	5/8	1-11/16	9
8	1-1/2 - 12	15/16	2-1/8	18



## Stop Tubing & Mounting Classes

### Stop Tubing (only with metallic piston)

Long stroke cylinders, fixed or pivot mounted, tend to jackknife or buckle on push load applications, resulting in high bearing loading at the rod gland or piston. Use of a stop tube to lengthen the distance between the gland and piston when cylinder rod is fully extended is recommended to reduce these bearing loads. The drawing below shows stop tube construction for fluid power cylinders. Refer to chart on next page to determine stop tube length.

When specifying cylinders with long stroke and stop tube, be sure to call out the net stroke and the length of the stop tube. Machine design can be continued without delay by laying in a cylinder equivalent in length to the NET STROKE PLUS STOP TUBE LENGTH, which is referred to as GROSS STROKE.

Refer to the next page to determine stop tube length.

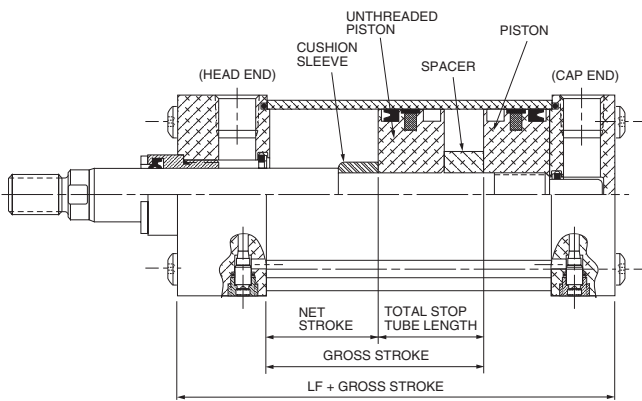

Double piston design is supplied on air cylinders with cushion head end or both ends.

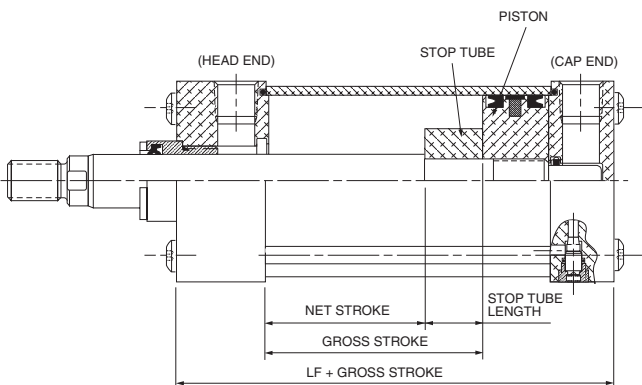

This design is supplied on cushioned cap or non-cushioned cylinders.

### Cushion Selection

Cushions are required when cylinder piston rod speed exceeds 4" per second.

## Pneumatic Actuator Products Application Engineering Data

### Mounting Classes

Standard mountings for fluid power cylinders fall into three basic groups. The groups can be summarized as follows:

**Group 1** – Straight Line Force Transfer with fixed mounts which absorb force on cylinder centerline.

**Group 2** – Pivot Force Transfer. Pivot mountings permit a cylinder to change its alignment in one plane.

**Group 3** – Straight Line Force Transfer with fixed mounts which do not absorb force on cylinder centerline.

Because a cylinder's mounting directly affects the maximum pressure at which the cylinder can be used, the charts below should be helpful in the selection of the proper mounting combination for your application. Stroke length, piston rod connection to load, extra piston rod length over standard, etc. should be considered for thrust loads. Alloy steel mounting bolts are recommended for all mounting styles, and thrust keys are recommended for Group 3.

	<b>Group 1</b>
	FIXED MOUNTS which absorb force on cylinder centerline.
<b>HEAVY-DUTY SERVICE</b>	For Thrust Loads _____ For Tension Loads _____ Mtg. Styles TC Mtg. Styles TB
<b>MEDIUM-DUTY SERVICE</b>	For Thrust Loads _____ For Tension Loads _____ Mtg. Styles H, HB Mtg. Styles J, JB
<b>LIGHT-DUTY SERVICE</b>	For Thrust Loads _____ For Tension Loads _____ Mtg. Styles J, JB Mtg. Styles H, HB
	<b>Group 2</b>
	PIVOT MOUNTS which absorb force on cylinder centerline.
<b>HEAVY-DUTY SERVICE</b>	For Thrust Loads _____ For Tension Loads _____ Mtg. Styles DD, D Mtg. Styles BB, BC, DD, D, DB
<b>MEDIUM-DUTY SERVICE</b>	For Thrust Loads _____ For Tension Loads _____ Mtg. Styles BB, BC, BE Mtg. Styles BB, BC, BE
	<b>Group 3</b>
	FIXED MOUNTS which do not absorb force on the centerline.
<b>HEAVY-DUTY SERVICE</b>	For Thrust Loads _____ For Tension Loads _____ Mtg. Styles C Mtg. Styles C
<b>MEDIUM-DUTY SERVICE</b>	For Thrust Loads _____ For Tension Loads _____ Mtg. Styles F Mtg. Styles F
<b>LIGHT-DUTY SERVICE</b>	For Thrust Loads _____ For Tension Loads _____ Mtg. Styles CB† Mtg. Styles CB†
† Mounting style CB recommended for maximum pressure of 150 PSI.	

A

Product Index,  
Virtual Engineer,  
Engineering Data

Product  
Index

Virtual  
Engineer

Engineering  
Data

**Piston Rod – Stroke Selection Chart**

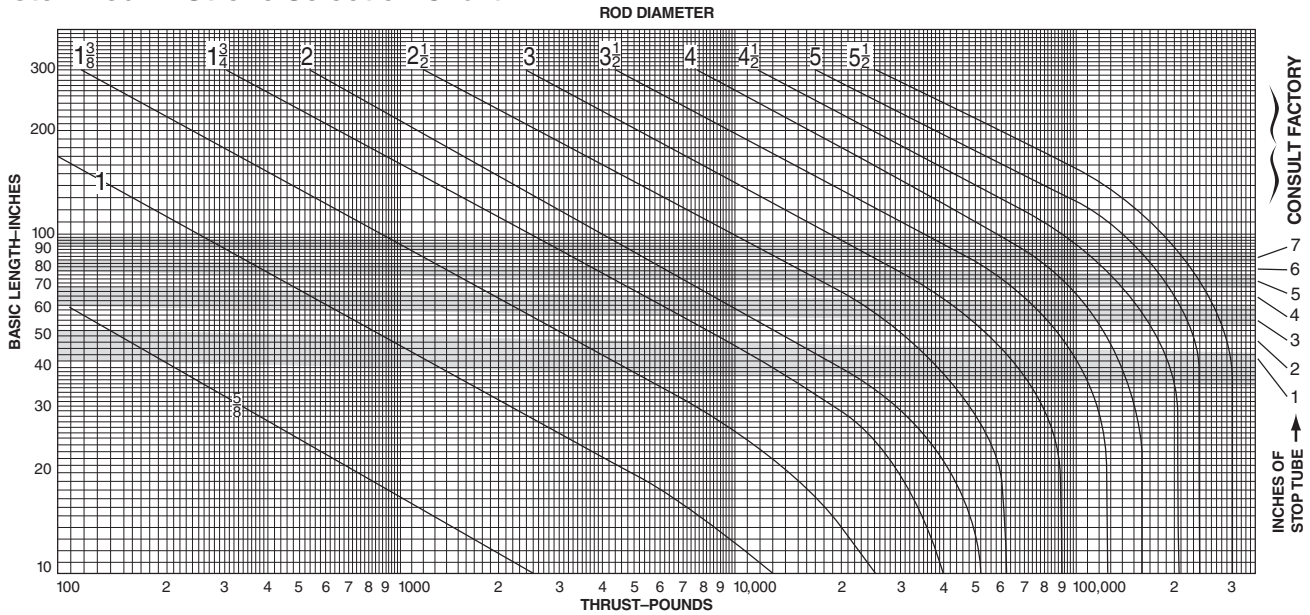

**How to Use the Chart**

The selection of a piston rod for thrust (push) conditions requires the following steps:

- Determine the type of cylinder mounting style and rod end connection to be used. Then consult the chart below and find the "stroke factor" that corresponds to the conditions used.
- Using this stroke factor, determine the "basic length" from the equation:

$$\text{Basic Length} = \frac{\text{Actual Stroke}}{\text{Stroke Factor}}$$

The graph is prepared for standard rod extensions beyond the face of the gland retainers. For rod extensions greater than standard, add the increase to the stroke in arriving at the "basic length."

- Find the load imposed for the thrust application by multiplying the full bore area of the cylinder by the system pressure.
- Enter the graph along the values of "basic length" and "thrust" as found above and note the point of intersection:

A) The correct piston rod size is read from the diagonally curved line labeled "Rod Diameter" next above the point of intersection.

- The required length of stop tube is read from the right of the graph by following the shaded band in which the point of intersection lies.
- If required length of stop tube is in the region labeled "consult factory," submit the following information for an individual analysis:
  - Cylinder mounting style.
  - Rod end connection and method of guiding load.
  - Bore, required stroke, length of rod extension (Dim. "LA or LAF") if greater than standard, and series of cylinder used.
  - Mounting position of cylinder. (Note: If at an angle or vertical, specify direction of piston rod.)
  - Operating pressure of cylinder if limited to less than standard pressure for cylinder selected.

**Warning**

Piston rods are not normally designed to absorb bending moments or loads which are perpendicular to the axis of piston rod motion. These additional loads can cause the piston rod end to fail. If these types of additional loads are expected to be imposed on the piston rods, their magnitude should be made known to our Engineering Department so they may be properly addressed. Additionally, cylinder users should always make sure that the piston rod is securely attached to the machine member.

**Recommended Mounting Styles For Maximum Stroke And Thrust Loads**

**Groups 1 or 3**

Long stroke cylinders for thrust loads should be mounted using a heavy-duty mounting style at one end, firmly fixed and aligned to take the principal force. Additional mounting should be specified at the opposite end, which should be used for alignment and support. An intermediate support may also be desirable for long stroke cylinders mounted horizontally. Machine mounting pads can be adjustable for support mountings to achieve proper alignment.

**Group 2**

Style D — Trunnion on Head

Style DD — Intermediate Trunnion

Style DB — Trunnion on Cap or

Style BB — Clevis on Cap

Rod End Connection	Case	Diagram	Stroke Factor
Fixed and Rigidly Guided	I		0.50
Pivoted and Rigidly Guided	II		0.70
Supported but not Rigidly Guided	III		2.00
Pivoted and Rigidly Guided	IV		1.00
Pivoted and Rigidly Guided	V		1.50
Pivoted and Rigidly Guided	VI		2.00



For inventory, lead times, and kit lookup, visit [www.pdnplu.com](http://www.pdnplu.com)

**A**  
 Product Index, Virtual Engineer, Engineering Data  
 Product Index  
 Virtual Engineer  
 Engineering Data

## Deceleration Force and Air Requirements

Cushion ratings for **Air Cylinders Only** are described in **Table b-2** and **Graph b-1**. To determine whether a cylinder will adequately stop a load without damage to the cylinder, the weight of the load (including the weight of the piston and the piston rod from **Table b-1**) and the maximum speed of the piston rod must first be determined. Once these two factors are known, the **Kinetic Energy Graph** may be used. Enter the graph at its base for the value of weight determined, and project vertically to the required speed value. The point of intersection of these two lines will be the cushion rating number required for the application.

To determine the total load to be moved, the weight of the piston and rod must be included.

**Total Weight** = weight of the piston and non-stroke rod length (column 1) + weight of the rod per inch of stroke x the inches of stroke (Column 2) + the load to be moved.

**Example:** a 3-1/4" bore cylinder with a 1" rod diameter and 25" of stroke; external load to be moved is 85 lbs. Total load to be moved is then (3.3 lbs) + (0.223 lbs/inch X 25 inches) + (85 lbs) for a total of 93.9 lbs.

## Pneumatic Actuator Products Application Engineering Data

**Table b-1**  
**4MA Piston Rod Assembly Weight Table**

Bore	Rod Dia. mm	Column 1 Basic Weight for Piston and Non- Stroke Rod (lbs)	Column 2 Basic Weight for Each 1" of Stroke (lbs)
1-1/2	5/8	1.1	0.087
	1	N/A	N/A
2	5/8	1.2	0.087
	1	2.1	0.223
2-1/2	5/8	1.5	0.087
	1	2.3	0.223
3-1/4	1	3.3	0.223
	1-3/8	4.9	0.421
4	1	3.8	0.223
	1-3/8	5.4	0.421
5	1	5.0	0.223
	1-3/8	6.5	0.421
6	1-3/8	8.3	0.421
	1-3/4	11.8	0.682
8	1-3/8	12.4	0.421
	1-3/4	15.0	0.682

Note: aluminum piston used for weight calculation

**Graph b-1**  
**Kinetic Energy Graph – Air Cylinders**

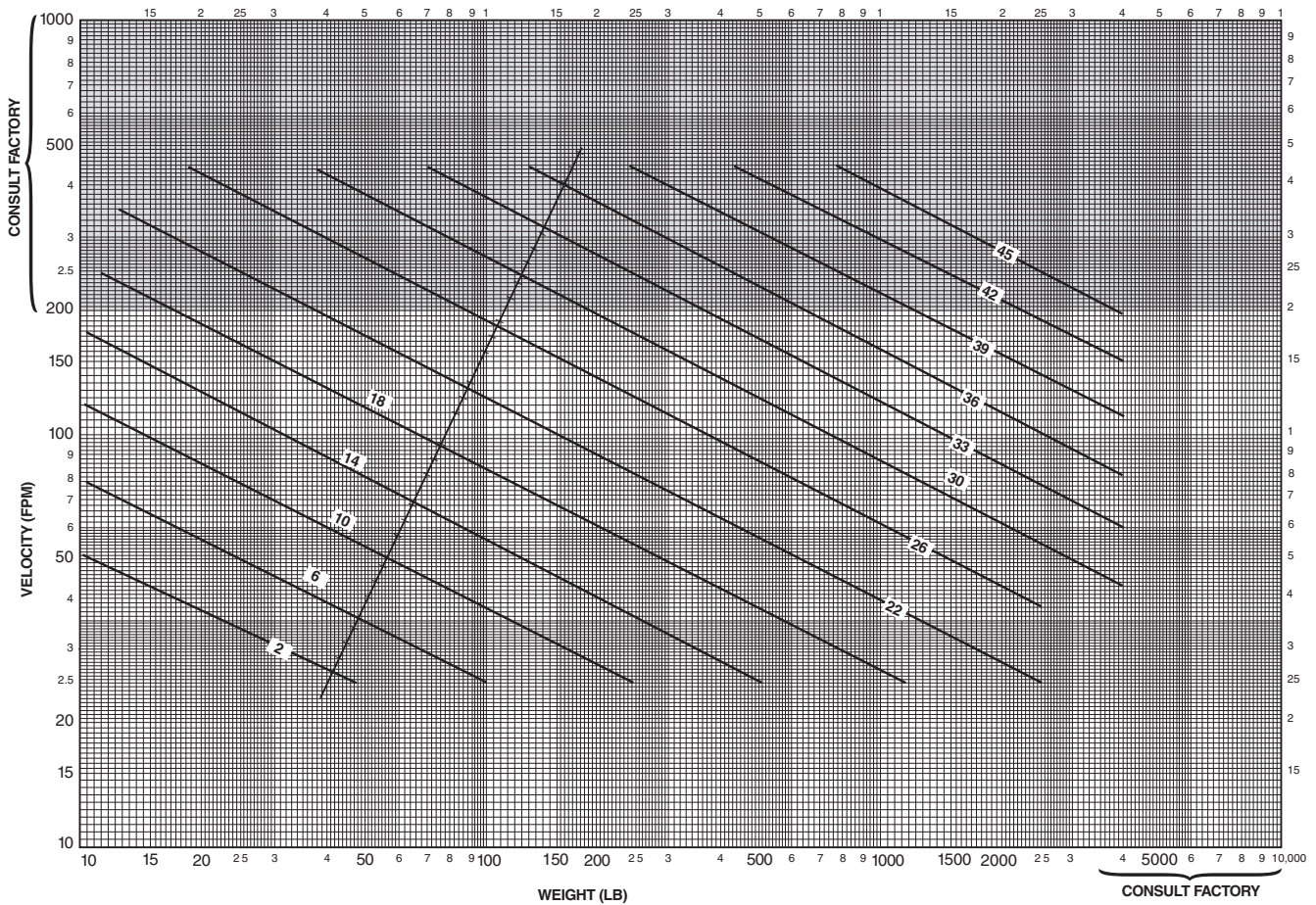

**A**

Product Index,  
Virtual Engineer,  
Engineering Data

Product  
Index

Virtual  
Engineer

Engineering  
Data



## Cushion Ratings and Air Requirements

Now refer to **Table b-2** and find the cushion ratings, using bore size and rod diameter of the cylinder selected. If a simple circuit is used, with no meter out or speed control, use the "Rating with No Back Pressure" column values. If a meter out or speed control is to be used, use the "Rating with Back Pressure" column values. If the cushion rating found in **Table b-2** below is **greater** than the number determined in **Graph b-1**, then the cylinder will stop the load adequately. If the cushion rating in **Table b-2** is **smaller** than the number found in **Graph b-1**, then a larger bore cylinder should be used. In those applications where back pressures exist in the exhaust lines, it is possible to exceed the cushion ratings shown in **Table b-2**. In these cases, consult the factory and advise the amount of back pressure.

**Table b-2**  
**4MA Air Cylinder Cushion Ratings Table**

Bore	Rod Dia. mm	Rating with No Back Pressure	Rating with Back Pressure
1-1/2	5/8	8	14
	1	N/A	N/A
2	5/8	12	18
	1	9	15
2-1/2	5/8	14	20
	1	14	19
3-1/4	1	18	24
	1-3/8	17	23
4	1	20	27
	1-3/8	20	26
5	1	23	28
	1-3/8	23	28
6	1-3/8	26	31
	1-3/4	26	31
8	1-3/8	29	35
	1-3/4	29	34

In general, if the cushion rating number from the Kinetic Energy Graph is greater than the cushion rating for a particular bore and rod diameter, other and external means of decelerating the load will be necessary for proper cylinder application. Parker options include shock absorbers, Par-Check hydraulic resistance units and NuCushion bumpers.

## Pneumatic Actuator Products Application Engineering Data

Shock absorbers provide the greatest selection of decelerating products, and many can be incorporated into the cap end of cylinders for retract stroke deceleration. Additional product information can be found in Industrial Shock Absorbers Catalog AU08-1022-1/NA, and please contact the Wadsworth, OH facility for cylinder modification details.



Shock Absorber



NuCushion Bumper  
2-1/2" - 4" Bores

### Inch Based Cylinders Air Requirement Per Inch of Cylinder Stroke

The amount of air required to operate a cylinder is determined from the volume of the cylinder and its cycle in strokes per minute. This may be determined by use of the following formulae which apply to a single-acting cylinder.

$$V = \frac{3.1416 L D^2}{4} \quad C = \frac{fV}{1728}$$

- Where:
- V = Cylinder volume, cu. in.
  - L = Cylinder stroke length, in.
  - D = Internal diameter of cylinder in.
  - C = Air required, cfm
  - f = Number of strokes per minute

The air requirements for a double-acting cylinder is almost double that of a single-acting cylinder, except for the volume of the piston rod.

**A**  
Product Index,  
Virtual Engineer,  
Engineering Data





The air flow requirements of a cylinder in terms of cfm should not be confused with compressor ratings which are given in terms of free air. If compressor capacity is involved in the consideration of cylinder air requirements it will be necessary to convert cfm values to free air values. This relationship varies for different gauge pressures.

Thrust (pounds) = operating pressure x area of cylinder bore.

**Note:** That on the "out" stroke the air pressure is working on the entire piston area but on the "in" stroke the air pressure works on the piston area less the rod area.

**Graph b-2** and **b-3** offer a simple means to select pneumatic components for dynamic cylinder applications. It is only necessary to know the force required, the desired speed and the pressure which can be maintained at the inlet to the air preparation system. The graphs assume average conditions relative to air line sizes, system layout, friction, etc. At higher speeds, consider appropriate cushioning of cylinders.

The general procedure to follow when using these graphs is:

1. Select the appropriate graph depending upon the pressure which can be maintained to the system – **Graph b-2** for 100 PSIG and **Graph b-3** for 80 PSIG.
2. Determine appropriate cylinder bore. Values underneath the diagonal cylinder bore lines indicate the maximum recommended dynamic thrust developed while the cylinder is in motion. The data in the table at the bottom of each graph indicates available static force applications in which clamping force is a prime consideration in determining cylinder bore. Please reference table number b-3 and b-4 for approximate thrust developed at a given operating pressure.

**Graph b-2**

THIS GRAPH IS DETERMINED BY HAVING 100 PSIG AVAILABLE UNDER FLOWING CONDITIONS.

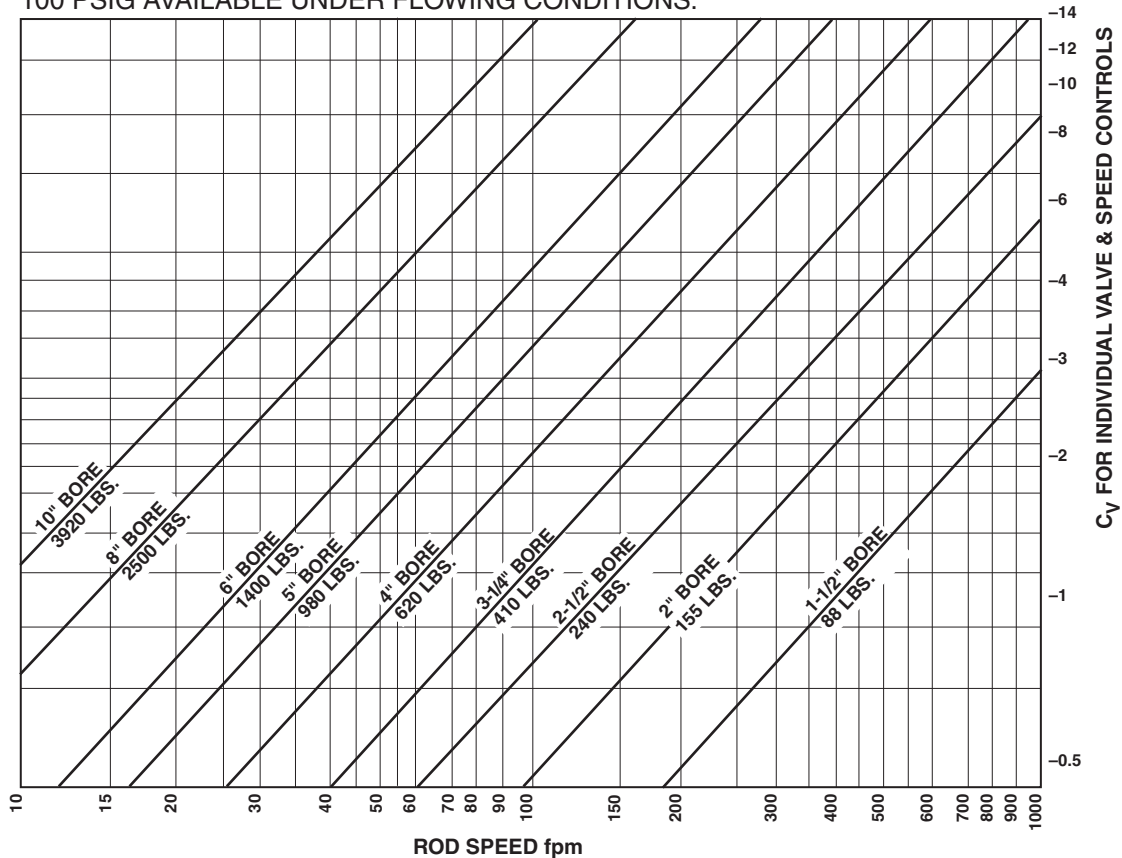

**Table b-3**  
**Thrust Developed**

Bore Size	1-1/2"	2"	2-1/2"	3-1/4"	4"	5"	6"	8"
Dynamic Thrust (lbs.)	88	155	240	410	620	980	1400	2500
Static Thrust (lbs.)	177	314	491	830	1250	1960	2820	5020

**A**  
 Product Index,  
 Virtual Engineer,  
 Engineering Data

---

Product Index

---

Virtual Engineer

---

Engineering Data



For inventory, lead times, and kit lookup, visit [www.pdnplu.com](http://www.pdnplu.com)

- Read upward on appropriate rod speed line to intersection with diagonal cylinder bore line. Read right from inter-section point to determine the required  $C_v$  of the valve and the speed controls. Both the valve and speed controls must have this  $C_v$ .

The following examples illustrate use of the graphs:

**Example 1:** Assume it is necessary to raise a 900-pound load 24 inches in two seconds. With 100 PSIG maintained at the inlet to the air preparation system, use **Graph b-2**. The 5-inch bore cylinder is capable of developing the required thrust while in motion. Since 24 inches in two seconds is equal to 60 fpm, read upward on the 60 fpm line to the intersection of the 5-inch bore diagonal line. Reading to the right indicates that the required valve and speed controls must each have a  $C_v$  of over 1.9.

**Example 2:** Assume similar conditions to Example 1 except that only 80- PSIG will be available under flowing conditions. Using **Graph b-3**, a 6-inch bore cylinder is indicated. Read upward on the 60 fpm line to the intersection point. Interpolation of the right-hand scale indicates a required valve and speed control  $C_v$  of over 2.8.

**Example 3:** Assume similar conditions to Example 1 except that the load is being moved in a horizontal plane with a coefficient of sliding friction of 0.2. Only a 180-pound thrust is now required (900 lb. x 0.2). Consult **Graph b-3**. The 2-1/2 inch bore cylinder will develop sufficient thrust, and at 60 fpm requires a valve and speed control  $C_v$  of about 0.5.

**Graph b-3**

THIS GRAPH IS DETERMINED BY HAVING 80 PSIG AVAILABLE UNDER FLOWING CONDITIONS.

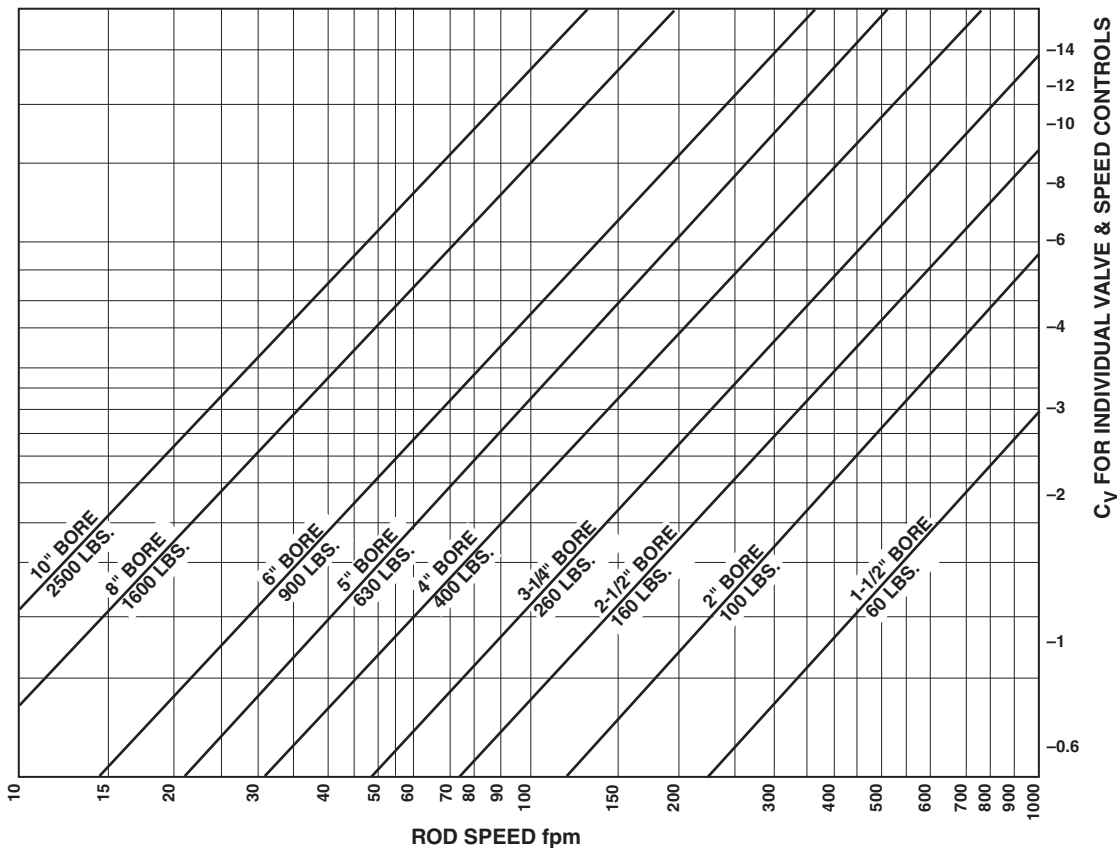

**Table b-4**  
**Thrust Developed**

Bore Size	1-1/2"	2"	2-1/2"	3-1/4"	4"	5"	6"	8"
Dynamic Thrust (lbs.)	60	100	160	260	400	630	900	1600
Static Thrust (lbs.)	141	251	393	663	1000	1570	2260	4010

## Rod End Data

Rod end dimension symbols as shown comply with the National Fluid Power Association dimensional code. The following chart indicates the symbols used in this catalog.

Description	Symbol
Thread diameter and pitch	KK or CC
Length of thread	A
Length of rod extension from face of gland retainer to end of retracted rod	LA or LAF (Male Thread) W or WF (Female Thread)

Five rod ends for Parker cylinders are offered as shown on the dimension pages of this catalog. They are Parker styles 4, 6, 8, 9 and 55, and all five are optional without price penalty.

### Warning

Piston rods are not normally designed to absorb bending moments or loads which are perpendicular to the axis of piston rod motion. These additional loads can cause the piston rod end to fail. If these types of additional loads are expected to be imposed on the piston rods, their magnitude should be made known to our Application Engineering Department so they may be properly addressed. Additionally, cylinder users should always make sure that the piston rod is securely attached to the machine member.

On occasion cylinders are ordered with double rods. In some cases a stop is threaded onto one of the piston rods and used as an external stroke adjuster. This can cause a potential safety concern and can also lead to premature piston rod failure. The external stop will create a pinch point and the cylinder user should consider appropriate use of guards. If an external stop is not parallel to the final contact surface it will place a bending moment on the piston rod. An external stop will also negate the effect of a cushion and will subject the piston rod to an impact loading. These two (2) conditions can cause piston rod failure. The use of external stroke adjusters should be reviewed with our Application Engineering Department.

## Piston Rod End Threads

Standard piston rod end thread lengths are shown as dimension "A" in Catalog dimension pages. Special rod end threads which are two times standard length can be supplied at a small extra cost. Available thread lengths are shown in the table below. To order, add suffix "2" to piston rod model number code and specify as Style #42 or Style #82.

### Optional Piston Rod End Studs

Piston Rod Dia.	Rod End Thread Style #42		Rod End Thread Style #82	
	Thread Dia. & Pitch (KK)	Length (= 2 × A)	Thread Dia. & Pitch (CC)	Length (= 2 × A)
5/8	7/16-20	1-1/2	1/2-20	1-1/2
1	3/4-16	2-1/4	7/8-14	2-1/4
1-3/8	1-14	3-1/4	1-1/4 - 12	3-1/4
1-3/4	1-1/4 - 12	4	1-1/2 - 12	4

## International Rod End Threads

Piston rod threads to meet international requirements are available at extra cost. Parker cylinders can be supplied with British standard fine (W) or metric (M). To order, specify in model number. For dimensions, consult factory.

## Special Rod Ends

If a rod end configuration other than the standard styles is required, such special rod ends can be provided. The designation "Style 3" is assigned to such specials and is incorporated in the cylinder model number. To order, specify "Style 3" and give desired dimensions for KK; A; LA, LAF, W, or WF. If otherwise special, send a dimensioned sketch.

## Special Assemblies from Standard Parts

Each dimensioned drawing in this catalog has position numbers shown on the end view to identify the four sides of the cylinder. These aid in communications and simplify the writing of specifications that cover changes in port positions, etc. Following are several suggested special assemblies that can be made up from standard parts.

- By calling out the position numbers for the desired locations for head and cap ports, many mounting styles can be assembled with ports located at 90° or 180° from standard. In such special assemblies, the cushion needle valves are also repositioned since their relation with the port position does not change.
- On mounting styles D, DB and DD, the cushion needle valves are provided only on the side position 3 on the head or cap which accommodates the mounting. The opposite head or cap can be rotated.
- Standard mountings in different combinations can be provided: for example Style J mounting on head end with Style C on the cap end. This would be made up from standard parts and would be designated Model (bore size) **JC-4MAU14A** (stroke).

## Single-Acting Cylinders

Double-acting cylinders are supplied as standard. They can also be used as single-acting cylinders where air or hydraulic force is applied to only one side of the piston, with the load or other external forces acting to "return" the piston after pressure is exhausted.

## Spring-Returned, Single-Acting Cylinders (only with metallic piston)

Single-acting, spring-returned models can also be provided. Load conditions and friction factors must be considered in supplying the proper spring for the application. In addition, it is necessary that information be supplied as to which side of the piston the spring should act upon. Specify "Spring to return piston rod" or "Spring to advance piston rod."

On longer stroke spring-returned cylinders, it is recommended that tie rod extensions be specified on the cylinder end in which the spring is located so that the cap or head against which the spring is acting can be "backed-off" slowly until compression of the spring is relieved. In such cases it should also be specified that the tie rod nuts be welded to the tie rods at the opposite end of the cylinder to further insure safe disassembly.

Consult factory when ordering spring-returned cylinders.

A

Product Index,  
Virtual Engineering,  
Engineering DataProduct  
IndexVirtual  
EngineerEngineering  
Data

For inventory, lead times, and kit lookup, visit [www.pdnplu.com](http://www.pdnplu.com)

**A**

**Product Index,  
Virtual Engineer,  
Engineering Data**

**Product  
Index**

**Virtual  
Engineer**

**Engineering  
Data**

**Modifications**

The following modifications can be supplied on most cylinders.

**Metallic Rod Wiper Gland Assembly**

When specified metallic rod wipers can be supplied instead of the standard wiper. Recommended in applications where contaminants tend to adhere to the extended piston rod and would damage the standard wiper. Installation of metallic rod wiper does not affect cylinder dimensions. It is available at extra cost. Please contact the Wadsworth, OH facility for more information.

**Rod End Boots**

Most Parker cylinders have a hardened bearing surface on the standard piston rod to resist external damage, and are equipped with a high efficiency wiper to remove external dust and dirt. Exposed piston rods that are subjected to contaminants with air hardening properties, such as paint, should be protected. In such applications, the use of a collapsing cover should be considered. This is commonly referred to as a "boot". Calculate the longer rod end required to accommodate the collapsed length of the boot from the following data.

<b>RD</b>	1/2	5/8	1	1-3/8	1-3/4
<b>OD</b>	2-1/4	2-1/4	2-5/8	3	3-3/8
<b>LF</b>	.13	.13	.13	.13	.13

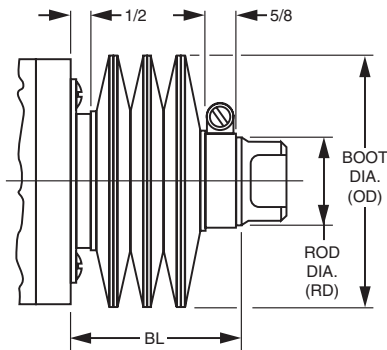

To determine extra length of piston rod required to accommodate boot, calculate:

$$BL = \text{Stroke} \times LF + 1-1/8"$$

BL + std LAF (male rod end) or WF (female rod end) dimension = length of piston rod to extend beyond the head face.

**Note:** Please compare the Boot OD size to the standard E dimension per desired cylinder series and bore. This may be critical for foot mounted cylinders.

Rod Boots are available for many cylinder series. Please contact the Wadsworth, OH facility for rod boot options.

**Tandem Cylinders**

A tandem cylinder is made up of two cylinders mounted in line with pistons connected by a common piston rod and rod seals installed between the cylinders to permit double acting operation of each. Tandem cylinders allow increased output force when mounting width or height are restricted. Please contact the Wadsworth, OH facility for more information.

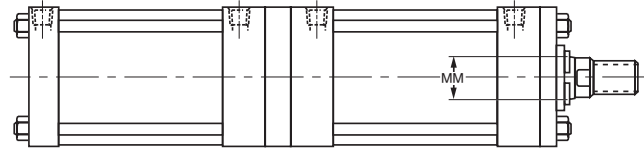

**Duplex Cylinders**

A duplex cylinder is made up of two cylinders mounted in line with pistons not connected and with rod seals installed between the cylinders to permit double acting operation of each. Cylinders may be mounted with piston rod to piston (as shown) or back to back and are generally used to provide three position operation. Please contact the Wadsworth, OH facility for more information.

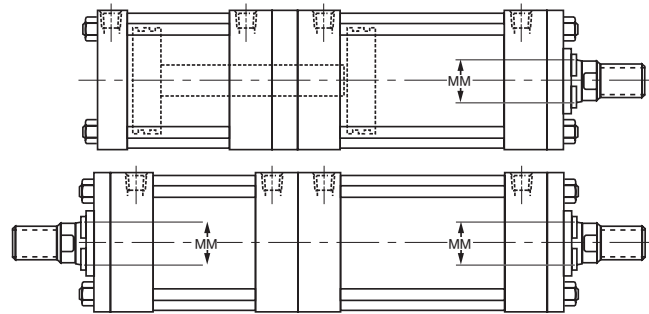

For inventory, lead times, and kit lookup, visit [www.pdnplu.com](http://www.pdnplu.com)



## Design Torque

Design torque represents the maximum torque that an actuator must supply in an application. This maximum is the greater of the Demand Torque or the Cushion Torque. If the demand torque exceeds what the actuator can supply, the actuator will either move too slowly or stall. If the cushion torque is too high, the actuator may be damaged by excessive pressure. Demand torque and cushion torque are defined below in terms of load, friction, and acceleration torque.

Equations for calculating demand torque and cushion torque for some general applications are provided on the following pages.

## T - Torque

The amount of turning effort exerted by a rotary actuator.

### T<sub>D</sub> - Demand Torque

This is the torque required from the actuator to do the job and is the sum of the load torque, friction torque, and acceleration torque, multiplied by an appropriate design factor. Design factors vary with the applications and the designers' knowledge.

$$\text{Equation 4-3) } T_D = T_\alpha + T_f + T_L$$

### T<sub>L</sub> - Load torque

This is the torque required to equal the weight or force of the load. For example, in Fig. 4-8a, the load torque is 563 Nm (5000 lb-in); in Fig. 4-8b the load torque is zero; in Fig. 4-8c the load torque is 563 Nm (5000 lb-in). The load torque term is intended to encompass all torque components that aren't included in the friction or acceleration terms.

### T<sub>f</sub> - Friction torque

This is the torque required to overcome friction between any moving parts, especially bearing surfaces. In Fig. 4-8a, the friction torque is zero for the hanging load; in Fig. 4-8b the friction torque is 775 Nm (6880 lb-in) for the sliding load; in Fig. 4-8c the friction torque is zero for the clamp.

$$\text{Equation 4-4) } T_f = \mu W r$$

### T<sub>a</sub> - Acceleration Torque

This is the torque required to overcome the inertia of the load in order to provide a required acceleration or deceleration. In Fig. 4-8a the load is suspended motionless so there is no acceleration. In Fig. 4-8b, the load is accelerated from 0 to some specified angular velocity. If the mass moment of inertia about the axis of rotation is I and the angular acceleration is a, the acceleration torque is equal to Ia. In Fig. 4-8c there is no acceleration.

Some values for mass moment of inertia are given in Table 4.

Some useful equations for determining a are listed in Table 5. Equation 5 below shows the general equation for acceleration torque.

$$\text{Equation 4-5) } T_\alpha = I\alpha$$

## T<sub>c</sub> - Cushion Torque

This is the torque that the actuator must apply to provide a required deceleration. This torque is generated by restricting the flow out of the actuator (meter-out) so as to create a back pressure which decelerates the load. This back pressure (deceleration) often must overcome both the inertia of the load and the driving pressure (system pressure) from the pump. See applications.

$$\text{Equation 4-6) } T_c = T_\alpha + \frac{P_r V}{\theta} - T_f \pm T_L$$

The friction torque T<sub>f</sub> reduces the torque the actuator must apply to stop the load. The load torque T<sub>L</sub> may add to, or subtract from the torque required from the actuator, depending upon the orientation of the load torque. For example, a weight being swung upward would result in a load torque that is subtracted.

**Warning: Rapid deceleration can cause high pressure intensification at the outlet of the actuator. Always insure that cushion pressure does not exceed the manufacturer's pressure rating for the actuator.**

## KE - Kinetic Energy (1/2 Jmω<sup>2</sup>)

This is the amount of energy that a rotating load has. The rotator must be able to stop the load. All products have kinetic energy rating tables. Choose the appropriate deceleration option (i.e., bumper, cushions, shock absorbers, etc.) that meets or exceeds the kinetic energy of the load.

A

Product Index,  
Virtual Engineer,  
Engineering DataProduct  
IndexVirtual  
EngineerEngineering  
Data

**Pages A21-A22 and A24-A25 excerpted  
from the Parker Hannifin Design  
Engineers Handbook.**



For inventory, lead times, and kit lookup, visit [www.pdnplu.com](http://www.pdnplu.com)

**Demand Torque Examples**

**A**

**A) Example of load torque**

The load is held motionless as shown.

$$T_D = T_\alpha + T_f + T_L$$

$$T_\alpha = 0$$

$$T_f = 0$$

$$T_L = (500 \text{ lb})(10 \text{ in}) = 5,000 \text{ lb-in}$$

$$T_D = 5,000 \text{ lb-in}$$

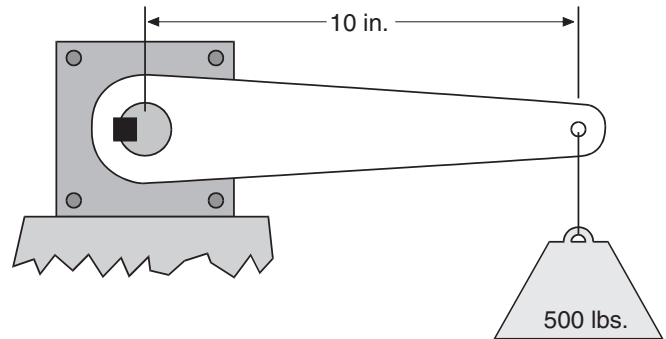

Figure 4-8a

**B) Due to friction and acceleration**

The 500 lb rotating index table is supported by bearings with a coefficient of friction of 0.25. The table's acceleration  $a$  is  $2 \text{ rad/sec}^2$ . The table's mass moment of inertia  $I$  is  $2,330 \text{ lb-in-sec}^2$ .

$$T_D = T_\alpha + T_f + T_L$$

$$T_\alpha = I\alpha = (2,330 \text{ lb-in-sec}^2)(2/\text{sec}^2) = 4,660 \text{ lb-in}$$

$$T_f = \mu W r_b = 0.25 (500 \text{ lb})(55 \text{ in}) = 6,880 \text{ lb-in}$$

$$T_L = 0$$

$$T_D = 4,660 \text{ lb-in} + 6,880 \text{ lb-in} = 11,540 \text{ lb-in}$$

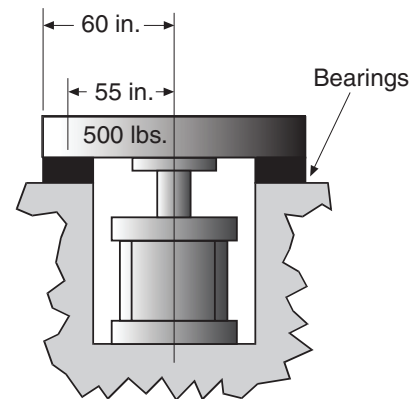

Figure 4-8b

**C) Load torque example**

$$T_D = T_\alpha + T_f + T_L$$

$$T_\alpha = 0$$

$$T_f = 0$$

$$T_L = (500 \text{ lb})(10 \text{ in}) = 5,000 \text{ lb-in}$$

$$T_D = 5,000 \text{ lb-in}$$

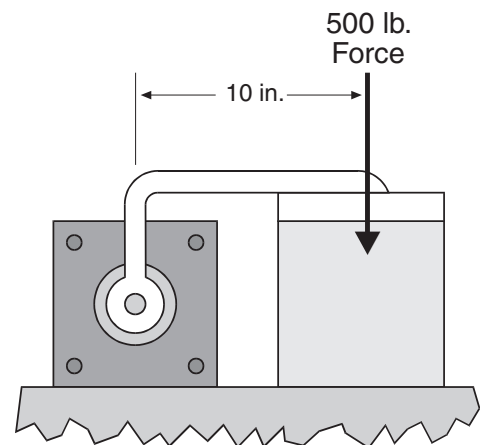

Figure 4-8c

Product Index,  
Virtual Engineer,  
Engineering Data

Product  
Index

Virtual  
Engineer

Engineering  
Data

**Torque Selection**

Parker rotary actuators provide output torque up to 10,000 lb-in. The chart to the right shows the nominal torque output range of various actuator models at 100 PSI.

**Caution:**

This chart is intended as a guide only. Refer to actual product data in this catalog before specifying an actuator. Factors such as pressure rating, rotation, and actual torque output may be affected by specific product details and options.

**Nominal Torque at 100 PSI**

Output Torque (lb-in)	Rotation < 95°		Rotation > 100°	
	Vane Models	Rack & Pinion Models	Vane Models	Rack & Pinion Models
10000		HP10		HP10
9000				
8000				
7000				
6000				
5000		HP4.5		HP4.5
4000				
3500				
3000	PRN800D	B6714		B6714
2500		PTR322		PTR322
2000	PV46D			
1750				
1500	PRN800S		PRN800S	
1250	PV44D	PTR321, B6713		PTR321, B6713
1000				
900	PRN300D	PTR252	PV46	PTR252
800				
700	PV36D, PV42D			
600		PTR202, B6712	PV44	PTR202, B6712
500	PV42D, PRN150D	PTR251		PTR251
400	PV33D, PRN300S		PV36, PRN300S	
300		PTR201	PV42	PTR201
250		PTR152		PTR152
200	PRN150S		PV33, PRN150S	
150	PV22D, PRN50D	PTR151, B6711		PTR151, B6711
100	PRN30D			
80		PTR102	PV22	PTR102
60	PRN50S		PRN50S	
40	PRN30S	PTR101	PRN30S	PTR101
35	PV11D			
30				
25	PRNA20S		PRNA20S	
20	PV10D			
15	PRNA10S		PV11, PRNA10S	
10			PV10	
5	PRNA1S, PRNA3S		PRNA1S, PRNA3S	
0				

**A**

Product Index,  
Virtual Engineer,  
Engineering Data

Product  
Index

Virtual  
Engineer

Engineering  
Data



For inventory, lead times, and kit lookup, visit [www.pdnplu.com](http://www.pdnplu.com)

Table 4: Mass Moments of Inertia

**A**  
 Product Index,  
 Virtual Engineer,  
 Engineering Data  

---

 Product  
 Index  

---

 Virtual  
 Engineer  

---

 Engineering  
 Data

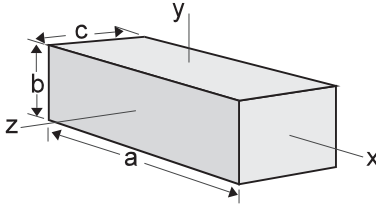
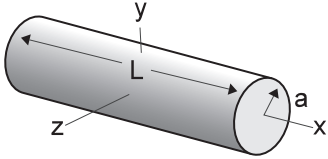
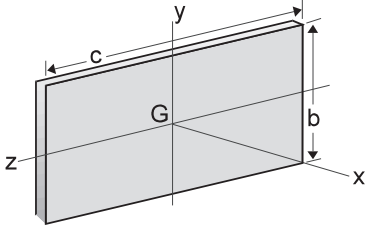
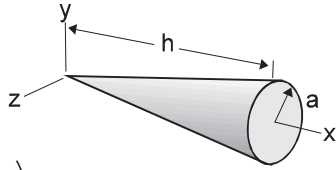
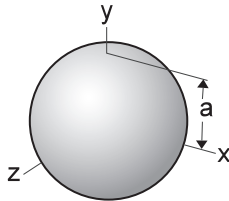
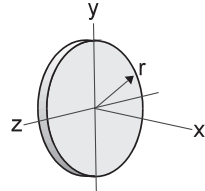
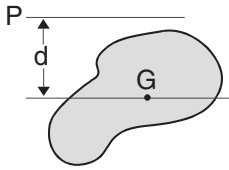
<p><b>Rectangular prism</b></p> $I_x = \frac{1}{12} m(b^2 + c^2)$ $I_y = \frac{1}{12} m(c^2 + a^2)$ $I_z = \frac{1}{12} m(a^2 + b^2)$ 	<p><b>Circular cylinder</b></p>  $I_x = \frac{1}{2} ma^2$ $I_y = I_z = \frac{1}{12} m(3a^2 + L^2)$
<p><b>Thin rectangular plate</b></p> $I_x = \frac{1}{12} m(b^2 + c^2)$ $I_y = \frac{1}{12} mc^2$ $I_z = \frac{1}{12} mb^2$ 	<p><b>Circular cone</b></p>  $I_x = \frac{3}{10} ma^2$ $I_y = I_z = \frac{3}{5} m\left(\frac{1}{4}a^2 + h^2\right)$
<p><b>Sphere</b></p> $I_x = I_y = I_z = \frac{2}{5} ma^2$ 	<p><b>Thin disk</b></p>  $I_x = \frac{1}{2} mr^2$ $I_y = I_z = \frac{1}{4} mr^2$
<p><b>Parallel Axis Theorem:</b></p> $I_p = \bar{I} + md^2$ 	<p> <math>I_p</math> = Mass moment of inertia about an axis parallel to a centroidal axis  <math>\bar{I}</math> = Mass moment of inertia about a centroidal axis  <math>m</math> = Mass  <math>d</math> = Distance between axes         </p>
<p><b>When acceleration is constant:</b></p> $\theta = \omega_0 t + \frac{1}{2} \alpha t^2$ $\alpha = \frac{2\theta}{t^2}$ $\theta = \omega_0 t + \frac{1}{2} \omega_t t$ $\alpha = \frac{(\omega_t - \omega_0)^2}{2\theta}$ $\omega = \omega_0 + \alpha t$ $\alpha = \frac{(\omega_t - \omega_0)}{t}$ $\omega = (\omega_0^2 + 2\alpha\theta)^{1/2}$	<p><b>When velocity is constant:</b></p> $\theta = \omega t$ <p> <math>t</math> = time  <math>\theta</math> = angular position  <math>\omega_t</math> = angular velocity at time = <math>t</math>  <math>\omega_0</math> = angular velocity at time = <math>0</math>  <math>\alpha</math> = angular acceleration         </p>

**Basic Velocity, Acceleration, Kinetic Energy And Torque Equations**

*Equations below are based on triangular velocity profile.*

$$\omega_{\max} = .035 \times \frac{\Theta}{t}$$

$$\alpha = \frac{\omega_{\max}^2}{\left(\frac{\Theta}{57.3}\right)}$$

$$\alpha = \frac{\omega_{\max}}{(t/2)}$$

$$K.E. = 1/2 J_m \omega^2$$

$$T_a = \alpha \times J_m$$

$$T_f = W \times U_s \times \left(\text{Distance from pivot point to center of external bearings}\right)$$

$$T_L = \left(\text{Torque arm length to C.G. of load}\right) \times WL \times \cos(\phi)$$

Where  $\phi$  = Angle between torque arm and horizontal plane

Where:

$\Theta$  = Angle of Rotation (Degrees)

t = Time to rotate through  $\Theta$  (sec)

$\omega$  = Angular velocity, radians/sec

$\alpha$  = Angular accelerations (radians/sec<sup>2</sup>)

WL = Weight of load (lbf)

T<sub>a</sub> = Torque to accelerate load (lb-in)

U<sub>s</sub> = Coefficient of static friction

J<sub>m</sub>\* = Rotational mass moment of inertia (lb-in-sec<sup>2</sup>)

T<sub>f</sub> = Torque to overcome friction (lb-in)

T<sub>L</sub> = Torque to overcome effects of gravity

\*Use "I" values from Table 4.

**Coefficients of Friction**

Material*	$\mu_s$	$\mu_k$
Steel on Steel	0.80	0.40
Steel on Steel (lubricated)	0.16	0.03
Aluminum on Steel	0.45	0.30
Copper on Steel	0.22	0.22
Brass on Steel	0.35	0.19
PTFE on Steel	0.04	0.04

\*dry contact unless noted

**A**

Product Index,  
Virtual Engineer,  
Engineering Data

Product  
Index

Virtual  
Engineer

Engineering  
Data



**A**

**Force Conversion Factors**

Multiply value A by conversion factor in table to calculate value B.

A \ B	oz	lbf	N	kg(f)
oz	1	0.0625	0.2780	0.0284
lbf	16	1	4.4482	0.4536
N	3.5970	0.2248	1	0.1020
kg(f)	35.2740	2.2050	9.8068	1

**Torque Conversion Factors**

Multiply value A by conversion factor in table to calculate value B.

A \ B	oz-in	lb-in	lb-ft	Nm
oz-in	1	0.0625	5.2083E-03	7.0616E-03
lb-in	16	1	0.0833	0.1130
lb-ft	192	12	1	1.356
Nm	141.61	8.8507	0.7376	1

**Rotational Inertia Conversion Factors**

Multiply value A by conversion factor in table to calculate value B.

A \ B	oz-in <sup>2</sup>	oz-in-sec <sup>2</sup>	lb-in <sup>2</sup>	lb-in-sec <sup>2</sup>	lb-ft <sup>2</sup>	lb-ft-sec <sup>2</sup>	kg-m <sup>2</sup>	kg-m-sec <sup>2</sup>	kg-cm <sup>2</sup>	kg-cm-sec <sup>2</sup>
oz-in <sup>2</sup>	1	2.5900E-03	6.2500E-02	1.6190E-04	4.3403E-04	1.3490E-05	1.8290E-05	1.8650E-06	1.8290E-01	1.8650E-04
oz-in-sec <sup>2</sup>	3.8610E+02	1	2.4130E+01	6.2500E-02	1.6760E-01	5.2080E-03	7.0620E-03	7.2010E-04	7.0620E+01	7.2010E-02
lb-in <sup>2</sup>	1.6000E+01	4.1442E-02	1	2.5900E-03	6.9444E-03	2.1583E-04	2.9260E-04	2.9840E-05	2.9260E+00	2.9840E-03
lb-in-sec <sup>2</sup>	6.1767E+03	1.6000E+01	3.8610E+02	1	2.6810E+00	8.3333E-02	1.1300E-01	1.1520E-02	1.1300E+03	1.1520E+00
lb-ft <sup>2</sup>	2.3040E+03	5.9666E+00	1.4400E+02	3.7300E-01	1	3.1080E-02	4.2140E-02	4.2970E-03	4.2140E+02	4.2970E-01
lb-ft-sec <sup>2</sup>	7.4129E+04	1.9201E+02	4.6333E+03	1.2000E+01	3.2175E+01	1	1.3560E+00	1.3824E-01	1.3560E+04	1.3824E+01
kg-m <sup>2</sup>	5.4675E+04	1.4160E+02	3.4176E+03	8.8496E+00	2.3730E+01	7.3746E-01	1	1.0190E-01	1.0000E+04	1.0190E+01
kg-m-sec <sup>2</sup>	5.3619E+05	1.3887E+03	3.3512E+04	8.6806E+01	2.3272E+02	7.2338E+00	9.8135E+00	1	9.8130E+04	1.0000E+02
kg-cm <sup>2</sup>	5.4675E+00	1.4160E-02	3.4176E-01	8.8496E-04	2.3730E-03	7.3746E-05	1.0000E-04	1.0191E-05	1	1.0190E-03
kg-cm-sec <sup>2</sup>	5.3619E+03	1.3887E+01	3.3512E+02	8.6806E-01	2.3272E+00	7.2338E-02	9.8135E-02	1.0000E-02	9.8135E+02	1

**Length/Distance Conversion Factors**

Multiply value A by conversion factor in table to calculate value B.

A \ B	in	ft	mm	cm	m
in	1	0.0833	25.4	2.54	0.0254
ft	12	1	304.8	30.48	0.3048
mm	0.03937	0.00328	1	0.1	0.001
cm	0.3937	0.03281	10	1	0.01
m	39.37	3.281	1000	100	1

Product Index,  
 Virtual Engineer,  
 Engineering Data

Product  
 Index

Virtual  
 Engineer

Engineering  
 Data



For inventory, lead times, and kit lookup, visit [www.pdnplu.com](http://www.pdnplu.com)

**Tie Rod  
Pneumatic Cylinders**

**4MA / 4ML Series - Non-Lube NFPA Air Cylinders**

**1-1/2" to 5" Bore Sizes**

Features / Ordering Information	B2-B3
Mounting Styles	B4
Body Orientations	B5
Specifications	B6-B8
Dimensional Data	B9-B17
Accessories / Service Kits	B34-B35

**6" to 8" Bore Sizes**

Features / Ordering Information	B18-B19
Mounting Styles	B20
Specifications	B21-B23
Dimensional Data	B24-B33
Accessories / Service Kits	B34-B35

**4MAJ Series (Rod Lock Option)**

Features / Ordering Information	B36-B39
Mounting Styles	B40
Specifications	B41-B42
Dimensional Data	B43-B61

ACVB Option - Valve Mounted to Cylinder B62-B70

LPSO Option - Linear Position Sensor B71-B76

Standard Options B77-B78

Accessories B79-B80

Maintenance and Service Kits B81-B90



**P1D ISO Pneumatic Cylinders**

Features	B91-B93
Ordering Information	B94
Specifications	B95-B967
Technical Data	B97-B99
Dimensional Data	B100-B104
Rod End Dimensions (Mounting and Rod End Kits)	B105
Tandem and Duplex Cylinders	B106
Accessories / Service Kits	B107-B115



**PIF Profile Pneumatic Cylinders**

Features	B116-B117
Ordering Information	B118
Technical Data	B119-B125
Dimensional Data	B126-B129
Accessories / Service Kits	B130-B141



**2MNR Non-Rotating**

Features / Ordering Information	B142-B143
Mounting Styles	B144
Specifications / Technical Data	B145-B146
Dimensional Data	B147-B151
Accessories / Service Kits	B152-B154



**B**

**Tie Rod Pneumatic  
Cylinders**





Features

4MA/4ML Series – 1-1/2" to 5" Bore Size

<b>B</b>	Tie Rod Pneumatic Cylinders
	Series
4MA Series	4MAU Series
ACVB Option	LPSO Option
P1D Series	P1F Series
2MNR Series	

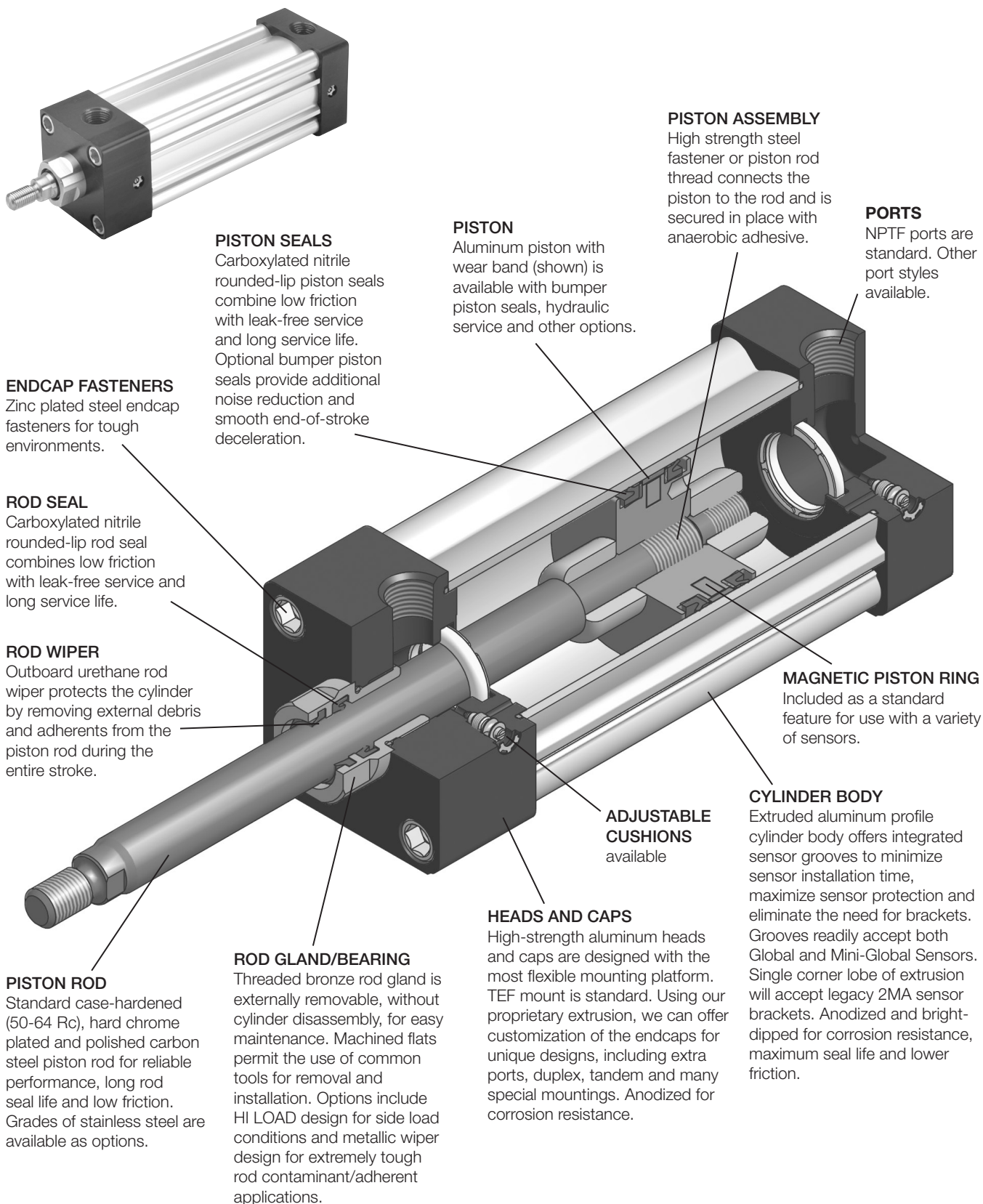

For a complete list of 4MA options, please see pages B3 and B8.



For inventory, lead times, and kit lookup, visit [www.pdnplu.com](http://www.pdnplu.com)

### Features

- Industry leading aluminum NFPA interchangeable cylinder with flexible construction
- Bore sizes – 1-1/2", 2", 2-1/2", 3-1/4", 4" and 5"
- Removable bronze alloy gland/bearing for easy maintenance
- Available in any practical stroke length
- 20 standard mounting styles available
- Extruded-profile aluminum body with integrated switch grooves
- Single rod end or double rod ends
- Cushions – standard and adjustable at both ends, optional non-cushioned
- RoHS compliant

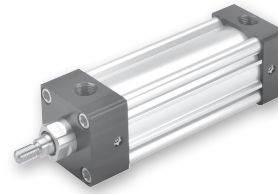

### Operating information

	4MA	4ML
Operating pressure:	250 PSIG (17 bar) maximum air service	400 PSIG (27 bar) maximum hydraulic service
Temperature range –		
Standard seals	-10°F to 165°F (-23°C to 74°C)	
Fluorocarbon seals	-10°F to 250°F (-23°C to 121°C)	
Low temperature seals	-50°F to 150°F (-46°C to 66°C)	
Filtration requirements:	40 micron, dry filtered air	Filtered hydraulic oil

### Ordering information

<b>2.00</b>	<b>J</b>	<b>4MA</b>	<b>U</b>	<b>1</b>	<b>4</b>	<b>A</b>	<b>6.000</b>
<b>Bore Size</b> 1.50 <sup>1</sup> 2.00 2.50 3.25 4.00 5.00	<b>Double Rod Cylinder</b> Specify "K" only if double rod cylinder is required.	<b>Series</b> 4MA Air Service 4ML Hydraulic Service <sup>2</sup>	<b>Ports</b> U NPTF R BSPP B BSPT T SAE	<b>Piston Rod Number</b> Specify rod code number for required diameter. <sup>8,2</sup>	<b>Special Modification</b> Specify "S" only for special modification other than rod end, and then describe modification in item notes. (Includes 4MA with Linear Position Sensor Option) <sup>7</sup>	<b>Cushion Cap End</b> Blank Non-Cushioned Cap End C Cushioned Cap End (not available for 4ML)	<b>Stroke Length</b> Specify stroke length required in inches. <sup>11</sup>
<b>Cushion Head End</b> Blank Non-Cushioned Head End C Cushioned Head End (not available for 1.50" bore with 1" rod or 4ML)	<b>Mounting Style</b> Specify mounting style code (see table on following page).	<b>Seals</b> Blank Standard (nitrile seals) V Fluorocarbon Seals <sup>4</sup> E Fluorocarbon Rod Wiper and Rod Seal Only <sup>5</sup> 4 Low Temperature Seals <sup>4</sup> M Metallic Rod Wiper, Nitrile Seals <sup>6</sup>	<b>Piston Rod Thread Style</b> 4 Small Male 8 Intermediate Male 9 Short Female 55 For Use with Split Coupler <sup>9</sup> 3 Special (and specify all dimensions required) 6 Full Male	<b>Piston Rod Thread Type</b> A Standard (UNF unified thread) W BSF British Fine M* Metric <small>* Please reference page B78.</small>	<b>Rod Material and Gland Code</b> Blank Standard Rod and Gland H Standard Rod and HI LOAD Gland <sup>13</sup> Y 17-4 PH Stainless Steel Rod and Standard Gland Z 17-4 PH Stainless Steel Rod and HI LOAD Gland <sup>13</sup> J 303 Stainless Steel Rod and Standard Gland K 303 Stainless Steel Rod and HI LOAD Gland <sup>13</sup> S 316 Stainless Steel Rod and Standard Gland T 316 Stainless Steel Rod and HI LOAD Gland <sup>13</sup>	<b>Cylinder Construction</b> Blank* Standard (extruded body, standard round lobe orientation) A* Extruded Body, Round Lobe Orientation Rotated 90 Degrees from Standard N* Extruded Body, Round Lobe Orientation Rotated 180 Degrees from Standard Z* Extruded Body, Round Lobe Orientation Rotated 270 Degrees from Standard T Aluminum Round Tube and Carbon Steel Tie Rods & Nuts	<b>Piston type<sup>2</sup></b> Blank Lipseals and Magnetic Ring (legacy) (standard for 4ML) 1 Lipseals, No Magnetic Ring (legacy) 2 Lipseals, No Magnetic Ring (aluminum piston) 3 Lipseals and Magnetic Ring (aluminum piston) (standard for 4ML) 4 Bumper Seals, No Magnetic Ring <sup>12</sup> 6 Bumper Seals and Magnetic Ring <sup>12</sup> B Lipseals, 1/4" Thick Bumpers Both Ends <sup>3</sup> H Lipseals, 1/4" Thick Bumper Head End <sup>3</sup> C Lipseals, 1/4" Thick Bumper Cap End <sup>3</sup> D Lipseals and Magnetic Ring, 1/4" Thick Bumpers Both Ends <sup>3</sup> F Lipseals and Magnetic Ring, 1/4" Thick Bumper Head End <sup>3</sup> R Lipseals and Magnetic Ring, 1/4" Thick Bumper Cap End <sup>3</sup>

\* See table on page B5. Only applies to 1-1/2" to 4" bore size.

1 Not available with Linear Position Sensor Option (LPSO).  
2 Piston Types (blank), 1, 4 and 6 not available for 4ML. Piston Types (blank) and 1 not available for oversize rod numbers 2 and 3. Seals option V only available with Piston Types 2 and 4. Seals option 4 only available with Piston Types 2 and 3.  
3 Addition of 1/4" bumper results in a 1/4" stroke loss per bumper, per end. For example, a 6" stroke cylinder with 1/4" bumpers at both ends (option B) has an effective stroke of 5-1/2".  
4 Reed and solid-state sensors only available with standard seals or options E and M. See footnote 2.  
5 Used for external chemical compatibility applications, not high temperature.  
6 If fluorocarbon seals are required with this option, please place an "S" for special in the Special Modification field and specify the "fluorocarbon seals and metallic rod wiper" in the item notes.  
7 For Linear Position Sensor Option (LPSO), please include the following information for the Special Modification item notes:  
a. Sensor part number reference LPSO section  
b. Sensor position  
c. Port position (if other than position 1)  
d. Length of stop tubing, gross stroke and net stroke (if required)  
Also, Piston Type option (blank), 3, 6, D, F or R is required.  
8 Review Piston Rod Selection Chart, please reference page A14 to determine proper piston rod diameter.  
9 For additional information regarding this style, please reference page B77. If non-standard Rod Material and Gland Code is required with this option, please place an "S" for special in Special Modification field and specify Rod Material and Gland Code in the item notes.  
11 If a stop tube is required, specify gross stroke (net stroke + stop tube) in the model number, then place an "S" for special in the Special Modification field and specify the stop tube length in the item notes.  
12 See page B79 for stroke loss on bumper seal option.  
13 HI LOAD gland not available with metallic rod wiper.

For ordering purposes, when special options or common modifications are requested, the factory will assign a sequential part number in place of the model number.



For inventory, lead times, and kit lookup, visit [www.pdnplu.com](http://www.pdnplu.com)

**4MA/4ML Mounting Styles for 1-1/2" to 5" Bore**

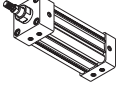
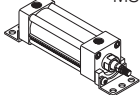
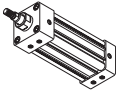
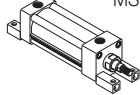
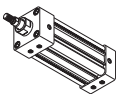
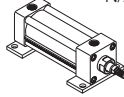
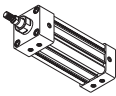
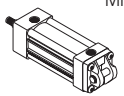
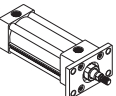
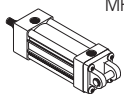
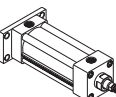
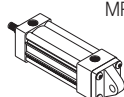
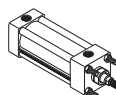
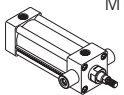
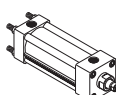
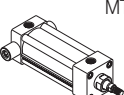
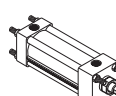
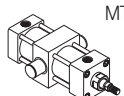
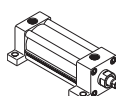
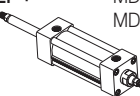
Mounting Style	NFPA Mounting	Description	Bore Size	Mounting Style	NFPA Mounting	Description	Bore Size	
<b>TEF</b> 	MX5/MS4	Sleeve Nut with Side Tap (standard mount)	4MA/4ML w/LPSO w/LPSO w/stop tube	1-1/2 - 5*	2 - 5 2 - 5	<b>CB</b> 	MS1 Side End Angle 4MA/4ML w/LPSO w/LPSO w/stop tube	1-1/2 - 5 2 - 5 2 - 5
<b>T</b> 	MX0	No Mount (same construction as TEF)	4MA/4ML w/LPSO w/LPSO w/stop tube	1-1/2 - 5 2 - 5 2 - 5	<b>G</b> 	MS7 Side End Lug 4MA/4ML w/LPSO w/LPSO w/stop tube	1-1/2 - 4* 2 - 4 2 - 4	
<b>TE</b> 	MX5	Sleeve Nut (same construction as TEF)	4MA/4ML w/LPSO w/LPSO w/stop tube	1-1/2 - 5 2 - 5 2 - 5	<b>NB</b> 	N/A Base Bar 4MA/4ML w/LPSO w/LPSO w/stop tube	1-1/2 - 4* 2 - 4 2 - 4	
<b>F</b> 	MS4	Side Tap (same construction as TEF)	4MA/4ML w/LPSO w/LPSO w/stop tube	1-1/2 - 5* 2 - 5 2 - 5	<b>BB</b> 	MP1 Cap Fixed Clevis 4MA/4ML w/LPSO w/LPSO w/stop tube	1-1/2 - 5 2 - 5** 2 - 5**	
<b>J</b> 	MF1	Head Rectangular Flange	4MA/4ML w/LPSO w/LPSO w/stop tube	1-1/2 - 5 2 - 5** 2 - 5	<b>BC</b> 	MP2 Cap Detachable Clevis 4MA/4ML w/LPSO w/LPSO w/stop tube	1-1/2 - 5 2 - 5** 2 - 5**	
<b>H</b> 	MF2	Cap Rectangular Flange	4MA/4ML w/LPSO w/LPSO w/stop tube	1-1/2 - 5 2 - 5** 2 - 5**	<b>BE</b> 	MP4 Cap Detachable Eye 4MA/4ML w/LPSO w/LPSO w/stop tube	1-1/2 - 5 2 - 5** 2 - 5**	
<b>TB</b> 	MX3	Tie Rods Extended Head End	4MA/4ML w/LPSO w/stop tube	1-1/2 - 5 2 - 5	<b>D</b> 	MT1 Head Trunnion 4MA/4ML w/LPSO w/LPSO w/stop tube	1-1/2 - 5* 2 - 5 2 - 5	
<b>TC</b> 	MX2	Tie Rods Extended Cap End	4MA/4ML	1-1/2 - 5	<b>DB</b> 	MT2 Cap Trunnion 4MA/4ML w/LPSO w/LPSO w/stop tube	1-1/2 - 5 2 - 5** 2 - 5**	
<b>TD</b> 	MX1	Tie Rods Extended Both Ends	4MA/4ML	1-1/2 - 5	<b>DD</b> 	MT4 Intermediate Trunnion 4MA/4ML	1-1/2 - 5	
<b>C</b> 	MS2	Side Lug	4MA/4ML w/LPSO w/LPSO w/stop tube	1-1/2 - 5 2 - 5 2 - 5	<b>KTEF †</b> 	MDX5/ MDS4 Double Rod End, TEF Mount 4MA/4ML w/LPSO w/LPSO w/stop tube	1-1/2 - 5 2 - 5 2 - 5	

\* Not available for 1-1/2" bore with 1" rod.

\*\* May interfere with mounting. Please provide clearance for Linear Sensor overhang (see page B73).

† Double rod end cylinders can be ordered with head mountings, i.e. KJ.

**Sensors**

See section L for sensors.



**Kits & Accessories**

See page B34.



For inventory, lead times, and kit lookup, visit [www.pdnplu.com](http://www.pdnplu.com)

**4MA Extruded Cylinder Body Sensor Slot Orientation**

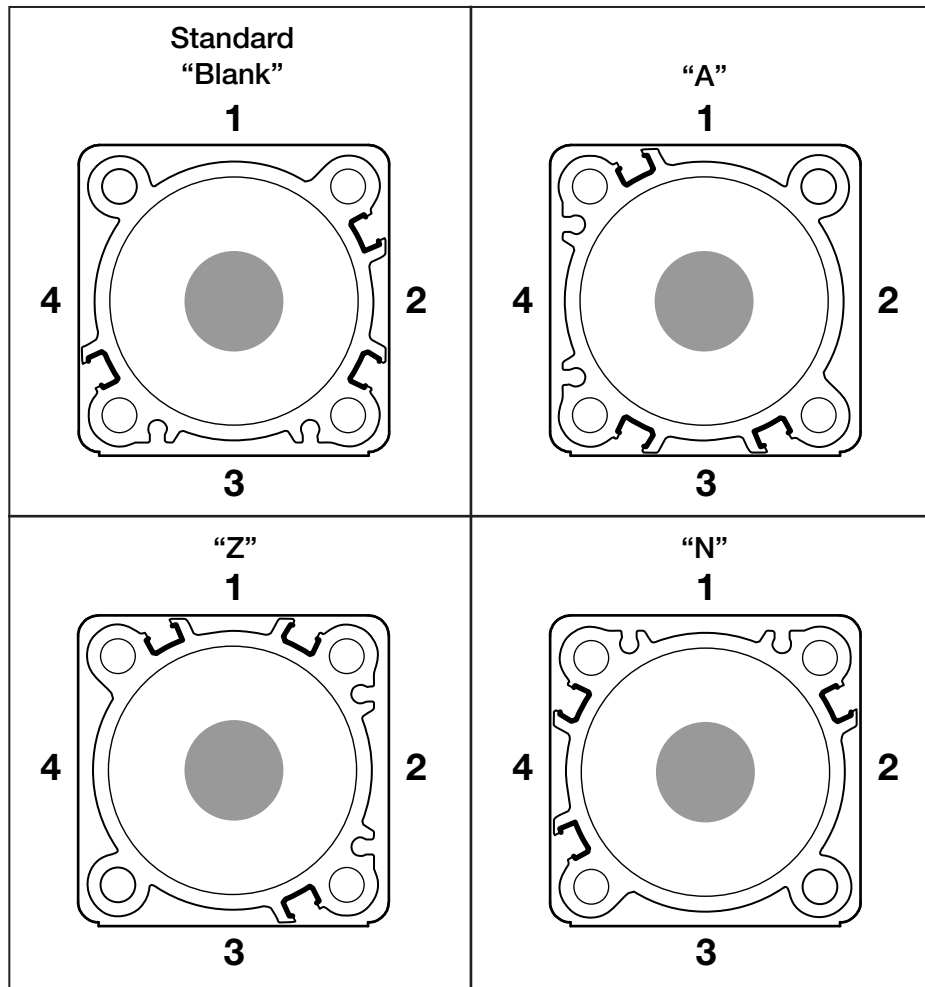

\* Only applies to 1-1/2" to 4" Bore

B
Tie Rod Pneumatic Cylinders
4MA Series
4MAJ Series
ACVB Option
LPSO Option
P1D Series
P1F Series
2MNR Series

**General Specifications**

- NFPA interchangeable
  - Bore sizes – 1-1/2", 2", 2-1/2", 3-1/4", 4" and 5"
  - Strokes – available in any practical stroke length
  - Rod diameters – 5/8", 1" and 1-3/8"
  - Rod end styles – 4 standard, specials available
  - Single rod end or double rod ends
  - Cushions – optional and adjustable at either end or both ends (N/A for 4ML Hydraulic Version)
  - Operating pressure –  
 4MA = 250 PSIG (17 bar) maximum air service  
 4ML = 400 PSIG (27 bar) maximum hydraulic service
  - Media – 4MA = dry, filtered air  
 4ML = filtered hydraulic oil
  - Temperature range –  
 -10°F to 165°F (-23°C to 74°C) standard seals  
 -10°F to 250°F (-23°C to 121°C) fluorocarbon seals option  
 -50°F to 150°F (-46°C to 66°C) low temperature seals option
  - Mounting styles – 20 standard styles
  - RoHS compliant
- For material options, including seals, piston rods and glands, please see Material Specifications on next page.

**Cylinder Weights – 4MA / 4ML Cylinders**

Bore (inch)	Rod (inch)	No Mount Single Rod 4MA/4ML		No Mount Double Rod	
		Base Wt. (lbs.)	Per Inch (lbs.)	Base Wt. (lbs.)	Per Inch (lbs.)
1-1/2	0.625	1.73	0.20	2.16	0.28
	1.00	2.99	0.35	4.34	0.58
2	0.625	2.40	0.21	3.05	0.30
	1.00	2.99	0.35	4.34	0.58
2-1/2	0.625	3.25	0.23	3.96	0.31
	1.00	4.06	0.37	5.74	0.60
3-1/4	1.00	6.45	0.42	7.65	0.64
	1.375	7.93	0.62	11.46	1.05
4	1.00	8.80	0.49	10.32	0.71
	1.375	10.29	0.69	14.37	1.12
5	1.00	13.20	0.61	15.84	0.84
	1.375	14.72	0.81	18.89	1.24

**Standard Cushion Position**

Mounting Code	Position
All except D, DB, DD	2
D, DB, DD	3

**Standard Port Sizes**

Bore	NPTF	BSPT	BSPP	SAE
1-1/2	3/8	Rc3/8	G3/8	6
2	3/8	Rc3/8	G3/8	6
2-1/2	3/8	Rc3/8	G3/8	6
3-1/4	1/2	Rc1/2	G1/2	10
4	1/2	Rc1/2	G1/2	10
5	1/2	Rc1/2	G1/2	10

**Mounting Weight Adders**

Bore (inch)	Mounting Style, Weight (lbs)							
	J, H	D, DB	BB	CB, G	DD	BE	C	BC
1-1/2	0.51	0.50	0.15	0.36	1.70	0.23	0.15	0.20
2	0.76	0.50	0.26	0.65	2.38	0.32	0.15	0.29
2-1/2	1.13	0.50	0.38	1.05	3.00	0.42	0.15	0.41
3-1/4	2.76	0.50	0.98	1.38	5.35	1.26	0.35	1.06
4	4.05	0.50	1.35	2.20	6.75	1.62	0.35	1.49
5	6.46	0.50	1.20	4.29	8.77	1.26	0.57	2.41

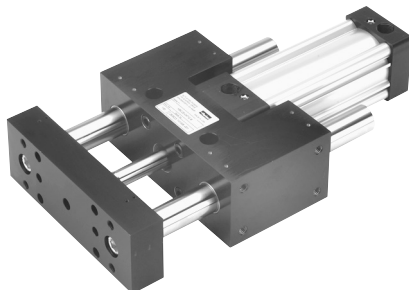

For a guided version of the 4MA or 4ML Series, please see the HB Series in Section E.

## Material Specifications

### Standard Temperatures and Applications

Head and cap	Black anodized aluminum alloy
Head and cap screws	Zinc plated steel alloy
Cylinder body	Clear anodized aluminum alloy
Piston rod	Case-hardened, chrome plated carbon steel
Rod seal	Carboxylated nitrile (Nitroxile)
Rod wiper	Molythane
Rod bearing (gland)	Bronze alloy
Piston	Aluminum alloy
Piston seals	Carboxylated nitrile (Nitroxile)
Piston bearing	Composite (for standard piston) MolyGard™ (for aluminum piston)
Magnetic ring	Plastic-bound magnetic material
Piston fastener	Piston rod for aluminum piston
O-rings	Nitrile
End seals	Nitrile
Cushion seals	Urethane
Cushion needle valves	Stainless steel
Tie-rod/studs	Blackened carbon steel 1018 (some mounts)
Tie-rod nuts	Steel alloy, SAE J995 Grade 8 (some mounts)

## Tie Rod Pneumatic Cylinders 4MA/4ML Series – 1-1/2" to 5" Bore Size

### Material and Part Changes

#### 4MA Options

High temperatures (-10°F to 250°F)	All seals and wiper are fluorocarbon Aluminum piston without magnetic ring
Low temperatures (-50°F to 150°F)	Rod seal, piston seals, o-rings and end seals are low temperature-rated nitrile

#### 4ML Hydraulic Version

Hydraulic service (general)	Cushions and bumper piston seals not available
Hydraulic service (std temp)	Polyurethane TS-2000 rod seal and nitrile piston seals (for hydraulic use)
Hydraulic service (high temp)	Fluorocarbon TS-2000 rod seal; wiper and all seals are fluorocarbon (for hydraulic use)

#### Other Standard Options

Cylinder seal options	Fluorocarbon for high temperatures or chemical compatibility Other seal options available, please consult factory
Bumper piston seal options (4MA only, N/A for 4ML)	Carboxylated nitrile (Nitroxile) for standard temperatures Fluorocarbon for high temperatures or chemical compatibility
1/4" thick bumpers option	Urethane
Piston rod material options	Case-hardened, chrome plated carbon steel (standard) 17-4 PH stainless steel, chrome plated 303 stainless steel, chrome plated (N/A for 4ML) 316 stainless steel, chrome plated (N/A for 4ML) For stainless steel without chrome plating, please consult factory
HI LOAD gland option	Composite bearing pressed into bronze alloy gland
Metallic rod scraper option	Dual high strength bronze wipers with PTFE (5/8" rod only) or fluorocarbon energizer

**B**

Tie Rod Pneumatic Cylinders

4MA Series

4MAJ Series

ACVB Option

LPSO Option

P1D Series

P1F Series

2MNR Series



For inventory, lead times, and kit lookup, visit [www.pdnplu.com](http://www.pdnplu.com)



**How to Select a 1-1/2" to 5" Bore 4MA Cylinder**

Parker cylinders are available based on air or hydraulic operating pressure. The many styles, sizes and optional features available assure that your application requirements are precisely met. To select a cylinder, follow these simple steps:

- Step 1 - **Determine the correct cylinder bore size** necessary to achieve required force using the available operating pressure.
- Step 2 - **Determine the series cylinder to use**, based on operating pressure.
- Step 3 - **Turn to the appropriate cylinder selection section.** Select the mounting style that fits your installation needs. Determine the bore and rod sizes available for the model you select. Then complete model selection.
  - Choose a rod end style and the desired rod end accessories.
  - Size the cylinder to meet your application requirements.
- Step 4 - **Consider the following conditions** which may require further modifications to the cylinder you have selected.

**Application Condition**

**Check the Following**

Quick Starts or Stops	Confirm that determined thrust is sufficient to accelerate or decelerate cylinder and load within prescribed distance. Optional cushions should be used to reduce shock during deceleration, check that peak pressures will be within tolerable limits.
Long Push Stroke	Check whether stop tube is required to prevent excessive bearing loads and wear.
High-column Loading Long Push Stroke	Determine if standard size piston rod is strong enough to accommodate intended load. See Application Engineering section for recommendations.
Long Horizontal Stroke	Determine if standard size piston rod is strong enough to accommodate intended load.
High Operating Temperatures	For temperatures between 165°F and 250°F use 4MA or 4ML cylinder with high temperature seals.

**General Options and Modifications:**

- Adjustable Cushions
- Non-Magnetic Piston (magnetic ring standard)
- Piston Bumper Seals
- Piston Bumpers (1/4" thick)
- Port and Adjustable Cushion Relocation
- Port Thread Styles
- Multiple Ports
- Special Heads, Caps, Pistons and Mounts
- Double Rod End
- Oversize Rod Diameters
- Rod End Modifications
- Rod Materials (grades of stainless steel)
- Fluorocarbon Rod Wiper and Rod Seal only
- Fluorocarbon Seals (all cylinder seals)
- Metallic Rod Wiper
- HI LOAD Gland Assembly
- Stop Tube
- Mixed Mountings
- Round Tube and Tie Rod Construction
- Stainless Steel Fasteners/Tie Rods
- Shock Absorber on Cap End
- NuCushion Bumpers
- Hydro-Check unit for smooth hydraulic control
- Air Cylinder/Valve Combination (ACVB)
- Adjustable Point Sensors (order separately)
- Continuous Linear Position Sensing (LPSO)
- High Temperature Service (to 250°F)
- Low Temperature Service (to -50°F)
- Hydraulic Service (4ML) (400 PSIG)
- Rod lock version (see 4MAJ)

**B**  
Tie Rod Pneumatic Cylinders

4MA Series

4MAJ Series

ACVB Option

LPSO Option

P1D Series

P1F Series

2MNR Series



For inventory, lead times, and kit lookup, visit [www.pdnplu.com](http://www.pdnplu.com)



**Single Rod**  
**(Styles TEF, T, TE and F)**

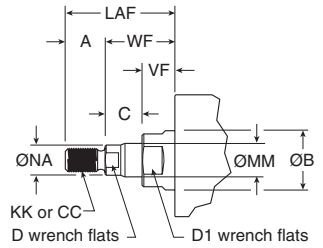
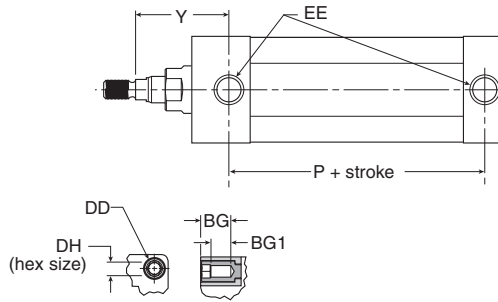
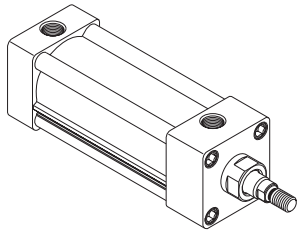

For dimensions of all standard rod end styles, see next page.

1-1/2" bore with 1" rod is TE mount, F mount not available.  
 1-1/2" bore with 1" rod cannot have a cushion at head end.

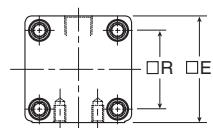
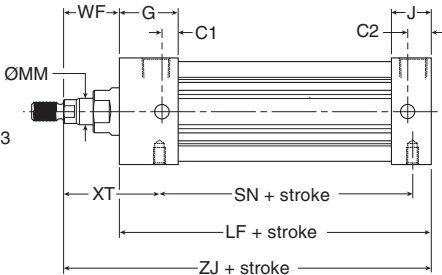
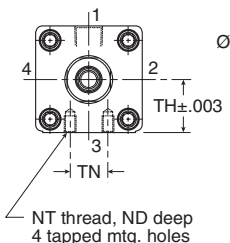

**Styles TEF, T, TE and F**

Bore Size	Rod no.	Thread				Style 4													EE (NPTF)
		Rod Dia. MM	Style 8 CC	Style 9 & 8 KK	Style 6	A	AA	B	BG	BG1	C	C1	C2	D	D1	DD	DH	E	
1-1/2	1	5/8	1/2 - 20	7/16 - 20	5/8 - 18	0.750	2.020	1.124	0.562	0.374	0.385	1.000	0.500	1/2	1	1/4 - 28	1/4	2.000	3/8
	2*	1	7/8 - 14	3/4 - 16	1 - 14	1.125	2.020	1.499	0.562	0.374	0.510	-	0.500	7/8	1-3/8	1/4 - 28	1/4	2.000	3/8
2	1	5/8	1/2 - 20	7/16 - 20	5/8 - 18	0.750	2.600	1.124	0.562	0.362	0.385	1.000	0.562	1/2	1	5/16 - 24	5/16	2.500	3/8
	3	1	7/8 - 14	3/4 - 16	1 - 14	1.125	2.600	1.499	0.562	0.362	0.510	1.000	0.562	7/8	1-3/8	5/16 - 24	5/16	2.500	3/8
2-1/2	1	5/8	1/2 - 20	7/16 - 20	5/8 - 18	0.750	3.100	1.124	0.562	0.362	0.385	1.000	0.594	1/2	1	5/16 - 24	5/16	3.000	3/8
	3	1	7/8 - 14	3/4 - 16	1 - 14	1.125	3.100	1.499	0.562	0.362	0.510	1.000	0.594	7/8	1-3/8	5/16 - 24	5/16	3.000	3/8
3-1/4	1	1	7/8 - 14	3/4 - 16	1 - 14	1.125	3.900	1.499	0.700	0.500	0.510	1.188	0.719	7/8	1-3/8	3/8 - 24	3/8	3.750	1/2
	3	1-3/8	1-1/4 - 12	1 - 14	1-3/8 - 14	1.625	3.900	1.999	0.700	0.500	0.635	1.188	0.719	1-1/8	1-7/8	3/8 - 24	3/8	3.750	1/2
4	1	1	7/8 - 14	3/4 - 16	1 - 14	1.125	4.700	1.499	0.700	0.500	0.510	1.188	0.719	7/8	1-3/8	3/8 - 24	3/8	4.500	1/2
	3	1 3/8	1-1/4 - 12	1 - 14	1-3/8 - 14	1.625	4.700	1.999	0.700	0.500	0.635	1.188	0.719	1-1/8	1-7/8	3/8 - 24	3/8	4.500	1/2
5	1	1	7/8 - 14	3/4 - 16	1 - 14	1.125	5.800	1.499	0.781	0.531	0.510	1.188	0.813	7/8	1-3/8	1/2 - 20	1/2	5.500	1/2
	3	1 3/8	1-1/4 - 12	1 - 14	1-3/8 - 14	1.625	5.800	1.999	0.781	0.531	0.635	1.188	0.813	1-1/8	1-7/8	1/2 - 20	1/2	5.500	1/2

Bore Size	Rod no.	Rod Dia. MM	Style 4													Add Stroke			
			G	J	LAF	NA	ND	NT	R	TH	TN	VF	WF	XT	Y	LF	P	SN	ZJ
1-1/2	1	5/8	1.438	0.938	1.750	0.563	0.375	1/4 - 20	1.430	0.993	0.625	0.615	1.000	1.938	1.875	3.625	2.313	2.250	4.625
	2*	1	1.438	0.938	2.500	0.938	-	-	1.430	0.993	-	0.865	1.375	-	2.250	3.625	2.313	-	5.000
2	1	5/8	1.375	0.937	1.750	0.563	0.438	5/16 - 18	1.840	1.243	0.875	0.615	1.000	1.938	1.875	3.625	2.313	2.250	4.625
	3	1	1.375	0.937	2.500	0.938	0.375	5/16 - 18	1.840	1.243	0.875	0.865	1.375	2.313	2.250	3.625	2.313	2.250	5.000
2-1/2	1	5/8	1.344	0.938	1.750	0.563	0.625	3/8 - 16	2.190	1.493	1.250	0.615	1.000	1.938	1.938	3.750	2.375	2.375	4.750
	3	1	1.344	0.938	2.500	0.938	0.625	3/8 - 16	2.190	1.493	1.250	0.865	1.375	2.313	2.313	3.750	2.375	2.375	5.125
3-1/4	1	1	1.594	1.125	2.500	0.938	0.750	1/2 - 13	2.760	1.868	1.500	0.865	1.375	2.438	2.438	4.250	2.625	2.625	5.625
	3	1-3/8	1.594	1.125	3.250	1.313	0.750	1/2 - 13	2.760	1.868	1.500	0.990	1.625	2.688	2.688	4.250	2.625	2.625	5.875
4	1	1	1.594	1.125	2.500	0.938	0.750	1/2 - 13	3.320	2.243	2.063	0.865	1.375	2.438	2.438	4.250	2.625	2.625	5.625
	3	1-3/8	1.594	1.125	3.250	1.313	0.750	1/2 - 13	3.320	2.243	2.063	0.990	1.625	2.688	2.688	4.250	2.625	2.625	5.875
5	1	1	1.594	1.219	2.500	0.938	0.938	5/8 - 11	4.100	2.743	2.688	0.865	1.375	2.438	2.438	4.500	2.875	2.875	5.875
	3	1 3/8	1.594	1.219	3.250	1.313	0.938	5/8 - 11	4.100	2.743	2.688	0.990	1.625	2.688	2.688	4.500	2.875	2.875	6.125

\* NOTE - 1-1/2" bore with 1" rod is TE mount, F mount not available.  
 1-1/2" bore with 1" rod cannot have a cushion at head end.

**B**

Tie Rod Pneumatic Cylinders

4MA Series

4MAJ Series

ACVB Option

LPSO Option

P1D Series

P1F Series

2MNR Series



For inventory, lead times, and kit lookup, visit [www.pdnplu.com](http://www.pdnplu.com)

**Thread Style Rod End**

**Thread Style 4**  
(NFPA Style SM)  
Small Male

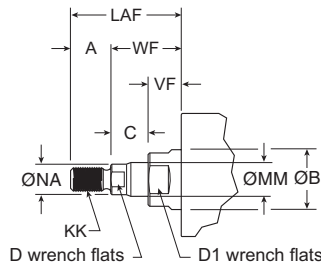

**Thread Style 8**  
(NFPA Style IM)  
Intermediate Male

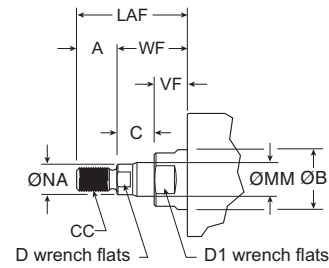

**Thread Style 9**  
(NFPA Style SF)  
Short Female

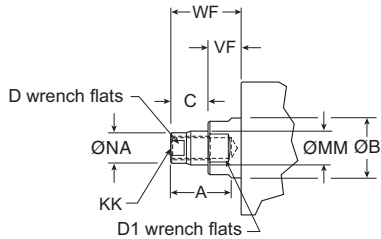

**Thread Style 55**

For use with Split Coupler  
(please reference page B77 for more information)

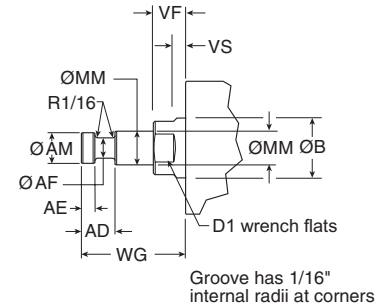

**Thread Style 3 - "Special Thread"**

Special threads, rod extensions, rod eyes, blanks, etc. are also available.  
To order, specify "Style 3" and give desired dimensions for KK or CC, A and W or WF.  
If otherwise special, please supply dimensioned sketch.

**Rod End Dimensions**

Bore Size	Rod no.	Rod Dia. MM	Thread																
			Style 8 CC	Style 4 & 9 KK	Style 6	A	AD	AE	AF	AM	B	C	D	D1	LAF	NA	VF	WF	WG
1-1/2	1	5/8	1/2 - 20	7/16 - 20	5/8 - 18	0.750	0.625	0.250	0.375	0.570	1.124	0.385	1/2	1	1.750	0.563	0.615	1.000	1.750
	2	1	7/8 - 14	3/4 - 16	1 - 14	1.125	0.938	0.375	0.688	0.950	1.499	0.510	7/8	1-3/8	2.500	0.938	0.865	1.375	2.375
2	1	5/8	1/2 - 20	7/16 - 20	5/8 - 18	0.750	0.625	0.250	0.375	0.570	1.124	0.385	1/2	1	1.750	0.563	0.615	1.000	1.750
	3	1	7/8 - 14	3/4 - 16	1 - 14	1.125	0.938	0.375	0.688	0.950	1.499	0.510	7/8	1-3/8	2.500	0.938	0.865	1.375	2.375
2-1/2	1	5/8	1/2 - 20	7/16 - 20	5/8 - 18	0.750	0.625	0.250	0.375	0.570	1.124	0.385	1/2	1	1.750	0.563	0.615	1.000	1.750
	3	1	7/8 - 14	3/4 - 16	1 - 14	1.125	0.938	0.375	0.688	0.950	1.499	0.510	7/8	1-3/8	2.500	0.938	0.865	1.375	2.375
3-1/4	1	1	7/8 - 14	3/4 - 16	1 - 14	1.125	0.938	0.375	0.688	0.950	1.499	0.510	7/8	1-3/8	2.500	0.938	0.865	1.375	2.375
	3	1-3/8	1-1/4 - 12	1 - 14	1 - 3/8 - 14	1.625	1.063	0.375	0.875	1.320	1.999	0.635	1-1/8	1-7/8	3.250	1.313	0.990	1.625	2.750
4	1	1	7/8 - 14	3/4 - 16	1 - 14	1.125	0.938	0.375	0.688	0.950	1.499	0.510	7/8	1-3/8	2.500	0.938	0.865	1.375	2.375
	3	1-3/8	1-1/4 - 12	1 - 14	1 - 3/8 - 14	1.625	1.063	0.375	0.875	1.320	1.999	0.635	1-1/8	1-7/8	3.250	1.313	0.990	1.625	2.750
5	1	1	7/8 - 14	3/4 - 16	1 - 14	1.125	0.938	0.375	0.688	0.950	1.499	0.510	7/8	1-3/8	2.500	0.938	0.865	1.375	2.375
	3	1-3/8	1-1/4 - 12	1 - 14	1 - 3/8 - 14	1.625	1.063	0.375	0.875	1.320	1.999	0.635	1-1/8	1-7/8	3.250	1.313	0.990	1.625	2.750



For inventory, lead times, and kit lookup, visit [www.pdnplu.com](http://www.pdnplu.com)

To determine dimensions for a double rod end cylinder, first refer to the desired single rod end mounting style cylinder shown in this catalog section. After selecting the necessary dimensions from that drawing, return to this page and supplement the single rod end dimensions with those shown in the drawings and dimension table below. Note that double rod end cylinders have a head dimension G at both ends, and

that LG replaces LF, P<sub>k</sub> replaces P, etc. The double rod end dimensions differ from, or are in addition to, those for single rod cylinders.

When a double rod end cylinder has two different rod ends, please clearly state which rod end is to be available at which head end.

**K-type for 1-1/2" to 5" Bore**

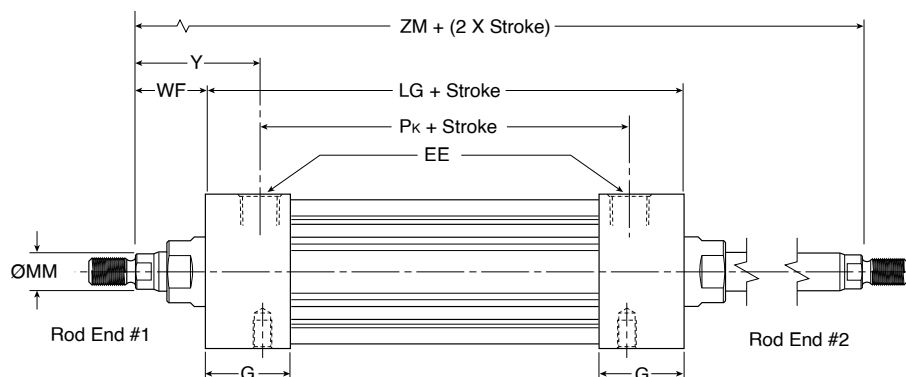

Mounting styles for single rod models	Corresponding mounting styles for double rod models
C	KC
CB	KCB
D	KD
DD	KDD
F	KF
G	KG
J	KJ
NB	KNB
T	KT
TB	KTB
TD	KTD
TE	KTE
TEF	KTEF

**K-type Dimensions**

Bore Size	Rod no.	Rod Dia. MM	Rod Dia. EE (NPTF)	G	WF	Y	Add Stroke						Add 2X Stroke ZM		
							LG	Pk	SAk	XAk	SSk	SNk		SEk	XEk
1-1/2	1	5/8	3/8	1.438	1.000	1.875	4.125	2.375	6.125	6.125	3.375	2.250	6.375	6.250	6.125
	2	1	3/8	1.438	1.375	2.250	4.125	2.375	6.500	6.500	3.375	-	-	-	5.760
2	1	5/8	3/8	1.375	1.000	1.875	4.125	2.375	6.125	6.125	3.375	2.250	6.750	6.438	6.125
	3	1	3/8	1.375	1.375	2.250	4.125	2.375	6.125	6.500	3.375	2.250	6.750	6.813	6.875
2-1/2	1	5/8	3/8	1.344	1.000	1.938	4.250	2.375	6.250	6.250	3.500	2.375	7.125	6.688	6.250
	3	1	3/8	1.344	1.375	2.313	4.250	2.375	6.250	6.625	3.500	2.375	7.125	7.063	7.000
3-1/4	1	1	1/2	1.594	1.375	2.438	4.750	2.625	7.250	7.375	3.750	2.625	7.750	7.625	7.500
	3	1-3/8	1/2	1.594	1.625	2.688	4.750	2.625	7.250	7.625	3.750	2.625	7.750	7.875	8.000
4	1	1	1/2	1.594	1.375	2.438	4.750	2.625	7.250	7.375	3.750	2.625	8.000	7.750	7.500
	3	1-3/8	1/2	1.594	1.625	2.688	4.750	2.625	7.250	7.625	3.750	2.625	8.000	8.000	8.000
5	1	1	1/2	1.594	1.375	2.438	4.938	2.813	7.688	7.688	3.563	2.813	-	-	7.688
	3	1-3/8	1/2	1.594	1.625	2.688	4.938	2.813	7.688	7.938	3.563	2.813	-	-	8.188
Replaces Dimension							LF	P	SA	XA	SS	SN	SE	XE	-
On Single Rod Mounting Styles							All Styles	All Styles	CB	CB	C	TEF, F	G	G	All

<b>B</b>
Tie Rod Pneumatic Cylinders
4MA Series
4MAJ Series
ACVB Option
LPSO Option
P1D Series
P1F Series
2MNR Series



**Head Rectangular Flange**

Style J  
 (NFPA MF1)

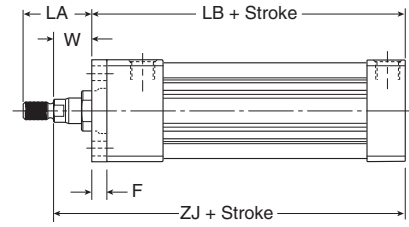
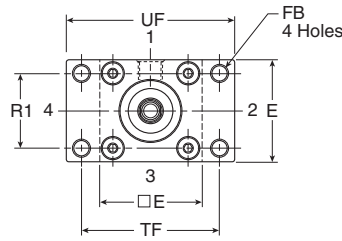
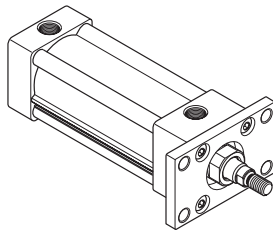

**Note:** Style J has a W dimension instead of WF and a LA dimension instead of LAF because of the flange installation. Please use dimensions W and LA regarding rod ends only for Style J.

For reference,  $WF = W + F$  and  $LA = W + A$ .

**Cap Rectangular Flange**

Style H  
 (NFPA MF2)

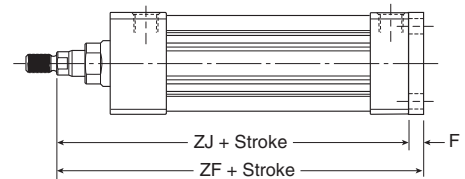
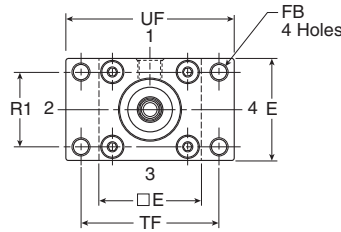
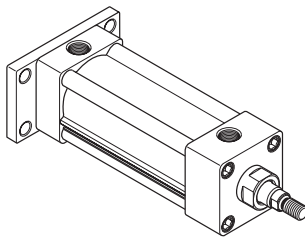

**Styles J and H Dimensions**

Bore Size	Rod no.	Rod Dia. MM	A	E	F	FB	LA	R1	TF	UF	W	Add Stroke		
												LB	ZF	ZJ
1-1/2	1	5/8	0.750	2.000	0.375	0.313	1.375	1.430	2.750	3.375	0.625	4.000	5.000	4.625
	2	1	1.125	2.000	0.375	0.313	2.125	1.430	2.750	3.375	1.000	4.000	5.375	5.000
2	1	5/8	0.750	2.500	0.375	0.375	1.375	1.840	3.375	4.125	0.625	4.000	5.000	4.625
	3	1	1.125	2.500	0.375	0.375	2.125	1.840	3.375	4.125	1.000	4.000	5.375	5.000
2-1/2	1	5/8	0.750	3.000	0.375	0.375	1.375	2.190	3.875	4.625	0.625	4.125	5.125	4.750
	3	1	1.125	3.000	0.375	0.375	2.125	2.190	3.875	4.625	1.000	4.125	5.500	5.125
3-1/4	1	1	1.125	3.750	0.625	0.438	1.875	2.760	4.688	5.500	0.750	4.875	6.250	5.625
	3	1-3/8	1.625	3.750	0.625	0.438	2.625	2.760	4.688	5.500	1.000	4.875	6.500	5.875
4	1	1	1.125	4.500	0.625	0.438	1.875	3.320	5.438	6.250	0.750	4.875	6.250	5.625
	3	1-3/8	1.625	4.500	0.625	0.438	2.625	3.320	5.438	6.250	1.000	4.875	6.500	5.875
5	1	1	1.125	5.500	0.625	0.563	1.875	4.100	6.625	7.625	0.750	5.125	6.500	5.875
	3	1-3/8	1.625	5.500	0.625	0.563	2.625	4.100	6.625	7.625	1.000	5.125	6.750	6.125

**B**  
 Tie Rod Pneumatic Cylinders

4MA Series

4MAJ Series

ACVB Option

LPSO Option

P1D Series

P1F Series

2MNR Series

**Tie Rods Ext. Head End**

Style TB  
 (NFPA MX3)

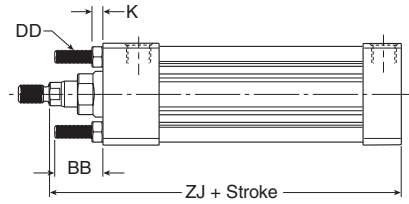
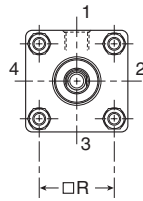
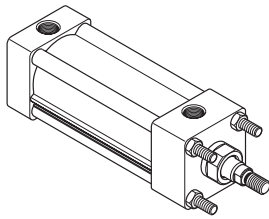

**Tie Rods Ext. Cap End**

Style TC  
 (NFPA MX2)

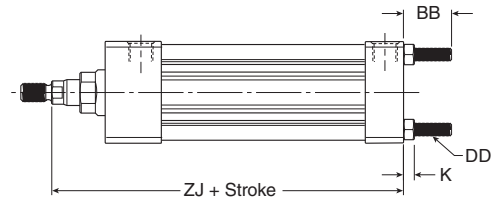
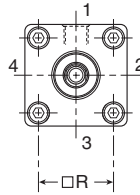
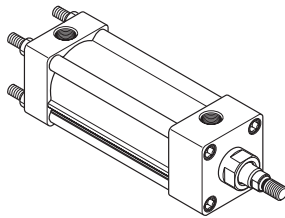

**Tie Rods Ext. Both Ends**

Style TD  
 (NFPA MX1)

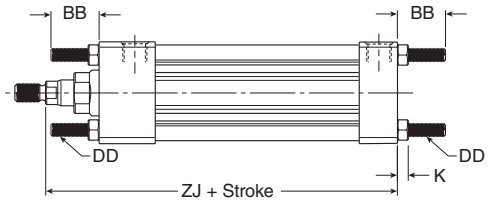
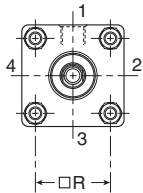
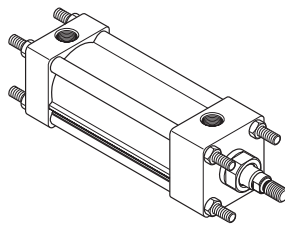

**Styles TB, TC and TD Dimensions**

Bore Size	Rod no.	Rod Dia. MM	BB	DD	E	K	R	Add Stroke	
								ZJ	
1-1/2	1	5/8	1.000	1/4 - 28	2.000	0.250	1.430	4.625	
	2	1	1.000	1/4 - 28	2.000	0.250	1.430	5.000	
2	1	5/8	1.125	5/16 - 24	2.500	0.313	1.840	4.625	
	3	1	1.125	5/16 - 24	2.500	0.313	1.840	5.000	
2-1/2	1	5/8	1.125	5/16 - 24	3.000	0.313	2.190	4.750	
	3	1	1.125	5/16 - 24	3.000	0.313	2.190	5.125	
3-1/4	1	1	1.375	3/8 - 24	3.750	0.375	2.760	5.625	
	3	1-3/8	1.375	3/8 - 24	3.750	0.375	2.760	5.875	
4	1	1	1.375	3/8 - 24	4.500	0.375	3.320	5.625	
	3	1-3/8	1.375	3/8 - 24	4.500	0.375	3.320	5.875	
5	1	1	1.813	1/2 - 20	5.500	0.438	4.100	5.875	
	3	1-3/8	1.813	1/2 - 20	5.500	0.438	4.100	6.125	

**B**

Tie Rod Pneumatic Cylinders

4MA Series

4MAJ Series

ACVB Option

LPSO Option

P1D Series

P1F Series

2MNR Series



For inventory, lead times, and kit lookup, visit [www.pdnplu.com](http://www.pdnplu.com)

**Side Lug**  
 Style C for  
 (NFPA MS2)

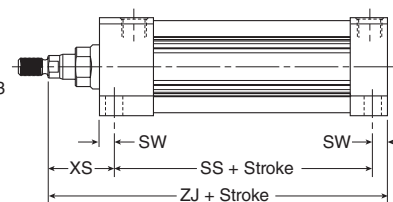
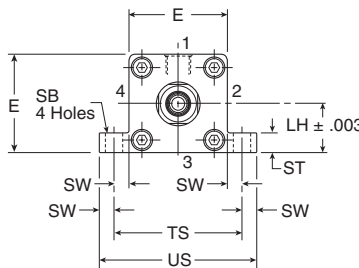
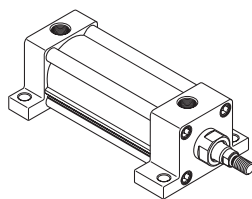

**Style C Dimensions**

Bore Size	Rod no.	Rod Dia. MM	E	LH	SB	ST	ST1	ST2	SW	SW1	TS	US	Add Stroke		
													XS	SS	ZJ
1-1/2	1	5/8	2.000	0.993	0.438	0.500	1.000	0.120	0.375	0.495	2.750	3.500	1.375	2.875	4.625
	2	1	2.000	0.993	0.438	0.500	1.000	0.120	0.375	0.495	2.750	3.500	1.750	2.875	5.000
2	1	5/8	2.500	1.243	0.438	0.500	1.250	0.120	0.375	0.495	3.250	4.000	1.375	2.875	4.625
	3	1	2.500	1.243	0.438	0.500	1.250	0.120	0.375	0.495	3.250	4.000	1.750	2.875	5.000
2-1/2	1	5/8	3.000	1.493	0.438	0.500	1.343	0.120	0.375	0.495	3.750	4.500	1.375	3.000	4.750
	3	1	3.000	1.493	0.438	0.500	1.343	0.120	0.375	0.495	3.750	4.500	1.750	3.000	5.125
3-1/4	1	1	3.750	1.868	0.563	0.750	1.500	0.188	0.500	0.688	4.750	5.750	1.875	3.250	5.625
	3	1-3/8	3.750	1.868	0.563	0.750	1.500	0.188	0.500	0.688	4.750	5.750	2.125	3.250	5.875
4	1	1	4.500	2.243	0.563	0.750	1.500	0.188	0.500	0.688	5.500	6.500	1.875	3.250	5.625
	3	1-3/8	4.500	2.243	0.563	0.750	1.500	0.188	0.500	0.688	5.500	6.500	2.125	3.250	5.875
5	1	1	5.500	2.743	0.813	1.000	1.500	0.250	0.688	0.938	6.875	8.250	2.063	3.125	5.875
	3	1-3/8	5.500	2.743	0.813	1.000	1.500	0.250	0.688	0.938	6.875	8.250	2.313	3.125	6.125

**Side End Angle**

\* Style CB  
 (NFPA MS1)

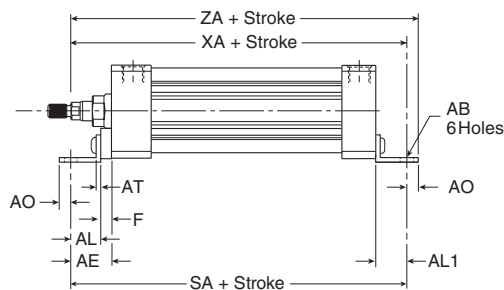
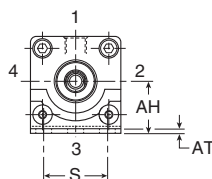
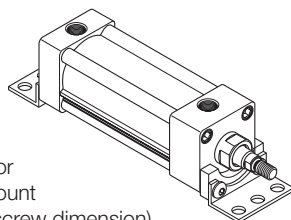

\* Maximum recommended pressure for this mount is 150 PSIG.

**Style CB Dimensions**

Bore Size	Rod no.	Rod Dia. MM	AB	AE	AH	AL	AL1	AO	AT	E	F	S	Add Stroke		
													SA	XA	ZA
1-1/2	1	5/8	0.438	1.375	1.188	1.000	1.000	0.375	0.125	2.000	0.375	1.250	6.000	5.625	6.000
	2	1	0.438	1.375	1.188	1.000	1.000	0.375	0.125	2.000	0.375	1.250	6.000	6.000	6.375
2	1	5/8	0.438	1.375	1.438	1.000	1.000	0.375	0.125	2.500	0.375	1.750	6.000	5.625	6.000
	3	1	0.438	1.375	1.438	1.000	1.000	0.375	0.125	2.500	0.375	1.750	6.000	6.000	6.375
2-1/2	1	5/8	0.438	1.375	1.625	1.000	1.000	0.375	0.125	3.000	0.375	2.250	6.125	5.750	6.125
	3	1	0.438	1.375	1.625	1.000	1.000	0.375	0.125	3.000	0.375	2.250	6.125	6.125	6.500
3-1/4	1	1	0.563	1.875	1.938	1.250	1.250	0.500	0.125	3.750	0.625	2.750	7.375	6.875	7.375
	3	1-3/8	0.563	1.875	1.938	1.250	1.250	0.500	0.125	3.750	0.625	2.750	7.375	7.125	7.625
4	1	1	0.563	-	2.250	1.875	1.250	0.500	0.125	4.500	-	3.500	7.375	6.875	7.375
	3	1-3/8	0.563	-	2.250	1.875	1.250	0.500	0.125	4.500	-	3.500	7.375	7.125	7.625
5	1	1	0.688	2.000	2.750	1.375	1.375	0.625	0.188	5.500	0.625	4.250	7.875	7.250	7.875
	3	1-3/8	0.688	2.000	2.750	1.375	1.375	0.625	0.188	5.500	0.625	4.250	7.875	7.500	8.125



For inventory, lead times, and kit lookup, visit [www.pdnplu.com](http://www.pdnplu.com)

**Side End Lug**

Style G  
 (NFPA MS7)

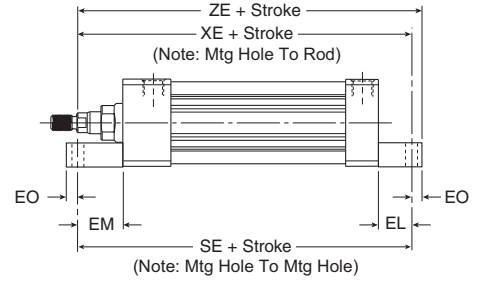
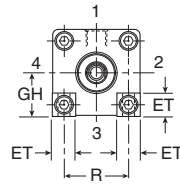
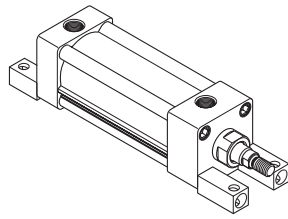

**Style G Dimensions**

Bore Size	Rod no.	Rod Dia. MM	E	EB	EL	EM	EO	ET	GH	R	Add Stroke		
											SE	XE	ZE
1-1/2	1	5/8	2.000	0.281	0.750	1.125	0.250	0.563	0.993	1.430	5.500	5.375	5.625
	2	1	-	-	-	-	-	-	-	-	-	-	-
2	1	5/8	2.500	0.344	0.938	1.313	0.313	0.688	1.243	1.840	5.875	5.563	5.875
	3	1	2.500	0.344	0.938	1.313	0.313	0.688	1.243	1.840	5.875	5.938	6.250
2-1/2	1	5/8	3.000	0.344	1.063	1.438	0.313	0.813	1.493	2.190	6.250	5.813	6.125
	3	1	3.000	0.344	1.063	1.438	0.313	0.813	1.493	2.190	6.250	6.188	6.500
3-1/4	1	1	3.750	0.406	0.875	1.500	0.375	1.000	1.868	2.760	6.625	6.500	6.875
	3	1-3/8	3.750	0.406	0.875	1.500	0.375	1.000	1.868	2.760	6.625	6.750	7.125
4	1	1	4.500	0.406	1.000	1.625	0.375	1.188	2.243	3.320	6.875	6.625	7.000
	3	1-3/8	4.500	0.406	1.000	1.625	0.375	1.188	2.243	3.320	6.875	6.875	7.250

**Base Bar Mount**

Style NB for 4MA

**Note:** Fasteners for NB base bar mount have been applied with removable thread locking compound and torqued to bottom of endcaps.

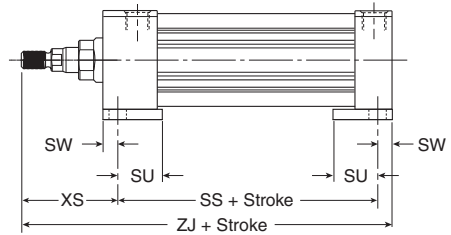
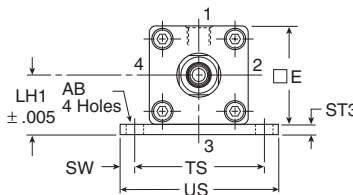
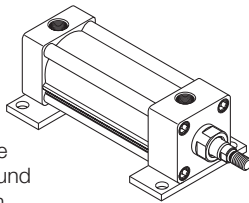

**Style NB Dimensions**

Bore Size	Rod no.	Rod Dia. MM	AB	E	LH1	ST3	SU	SW	TS	US	XS	Add Stroke	
												SS	ZJ
1-1/2	1	5/8	0.438	2.000	1.243	0.250	1.125	0.375	2.750	3.500	1.375	2.875	4.625
	2	1	-	-	-	-	-	-	-	-	-	-	-
2	1	5/8	0.438	2.500	1.493	0.250	1.125	0.375	3.250	4.000	1.375	2.875	4.625
	3	1	0.438	2.500	1.493	0.250	1.125	0.375	3.250	4.000	1.750	2.875	5.000
2-1/2	1	5/8	0.438	3.000	1.868	0.375	1.125	0.375	3.750	4.500	1.375	3.000	4.750
	3	1	0.438	3.000	1.868	0.375	1.125	0.375	3.750	4.500	1.750	3.000	5.125
3-1/4	1	1	0.563	3.750	2.368	0.500	1.250	0.500	4.750	5.750	1.875	3.250	5.625
	3	1-3/8	0.563	3.750	2.368	0.500	1.250	0.500	4.750	5.750	2.125	3.250	5.875
4	1	1	0.563	4.500	2.743	0.500	1.250	0.500	5.500	6.500	1.875	3.250	5.625
	3	1-3/8	0.563	4.500	2.743	0.500	1.250	0.500	5.500	6.500	2.125	3.250	5.875

**B**

Tie Rod Pneumatic Cylinders

4MA Series

4MAJ Series

ACVB Option

LPSO Option

P1D Series

P1F Series

2MNR Series



For inventory, lead times, and kit lookup, visit [www.pdnplu.com](http://www.pdnplu.com)

B15

**Parker Hannifin Corporation**  
 Pneumatic Division  
 Wadsworth, Ohio  
[www.parker.com/pneumatics](http://www.parker.com/pneumatics)



**Cap Fixed Clevis**

Style BB  
 (NFPA MP1)

**Note:** For maximum swivel angle of BB mount with rear mounting plate, see cylinder accessories

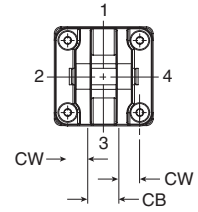
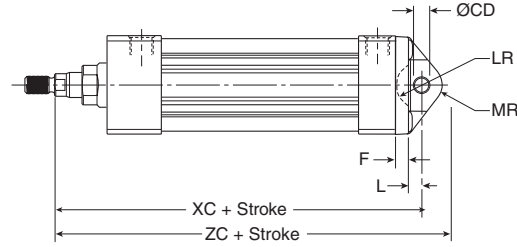
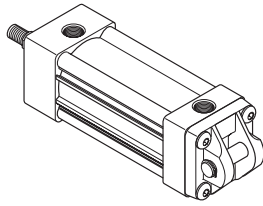

**Cap Detachable Clevis**

Style BC  
 (NFPA MP2)

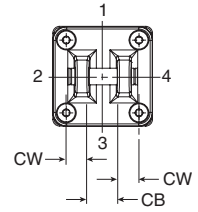
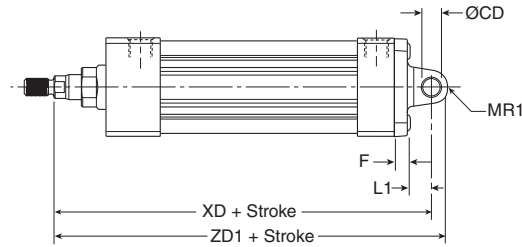
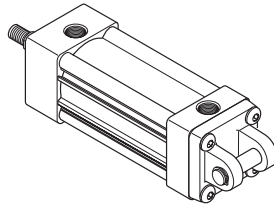

**Cap Detachable Eye**

Style BE  
 (NFPA MP4)

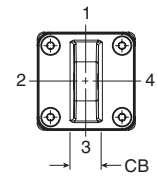
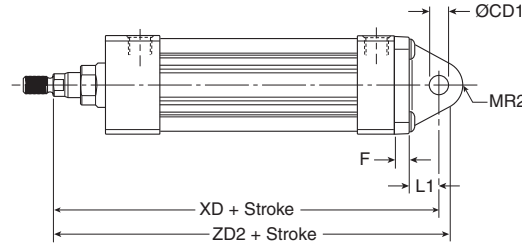
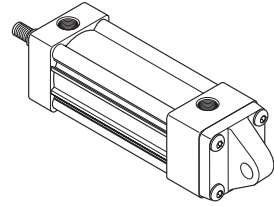

**Styles BB, BC and BE Dimensions**

Bore Size	Rod no.	Rod Dia. MM	CB	Rod Dia.		CW	E*	F	L	LR	L1	MR	MR1	MR2	Add Stroke				
				+0.000 -0.002	+0.002 +0.004										CD	CD1	XC	XD	ZC
1-1/2	1	5/8	0.750	0.501	0.500	0.500	2.000	0.375	0.375	0.750	0.750	0.625	0.500	0.625	5.375	5.750	6.000	6.250	6.375
	2	1	0.750	0.501	0.500	0.500	2.000	0.375	0.375	0.750	0.750	0.625	0.500	0.625	5.750	6.125	6.375	6.625	6.750
2	1	5/8	0.750	0.501	0.500	0.500	2.500	0.375	0.375	0.750	0.750	0.625	0.500	0.625	5.375	5.750	6.000	6.250	6.375
	3	1	0.750	0.501	0.500	0.500	2.500	0.375	0.375	0.750	0.750	0.625	0.500	0.625	5.750	6.125	6.375	6.625	6.750
2-1/2	1	5/8	0.750	0.501	0.500	0.500	3.000	0.375	0.375	0.750	0.750	0.625	0.500	0.688	5.500	5.875	6.125	6.375	6.563
	3	1	0.750	0.501	0.500	0.500	3.000	0.375	0.375	0.750	0.750	0.625	0.500	0.688	5.875	6.250	6.500	6.750	6.313
3-1/4	1	1	1.250	0.751	0.750	0.625	3.750	0.625	0.625	1.000	1.250	0.938	0.750	0.875	6.875	7.500	7.813	8.250	8.375
	3	1-3/8	1.250	0.751	0.750	0.625	3.750	0.625	0.625	1.000	1.250	0.938	0.750	0.875	7.125	7.750	8.063	8.500	8.625
4	1	1	1.250	0.751	0.750	0.625	4.500	0.625	0.625	1.000	1.250	0.938	0.750	0.875	6.875	7.500	7.813	8.250	8.375
	3	1-3/8	1.250	0.751	0.750	0.625	4.500	0.625	0.625	1.000	1.250	0.938	0.750	0.875	7.125	7.750	8.063	8.500	8.625
5	1	1	1.250	0.751	0.750	0.625	5.500	0.625	0.625	1.000	1.250	0.938	0.750	0.875	7.125	7.750	8.063	8.500	8.625
	3	1-3/8	1.250	0.751	0.750	0.625	5.500	0.625	0.625	1.000	1.250	0.938	0.750	0.875	7.375	8.000	8.313	8.750	8.875

\* The 5" bore BB and BE bracket is the same as the 3-1/4" BB and BE bracket. The outer square dimension E is 3.75" and use SHCS.



For inventory, lead times, and kit lookup, visit [www.pdnplu.com](http://www.pdnplu.com)

**B**  
 Tie Rod Pneumatic Cylinders  
 4MA Series  
 4MAJ Series  
 ACVB Option  
 LPSO Option  
 P1D Series  
 P1F Series  
 2MNR Series

**Head Trunnion**

\* Style D  
 (NFPA MT1)

**Note:** not available for 1-1/2" bore with 1" rod.

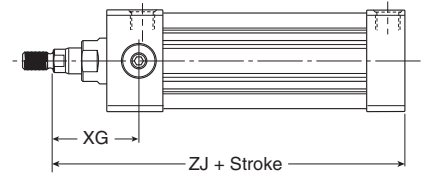
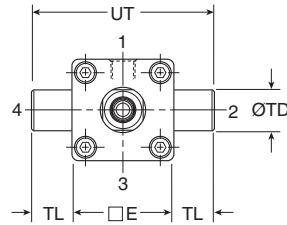
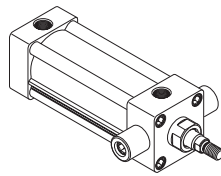

**Cap Trunnion**

Style DB  
 (NFPA MT2)

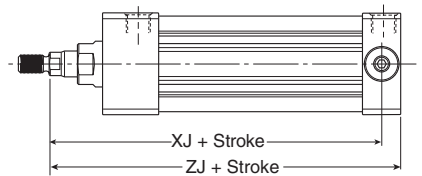
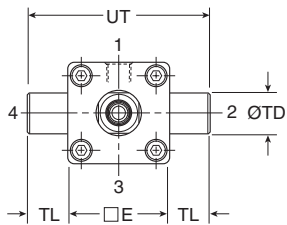
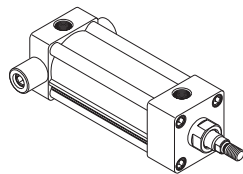

**Intermediate Trunnion**

Style DD  
 (NFPA MT4)

**Note:** Tie rod nuts for Style DD have a slot instead of internal hex.

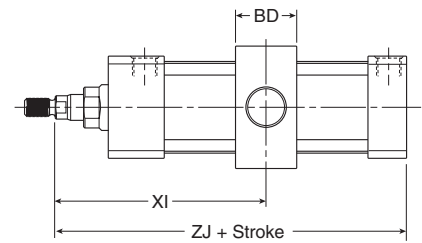
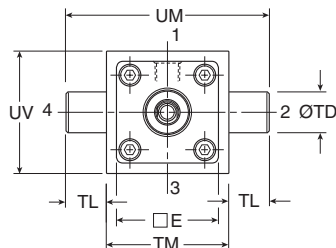
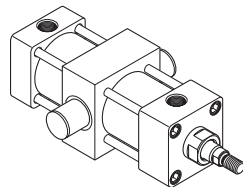

Note: Tie rod nuts for Style DD have a slot instead of internal hex.

**Styles D, DB and DD Dimensions**

Bore Size	Rod no.	Rod Dia. MM	E	BD	Rod Dia. +.000 -0.001 TD	TL	TM	UM	UT	UV	XG	Min. XI	Add Stroke	
													XJ	ZJ
1-1/2	1	5/8	2.000	1.250	1.000	1.000	2.500	4.500	4.000	2.500	1.750	3.036	4.125	4.625
	2*	1	2.000	1.250	1.000	1.000	2.500	4.500	4.000	2.500	-	3.437	4.250	5.000
2	1	5/8	2.500	1.500	1.000	1.000	3.000	5.000	4.500	3.000	1.750	3.125	4.125	4.625
	3	1	2.500	1.500	1.000	1.000	3.000	5.000	4.500	3.000	2.125	3.500	4.500	5.000
2-1/2	1	5/8	3.000	1.500	1.000	1.000	3.500	5.500	5.000	3.500	1.750	3.094	4.250	4.750
	3	1	3.000	1.500	1.000	1.000	3.500	5.500	5.000	3.500	2.125	3.469	4.625	5.125
3-1/4	1	1	3.750	2.000	1.000	1.000	4.500	6.500	5.750	4.250	2.250	3.969	5.000	5.625
	3	1-3/8	3.750	2.000	1.000	1.000	4.500	6.500	5.750	4.250	2.500	4.219	5.250	5.875
4	1	1	4.500	2.000	1.000	1.000	5.250	7.250	6.500	5.000	2.250	3.969	5.000	5.625
	3	1-3/8	4.500	2.000	1.000	1.000	5.250	7.250	6.500	5.000	2.500	4.219	5.250	5.875
5	1	1	5.500	2.000	1.000	1.000	6.250	8.250	7.500	6.000	2.250	3.969	5.250	5.875
	3	1-3/8	5.500	2.000	1.000	1.000	6.250	8.250	7.500	6.000	2.500	4.219	5.500	6.125

\* Head trunnion style D not available for 1-1/2" bore with 1" rod

**Kits & Accessories**

See page B34.



For inventory, lead times, and kit lookup, visit [www.pdnplu.com](http://www.pdnplu.com)

4MA/4ML Series – 6" and 8" Bore Size

<b>B</b>	Tie Rod Pneumatic Cylinders
	4MA Series
	4MAJ Series
	ACVB Option
	LPS0 Option
	P1D Series
	P1F Series
2MNR Series	

**PISTON SEALS (hidden)**  
Carboxylated nitrile rounded-lip piston seals combine low friction with leak-free service and long service life.

**PISTON ASSEMBLY (hidden)**  
Aluminum piston with wear band increases service life and eliminates metal-to-metal contact. Optional magnetic piston ring for use with a variety of sensors. Anaerobic adhesive is used to permanently lock and seal the piston to the rod.

**HEADS AND CAPS**  
High-strength aluminum heads and caps are anodized for corrosion resistance. We can offer customization of the endcaps for unique designs, including extra ports, duplex, tandem and many special mountings.

**PISTON ROD**  
Standard case-hardened (50-64 Rc), hard chrome plated and polished carbon steel piston rod for reliable performance, long rod seal life and low friction. Grades of stainless steel are available as options.

**ROD WIPER**  
Outboard urethane rod wiper protects the cylinder by removing external debris and adherents from the piston rod during the entire stroke.

**ROD GLAND/BEARING**  
Threaded bronze rod gland is externally removable, without cylinder disassembly, for easy maintenance. Machined flats permit the use of common tools for removal and installation. Options include HI LOAD design for side load conditions and metallic wiper design for extremely tough rod contaminant/adherent applications.

**ROD SEAL (hidden)**  
Carboxylated nitrile rounded-lip rod seal combines low friction with leak-free service and long service life.

**TIE ROD CONSTRUCTION**  
Steel tie rods and nuts for heavy-duty use. Stainless steel is available as an option.

**PORTS**  
NPTF ports are standard. Other port styles available.

**ADJUSTABLE CUSHIONS available**

**CYLINDER BODY**  
Hard anodized aluminum for corrosion resistance, maximum seal life and lower friction.

For a complete list of 4MA options, please see pages B19 and B23.



For inventory, lead times, and kit lookup, visit [www.pdnplu.com](http://www.pdnplu.com)

# Tie Rod Pneumatic Cylinders

## 4MA/4ML Series – 6" and 8" Bore Size

### Features

- Industry leading NFPA interchangeable cylinder with flexible construction
- Bore sizes – 6" and 8"
- Removable bronze alloy gland/bearing for easy maintenance
- Available in any practical stroke length
- Tube and tie rod construction for heavy duty use
- Single rod end or double rod ends
- Cushions – optional and adjustable at either end or both ends (N/A for 4ML hydraulic version)
- 20 standard mounting styles available
- RoHS compliant

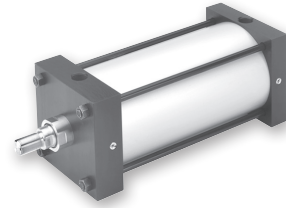

### Operating information

	4MA	4ML
Operating pressure:	250 PSIG (17 bar) maximum air service	400 PSIG (27 bar) maximum hydraulic service
Temperature range –		
Standard seals	-10°F to 165°F (-23°C to 74°C)	
Fluorocarbon seals	-10°F to 250°F (-23°C to 121°C)	
Low temperature seals	-50°F to 150°F (-46°C to 66°C)	
Filtration requirements:	40 micron, dry filtered air    Filtered hydraulic oil	

### Ordering information

<b>6.00</b>		<b>J</b>	<b>4MA</b>		<b>U</b>		<b>1</b>	<b>4</b>		<b>A</b>		<b>12.000</b>
<b>Bore Size</b>		<b>Double Rod Cylinder</b>	<b>Series</b>		<b>Ports</b>		<b>Piston Rod Number</b>			<b>Cushion Cap End</b>		<b>Stroke Length</b>
6.00 8.00		Specify "K" only if double rod cylinder is required.	4MA Air Service 4ML Hydraulic Service		U NPTF R BSPP B BSPT T SAE		Specify rod code number for required diameter. <sup>5</sup>			Blank Non-Cushioned Cap End C Cushioned Cap End (not available for 4ML)		Specify stroke length required in inches. <sup>8</sup>
		<b>Mounting Style</b>					<b>Special Modification</b>			<b>Piston Rod Thread Type</b>		
		Specify mounting style code (see table on following page).					Specify "S" only for special modification other than rod end, and then describe modification in item notes. (Includes 4MA with Linear Position Sensor Option) <sup>7</sup>			A Standard (UNF unified thread) W BSF British Fine M* Metric		
		<b>Cushion Head End</b>								* Please reference page B78.		
		Blank Non-Cushioned Head End C Cushioned Head End (not available for 4ML)										
		<b>Piston Type</b>			<b>Seals</b>					<b>Rod Material and Gland Code</b>		
		Blank Standard (lipseals and no magnetic ring) 3 Lipseals and Magnetic Ring			Blank Standard (nitrile seals) V Fluorocarbon Seals <sup>1</sup> E Fluorocarbon Rod Wiper and Rod Seal Only <sup>2</sup> 4 Low Temperature Seals <sup>1</sup> M Metallic Rod Wiper, Nitrile Seals <sup>3</sup>					Blank Standard Rod and Gland H Standard Rod and HI LOAD Gland <sup>9</sup> Y 17-4 PH Stainless Steel Rod and Standard Gland Z 17-4 PH Stainless Steel Rod and HI LOAD Gland <sup>9</sup> J 303 Stainless Steel Rod and Standard Gland <sup>7</sup> K 303 Stainless Steel Rod and HI LOAD Gland <sup>7,9</sup> S 316 Stainless Steel Rod and Standard Gland <sup>7</sup> T 316 Stainless Steel Rod and HI LOAD Gland <sup>7,9</sup>		
							<b>Piston Rod Thread Style</b>					
							4 Small Male 8 Intermediate Male 9 Short Female 55 For Use with Split Coupler <sup>6</sup> 3 Special (and specify all dimensions required) 6 Full Male					

**Sensors**  
See section L for sensors.

<sup>1</sup> Reed and solid-state sensors only available with standard seals or options E and M.  
<sup>2</sup> Used for external chemical compatibility applications, not high temperature.  
<sup>3</sup> If fluorocarbon seals are required with this option, please place an "S" for special in the Special Modification field and specify the "fluorocarbon seals and metallic rod wiper" in the item notes.  
<sup>4</sup> For Linear Position Sensor Option (LPSO), please include the following information for the Special Modification item notes:  
 a. Sensor part number (please reference pages B72-B76)  
 b. Sensor position  
 c. Port position (if other than position 1)  
 d. Length of stop tubing, gross stroke and net stroke (if required)  
 Also, Piston Type 3 is required.  
<sup>5</sup> Review Piston Rod Selection Chart, please reference page A14 to determine proper piston rod diameter.  
<sup>6</sup> For additional information regarding this style, please reference page B77. If non-standard Rod Material and Gland Code is required with this option, please place an "S" for special in Special Modification field and specify Rod Material and Gland Code in the item notes.  
<sup>7</sup> Not available for 4ML.  
<sup>8</sup> If a stop tube is required, specify gross stroke (net stroke + stop tube) in the model number, then place an "S" for special in the Special Modification field and specify the stop tube length in the item notes.  
<sup>9</sup> Not available with Metallic rod wiper.

For ordering purposes, when special options or common modifications are requested, the factory will assign a sequential part number in place of the model number.



For inventory, lead times, and kit lookup, visit [www.pdnplu.com](http://www.pdnplu.com)

**4MA/4ML Mounting Styles for 6" & 8" Bore**

Mounting Style	NFPA Mounting	Description	Bore Size
T	MX0	No Mount	6 - 8
J	MF1	Head Rectangular Flange	6
H	MF2	Cap Rectangular Flange	6
TB	MX3	Tie Rods Extended Head End	6 - 8
TC	MX2	Tie Rods Extended Cap End	6 - 8
TD	MX1	Tie Rods Extended Both Ends	6 - 8
TE	MX5	Sleeve Nut	6 - 8
TEF	MX5/MS4	Sleeve Nut with Side Tap	6 - 8
C	MS2	Side Lug	6 - 8
F	MS4	Side Tap	6 - 8

Mounting Style	NFPA Mounting	Description	Bore Size
CB	MS1	Side End Angle	6 - 8
BB	MP1	Cap Fixed Clevis	6 - 8
BC	MP2	Cap Detachable Clevis	6 - 8
BE	MP4	Cap Detachable Eye	6
D	MT1	Head Trunnion	6 - 8
DB	MT2	Cap Trunnion	6 - 8
DD	MT4	Intermediate Trunnion	6 - 8
JB	ME3	Head Square	8
HB	ME4	Cap Square	8
KT †	MDX0	Double Rod End, No Mount	6 - 8

† Double rod end cylinders can be ordered with head mountings, i.e. KJ.

**B**  
 Tie Rod Pneumatic Cylinders  
 4MA Series  
 4MAJ Series  
 ACVB Option  
 LP50 Option  
 P1D Series  
 P1F Series  
 2MNR Series



For inventory, lead times, and kit lookup, visit [www.pdnplu.com](http://www.pdnplu.com)

**General Specifications**

- NFPA interchangeable
  - Bore sizes – 6" and 8"
  - Strokes – available in any practical stroke length
  - Rod diameters – 1-3/8" and 1-3/4"
  - Rod end styles – 4 standard, specials available
  - Single rod end or double rod ends
  - Cushions – optional and adjustable at either end or both ends (N/A for 4ML Hydraulic Version)
  - Operating pressure –  
 4MA = 250 PSIG (17 Bar) maximum air service  
 4ML = 400 PSIG (27 Bar) maximum hydraulic service
  - Media – 4MA = dry, filtered air  
 4ML = filtered hydraulic oil
  - Temperature range –  
 -10°F to 165°F (-23°C to 74°C) standard seals  
 -10°F to 250°F (-23°C to 121°C) fluorocarbon seals option  
 -50°F to 150°F (-46°C to 66°C) low temperature seals option
  - Mounting styles – 20 standard styles
  - RoHS compliant
- For material options, including seals, piston rods and glands, please see Material Specifications on next page.

**Cylinder Weights**

Bore (inch)	Rod (inch)	No Mount Single Rod 4MA/4ML		No Mount Double Rod	
		Base Wt. (lbs.)	Per Inch (lbs.)	Base Wt. (lbs.)	Per Inch (lbs.)
6	1.375	20.50	0.87	25.65	1.30
	1.75	22.61	1.13	30.41	1.82
8	1.375	35.50	1.25	41.15	1.68
	1.75	37.63	1.51	45.90	2.20

**Mounting Weight Adders**

Bore (inch)	Mounting Style, Weight (lbs)							
	J, H	D, DB	BB	CB	DD	BE	C	BC
6	10.74	1.22	2.91	5.88	15.52	2.91	0.69	11.38
8	N/A	1.22	2.91	7.84	25.01	N/A	0.67	17.31

**Standard Cushion Position**

Mounting Code	Position
All except D, DB, DD	2
D, DB, DD	3

**Standard Port Sizes**

Bore	NPTF	BSPT	BSPP	SAE
6	3/4	Rc3/4	G3/4	12
8	3/4	Rc3/4	G3/4	12

**B**

Tie Rod Pneumatic Cylinders

4MA Series

4MAJ Series

ACVB Option

LPSO Option

P1D Series

P1F Series

2MNR Series



For inventory, lead times, and kit lookup, visit [www.pdnplu.com](http://www.pdnplu.com)

## Material Specifications

### Standard Temperatures and Applications

Head and cap	Black anodized aluminum alloy
Cylinder body	Clear hard-coat anodized aluminum alloy
Piston rod	Case-hardened, chrome plated carbon steel
Rod seal	Carboxylated nitrile (Nitroxile)
Rod wiper	Molythane
Rod bearing (gland)	Bronze alloy
Piston	Aluminum alloy
Piston seals	Carboxylated nitrile (Nitroxile)
Piston bearing	MolyGard™
Magnetic ring	Plastic-bound magnetic material
Piston fastener	Piston rod for aluminum piston
O-rings	Nitrile
End seals	Nitrile
Cushion seals	Urethane
Cushion needle valves	Brass cushion needle valves
Tie-rod	Blackened carbon steel
Tie-rod nuts	Steel alloy, SAE J995 Grade 8

## Tie Rod Pneumatic Cylinders 4MA/4ML Series – 6" and 8" Bore Size

### Material and Part Changes

#### 4MA Options

High temperatures (-10°F to 250°F)	All seals and wiper are fluorocarbon Aluminum piston without magnetic ring
Low temperatures (-50°F to 150°F)	Rod seal, piston seals, o-rings and end seals are low temperature-rated nitrile

#### 4ML Hydraulic Version

Hydraulic service (general)	Cushions not available
Hydraulic service (std temp)	Polyurethane TS-2000 rod seal and nitrile piston seals (for hydraulic use)
Hydraulic service (high temp)	Fluorocarbon TS-2000 rod seal; wiper and all seals are fluorocarbon (for hydraulic use)

#### Other Standard Options

Cylinder seal options	Fluorocarbon for high temperatures or chemical compatibility Other seal options available, please consult factory
Piston rod material options	Case-hardened, chrome plated carbon steel (standard) 17-4 PH stainless steel, chrome plated 303 stainless steel, chrome plated (N/A for 4ML) 316 stainless steel, chrome plated (N/A for 4ML) For stainless steel without chrome plating, please consult factory
HI LOAD gland option	Composite bearing pressed into bronze alloy gland
Metallic rod scraper option	Dual high strength bronze wipers with fluorocarbon energizer

**B**  
 Tie Rod Pneumatic Cylinders  
 4MA Series  
 4MAJ Series  
 ACVB Option  
 LP50 Option  
 P1D Series  
 P1F Series  
 2MNR Series



For inventory, lead times, and kit lookup, visit [www.pdnplu.com](http://www.pdnplu.com)



**How to Select a 6" - 8" Bore 4MA Cylinder**

Parker cylinders are available based on air or hydraulic operating pressure. The many styles, sizes and optional features available assure that your application requirements are precisely met. To select a cylinder, follow these simple steps:

- Step 1 - **Determine the correct cylinder bore size** necessary to achieve required force using the available operating pressure.
- Step 2 - **Determine the series cylinder to use**, based on operating pressure.
- Step 3 - **Turn to the appropriate cylinder selection section.** Select the mounting style that fits your installation needs. Determine the bore and rod sizes available for the model you select. Then complete model selection.
  - Choose a rod end style and the desired rod end accessories.
  - Size the cylinder to meet your application requirements.
- Step 4 - **Consider the following conditions** which may require further modifications to the cylinder you have selected.

Application Condition	Check the Following
Quick Starts or Stops	Confirm that determined thrust is sufficient to accelerate or decelerate cylinder and load within prescribed distance. Optional cushions should be used to reduce shock during deceleration, check that peak pressures will be within tolerable limits.
Long Push Stroke	Check whether stop tube is required to prevent excessive bearing loads and wear.
High-column Loading Long Push Stroke	Determine if standard size piston rod is strong enough to accommodate intended load. See Application Engineering section for recommendations.
Long Horizontal Stroke	Determine if standard size piston rod is strong enough to accommodate intended load.
High Operating Temperatures	For temperatures between 165°F and 250°F use 4MA cylinder with high temperature seals.

**General Options and Modifications:**

- Adjustable Cushions
- Magnetic Piston
- Port and Adjustable Cushion Relocation
- Port Thread Styles
- Multiple Ports
- Special Heads, Caps, Pistons and Mounts
- Double Rod End
- Oversize Rod Diameters
- Rod End Modifications
- Rod Materials (grades of stainless steel)
- Stainless Steel Tie Rods and Nuts
- Fluorocarbon Rod Wiper and Rod Seal only
- Fluorocarbon Seals (all cylinder seals)
- Metallic Rod Wiper
- HI LOAD Gland Assembly
- Stop Tube
- Mixed Mountings
- Shock Absorber on Cap End
- Air Cylinder/Valve Combination (ACVB)
- Adjustable Point Sensors (order separately)
- Continuous Linear Position Sensing (LPSO)
- High Temperature Service (to 250°F)
- Low Temperature Service (to -50°F)
- Hydraulic Service (4ML) (400 PSIG)
- Rod lock version (see 4MAJ)

**B**

Tie Rod Pneumatic Cylinders

4MA Series

4MAJ Series

ACVB Option

LPSO Option

P1D Series

P1F Series

2MNR Series



For inventory, lead times, and kit lookup, visit [www.pdnplu.com](http://www.pdnplu.com)

**Style T**

**Tie Rod Pneumatic Cylinders  
4MA/4ML Series – 6" and 8" Bore Size**

**Single Rod  
(Style T)**

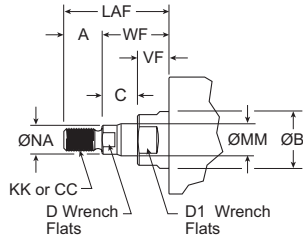
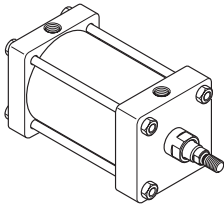

For dimensions of all standard rod end styles, please see next page.

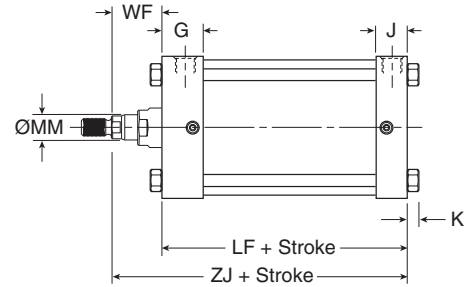
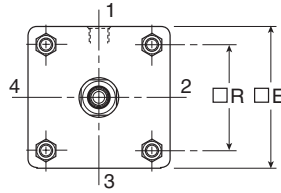
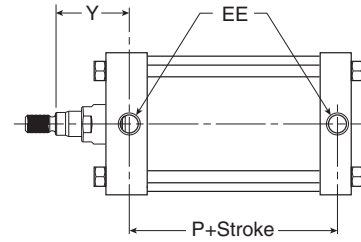

**Style T Dimensions**

Bore Size	Rod No.	Rod Dia. MM	Thread		Style 6	A	AA	B	C	D	D1	E	EE (NPTF)	G
			Style 8 CC	Style 4 & 9 KK										
6	1	1-3/8	1-1/4 - 12	1-14	1-3/8 - 14	1.625	6.900	1.999	0.635	1-1/8	1-7/8	6.500	3/4	1.910
	3	1-3/4	1-1/2 - 12	1-1/4 - 12	1-3/4 - 12	2.000	6.900	2.374	0.760	1-1/2	2-3/16	6.500	3/4	1.910
8	1	1-3/8	1-1/4 - 12	1-14	1-3/8 - 14	1.625	9.100	1.999	0.635	1-1/8	1-7/8	8.500	3/4	1.810
	3	1-3/4	1-1/2 - 12	1-1/4 - 12	1-3/4 - 12	2.000	9.100	2.374	0.760	1-1/2	2-3/16	8.500	3/4	1.810

Bore Size	Rod No.	Rod Dia. MM	Add Stroke										
			J	K	LAF	NA	R	VF	WF	Y	LF	P	ZJ
6	1	1-3/8	1.410	0.438	3.250	1.313	4.880	0.990	1.625	2.813	5.000	3.125	6.625
	3	1-3/4	1.410	0.438	3.875	1.688	4.880	1.115	1.875	3.063	5.000	3.125	6.875
8	1	1-3/8	1.440	0.563	3.250	1.313	6.440	0.990	1.625	2.750	5.125	3.250	6.750
	3	1-3/4	1.440	0.563	3.875	1.688	6.440	1.115	1.875	3.000	5.125	3.250	7.000

**B**  
Tie Rod Pneumatic Cylinders

4MA Series

4MAJ Series

ACVB Option

LPS0 Option

P1D Series

P1F Series

2MNR Series



For inventory, lead times, and kit lookup, visit [www.pdnplu.com](http://www.pdnplu.com)

# Rod End Thread Styles

# Tie Rod Pneumatic Cylinders 4MA/4ML Series – 6" and 8" Bore Size

## Rod End

### Thread Style 4

(NFPA Style SM)  
Small Male

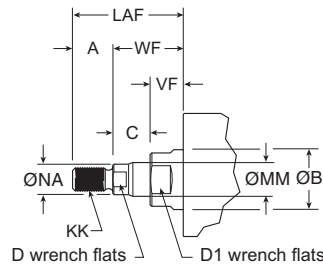

### Thread Style 8

(NFPA Style IM)  
Intermediate Male

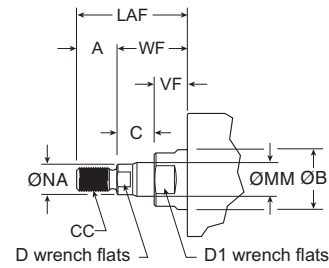

### Thread Style 9

(NFPA Style SF)  
Short Female

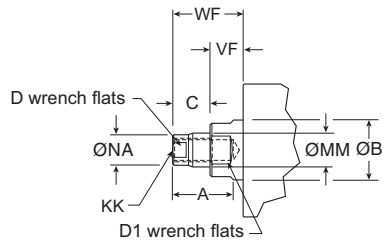

### Thread Style 55

For use with Split Coupler  
(please reference page B77 for more information)

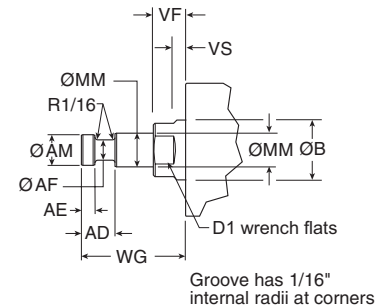

### Thread Style 3 - "Special Thread"

Special threads, rod extensions, rod eyes, blanks, etc. are also available.  
To order, specify "Style 3" and give desired dimensions for KK or CC, A and W or WF.  
If otherwise special, please supply dimensioned sketch.

## Rod End Dimensions

Bore Size	Rod No.	Rod Dia. MM	Thread		Style 6	A	AD	AE	AF	AM	B	C	D	D1	LAF	NA	VF	WF	WG
			Style 8 CC	Style 4 & 9 KK															
6	1	1-3/8	1-1/4 - 12	1 - 14	1-3/8 - 14	1.625	1.063	0.375	0.875	1.320	1.999	0.635	1-1/8	1-7/8	3.250	1.313	0.990	1.625	2.750
	3	1-3/4	1-1/2 - 12	1-1/4 - 12	1-3/4 - 12	2.000	1.313	0.500	1.125	1.700	2.374	0.760	1-1/2	2-3/16	3.875	1.688	1.115	1.875	3.125
8	1	1-3/8	1-1/4 - 12	1 - 14	1-3/8 - 14	1.625	1.063	0.375	0.875	1.320	1.999	0.635	1-1/8	1-7/8	3.250	1.313	0.990	1.625	2.750
	3	1-3/4	1-1/2 - 12	1-1/4 - 12	1-3/4 - 12	2.000	1.313	0.500	1.125	1.700	2.374	0.760	1-1/2	2-3/16	3.875	1.688	1.115	1.875	3.125

**B**

Tie Rod Pneumatic Cylinders

4MA Series

4MAJ Series

ACVB Option

LPSO Option

P1D Series

P1F Series

2MNR Series



For inventory, lead times, and kit lookup, visit [www.pdnplu.com](http://www.pdnplu.com)

# K-type Cylinder

To determine dimensions for a double rod end cylinder, first refer to the desired single rod end mounting style cylinder shown in this catalog section. After selecting the necessary dimensions from that drawing, return to this page and supplement the single rod end dimensions with those shown in the drawings and dimension table below. Note that double rod end cylinders have a head dimension G at both ends, and

# Tie Rod Pneumatic Cylinders 4MA/4ML Series – 6" and 8" Bore Size

that LG replaces LF, PK replaces P, etc. The double rod end dimensions differ from, or are in addition to, those for single rod cylinders.

When a double rod end cylinder has two different rod ends, please clearly state which rod end is to be available at which head end.

## K-type for 6" & 8" bore

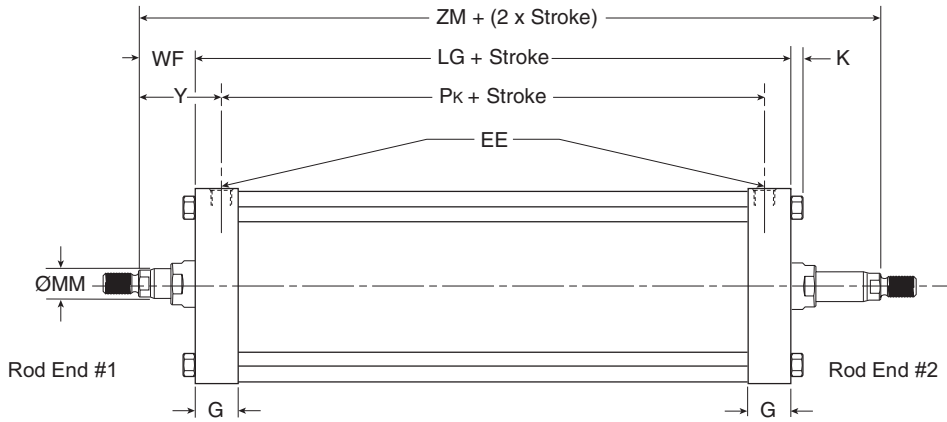

Mounting Styles For Single Rod Models	Corresponding Mounting Styles For Double Rod Models
C	KC
CB	KCB
D	KD
DD	KDD
F	KF
J	KJ
T	KT
TB	KTB
TD	KTD
TE	KTE
TEF	KTEF

## Style KT Dimensions

Bore Size	Rod No.	Rod Dia. MM	EE (NPTF)	G	K	WF	Y	Add Stroke					Add 2X Stroke ZM		
								LG	Pk	SAk	XAk	SSk		SNk	
6	1	1-3/8	3/4	1.910	0.438	1.625	2.813	5.500	3.125	8.250	8.500	4.125	3.125	8.750	
	3	1-3/4	3/4	1.910	0.438	1.875	3.063	5.500	3.125	8.250	8.750	4.125	3.125	9.250	
8	1	1-3/8	3/4	1.810	0.563	1.625	2.750	5.500	3.250	9.125	8.938	4.125	3.125	8.750	
	3	1-3/4	3/4	1.810	0.563	1.875	3.000	5.500	3.250	9.125	9.188	4.125	3.125	9.250	
								Replaces Dimension	LF	P	SA	XA	SS	SN	-
								On Single Rod Mounting Styles	All Styles	All Styles	CB	CB	C	F, TEF	All

**B**  
 Tie Rod Pneumatic Cylinders  
 4MA Series  
 4MAJ Series  
 ACVB Option  
 LP50 Option  
 P1D Series  
 P1F Series  
 2MNR Series



For inventory, lead times, and kit lookup, visit [www.pdnplu.com](http://www.pdnplu.com)

# Style J, H

# Tie Rod Pneumatic Cylinders 4MA/4ML Series – 6" and 8" Bore Size

## Head Rectangular Flange

Style J  
(NFFA MF1)  
(only 6" Bore)

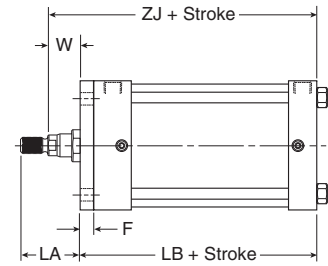
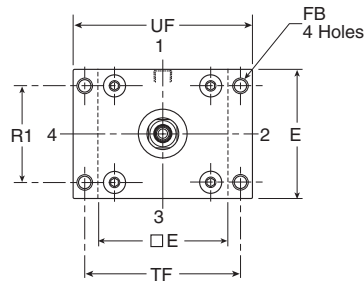
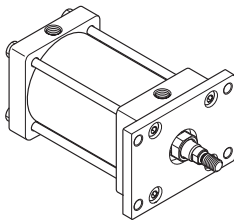

**Note:** Style J has a W dimension instead of WF and a LA dimension instead of LAF because of the flange installation. Please use dimensions W and LA regarding rod ends only for Style J. For reference,  $WF = W + F$  and  $LA = W + A$ .

## Cap Rectangular Flange

Style H  
(NFFA MF2)  
(only 6" Bore)

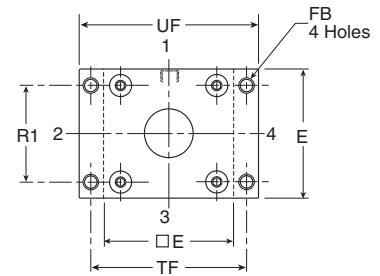
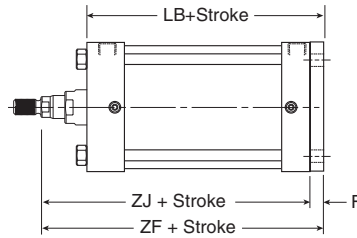
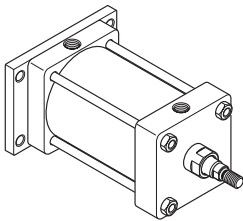

## Styles J and H Dimensions

Bore Size	Rod No.	Rod Dia. MM	A	E	F	FB	LA	R1	TF	UF	W	Add Stroke		
												LB	ZF	ZJ
6	1	1-3/8	1.625	6.500	0.750	0.563	2.500	4.880	7.625	8.625	0.875	5.750	7.375	6.625
	3	1-3/4	2.000	6.500	0.750	0.563	3.125	4.880	7.625	8.625	1.125	5.750	7.625	6.875

**B**

Tie Rod Pneumatic Cylinders

4MA Series

4MAJ Series

ACVB Option

LPSO Option

P1D Series

P1F Series

2MNR Series



For inventory, lead times, and kit lookup, visit [www.pdnplu.com](http://www.pdnplu.com)

**Tie Rods Ext. Head End**

Style TB  
 (NFPA MX3)

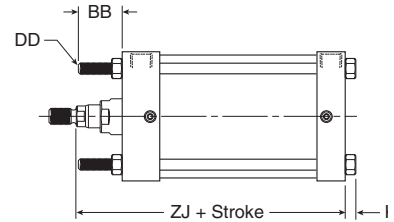
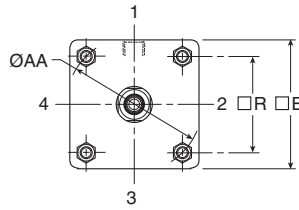
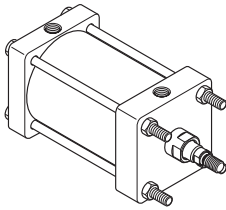

**Tie Rods Ext. Cap End**

Style TC  
 (NFPA MX2)

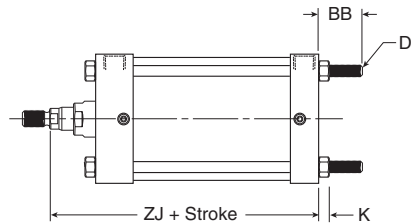
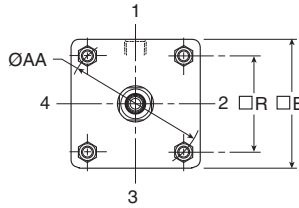
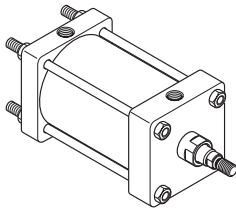

**Tie Rods Ext. Both Ends**

Style TD  
 (NFPA MX1)

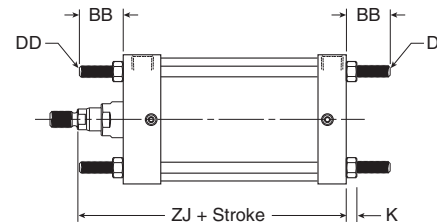
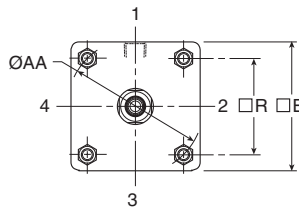
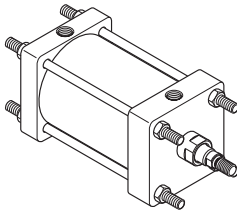

**Styles TB, TC and TD Dimensions**

Bore Size	Rod No.	Rod Dia. MM	AA	BB	DD	E	K	R	Add Stroke	
									ZJ	
6	1	1-3/8	6.900	1.813	1/2-20	6.500	0.438	4.880	6.625	
	3	1-3/4	6.900	1.813	1/2-20	6.500	0.438	4.880	6.875	
8	1	1-3/8	9.100	2.313	5/8-18	8.500	0.563	6.440	6.750	
	3	1-3/4	9.100	2.313	5/8-18	8.500	0.563	6.440	7.000	

**B**  
 Tie Rod Pneumatic Cylinders  
 4MA Series  
 4MAJ Series  
 ACVB Option  
 LP50 Option  
 P1D Series  
 P1F Series  
 2MNR Series



For inventory, lead times, and kit lookup, visit [www.pdnplu.com](http://www.pdnplu.com)

**Sleeve Nut**

Style TE  
 (NFPA MX5)

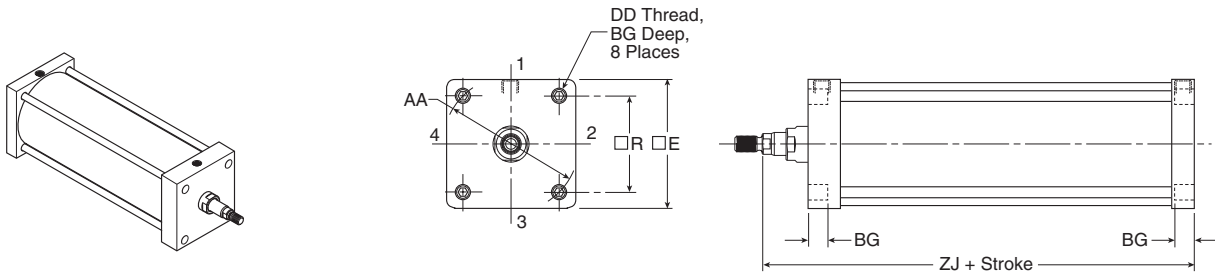

**Style TE Dimensions**

Bore Size	Rod No.	Rod Dia. MM	AA	BG	DD	E	R	Add Stroke
								ZJ
6	1	1-3/8	6.900	0.500	1/2-20	6.500	4.880	6.625
	3	1-3/4	6.900	0.500	1/2-20	6.500	4.880	6.875
8	1	1-3/8	9.100	0.620	5/8-18	8.500	6.440	6.750
	3	1-3/4	9.100	0.620	5/8-18	8.500	6.440	7.000

**Side End Angle**

\* Style CB  
 (NFPA MS1)

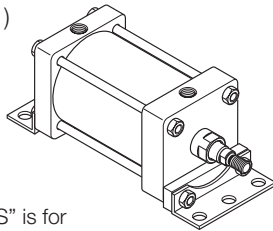

**Note:**  
 Dimension "S" is for the holes in the mount (not the screw to screw dimension)

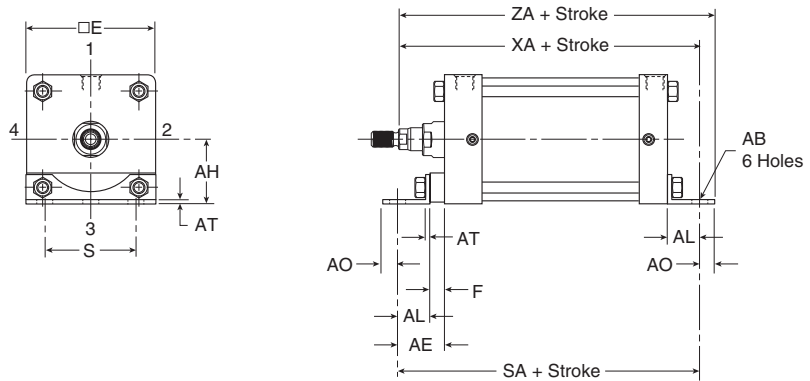

\*Maximum recommended pressure for this mount is 150 PSIG

**Style CB Dimensions**

Bore Size	Rod No.	Rod Dia. MM	AB	AE	AH	AL	AO	AT	E	F	S	Add Stroke		
												SA	XA	ZA
6	1	1-3/8	0.813	2.125	3.250	1.375	0.625	0.188	6.500	0.750	5.250	8.500	8.000	8.625
	3	1-3/4	0.813	2.125	3.250	1.375	0.625	0.188	6.500	0.750	5.250	8.500	8.250	8.875
8	1	1-3/8	0.813	1.813	4.250	1.813	0.688	0.250	8.500	-	7.125	8.750	8.563	9.250
	3	1-3/4	0.813	1.813	4.250	1.813	0.688	0.250	8.500	-	7.125	8.750	8.813	9.500

<b>B</b>	Tie Rod Pneumatic Cylinders
4MA Series	
4MAJ Series	
ACVB Option	
LPSO Option	
P1D Series	
P1F Series	
2MNR Series	



For inventory, lead times, and kit lookup, visit [www.pdnplu.com](http://www.pdnplu.com)



**Style C, F**

**Tie Rod Pneumatic Cylinders  
4MA/4ML Series – 6" and 8" Bore Size**

**Side Lug**

Style C  
(NFPA MS2)

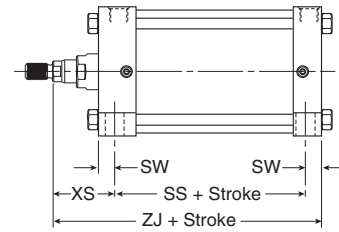
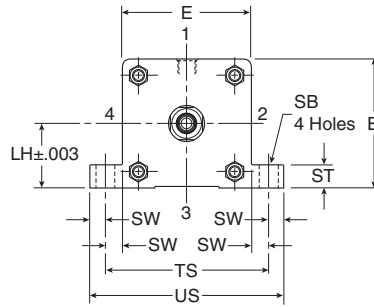
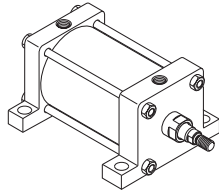

**Style C Dimensions**

Bore Size	Rod No.	Rod Dia. MM	E	+/- .003 LH	SB	ST	SW	TS	US	XS	Add Stroke	
											SS	ZJ
6	1	1-3/8	6.500	3.243	0.813	1.000	0.688	7.875	9.250	2.313	3.625	6.625
	3	1-3/4	6.500	3.243	0.813	1.000	0.688	7.875	9.250	2.563	3.625	6.875
8	1	1-3/8	8.500	4.243	0.813	1.000	0.688	9.875	11.250	2.313	3.750	6.750
	3	1-3/4	8.500	4.243	0.813	1.000	0.688	9.875	11.250	2.563	3.750	7.000

**Side Tap**

Style F  
(NFPA MS4)

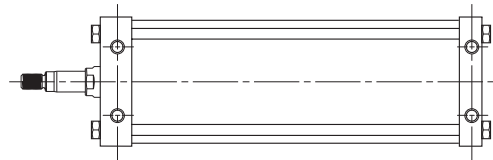
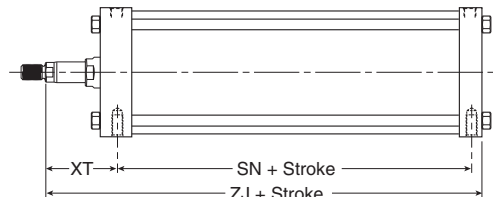
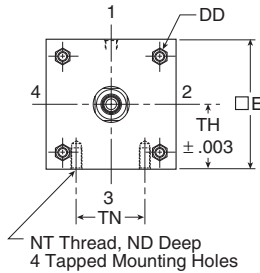
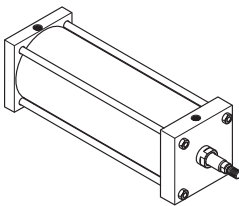

**Style F Dimensions**

Bore Size	Rod No.	Rod Dia. MM	E	ND	NT	+/- .003 TH	TN	XT	Add Stroke	
									SN	ZJ
6	1	1-3/8	6.500	1.125	3/4-10	3.243	3.250	2.813	3.125	6.625
	3	1-3/4	6.500	1.125	3/4-10	3.243	3.250	3.063	3.125	6.875
8	1	1-3/8	8.500	1.125	3/4-10	4.243	4.500	2.813	3.250	6.750
	3	1-3/4	8.500	1.125	3/4-10	4.243	4.500	3.063	3.250	7.000

**B**  
 Tie Rod Pneumatic Cylinders  
 4MA Series  
 4MAJ Series  
 ACVB Option  
 LPSO Option  
 P1D Series  
 P1F Series  
 2MNR Series



For inventory, lead times, and kit lookup, visit [www.pdnplu.com](http://www.pdnplu.com)

B30

**Parker Hannifin Corporation**  
 Pneumatic Division  
 Wadsworth, Ohio  
[www.parker.com/pneumatics](http://www.parker.com/pneumatics)

**Cap Fixed Clevis**

Style BB  
 (NFPA MP1)

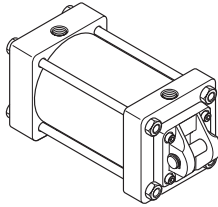

**Note:** For maximum swivel angle of BB mount with rear mounting plate, please reference cylinder accessories on page B80.

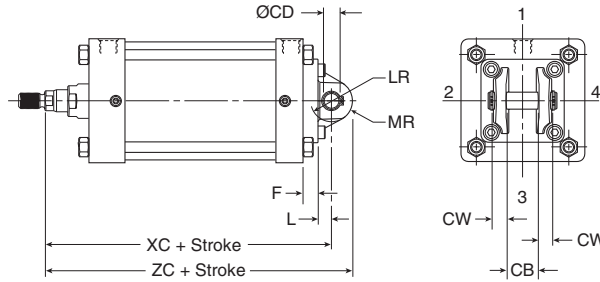

**Cap Detachable Clevis**

Style BC  
 (NFPA MP2)

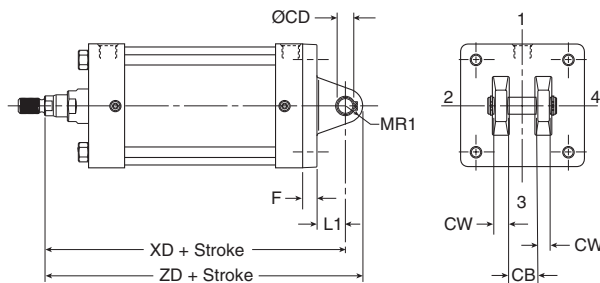
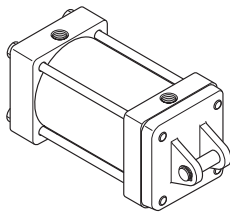

**Styles BB and BC Dimensions**

Bore Size	Rod No.	Rod Dia. MM	CB	Rod Dia. +.000 -0.002 CD	CW	E	F	L	LR	L1	MR	MR1	Add Stroke			
													XC	XD	ZC	ZD
6	1	1-3/8	1.500	1.001	0.750	6.500	0.750	0.750	1.250	1.500	1.125	1.000	8.125	8.875	9.250	9.875
	3	1-3/4	1.500	1.001	0.750	6.500	0.750	0.750	1.250	1.500	1.125	1.000	8.375	9.125	9.500	10.125
8	1	1-3/8	1.500	1.001	0.750	8.500	0.750	0.750	1.250	1.500	1.125	1.000	8.250	9.000	9.375	10.000
	3	1-3/4	1.500	1.001	0.750	8.500	0.750	0.750	1.250	1.500	1.125	1.000	8.500	9.250	9.625	10.250

**Cap Detachable Eye**

Style BE  
 (NFPA MP4)  
 (only 6" Bore)

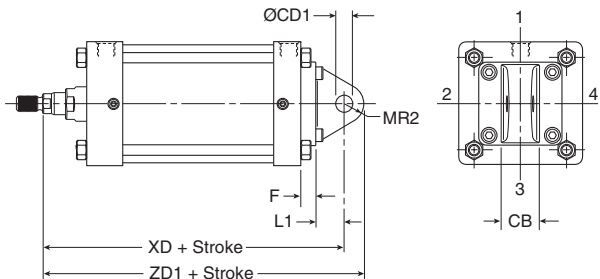
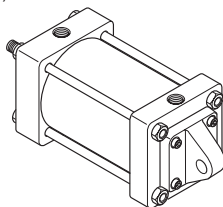

**Style BE Dimensions**

Bore Size	Rod No.	Rod Dia. MM	CB	Rod Dia. +.002 +.004 CD1	E	F	L1	MR2	Add Stroke	
									XD	ZD1
6	1	1-3/8	1.500	1.000	6.500	0.750	1.500	1.125	8.875	10.000
	3	1-3/4	1.500	1.000	6.500	0.750	1.500	1.125	9.125	10.250

<b>B</b>	Tie Rod Pneumatic Cylinders
	4MA Series
4MAJ Series	
ACVB Option	
LPSO Option	
P1D Series	
P1F Series	
2MNR Series	



For inventory, lead times, and kit lookup, visit [www.pdnplu.com](http://www.pdnplu.com)

**Head Trunnion**

Style D  
 (NFPA MT1)

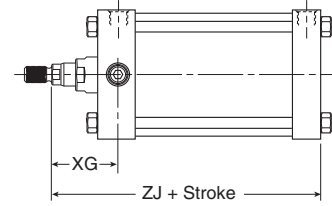
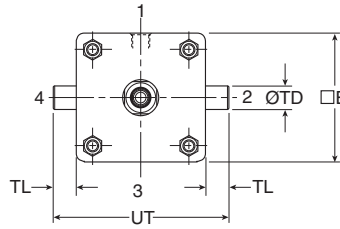
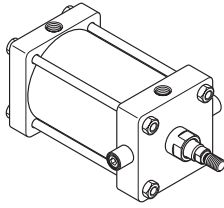

**Cap Trunnion**

Style DB  
 (NFPA MT2)

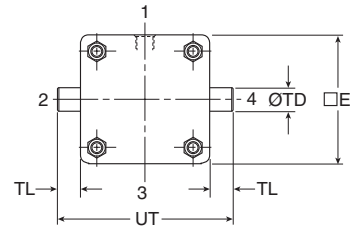
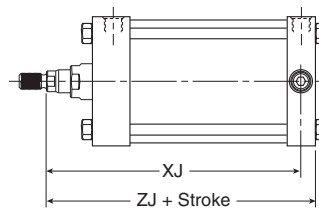
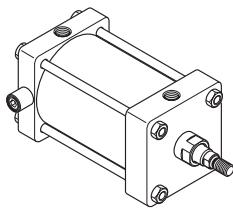

**Intermediate Trunnion**

Style DD  
 (NFPA MT4)

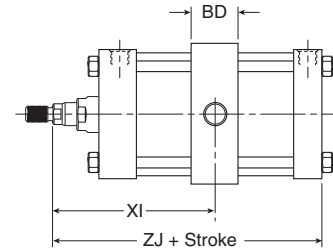
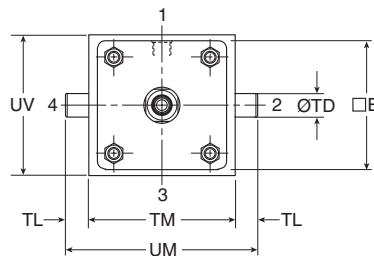
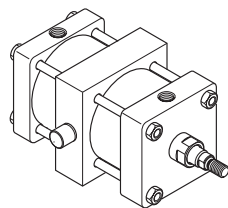

**Styles D, DB and DD Dimensions**

Bore Size	Rod No.	Rod Dia. MM	E	BD	Rod Dia. +.000 / -.001 TD	TL	TM	UM	UT	UV	XG	Min. XI	Add Stroke	
													XJ	ZJ
6	1	1-3/8	6.500	2.500	1.375	1.375	7.625	10.375	9.250	7.000	2.625	4.813	5.875	6.625
	3	1-3/4	6.500	2.500	1.375	1.375	7.625	10.375	9.250	7.000	2.875	5.063	6.125	6.875
8	1	1-3/8	8.500	2.500	1.375	1.375	9.750	12.500	11.250	9.500	2.625	4.750	6.000	6.750
	3	1-3/4	8.500	2.500	1.375	1.375	9.750	12.500	11.250	9.500	2.875	5.000	6.250	7.000

**B**  
 Tie Rod Pneumatic Cylinders  
 4MA Series  
 4MAJ Series  
 ACVB Option  
 LPSO Option  
 P1D Series  
 P1F Series  
 2MNR Series



For inventory, lead times, and kit lookup, visit [www.pdnplu.com](http://www.pdnplu.com)

**Head Square**

Style JB  
 (NFPA ME3)

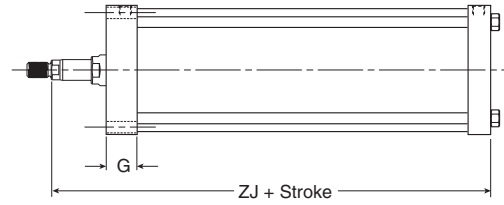
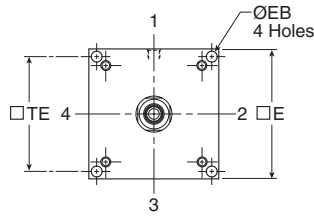
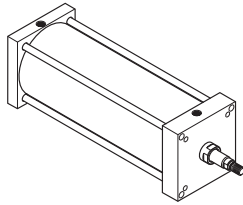

**Cap Square**

Style HB  
 (NFPA ME4)

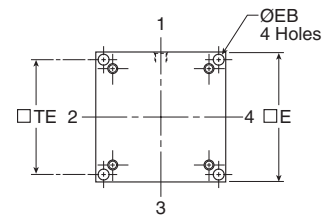
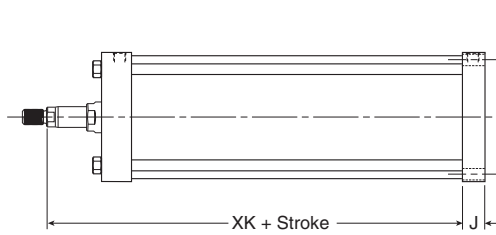
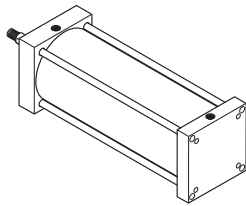

**Styles JB and HB Dimensions**

Bore Size	Rod No.	Rod Dia. MM	E	EB	G	J	TE	Add Stroke	
								XK	ZJ
8	1	1-3/8	8.500	0.688	1.810	1.440	7.570	5.313	6.750
	3	1-3/4	8.500	0.688	1.810	1.440	7.570	5.563	7.000

<b>B</b>	Tie Rod Pneumatic Cylinders
	4MA Series
4MAJ Series	ACVB Option
LPSO Option	P1D Series
P1F Series	2MNR Series



Mounting Kits and Accessories

Bore Size	J (MF1)	H (MF2)	BB (MP1)	BC (MP2)	BE (MP4)	CB (MS1)	G (MS7)	Kit Fastener Torque Units	
	Head Rectangular Flange	Cap Rectangular Flange	Cap Fixed Clevis	Cap Detachable Clevis	Cap Detachable Eye	Side End Angles	Side End Lug	inch-lbs	N-m
	Kit Number	Kit Number	Kit Number	Kit Number	Kit Number	Kit Number	Kit Number		
1-1/2	L079700150	L079700150	L079710150	L079730150	L079720150	L079740150	L079750150	32-36	3.6-4.1
2	L079700200	L079700200	L079710200	L079730200	L079720200	L079740200	L079750200	72-82	8-9
2-1/2	L079700250	L079700250	L079710250	L079730250	L079720250	L079740250	L079750250	72-82	8-9
3-1/4	L079700325	L079700325	L079710325	L079730325	L079720325	L079740325	L079750325	216-228	24-25.3
4	L079700400	L079700400	L079710400	L079730400	L079720400	L079740400	L079750400	216-228	24-25.3
5	L079700500	L079700500	L079710500	L079730500	N/A	L079740500	N/A	360-372	41-42

\*\* Spacer plate not used for 4" bore or double rod cylinders

Female Rod Clevis

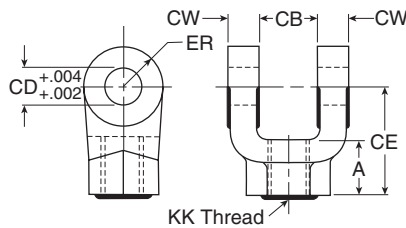

Symbol	1458030044	1458030050	1458030075	1458030088	1458030100	1458030125	1458030150
A	3/4	3/4	1-1/8	1-5/8	1-5/8	2	2-1/4
CB	3/4	3/4	1-1/4	1-1/2	1-1/2	2	2-1/2
CD	1/2	1/2	3/4	1	1	1-3/8	1-3/4
C E	1-1/2	1-1/2	2-1/8	2-15/16	2-15/16	3-3/4	4-1/2
CW	1/2	1/2	5/8	3/4	3/4	1	1-1/4
ER	1/2	1/2	3/4	1	1	1-3/8	1-3/4
KK	7/16-20	1/2-20	3/4-16	7/8-14	1-14	1-1/4-12	1-1/2-12
Load Capacity (lbs)	4250	4900	11200	18800	19500	33500	45600

Rod Eye Knuckle

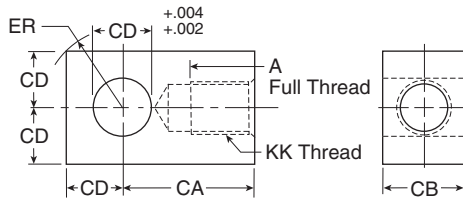

Symbol	1458040044	1458040050	1458040075	1458040088	1458040100	1458040125	1458040150
A	3/4	3/4	1-1/8	1-1/8	1-5/8	2	2-1/4
CA	1-1/2	1-1/2	2-1/16	2-3/8	2-13/16	3-7/16	4
CB	3/4	3/4	1-1/4	1-1/2	1-1/2	2	2-1/2
CD	1/2	1/2	3/4	1	1	1-3/8	1-3/4
ER	23/32	23/32	1-1/16	1-7/16	1-7/16	1-31/32	2-1/2
KK	7/16-20	1/2-20	3/4-16	7/8-14	1-14	1-1/4-12	1-1/2-12
Load Capacity (lbs)	5000	5700	12100	13000	21700	33500	45000

Clevis Bracket

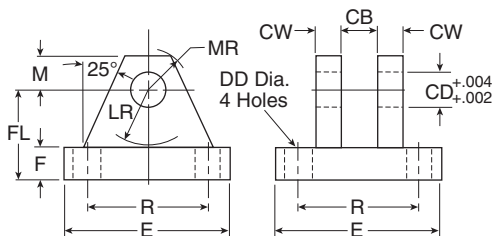

Symbol	1458050050	1458050075	1458050100	1458050138	1458050175
CB	3/4	1-1/4	1-1/2	2	2-1/2
CD	1/2	3/4	1	1-3/8	1-3/4
CW	1/2	5/8	3/4	1	1-1/4
DD	13/32	17/32	21/32	21/32	29/32
E	3-1/2	5	6-1/2	7-1/2	9-1/2
F	1/2	5/8	3/4	7/8	7/8
FL	1-1/2	1-7/8	2-1/4	3	3-5/8
LR	3/4	1-3/16	1-1/2	2	2-3/4
M	1/2	3/4	1	1-3/8	1-3/4
MR	5/8	29/32	1-1/4	1-21/32	2-7/32
R	2.55	3.82	4.95	5.73	7.50
Load Capacity (lbs)	7300	14000	19200	36900	34000



For inventory, lead times, and kit lookup, visit [www.pdnplu.com](http://www.pdnplu.com)

Mounting Plate & Eye Bracket

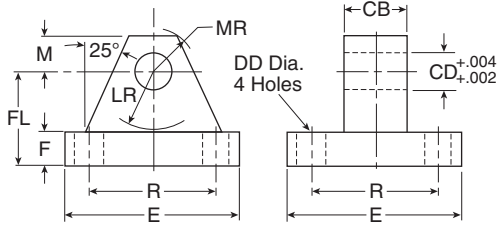

Symbol	1458060050	1458060075	1458060100	1458060138	1458060175
CB	3/4	1-1/4	1-1/2	2	2-1/2
CD	1/2	3/4	1	1-3/8	1-3/4
DD	13/32	17/32	21/32	21/32	29/32
E	2-1/2	3-1/2	4-1/2	5	6-1/2
F	3/8	5/8	7/8	7/8	1-1/8
FL	1-1/8	1-7/8	2-3/8	3	3-3/8
LR	3/4	1-1/4	1-1/2	2-1/8	2-1/4
M	1/2	3/4	1	1-3/8	1-3/4
MR	9/16	7/8	1-1/4	1-5/8	2-1/8
R	1.63	2.55	3.25	3.82	4.95
Load Capacity (lbs)	4100	10500	20400	21200	49480

1-1/2" to 8" Bore Cylinder Accessories

Rod end accessories can be selected by cylinder rod end thread size from Tables A & B below. Mating parts for rod end accessories are listed just to the right of the knuckle or clevis selected. Mounting plates for style MP1 & MP4 cylinder mounts are selected by bore size from Table C.

Rod End Thread Size	Mating Parts		
	Female Rod Clevis	Eye Bracket	Pivot Pin
7/16-20	1458030044	1458060050	0683680000
1/2-20	1458030050	1458060050	0683680000
3/4-16	1458030075	1458060075	0683690000
7/8-14	1458030088	1458060100	0683700000
1-14	1458030100	1458060100	0683700000
1-1/4-12	1458030125	1458060138	0683710000
1-1/2-12	1458030150	1458060175	0683720000

Knuckle	Mating Parts
	Clevis Bracket
1458040044	1458050050
1458040050	1458050050
1458040075	1458050075
1458040088	1458050100
1458040100	1458050100
1458040125	1458050138
1458040150	1458050175

Bore Size	Mounting Plates	
	For Mtg. Style Mp1 Cylinder	For Mtg. Style Mp4 Cylinder
1-1/2	1458060050	1458050050
2	1458060050	1458050050
2-1/2	1458060050	1458050050
3-1/4	1458060075	1458050075
4	1458060075	1458050075
5	1458060075	—
6	1458060100	—
8	1458060100	—

Pivot Pin

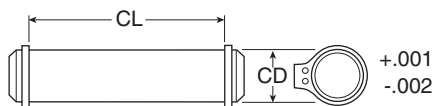

Symbol	0856640044	0683680000	0683690000	0683700000	0683710000	0683720000
CD	7/16	1/2	3/4	1	1-3/8	1-3/4
CL	1-5/16	1-7/8	2-5/8	3-1/8	4-1/8	5-3/16
Shear Cap. (lbs)	6600	8600	19300	34300	65000	105200

Note: Pivot Pin must be ordered separately for single lug pivot mounting.

Maximum pivot angle for rear clevis mounts (BB mounts) and accessories

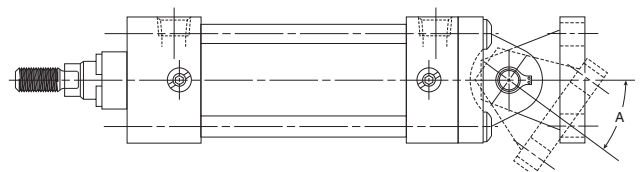

Bore	1-1/2	2	2-1/2	3-1/4	4	5	6	8
Angle A	52	43	29	50	49	45	42	42

4MAJ Series – Rod Lock

<b>B</b>	Tie Rod Pneumatic Cylinders
	4MA Series
4MAJ Series	
ACVB Option	
LPS0 Option	
P1D Series	
P1F Series	
2MNR Series	

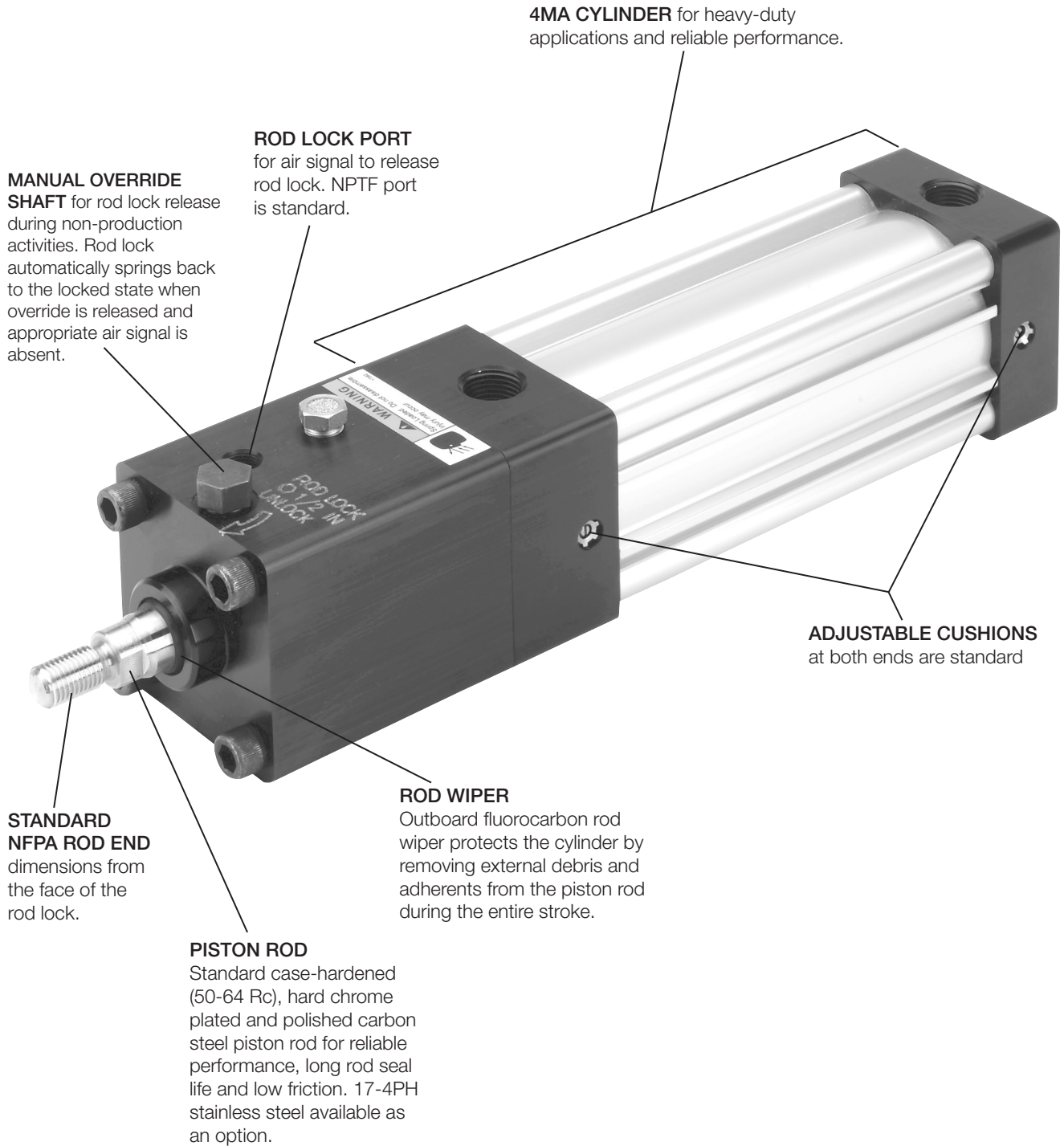



**NFPA Non-Lube Pneumatic Cylinder with Manual Override Rod Lock**

Rod lock version 4MA Series (the 4MAJ) provides precise load holding with virtually zero backlash and features high accuracy for demanding applications. The rod lock is a spring-activated type with air pressure release and clamps the piston rod to lock it into position. In the absence of an appropriate air signal, full holding force is applied to the piston rod. When a 60 PSI (or greater) air signal is present, the locking device is released. All rod locks include a manual override shaft to free the rod lock without air pressure during non-production activities.

**Some key benefits of the 4MAJ Series Cylinders**

**Bolt-On Modularity** – As a true cylinder accessory, the rod lock may be removed without affecting the base cylinder (1-1/2" to 5" bores). The same, great cylinder remains intact, allowing the rod lock to bolt-on with minimal length change. This modularity can be extremely important for special installations or while servicing the cylinder. Rod locks for 6" - 8" bores and all Style DD mounts (NFPA MT4) are fastened to the base cylinder using the base cylinder's tie rods. See drawings below.

**Aesthetics** – we have designed our rod locks with the same anodized aluminum extrusion used for the cylinder endcaps, resulting in a virtually seamless assembly. In addition, we focused every effort to create the shortest overall package, minimizing the need for customers to accommodate significantly longer cylinder lengths.

**Functionality** – With a holding force corresponding to 100 PSI on the cap end for nearly every bore size, the rod lock can be used for a variety of holding applications. The manual override shaft allows occasional release of the piston rod and automatically returns the rod lock back to the locked state when it is released and the appropriate air signal is absent. The front pilot diameter meets NFPA specifications and facilitates proper installation of the cylinder to customer equipment or cylinder accessories.

**Ease of Order Entry** – To order 4MA Series with the rod lock option, just change the product series to 4MAJ (the "J" is required for the rod lock option). See model code on page B40 for additional information.

**1-1/2" to 5" Bores**

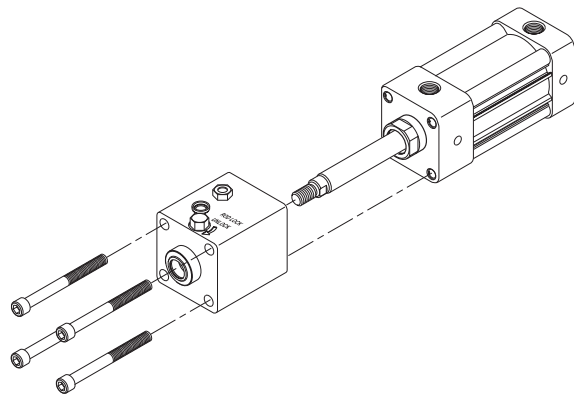

**6" to 8" Bores and all style DD mounts (NFPA MT4)**

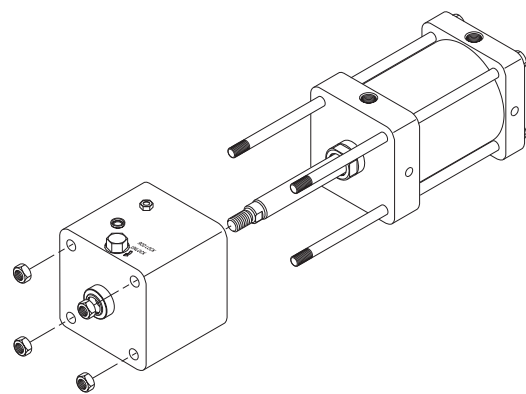

**B**

Tie Rod Pneumatic Cylinders

4MA Series

4MAJ Series

ACVB Option

LPSO Option

P1D Series

P1F Series

2MNR Series

**NFPA Non-Lube Pneumatic Cylinder with Manual Override Rod Lock**

**Connection**

The signal air for the locking device can be obtained directly from a main air supply, or from the air supply serving the valve that controls the cylinder itself. For controlled ON/OFF operation of the locking device, a separate quick-venting valve is used.

The piston rod should not be moving when the locking device is activated. The locking device is not intended to brake a movement in repeated sequences.

**NOTE:** The 4MAJ is not intended for use in water service applications, or in environments that have high humidity levels and/or splashing fluids present.

**NOTE:** Exhaust air from the rod lock can be piped away when there are demands for a contaminant-free environment.

Operation at pressures lower than 60 PSI may lead to inadvertent engagement of the rod lock device.

**Other Cylinder and Rod Lock Features:**

- The 4MAJ rod lock will operate in both directions, engaging with the same holding force.
- The 4MAJ can be mounted in any position.
- Piston rod rotation is not allowed when the rod lock is engaged (not intended for torsional braking).
- Rod lock is suitable for infrequent dynamic braking (emergency stops). Since the 4MAJ rod lock is designed for static applications, repeated dynamic stops will cause rod and/or bearing wear and reduce holding forces.
- The rated holding force corresponds to static load conditions. If the rated value is exceeded, slipping and other problems may occur.
- If personal safety is required, an unrelated, redundant safety system is recommended.

**Basic Rod Lock Specifications**

Bore size	Rod no.	Rod dia. MM	Air chamber volume (in <sup>3</sup> )	Engagement time (seconds)	Rated holding force (lbs)	Minimum torque to override (ft-lbs to hex shaft)
1-1/2	1	5/8	0.25	0.030	180	2
	2	5/8	0.71	0.040	314	5
2	3	1	0.68	0.040	250	5
	1	5/8	1.26	0.045	491	7
2-1/2	3	1	1.49	0.050	491	7
	1	1	3.20	0.070	830	17
3-1/4	3	1-3/8	2.11	0.060	830	17
	1	1	6.73	0.100	1,256	45
4	3	1-3/8	4.78	0.100	1,256	45
	1	1	11.50	0.150	1,963	72
5	3	1-3/8	9.50	0.130	1,963	72
	1	1-3/8	14.08	0.175	2,830	135
6	3	1-3/4	12.75	0.165	2,830	135
	1	1-3/8	22.66	0.265	5,026	160
8	3	1-3/4	23.21	0.265	5,026	160

**Sample Pneumatic Circuit**

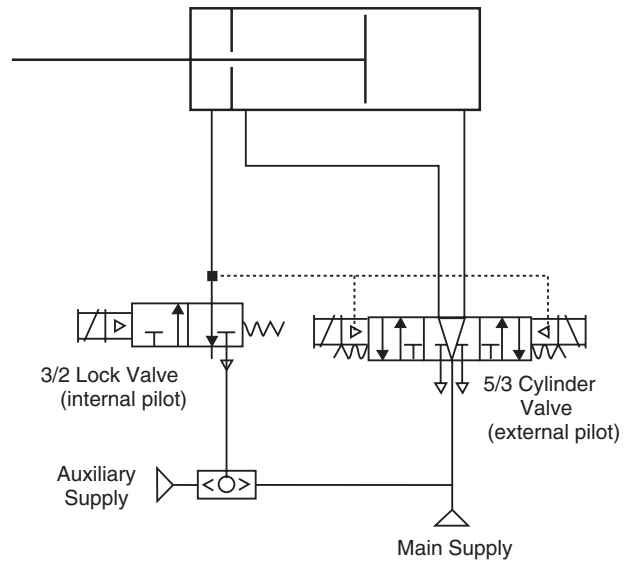

1. Lock valve must be maintained energized during cylinder motion, otherwise rod lock is engaged and cylinder valve shifts to mid position.
2. Cylinder valve must be maintained energized during extend or retract. Also keep energized at end of stroke until change of direction is desired.
3. Mid position of 5/3 Cylinder valve may be pressurized outlets if the combination of pressure load on the cylinder and inertia effects of the attached load do not exceed the holding force rating of the rod lock device, including allowance for wear.
4. Do not use cylinder lines for any logic functions – pressure levels vary too much.

**Note:** This specification data applies only to the rod lock part of the 4MAJ cylinder.

For cylinder volume and performance, please use cylinder dimensions and application criteria.

# Tie Rod Pneumatic Cylinders 4MAJ Series, Rod Lock Option

## Features

- Industry leading NFPA interchangeable rod lock cylinder with flexible construction
- Rod lock holding force equivalent to cylinder output force at 100 PSIG
- Bore sizes – 1-1/2", 2", 2-1/2", 3-1/4", 4", 5", 6" and 8"
- 17 standard styles mounting styles available
- Available in any practical stroke length
- Rod diameters – 5/8", 1", 1-3/8" and 1-3/4"
- Single rod end or double rod ends
- Adjustable cushions are standard at both ends
- Manual override feature standard on all configurations

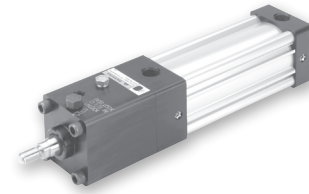

### Operating information

Operating pressure: 100 PSIG (7 bar) maximum air pressure, except 2" bore with 1" rod rated at 80 PSIG)  
60 PSIG (4.1 bar) minimum air pressure to release rod lock

Temperature range –  
Standard seals -10°F to 165°F (-23°C to 74°C)  
Fluorocarbon seals -10°F to 250°F (-23°C to 121°C)

Filtration requirements: 40 micron, dry filtered air

## Ordering information

<b>2.00</b>	<b>C</b>	<b>J</b>	<b>4MAJ</b>	<b>U</b>	<b>1</b>	<b>4</b>	<b>A</b>	<b>C</b>	<b>6.000</b>
<b>Bore Size</b>	<b>Double Rod Cylinder</b>		<b>Series</b>	<b>Ports<sup>4</sup></b>	<b>Piston Rod Number</b>		<b>Special Modification</b>	<b>Cushion Cap End</b>	<b>Stroke Length</b>
1.50 <sup>1</sup>	Specify "K" only if double rod cylinder is required.		4MAJ 4MAJ Rod Lock Cylinder	U NPTF R BSPP B BSPT T SAE	Specify rod code number for required diameter. <sup>8</sup>		Specify "S" only for special modification other than rod end, and then describe modification in item notes. (Includes 4MAJ with Linear Position Sensor Option) <sup>7</sup>	C Cushioned Cap End "C" Is Required	Specify stroke length required in inches. <sup>10</sup>
2.00									
2.50									
3.25									
4.00									
5.00									
6.00 <sup>11</sup>									
8.00 <sup>11</sup>									
<b>Cushion Head End</b>	<b>Mounting Style</b>							<b>Piston Rod Thread Type</b>	
C Cushioned Head End "C" Is Required	Specify mounting style code (see table on following page).							A Standard (UNF unified thread) W BSF British Fine M* Metric	
<b>Cylinder Construction</b>									
Blank* Standard (extruded body, standard round lobe orientation)									
A* Extruded Body, Round Lobe Orientation Rotated 90 Degrees from Standard									
N* Extruded Body, Round Lobe Orientation Rotated 180 Degrees from Standard									
Z* Extruded Body, Round Lobe Orientation Rotated 270 Degrees from Standard									
T Aluminum Round Tube and Carbon Steel Tie Rods & Nuts									
* Please reference table on page B5. Only applies to 1-1/2" to 4" bore.									
<b>Seals</b>									
Blank Standard (nitrile seals)									
V Fluorocarbon Seals <sup>5</sup>									
E Fluorocarbon Rod Wiper and Rod Seal Only <sup>6</sup>									
<b>Piston Rod Thread Style</b>									
4 Small Male									
8 Intermediate Male									
9 Short Female									
55 For Use with Split Coupler <sup>9</sup>									
3 Special (and specify all dimensions required)									
<b>Special Modification</b>									
1 Not available with 1" rod diameter (rod number 2) for 1-1/2" bore. Not available with Linear Position Sensor Option (LPSO).									
3 Addition of 1/4" bumper results in a 1/4" stroke loss per bumper, per end. For example, a 6" stroke cylinder with 1/4" bumpers at both ends (option B) has an effective stroke of 5-1/2".									
4 Port thread styles only for base cylinder. Rod lock port is always NPTF. If a different rod lock port thread style is required, place an "S" for special in the Special Modification field and indicate the desired rod lock port thread style in the item notes.									
5 Fluorocarbon seals for 4MAJ are only for external chemical compatibility applications, not high temperature.									
6 Used for external chemical compatibility applications, not high temperature.									
7 For Linear Position Sensor Option (LPSO), please include the following information for the Special Modification item notes: a. Sensor part number (please reference pages B72-B76) b. Sensor position c. Port position (if other than position 1) d. Length of stop tubing, gross stroke and net stroke (if required)									
<b>Piston Type<sup>11</sup></b>									
Blank Lipseals and Magnetic Ring (legacy)									
1 Lipseals, No Magnetic Ring (legacy)									
2 Lipseals, No Magnetic Ring (aluminum piston)									
3 Lipseals and Magnetic Ring (aluminum piston) (standard for 4ML)									
4 Bumper Seals, No Magnetic Ring									
6 Bumper Seals and Magnetic Ring									
B Lipseals, 1/4" Thick Bumpers Both Ends <sup>3</sup>									
H Lipseals, 1/4" Thick Bumper Head End <sup>3</sup>									
C Lipseals, 1/4" Thick Bumper Cap End <sup>3</sup>									
D Lipseals and Magnetic Ring, 1/4" Thick Bumpers Both Ends <sup>3</sup>									
F Lipseals and Magnetic Ring, 1/4" Thick Bumper Head End <sup>3</sup>									
R Lipseals and Magnetic Ring, 1/4" Thick Bumper Cap End <sup>3</sup>									
<b>Rod Material and Gland Code</b>									
Blank Standard Rod and Gland									
H Standard Rod and HI LOAD Gland									
Y 17-4 PH Stainless Steel Rod and Standard Gland									
Z 17-4 PH Stainless Steel Rod and HI LOAD Gland									
<b>Operating information</b>									
Operating pressure: 100 PSIG (7 bar) maximum air pressure, except 2" bore with 1" rod rated at 80 PSIG) 60 PSIG (4.1 bar) minimum air pressure to release rod lock									
Temperature range – Standard seals -10°F to 165°F (-23°C to 74°C) Fluorocarbon seals -10°F to 250°F (-23°C to 121°C)									
Filtration requirements: 40 micron, dry filtered air									
<b>Cylinder dimensions will approximate dimensions for 4MAJ. Piston Type option (blank), 3, 6, D, F or R is required. Please consult the Pneumatic Division for additional information.</b>									
<b>Review Piston Rod Selection Chart, please reference page A14 to determine proper piston rod diameter.</b>									
<b>For additional information regarding this style, please reference page B77. If non-standard Rod Material and Gland Code is required with this option, please place an "S" for special in Special Modification field and specify Rod Material and Gland Code in the item notes.</b>									
<b>If a stop tube is required, specify gross stroke (net stroke + stop tube) in the model number, then place an "S" for special in the Special Modification field and specify the stop tube length in the item notes. Not available with Piston Types (blank) and 1 for 1-1/2" - 5" bore cylinders.</b>									
<b>6"-8" bore 4MAJ can accept only Piston Types (blank) and 3. The (blank) piston for 6"-8" bores is aluminum, lipseals, no magnetic ring.</b>									

For ordering purposes, when special options or common modifications are requested, the factory will assign a sequential part number in place of the model number.



For inventory, lead times, and kit lookup, visit [www.pdnplu.com](http://www.pdnplu.com)

**Mounting Styles**

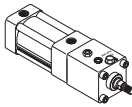
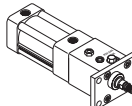
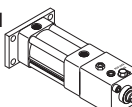
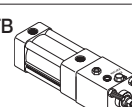
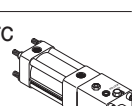
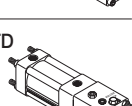
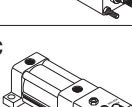
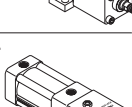
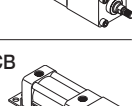
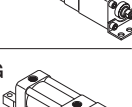
Mounting Style	Nfpa Mounting	Description	Bore Size
<b>T</b> 	MX0	No Mount	4MAJ 1-1/2 - 8 w/LPSO 2 - 8 w/LPSO w/stop tube 2 - 8
<b>J</b> 	MF1	Head Rectangular Flange	4MAJ 1-1/2 - 6 w/LPSO 2 - 6 * w/LPSO w/stop tube 2 - 6
<b>H</b> 	MF2	Cap Rectangular Flange	4MAJ 1-1/2 - 6 w/LPSO 2 - 6 * w/LPSO w/stop tube 2 - 6 *
<b>TB</b> 	MX3	Tie Rods Extended Head End	4MAJ 1-1/2 - 8 w/LPSO 2 - 6 *
<b>TC</b> 	MX2	Tie Rods Extended Cap End	4MAJ 1-1/2 - 8
<b>TD</b> 	MX1	Tie Rods Extended Both Ends	4MAJ 1-1/2 - 8
<b>C</b> 	MS2	Side Lug	4MAJ 1-1/2 - 8 w/LPSO 2 - 8 w/LPSO w/stop tube 2 - 8
<b>F</b> 	MS4	Side Tap	4MAJ 1-1/2 - 8 w/LPSO 2 - 8 w/LPSO w/stop tube 2 - 8
<b>CB</b> 	MS1	Side End Angle	4MAJ 1-1/2 - 8 w/LPSO 2 - 8 w/LPSO w/stop tube 2 - 8
<b>G</b> 	MS7	Side End Lug	4MAJ 1-1/2 - 4 w/LPSO 2 - 4 w/LPSO w/stop tube 2 - 4

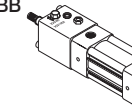
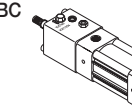
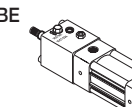
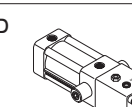
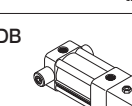
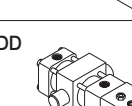
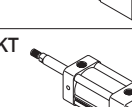
Mounting Style	Nfpa Mounting	Description	Bore Size
<b>BB</b> 	MP1	Cap Fixed Clevis	4MAJ 1-1/2 - 8 w/LPSO 2 - 8 * w/LPSO w/stop tube 2 - 8 *
<b>BC</b> 	MP2	Cap Detachable Clevis	4MAJ 1-1/2 - 8 w/LPSO 2 - 8 * w/LPSO w/stop tube 2 - 8 *
<b>BE</b> 	MP4	Cap Detachable Eye	4MAJ 1-1/2 - 6 w/LPSO 2 - 6 * w/LPSO w/stop tube 2 - 6 *
<b>D</b> 	MT1	Head Trunnion	4MAJ 1-1/2 - 8 w/LPSO 2 - 8 w/LPSO w/stop tube 2 - 8
<b>DB</b> 	MT2	Cap Trunnion	4MAJ 1-1/2 - 8 w/LPSO 2 - 8 * w/LPSO w/stop tube 2 - 8 *
<b>DD</b> 	MT4	Intermediate Trunnion	4MAJ 1-1/2 - 8
<b>KT</b> 	MDX0	Double Rod End, No Mount	4MAJ 1-1/2 - 8 w/LPSO 2 - 8 w/LPSO w/stop tube 2 - 8

\* May interfere with mounting. Please provide clearance for Linear Sensor overhang (see page B73).

**B**  
Tie Rod Pneumatic Cylinders  
4MA Series  
4MAJ Series  
ACVB Option  
LPSO Option  
P1D Series  
P1F Series  
2MNR Series

**Sensors**  
 See section L for sensors.  



For inventory, lead times, and kit lookup, visit [www.pdnplu.com](http://www.pdnplu.com)

**General Specifications**

- NFPA interchangeable\*
- Bore sizes – 1-1/2", 2", 2-1/2", 3-1/4", 4", 5", 6" and 8"
- Strokes – available in any practical stroke length
- Rod diameters – 5/8", 1", 1-3/8" and 1-3/4"
- Rod end styles – 4 standard, specials available
- Single rod end or double rod ends
- Cushions – required and adjustable at both ends
- Operating pressure –  
 100 PSIG (6.9 bar)\*\* maximum air service, except for  
 2" bore with 1" rod (rated at 80 PSIG)  
 60 PSIG (4.1 bar) minimum air pressure to release  
 rod lock

- Media – dry, filtered air
- Temperature range –  
 -10°F to 165°F (-23°C to 74°C)
- Mounting styles – 18 standard styles

\* NFPA standards do not specify rod lock cylinder dimensions. The 4MA cylinder and mounting accessories subscribe to NFPA standards.

\*\* The pressure ratings are for these devices as stated. However, the rated holding forces of the rod locks are as stated on page B62.

For material options, including seals and piston rods, please see Material Specifications on below.

**Cylinder Weights**

Bore (inch)	Rod (inch)	No Mount Single Rod		No Mount Double Rod	
		Base Wt. (lbs.)	Per inch (lbs.)	Base Wt. (lbs.)	Per Inch (lbs.)
1-1/2	0.625	4.23	0.20	4.66	0.28
	1.00	6.49	0.35	7.84	0.58
2	0.625	5.90	0.21	6.55	0.30
	1.00	6.49	0.35	7.84	0.58
2-1/2	0.625	7.75	0.23	8.46	0.31
	1.00	8.56	0.37	10.24	0.60
3-1/4	1.00	13.95	0.42	15.15	0.64
	1.375	15.93	0.62	19.46	1.05
4	1.00	20.80	0.49	22.32	0.71
	1.375	22.29	0.69	26.37	1.12
5	1.00	31.20	0.61	33.84	0.84
	1.375	32.72	0.81	36.89	1.24
6	1.375	55.50	0.87	60.63	1.30
	1.75	57.61	1.13	65.41	1.82
8	1.375	94.50	1.25	100.15	1.68
	1.75	96.63	1.51	104.90	2.20

**Mounting Weight Adders**

Bore (inch)	Weight (lbs) by Mounting Style							
	J, H	D, DB	BB	CB, G	DD	BE	C	BC
1-1/2	0.51	0.50	0.15	0.36	1.70	0.23	0.15	0.20
2	0.76	0.50	0.26	0.65	2.38	0.32	0.15	0.29
2-1/2	1.13	0.50	0.38	1.05	3.00	0.42	0.15	0.41
3-1/4	2.76	0.50	0.98	1.38	5.35	1.26	0.35	1.06
4	4.05	0.50	1.35	2.20	6.75	1.62	0.35	1.49
5	6.46	0.50	1.20	4.29	8.77	1.26	0.57	2.41
6	10.74	1.22	2.91	5.88	15.52	2.91	0.69	11.38
8	N/A	1.22	2.91	7.84	25.01	N/A	0.67	17.31

**Standard Cushion Position**

Mounting Code	Position
All except D, DB, DD	2
D, DB, DD	3

**Standard Cylinder Port Sizes**

Bore	NPTF / BSPT	BSPP	SAE
1-1/2	3/8	G3/8	6
2	3/8	G3/8	6
2-1/2	3/8	G3/8	6
3-1/4	1/2	G1/2	10
4	1/2	G1/2	10
5	1/2	G1/2	10
6	3/4	G3/4	12
8	3/4	G3/4	12

Port thread styles for base cylinder only. Rod lock port is always NPTF. If a different rod lock port thread style is required, place an "S" for special in the Special Modification field and indicate the desired rod lock port thread style in the item notes. Standard rod lock port sizes are detailed in cylinder dimension tables.

**Standard Temperatures and Applications**

Same as 4MA for 4MAJ, with the following additions/changes:

Piston rod (other materials not available)	Case-hardened, chrome plated carbon steel (standard) 17-4 PH stainless steel, chrome plated.
Rod lock housing	Black anodized aluminum alloy
Rod lock wiper	Fluorocarbon
Manual override shaft	416 stainless steel
Rod lock screws	Black oxidized steel alloy

**B**

Tie Rod Pneumatic Cylinders

4MA Series

4MAJ Series

ACVB Option

LPSO Option

P1D Series

P1F Series

2MNR Series



**How to Select a 4MAJ Cylinder**

Parker cylinders are available based on air operating pressure. The many styles, sizes and optional features available assure that your application requirements are precisely met. To select a cylinder, follow these simple steps:

- Step 1 - **Determine the correct cylinder bore size** necessary to achieve required force using the available operating pressure.
- Step 2 - **Determine the series cylinder to use**, based on operating pressure.
- Step 3 - **Turn to the appropriate cylinder selection section.** Select the mounting style that fits your installation needs. Determine the bore and rod sizes available for the model you select. Then complete model selection.
  - Choose a rod end style and the desired rod end accessories.
  - Size the cylinder to meet your application requirements.
- Step 4 - **Consider the following conditions** which may require further modifications to the cylinder you have selected.

Application Condition	Check the Following
Quick Starts or Stops	Confirm that determined thrust is sufficient to accelerate or decelerate cylinder and load within prescribed distance. Mandatory cushions can be used to reduce shock during deceleration, check that peak pressures will be within tolerable limits.
Long Push Stroke	Check whether stop tube (4MAJ with aluminum piston only) is required to prevent excessive bearing loads and wear.
High-column Loading Long Push Stroke	Determine if standard size piston rod is strong enough to accommodate intended load. See Piston Rod Selection Chart or Application Engineering section for recommendations.
Long Horizontal Stroke	Determine if standard size piston rod is strong enough to accommodate intended load.

**Options and Modifications:**

- Piston Bumper Seals
- Piston Bumpers (1/4" Thick)
- Port and Cushion Adjust Relocation
- Port Thread Styles
- Multiple Ports
- Adjustable Sensors
- Linear Position Sensing Option (LPSO)
- Double Rod End
- Rod End Modifications
- Stop Tube
- Mixed Mountings
- Shock Absorber on Cap End
- Round Tube and Tie Rod Construction
- Air Cylinder/Valve Combination (ACVB)
- Hydro-Check for smooth hydraulic control

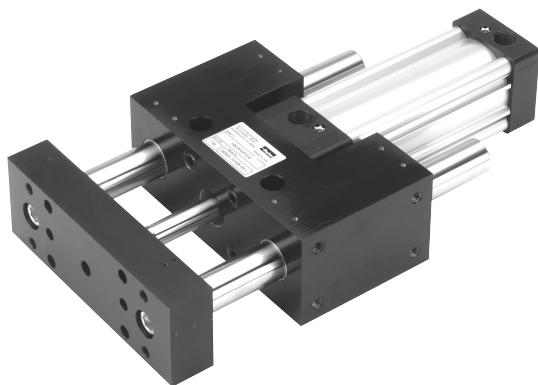

For a guided version of the 4MAJ Series, please see the HB Series in Section E.

<b>B</b>	Tie Rod Pneumatic Cylinders
	4MA Series
	4MAJ Series
	ACVB Option
	LPSO Option
	P1D Series
	P1F Series
	2MNR Series



**Single Rod**

**No Mount Basic**

Style T  
 (NFPA MX0)

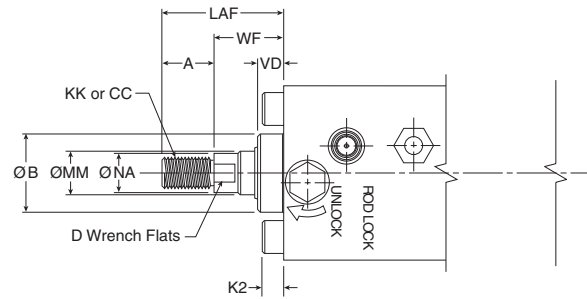
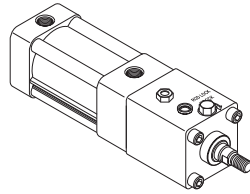

For dimensions of all standard rod end styles, see next page.

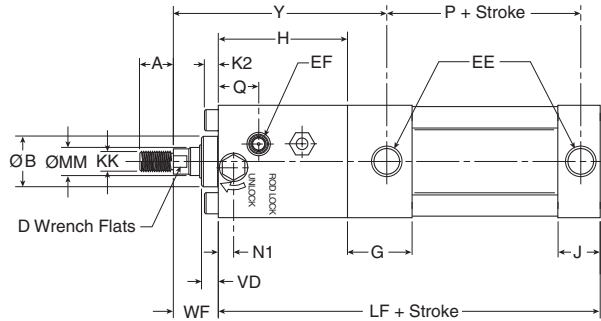
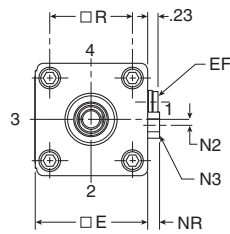

**Style T Dimensions**

Bore Size	Rod No.	Rod Dia. MM	Thread			A	AA	B	D	E	EE (NPTF)	EF (NPTF)	G	H	J
			Style 8 CC	Style 4 & 9 KK	Style 6										
1-1/2	1	5/8	1/2 - 20	7/16 - 20	5/8 - 18	0.750	2.020	1.124	1/2	2.000	3/8	1/8	1.438	2.625	0.938
	3	1	7/8 - 14	3/4 - 16	1 - 14	1.125	2.600	1.499	7/8	2.500	3/8	1/8	1.375	3.875	0.937
2	1	5/8	1/2 - 20	7/16 - 20	5/8 - 18	0.750	2.600	1.124	1/2	2.500	3/8	1/8	1.375	2.875	0.937
	3	1	7/8 - 14	3/4 - 16	1 - 14	1.125	2.600	1.499	7/8	2.500	3/8	1/8	1.375	3.875	0.937
2-1/2	1	5/8	1/2 - 20	7/16 - 20	5/8 - 18	0.750	3.100	1.124	1/2	3.000	3/8	1/8	1.344	2.875	0.938
	3	1	7/8 - 14	3/4 - 16	1 - 14	1.125	3.100	1.499	7/8	3.000	3/8	1/8	1.344	4.000	0.938
3-1/4	1	1	7/8 - 14	3/4 - 16	1 - 14	1.125	3.900	1.499	7/8	3.750	1/2	1/4	1.594	4.500	1.125
	3	1-3/8	1-1/4 - 12	1 - 14	1-3/8 - 14	1.625	3.900	1.999	1-1/8	3.750	1/2	1/4	1.594	4.875	1.125
4	1	1	7/8 - 14	3/4 - 16	1 - 14	1.125	4.700	1.499	7/8	4.500	1/2	1/4	1.594	4.875	1.125
	3	1-3/8	1-1/4 - 12	1 - 14	1-3/8 - 14	1.625	4.700	1.999	1-1/8	4.500	1/2	1/4	1.594	5.125	1.125
5	1	1	7/8 - 14	3/4 - 16	1 - 14	1.125	5.800	1.499	7/8	5.500	1/2	1/4	1.594	5.375	1.219
	3	1-3/8	1-1/4 - 12	1 - 14	1-3/8 - 14	1.625	5.800	1.999	1-1/8	5.500	1/2	1/4	1.594	5.750	1.219

Bore Size	Rod No.	Rod Dia. MM	K2	LAF	N1	N2	Hex N3	NA	NR	Q	R	VD	WF	Y	Add stroke	
															LF	P
1-1/2	1	5/8	0.250	1.750	0.220	0.140	5/16	0.563	0.190	0.715	1.430	0.375	1.000	4.500	6.250	2.313
	3	1	0.313	2.500	0.338	0.146	1/2	0.938	0.275	1.065	1.840	0.500	1.375	6.125	7.500	2.313
2	1	5/8	0.313	1.750	0.340	0.130	1/2	0.563	0.265	0.895	1.840	0.375	1.000	4.750	6.500	2.313
	3	1	0.313	2.500	0.338	0.146	1/2	0.938	0.265	1.120	2.190	0.500	1.375	6.313	7.750	2.313
2-1/2	1	5/8	0.313	1.750	0.346	0.150	1/2	0.563	0.265	0.755	2.190	0.500	1.000	4.813	6.625	2.375
	3	1	0.313	2.500	0.346	0.148	1/2	0.938	0.265	1.120	2.190	0.500	1.375	6.313	7.750	2.375
3-1/4	1	1	0.375	2.500	0.631	0.180	5/8	0.938	0.340	1.510	2.760	0.500	1.375	6.938	8.750	2.625
	3	1-3/8	0.375	3.250	0.813	0.247	5/8	1.313	0.350	1.645	2.760	0.625	1.625	7.563	9.125	2.625
4	1	1	0.375	2.500	0.625	0.240	7/8	0.938	0.500	1.725	3.320	0.500	1.375	7.313	9.125	2.625
	3	1-3/8	0.375	3.250	0.771	0.276	7/8	1.313	0.490	1.679	3.320	0.750	1.625	7.813	9.375	2.625
5	1	1	0.500	2.500	0.720	0.220	7/8	0.938	0.500	1.995	4.100	0.500	1.375	7.813	9.875	2.875
	3	1-3/8	0.500	3.250	0.720	0.220	7/8	1.313	0.490	2.330	4.100	0.750	1.625	8.438	10.250	2.875

**B**

Tie Rod Pneumatic Cylinders

4MA Series

4MAJ Series

ACVB Option

LPSO Option

P1D Series

P1F Series

2MNR Series



For inventory, lead times, and kit lookup, visit [www.pdnplu.com](http://www.pdnplu.com)



**Rod End**

**Thread Style 4**  
(NFPA Style SM)  
Small Male

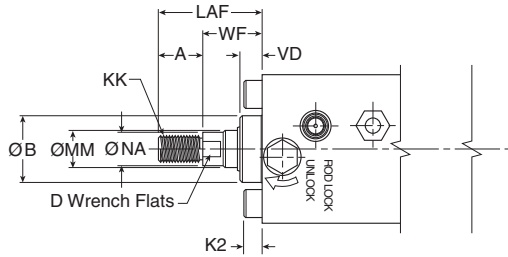

**Thread Style 8**  
(NFPA Style IM)  
Intermediate Male

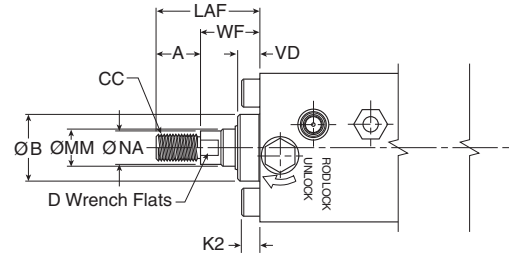

**Thread Style 9**  
(NFPA Style SF)  
Short Female

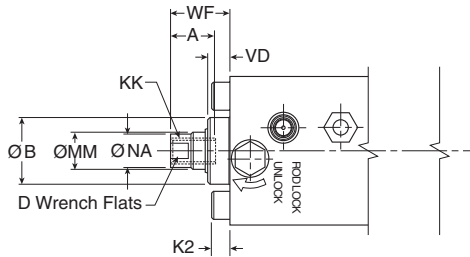

**Thread Style 55**  
For use with Split Coupler  
(please reference page B77 for more information)

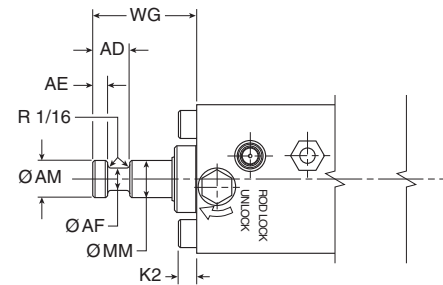

**Thread Style 3 - "Special Thread"**

Special threads, rod extensions, rod eyes, blanks, etc. are also available. To order, specify "Style 3" and give desired dimensions for KK or CC, A and W or WF. If otherwise special, please supply dimensioned sketch.

**Rod End Dimensions**

Bore Size	Rod No.	Rod Dia. MM	Thread			A	AD	AE	AF	AM	B	D	K2	LAF	NA	VD	WF	WG
			Style 8 CC	Style 4 & 9 KK	Style 6													
1-1/2	1	5/8	1/2 - 20	7/16 - 20	5/8 - 18	0.750	0.625	0.250	0.375	0.570	1.124	1/2	0.250	1.750	0.563	0.375	1.000	1.750
	2	5/8	1/2 - 20	7/16 - 20	5/8 - 18	0.750	0.625	0.250	0.375	0.570	1.124	1/2	0.313	1.750	0.563	0.375	1.000	1.750
	3	1	7/8 - 14	3/4 - 16	1 - 14	1.125	0.938	0.375	0.688	0.950	1.499	7/8	0.313	2.500	0.938	0.500	1.375	2.375
2-1/2	1	5/8	1/2 - 20	7/16 - 20	5/8 - 18	0.750	0.625	0.250	0.375	0.570	1.124	1/2	0.313	1.750	0.563	0.500	1.000	1.750
	3	1	7/8 - 14	3/4 - 16	1 - 14	1.125	0.938	0.375	0.688	0.950	1.499	7/8	0.313	2.500	0.938	0.500	1.375	2.375
3-1/4	1	5/8	1/2 - 20	7/16 - 20	5/8 - 18	0.750	0.625	0.250	0.375	0.570	1.124	1/2	0.313	1.750	0.563	0.500	1.000	1.750
	3	1-3/8	1-1/4 - 12	1 - 14	1-3/8 - 14	1.625	1.063	0.375	0.875	1.320	1.999	1-1/8	0.375	3.250	1.313	0.625	1.625	2.750
4	1	5/8	1/2 - 20	7/16 - 20	5/8 - 18	0.750	0.625	0.250	0.375	0.570	1.124	1/2	0.313	1.750	0.563	0.500	1.000	1.750
	3	1-3/8	1-1/4 - 12	1 - 14	1-3/8 - 14	1.625	1.063	0.375	0.875	1.320	1.999	1-1/8	0.375	3.250	1.313	0.750	1.625	2.750
5	1	5/8	1/2 - 20	7/16 - 20	5/8 - 18	0.750	0.625	0.250	0.375	0.570	1.124	1/2	0.313	1.750	0.563	0.500	1.000	1.750
	3	1-3/8	1-1/4 - 12	1 - 14	1-3/8 - 14	1.625	1.063	0.375	0.875	1.320	1.999	1-1/8	0.500	2.500	0.938	0.500	1.375	2.375



For inventory, lead times, and kit lookup, visit [www.pdnplu.com](http://www.pdnplu.com)

**B**  
Tie Rod Pneumatic Cylinders  
Series 4MA  
Series 4MAJ  
Option ACVB  
Option LPSO  
Series P1D  
Series P1F  
Series 2MNR

## K-type Cylinder

To determine dimensions for a double rod end cylinder, first refer to the desired single rod end mounting style cylinder shown in this catalog section. After selecting the necessary dimensions from that drawing, return to this page and supplement the single rod end dimensions with those shown in the drawings and dimension table below. Note that double rod end cylinders have a head dimension G at both ends,

## Tie Rod Pneumatic Cylinders 4MAJ Series – 1-1/2" to 5" Bore Size

and that LG replaces LF, P<sub>k</sub> replaces P, etc. The double rod end dimensions differ from, or are in addition to, those for single rod cylinders.

When a double rod end cylinder has two different rod ends, please clearly state which rod end is to be available at which head end.

### K-type 1-1/2" to 5" Bore Size

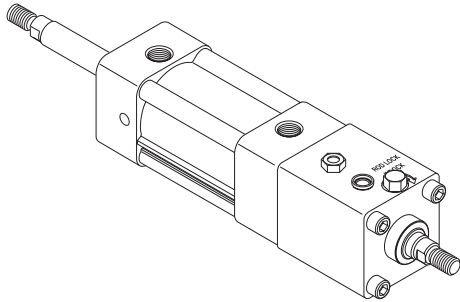

Mounting styles for single rod models	Corresponding mounting styles for double rod models
C	KC
CB	KCB
D	KD
DD	KDD
F	KF
G	KG
J	KJ
T	KT
TB	KTB
TD	KTD

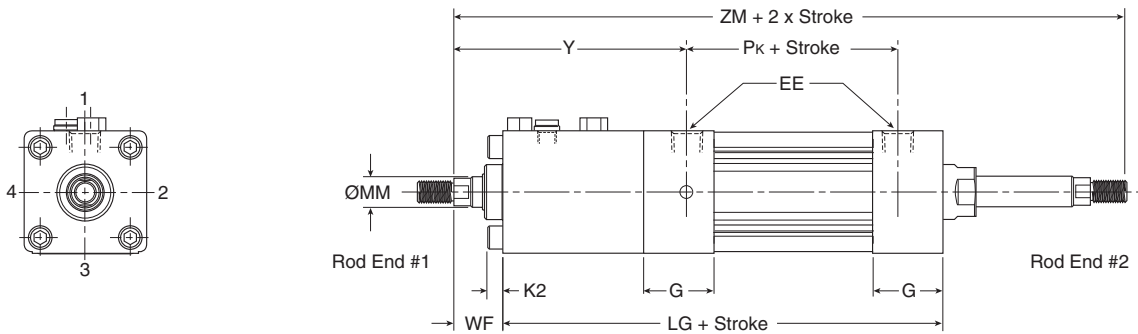

Double rod cylinders not available with composite piston type.

### Style KT Dimensions

Bore Size	Rod No.	Rod Dia. MM	EE (NPTF)	G	K2	WF	Y	Add Stroke								ZM
								LG	Pk	SAk	XAk	SSk	SNk	SEk	XEk	
1-1/2	1	5/8	3/8	1.438	0.250	1.000	4.500	6.750	2.375	8.750	8.750	3.375	2.250	9.000	8.875	8.750
	2	5/8	3/8	1.375	0.313	1.000	4.750	7.000	2.375	9.000	9.000	3.375	2.250	9.625	9.313	9.000
2	3	1	3/8	1.375	0.313	1.375	6.125	8.000	2.375	10.000	10.375	3.375	2.250	10.625	10.688	10.750
	1	5/8	3/8	1.344	0.313	1.000	4.813	7.125	2.375	9.125	9.125	3.500	2.375	10.000	9.563	9.125
2-1/2	3	1	3/8	1.344	0.313	1.375	6.313	8.250	2.375	10.250	10.625	3.500	2.375	11.125	11.063	11.000
	1	1	1/2	1.594	0.375	1.375	6.938	9.250	2.625	11.750	11.875	3.750	2.625	12.250	12.125	12.000
3-1/4	3	1-3/8	1/2	1.594	0.375	1.625	7.563	9.625	2.625	12.125	12.500	3.750	2.625	12.625	12.750	12.875
	1	1	1/2	1.594	0.375	1.375	7.313	9.625	2.625	12.125	12.250	3.750	2.625	12.875	12.625	12.375
4	3	1-3/8	1/2	1.594	0.375	1.625	7.813	9.875	2.625	12.375	12.750	3.750	2.625	13.125	13.125	13.125
	1	1	1/2	1.594	0.500	1.375	7.813	10.313	2.813	13.063	13.063	3.563	2.813	-	-	13.063
5	3	1-3/8	1/2	1.594	0.500	1.625	8.438	10.688	2.813	13.438	13.688	3.563	2.813	-	-	13.938
	Replaces Dimension								LF	P	SA	XA	SS	SN	SE	XE
On Single Rod Mounting Styles								All Styles	All Styles	CB	CB	C	F	G	G	All

**B**

Tie Rod Pneumatic Cylinders

4MA Series

4MAJ Series

ACVB Option

LPSO Option

P1D Series

P1F Series

2MNR Series



For inventory, lead times, and kit lookup, visit [www.pdnplu.com](http://www.pdnplu.com)

B45

Parker Hannifin Corporation  
Pneumatic Division  
Wadsworth, Ohio  
[www.parker.com/pneumatics](http://www.parker.com/pneumatics)

**Head Rectangular Flange**

Style J  
(NFPA MF1)

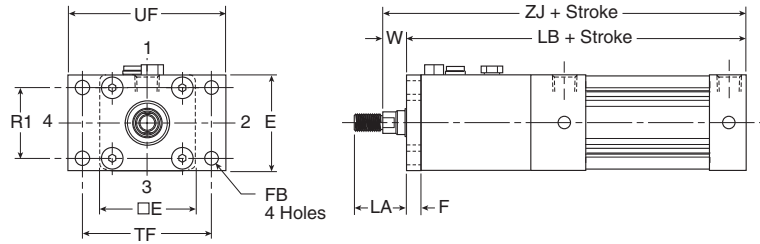
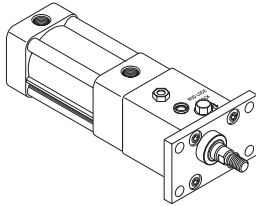

**Note:** Style J has a W dimension instead of WF and a LA dimension instead of LAF because of the flange installation. Please use dimensions W and LA regarding rod ends only for Style J. For reference,  $WF = W + F$  and  $LA = W + A$ .

**Cap Rectangular Flange**

Style H  
(NFPA MF2)

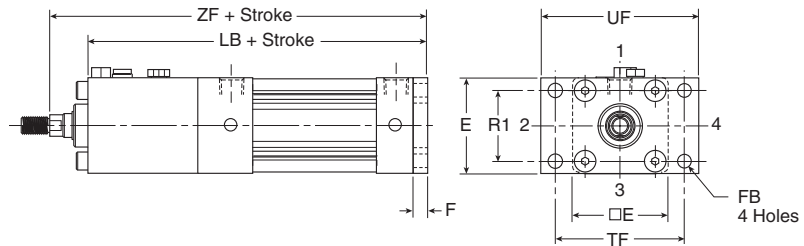
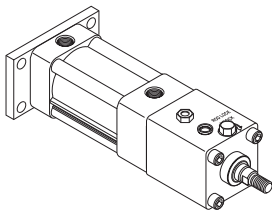

**Styles J and H Dimensions**

Bore Size	Rod No.	Rod Dia. MM	A	E	F	FB	LA	R1	TF	UF	W	Add stroke		
												LB	ZF	ZJ
1-1/2	1	5/8	0.750	2.000	0.375	0.313	1.375	1.430	2.750	3.375	0.625	6.625	7.625	7.250
	3	1	1.125	2.500	0.375	0.375	1.375	1.840	3.375	4.125	0.625	6.875	7.875	7.500
2	1	5/8	0.750	3.000	0.375	0.375	1.375	2.190	3.875	4.625	0.625	7.000	8.000	7.625
	3	1	1.125	3.000	0.375	0.375	2.125	2.190	3.875	4.625	1.000	8.125	9.500	8.125
2-1/2	1	5/8	0.750	3.750	0.625	0.438	1.875	2.760	4.688	5.500	0.750	9.375	10.750	10.125
	3	1-3/8	1.625	3.750	0.625	0.438	2.625	2.760	4.688	5.500	1.000	9.750	11.375	10.750
3-1/4	1	1	1.125	4.500	0.625	0.438	1.875	3.320	5.438	6.250	0.750	9.750	11.125	10.500
	3	1-3/8	1.625	4.500	0.625	0.438	2.625	3.320	5.438	6.250	1.000	10.000	11.625	11.000
4	1	1	1.125	5.500	0.625	0.563	1.875	4.100	6.625	7.625	0.750	10.500	11.875	11.250
	3	1-3/8	1.625	5.500	0.625	0.563	2.625	4.100	6.625	7.625	1.000	10.875	12.500	11.875

**B**  
Tie Rod Pneumatic  
Cylinders

4MA  
Series

4MAJ  
Series

ACVB  
Option

LP50  
Option

P1D  
Series

P1F  
Series

2MNR  
Series



For inventory, lead times, and kit lookup, visit [www.pdnplu.com](http://www.pdnplu.com)

**Tie Rods Extended Head End Mount**

Style TB  
 (NFFPA MX3)

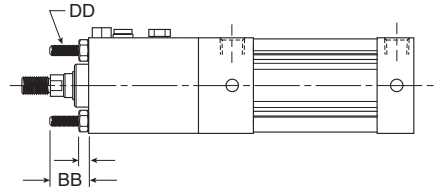
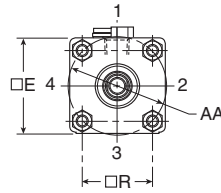
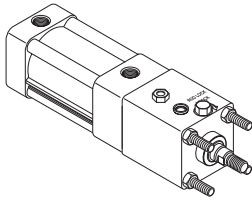

**Tie Rods Extended Cap End Mount**

Style TC  
 (NFFPA MX2)

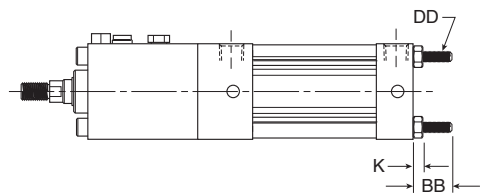
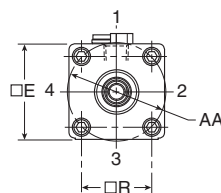
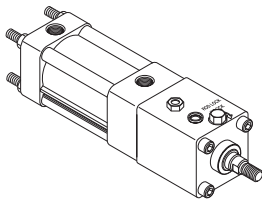

**Tie Rods Extended Both Ends Mount**

Style TD  
 (NFFPA MX1)

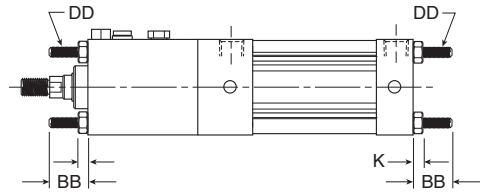
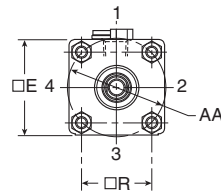
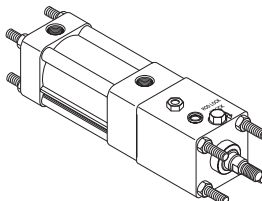

**Styles TB, TC and TD Dimensions**

Bore Size	Rod No.	Rod Dia. MM	AA	BB	DD	E	K	R
1-1/2	1	5/8	2.020	1.000	1/4 - 28	2.000	0.250	1.430
	3	1	2.600	1.125	5/16 - 24	2.500	0.313	1.840
2	1	5/8	2.600	1.125	5/16 - 24	2.500	0.313	1.840
	3	1	3.100	1.125	5/16 - 24	3.000	0.313	2.190
2-1/2	1	5/8	3.100	1.125	5/16 - 24	3.000	0.313	2.190
	3	1	3.900	1.375	3/8 - 24	3.750	0.375	2.760
3-1/4	1	1	3.900	1.375	3/8 - 24	3.750	0.375	2.760
	3	1-3/8	4.700	1.375	3/8 - 24	4.500	0.375	3.320
4	1	1	4.700	1.375	3/8 - 24	4.500	0.375	3.320
	3	1-3/8	5.800	1.813	1/2 - 20	5.500	0.438	4.100
5	1	1	5.800	1.813	1/2 - 20	5.500	0.438	4.100
	3	1-3/8						

**B**

Tie Rod Pneumatic Cylinders

4MA Series

4MAJ Series

ACVB Option

LPSO Option

P1D Series

P1F Series

2MNR Series



For inventory, lead times, and kit lookup, visit [www.pdnplu.com](http://www.pdnplu.com)

**Style C, F**

**Tie Rod Pneumatic Cylinders  
4MAJ Series – 1-1/2” to 5” Bore Size**

**Side Lug Mount**

Style C  
(NFPA MS2)

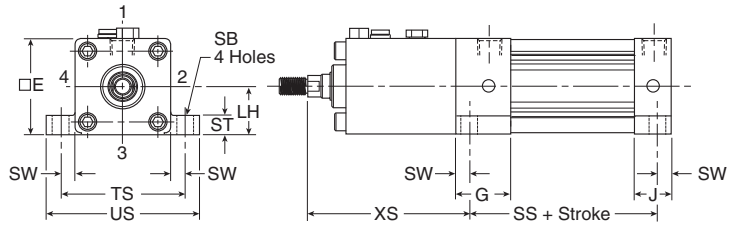
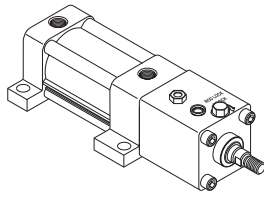

**Style C Dimensions**

Bore Size	Rod No.	Rod Dia. MM	E	G	J	+/- .003 LH	SB	ST	SW	TS	US	XS	Add Stroke SS	
1-1/2	1	5/8	2.000	1.438	0.938	0.993	0.438	0.500	0.375	2.750	3.500	4.000	2.875	
	2	1	5/8	2.500	1.375	0.937	1.243	0.438	0.500	0.375	3.250	4.000	4.250	2.875
		3	1	2.500	1.375	0.937	1.243	0.438	0.500	0.375	3.250	4.000	5.625	2.875
2-1/2	1	5/8	3.000	1.344	0.938	1.493	0.438	0.500	0.375	3.750	4.500	4.250	3.000	
	3	1	3.000	1.344	0.938	1.493	0.438	0.500	0.375	3.750	4.500	5.750	3.000	
3-1/4	1	1	3.750	1.594	1.125	1.868	0.563	0.750	0.500	4.750	5.750	6.375	3.250	
	3	1-3/8	3.750	1.594	1.125	1.868	0.563	0.750	0.500	4.750	5.750	7.000	3.250	
4	1	1	4.500	1.594	1.125	2.243	0.563	0.750	0.500	5.500	6.500	6.750	3.250	
	3	1-3/8	4.500	1.594	1.125	2.243	0.563	0.750	0.500	5.500	6.500	7.250	3.250	
5	1	1	5.500	1.594	1.219	2.743	0.813	1.000	0.688	6.875	8.250	7.438	3.125	
	3	1-3/8	5.500	1.594	1.219	2.743	0.813	1.000	0.688	6.875	8.250	8.063	3.125	

**Side Tap Mount**

Style F  
(NFPA MS4)

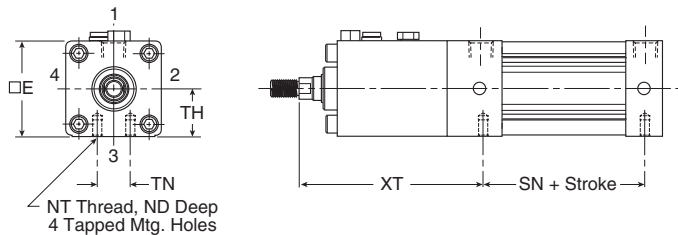
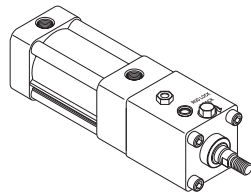

**Style F Dimensions**

Bore Size	Rod No.	Rod Dia. MM	E	ND	NT	+/- .003 TH	TN	XT	Add Stroke SN
1-1/2	1	5/8	2.000	0.375	1/4 - 20	0.993	0.625	4.563	2.250
	2	1	5/8	2.500	0.438	5/16 - 18	1.243	0.875	4.813
3		1	2.500	0.375	5/16 - 18	1.243	0.875	6.188	2.250
2-1/2	1	5/8	3.000	0.625	3/8 - 16	1.493	1.250	4.813	2.375
	3	1	3.000	0.625	3/8 - 16	1.493	1.250	6.313	2.375
3-1/4	1	1	3.750	0.750	1/2 - 13	1.868	1.500	6.938	2.625
	3	1-3/8	3.750	0.750	1/2 - 13	1.868	1.500	7.563	2.625
4	1	1	4.500	0.750	1/2 - 13	2.243	2.063	7.313	2.625
	3	1-3/8	4.500	0.750	1/2 - 13	2.243	2.063	7.813	2.625
5	1	1	5.500	0.938	5/8 - 11	2.743	2.688	7.813	2.875
	3	1-3/8	5.500	0.938	5/8 - 11	2.743	2.688	8.438	2.875

**B** Tie Rod Pneumatic Cylinders

4MA Series

4MAJ Series

ACVB Option

LPSO Option

P1D Series

P1F Series

2MNR Series



For inventory, lead times, and kit lookup, visit [www.pdnplu.com](http://www.pdnplu.com)

**Side End Angle Mount**

Style CB  
(NFPA MS1)

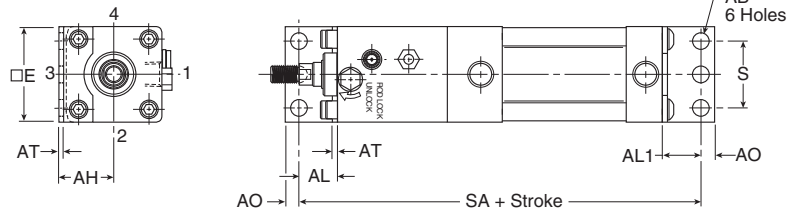
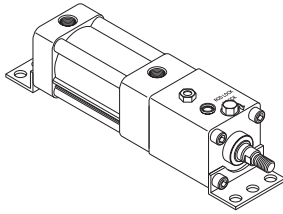

**Style CB Dimensions**

Bore Size	Rod No.	Rod Dia. MM	AB	AH	AL	AL1	AO	AT	E	S	Add Stroke
											SA
1-1/2	1	5/8	0.438	1.188	1.000	1.000	0.375	0.125	2.000	1.250	8.250
	3	1	0.438	1.438	1.000	1.000	0.375	0.125	2.500	1.750	8.500
2	1	5/8	0.438	1.438	1.000	1.000	0.375	0.125	2.500	1.750	8.500
	3	1	0.438	1.438	1.000	1.000	0.375	0.125	2.500	1.750	9.500
2-1/2	1	5/8	0.438	1.625	1.000	1.000	0.375	0.125	3.000	2.250	8.625
	3	1	0.438	1.625	1.000	1.000	0.375	0.125	3.000	2.250	9.750
3-1/4	1	1	0.563	1.938	1.250	1.250	0.500	0.125	3.750	2.750	11.250
	3	1-3/8	0.563	1.938	1.250	1.250	0.500	0.125	3.750	2.750	11.625
4	1	1	0.563	2.250	1.875	1.250	0.500	0.125	4.500	3.500	12.250
	3	1-3/8	0.563	2.250	1.875	1.250	0.500	0.125	4.500	3.500	12.500
5	1	1	0.688	2.750	1.375	1.375	0.625	0.188	5.500	4.250	12.625
	3	1-3/8	0.688	2.750	1.375	1.375	0.625	0.188	5.500	4.250	13.000

**Side End Lug Mount**

Style G  
(NFPA MS7)

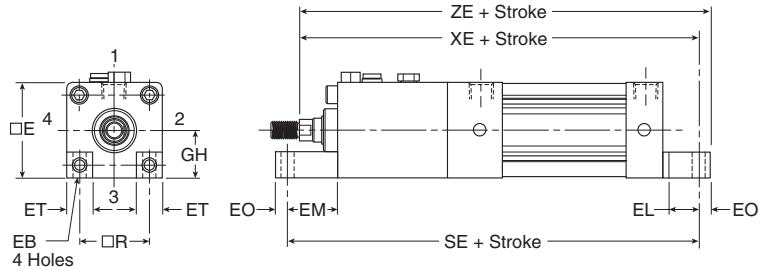
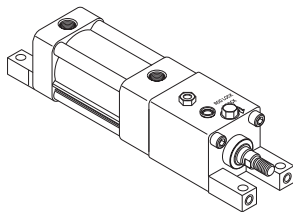

**Style G Dimensions**

Bore Size	Rod No.	Rod Dia. MM	E	EB	EL	EM	EO	ET	+/- .003 GH R	Add Stroke			
										SE	XE	ZE	
1-1/2	1	5/8	2.000	0.281	0.750	1.125	0.250	0.563	0.993	1.430	8.125	8.000	8.250
	3	1	2.500	0.344	0.938	1.313	0.313	0.688	1.243	1.840	8.750	8.438	8.750
2	1	5/8	2.500	0.344	0.938	1.313	0.313	0.688	1.243	1.840	9.750	9.813	10.125
	3	1	2.500	0.344	0.938	1.313	0.313	0.688	1.243	1.840	9.750	9.813	10.125
2-1/2	1	5/8	3.000	0.344	1.063	1.438	0.313	0.813	1.493	2.190	9.125	8.688	9.000
	3	1	3.000	0.344	1.063	1.438	0.313	0.813	1.493	2.190	10.250	10.188	10.500
3-1/4	1	1	3.750	0.406	0.875	1.500	0.375	1.000	1.868	2.760	11.125	11.000	11.375
	3	1-3/8	3.750	0.406	0.875	1.500	0.375	1.000	1.868	2.760	11.500	11.625	12.000
4	1	1	4.500	0.406	1.000	1.625	0.375	1.188	2.243	3.320	11.750	11.500	11.875
	3	1-3/8	4.500	0.406	1.000	1.625	0.375	1.188	2.243	3.320	12.000	12.000	12.375

**B**

Tie Rod Pneumatic Cylinders

4MA Series

4MAJ Series

ACVB Option

LPSO Option

P1D Series

P1F Series

2MNR Series



For inventory, lead times, and kit lookup, visit [www.pdnplu.com](http://www.pdnplu.com)

**Cap Fixed Clevis Mount**

Style BB  
 (NFPA MP1)

**NOTE:** For maximum swivel angle of BB mount with rear mounting plate, please reference cylinder accessories on page B80.

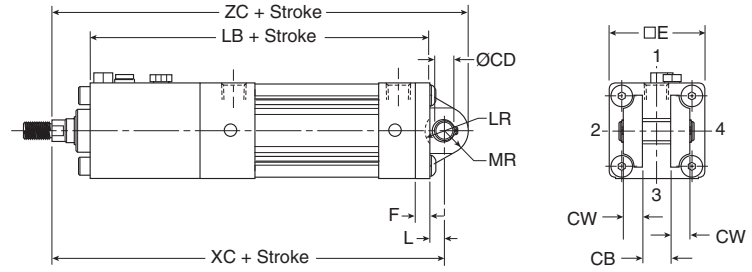
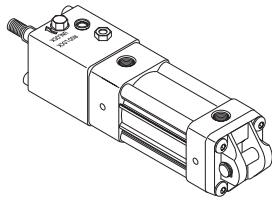

**Cap Detachable Clevis Mount**

Style BC  
 (NFPA MP2)

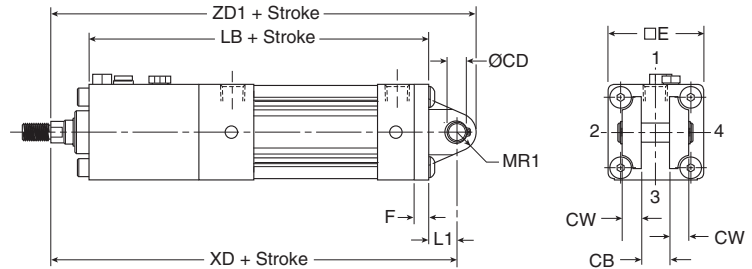
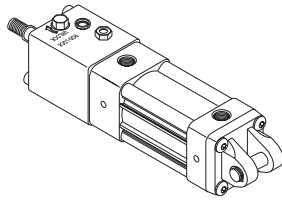

**Styles BB and BC Dimensions**

Bore Size	Rod No.	Rod Dia. MM	CB	+0.000 -0.002 CD	CW	E	F	L	L1	LR	MR	MR1	Add Stroke				
													LB	XC	XD	ZC	ZD1
1-1/2	1	5/8	0.750	0.501	0.500	2.000	0.375	0.375	0.750	0.750	0.625	0.500	6.625	8.000	8.375	8.625	8.875
	1	5/8	0.750	0.501	0.500	2.500	0.375	0.375	0.750	0.750	0.625	0.500	6.875	8.250	8.625	8.875	9.125
	3	1	0.750	0.501	0.500	2.500	0.375	0.375	0.750	0.750	0.625	0.500	7.875	9.625	10.000	10.250	10.500
2-1/2	1	5/8	0.750	0.501	0.500	3.000	0.375	0.375	0.750	0.750	0.625	0.500	7.000	8.375	8.750	9.000	9.250
	3	1	0.750	0.501	0.500	3.000	0.375	0.375	0.750	0.750	0.625	0.500	8.125	9.875	10.250	10.500	10.750
3-1/4	1	1	1.250	0.751	0.625	3.750	0.625	0.625	1.250	1.000	0.938	0.750	9.375	11.375	12.000	12.313	12.750
	3	1-3/8	1.250	0.751	0.625	3.750	0.625	0.625	1.250	1.000	0.938	0.750	9.750	12.000	12.625	12.938	13.375
4	1	1	1.250	0.751	0.625	4.500	0.625	0.625	1.250	1.000	0.938	0.750	9.750	11.750	12.375	12.688	13.125
	3	1-3/8	1.250	0.751	0.625	4.500	0.625	0.625	1.250	1.000	0.938	0.750	10.000	12.250	12.875	13.188	13.625
5	1	1	1.250	0.751	0.625	5.500	0.625	0.625	1.250	1.000	0.938	0.750	10.500	12.500	13.125	13.438	13.875
	3	1-3/8	1.250	0.751	0.625	5.500	0.625	0.625	1.250	1.000	0.938	0.750	10.875	13.125	13.750	14.063	14.500



**Cap Detachable Eye Mount**

Style BE  
 (NFPA MP4)

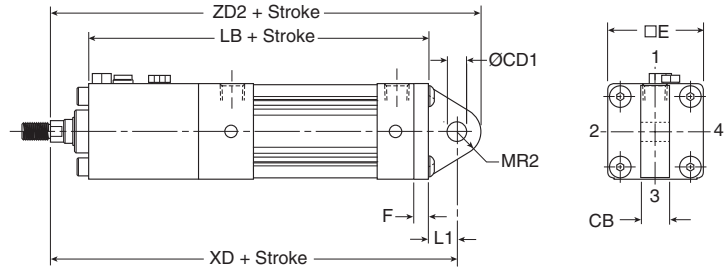
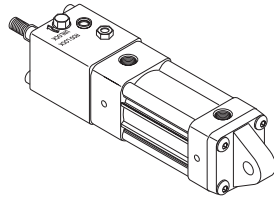

**Style BE Dimensions**

Bore Size	Rod No.	Rod Dia. MM	CB	Rod Dia. +.002 +.004 CD1	E	F	L1	MR2	Add Stroke		
									LB	XD	ZD2
1-1/2	1	5/8	0.750	0.500	2.000	0.375	0.750	0.625	6.625	8.375	9.000
	3	1	0.750	0.500	2.500	0.375	0.750	0.625	7.875	10.000	10.625
2	1	5/8	0.750	0.500	2.500	0.375	0.750	0.625	6.875	8.625	9.250
	3	1	0.750	0.500	2.500	0.375	0.750	0.625	7.875	10.000	10.625
2-1/2	1	5/8	0.750	0.500	3.000	0.375	0.750	0.688	7.000	8.750	9.438
	3	1	0.750	0.500	3.000	0.375	0.750	0.688	8.125	10.250	10.938
3-1/4	1	1	1.250	0.750	3.750	0.625	1.250	0.875	9.375	12.000	12.875
	3	1-3/8	1.250	0.750	3.750	0.625	1.250	0.875	9.750	12.625	13.500
4	1	1	1.250	0.750	4.500	0.625	1.250	0.875	9.750	12.375	13.250
	3	1-3/8	1.250	0.750	4.500	0.625	1.250	0.875	10.000	12.875	13.750
5*	1	1	1.250	0.750	5.500	0.625	1.250	0.875	10.500	13.125	14.000
	3	1-3/8	1.250	0.750	5.500	0.625	1.250	0.875	10.875	13.750	14.625

**Intermediate Trunnion Mount**

Style DD  
 (NFPA MT4)

**Note:** Tie rod nuts for Style DD have a slot instead of external hex.

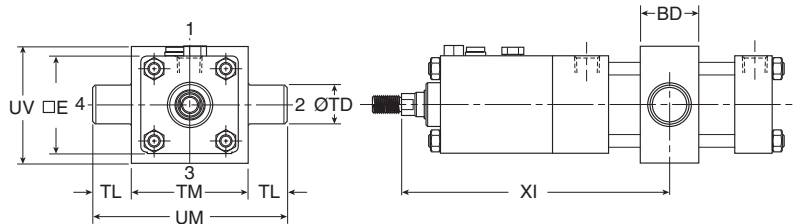
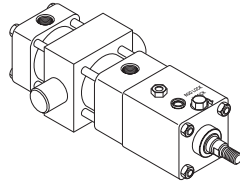

**Note:** Style DD requires minimum stroke per table.

**Style DD Dimensions**

Bore Size	Rod No.	Rod Dia. MM	E	BD	Rod Dia. +.000 -.001 TD	TL	TM	UM	UV	Min. XI	Min. Stroke
2	1	5/8	2.500	1.500	1.000	1.000	3.000	5.000	3.000	6.00	4.000
	3	1	2.500	1.500	1.000	1.000	3.000	5.000	3.000	7.38	4.000
2-1/2	1	5/8	3.000	1.500	1.000	1.000	3.500	5.500	3.500	5.97	3.875
	3	1	3.000	1.500	1.000	1.000	3.500	5.500	3.500	7.47	3.875
3-1/4	1	1	3.750	2.000	1.000	1.000	4.500	6.500	4.250	8.469	4.375
	3	1-3/8	3.750	2.000	1.000	1.000	4.500	6.500	4.250	9.094	4.375
4	1	1	4.500	2.000	1.000	1.000	5.250	7.250	5.000	8.844	4.875
	3	1-3/8	4.500	2.000	1.000	1.000	5.250	7.250	5.000	9.344	4.875
5	1	1	5.500	2.000	1.000	1.000	6.250	8.250	6.000	9.344	5.125
	3	1-3/8	5.500	2.000	1.000	1.000	6.250	8.250	6.000	9.969	5.125

**B**  
 Tie Rod Pneumatic Cylinders  
 4MA Series  
 4MAJ Series  
 ACVB Option  
 LPSO Option  
 P1D Series  
 P1F Series  
 2MNR Series



For inventory, lead times, and kit lookup, visit [www.pdnplu.com](http://www.pdnplu.com)

**Head Trunnion Mount**

Style D  
 (NFPA MT1)

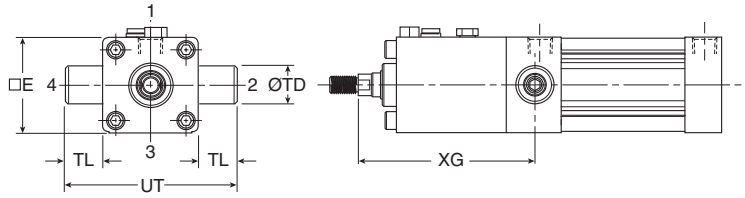
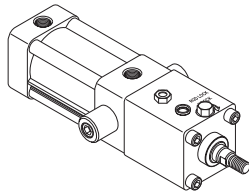

**Cap Trunnion Mount**

Style DB  
 (NFPA MT2)

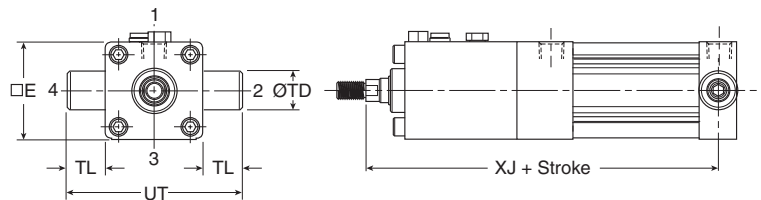
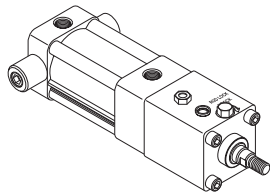

**Styles D and DB Dimensions**

Bore Size	Rod No.	Rod Dia. MM	E	+0.000 -0.001 TD	TL	UT	XG	XJ
1-1/2	1	5/8	2.000	1.000	1.000	4.000	4.375	6.750
	1	5/8	2.500	1.000	1.000	4.500	4.625	7.000
	3	1	2.500	1.000	1.000	4.500	6.000	8.375
2-1/2	1	5/8	3.000	1.000	1.000	5.000	4.625	7.125
	3	1	3.000	1.000	1.000	5.000	6.125	8.625
3-1/4	1	1	3.750	1.000	1.000	5.750	6.750	9.500
	3	1-3/8	3.750	1.000	1.000	5.750	7.375	10.125
4	1	1	4.500	1.000	1.000	6.500	7.125	9.875
	3	1-3/8	4.500	1.000	1.000	6.500	7.625	10.375
5	1	1	5.500	1.000	1.000	7.500	7.625	10.625
	3	1-3/8	5.500	1.000	1.000	7.500	8.250	11.250

**B**  
Tie Rod Pneumatic Cylinders

4MA Series

4MAJ Series

ACVB Option

LP50 Option

P1D Series

P1F Series

2MNR Series



For inventory, lead times, and kit lookup, visit [www.pdnplu.com](http://www.pdnplu.com)

**Style T**

**Tie Rod Pneumatic Cylinders  
4MAJ Series – 6” to 8” Bore Sizes**

**No Mount**

Style T  
(NFPA MX0)

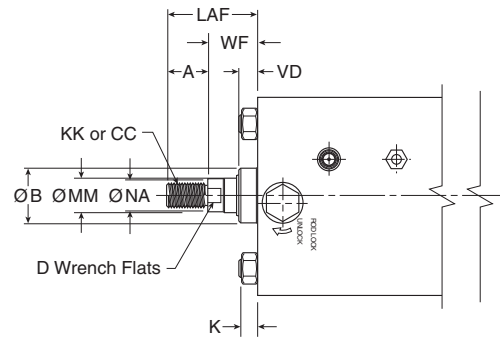
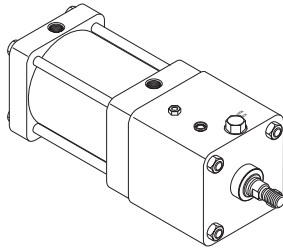

For dimensions of all standard rod end styles, see next page.

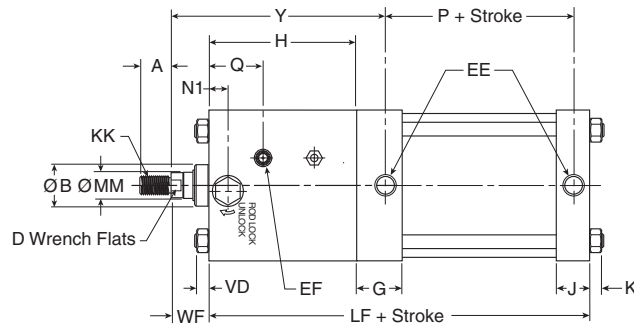
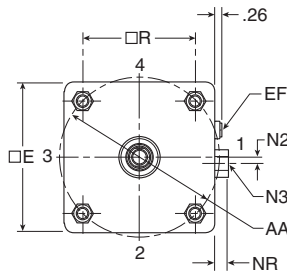

**Style T Dimensions**

Bore Size	Rod No.	Rod Dia. MM	Thread			Style 6	A	AA	B	D	E	EE (NPTF)	EF (NPTF)	G	H	J
			Style 8 CC	Style 4 & 9 KK	Style 4 & 9 CC											
6	1	1-3/8	1-1/4 - 12	1 - 14	1-3/8 - 14	1.625	6.900	1.999	1-1/8	6.500	3/4	1/4	1.910	6.375	1.410	
	3	1-3/4	1-1/2 - 12	1-1/4 - 12	1-3/4 - 12	2.000	6.900	2.374	1-1/2	6.500	3/4	1/4	1.910	6.875	1.410	
8	1	1-3/8	1-1/4 - 12	1 - 4	1-3/8 - 14	1.625	9.100	1.999	1-1/8	8.500	3/4	1/4	1.810	6.625	1.440	
	3	1-3/4	1-1/2 - 12	1-1/4 - 12	1-3/4 - 12	2.000	9.100	2.374	1-1/2	8.500	3/4	1/4	1.810	7.125	1.440	

Bore Size	Rod No.	Rod Dia. MM	Head Dimensions												Add stroke	
			K	LAF	N1	N2	Hex N3	NA	NR	Q	R	VD	WF	Y	LF	P
6	1	1-3/8	0.438	3.250	1.165	0.177	1-5/16	1.313	0.750	2.705	4.880	0.755	1.625	9.188	11.375	3.125
	3	1-3/4	0.438	3.875	1.495	0.177	1-5/16	1.688	0.740	3.055	4.880	0.875	1.875	9.938	11.875	3.125
8	1	1-3/8	0.563	3.250	1.305	0.177	1-5/16	1.313	0.740	2.885	6.440	0.755	1.625	9.375	11.750	3.250
	3	1-3/4	0.563	3.875	1.570	0.177	1-5/16	1.688	0.740	3.145	6.440	0.875	1.875	10.125	12.250	3.250

<b>B</b>	Tie Rod Pneumatic Cylinders
	4MA Series
4MAJ Series	
ACVB Option	
LPSO Option	
P1D Series	
P1F Series	
2MNR Series	



For inventory, lead times, and kit lookup, visit [www.pdnplu.com](http://www.pdnplu.com)

**Rod End**

**Thread Style 4**

(NFPA Style SM)  
Small Male

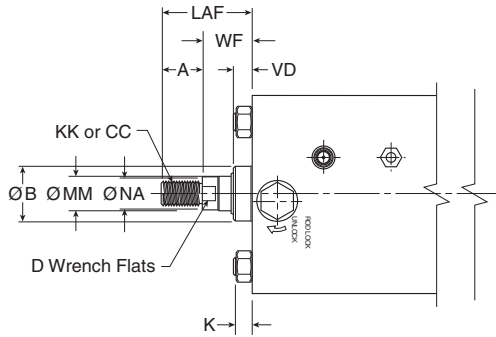

**Thread Style 8**

(NFPA Style IM)  
Intermediate Male

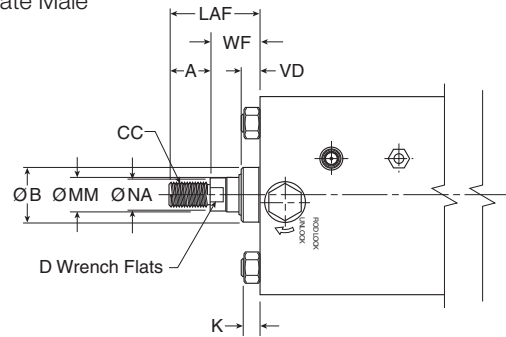

**Thread Style 9**

(NFPA Style SF)  
Short Female

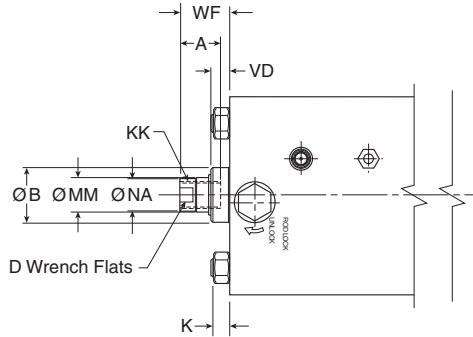

**Thread Style 55**

For use with Split Coupler  
(please reference page B77 for more information)

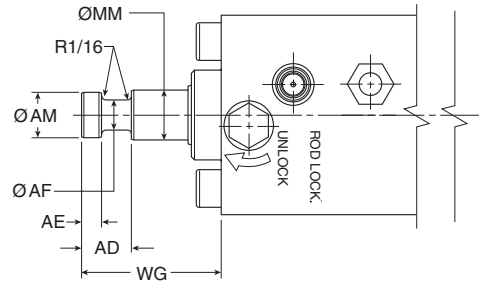

**Thread Style 3 - "Special Thread"**

Special threads, rod extensions, rod eyes, blanks, etc. are also available.  
To order, specify "Style 3" and give desired dimensions for KK or CC, A and W or WF.  
If otherwise special, please supply dimensioned sketch.

**Rod End Dimensions**

Bore Size	Rod No.	Rod Dia. MM	Thread		Style 6	A	AD	AE	AF	AM	B	D	K	LAF	NA	VD	WF	WG
			Style 8 CC	Style 4 & 9 KK														
6	1	1-3/8	1-1/4 - 12	1 - 14	1-3/8 - 14	1.625	1.063	0.375	0.875	1.320	1.999	1-1/8	0.438	3.250	1.313	0.755	1.625	2.750
	3	1-3/4	1-1/2 - 12	1-1/4 - 12	1-3/4 - 12	2.000	1.313	0.500	1.125	1.700	2.374	1-1/2	0.438	3.875	1.688	0.875	1.875	3.125
8	1	1-3/8	1-1/4 - 12	1 - 14	1-3/8 - 14	1.625	1.063	0.375	0.875	1.320	1.999	1-1/8	0.563	3.250	1.313	0.755	1.625	2.750
	3	1-3/4	1-1/2 - 12	1-1/4 - 12	1-3/4 - 12	2.000	1.313	0.500	1.125	1.700	2.374	1-1/2	0.563	3.875	1.688	0.875	1.875	3.125



For inventory, lead times, and kit lookup, visit [www.pdnplu.com](http://www.pdnplu.com)

**B**  
Tie Rod Pneumatic Cylinders  
4MA Series  
4MAJ Series  
ACVB Option  
LP50 Option  
P1D Series  
P1F Series  
2MNR Series

## K-type Cylinder

To determine dimensions for a double rod end cylinder, first refer to the desired single rod end mounting style cylinder shown in this catalog section. After selecting the necessary dimensions from that drawing, return to this page and supplement the single rod end dimensions with those shown in the drawings and dimension table below. Note that double rod end cylinders have a head dimension G at both ends, and

## Tie Rod Pneumatic Cylinders 4MAJ Series – 6” to 8” Bore Sizes

that LG replaces LF, PK replaces P, etc. The double rod end dimensions differ from, or are in addition to, those for single rod cylinders.

When a double rod end cylinder has two different rod ends, please clearly state which rod end is to be available at which head end.

### K-type 6" to 8" Bore Size

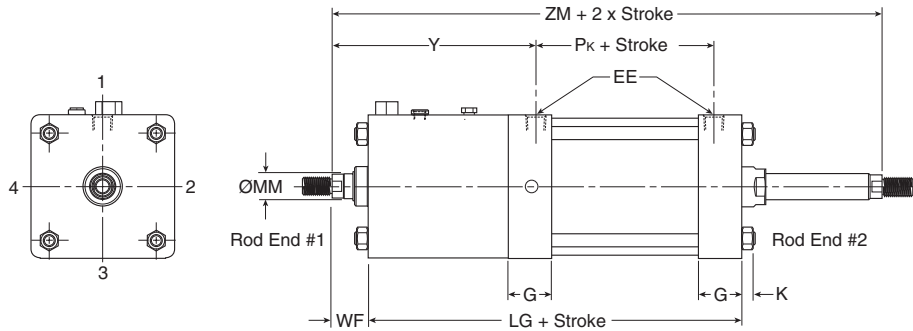
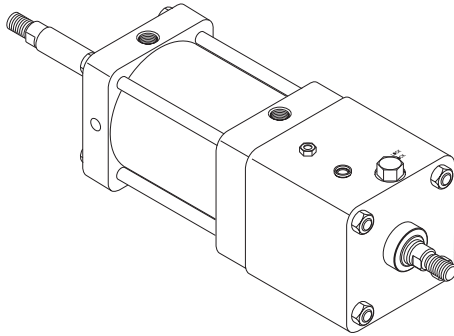

Mounting styles for single rod models	Corresponding mounting styles for double rod models
C	KC
CB	KCB
D	KD
DD	KDD
F	KF
J	KJ
T	KT
TB	KTB
TD	KTD

### Style KT Dimensions

Bore Size	Rod No.	Rod Dia. MM	EE (NPTF) G	K	WF	Y	Add Stroke						Add 2X Stroke ZM	
							LG	Pk	SAk	XAk	SSk	SNk		
6	1	1-3/8	3/4	1.910	0.438	1.625	9.188	11.875	3.125	14.625	14.875	4.125	3.125	15.125
	3	1-3/4	3/4	1.910	0.438	1.875	9.938	12.375	3.125	15.125	15.625	4.125	3.125	16.125
8	1	1-3/8	3/4	1.810	0.563	1.625	9.375	12.125	3.250	15.750	15.563	4.125	3.125	15.375
	3	1-3/4	3/4	1.810	0.563	1.875	10.125	12.625	3.250	16.250	16.313	4.125	3.125	16.375
Replaces Dimension On								LF	P	SA	XA	SS	SN	-
Single Rod Mounting Styles								All Styles	All Styles	CB	CB	C	F	All

**B**

Tie Rod Pneumatic Cylinders

4MA Series

4MAJ Series

ACVB Option

LPSO Option

P1D Series

P1F Series

2MNR Series



For inventory, lead times, and kit lookup, visit [www.pdnplu.com](http://www.pdnplu.com)

**Style J, H**

**Tie Rod Pneumatic Cylinders  
4MAJ Series – 6" to 8" Bore Sizes**

**Head Rectangular Flange Mount**

Style J  
(NFFA MF1)  
(only 6" Bore)

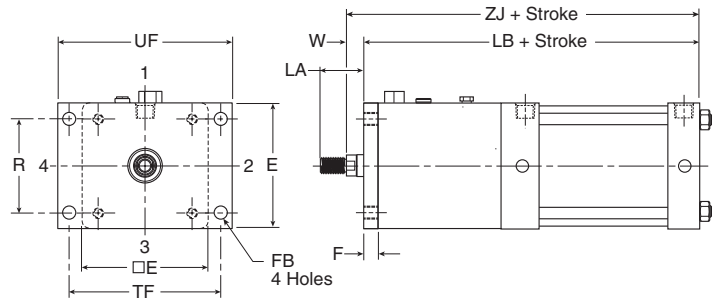
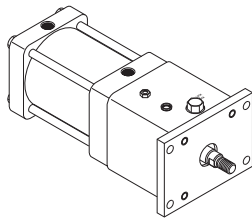

**Note:** Style J has a W dimension instead of WF and a LA dimension instead of LAF because of the flange installation. Please use dimensions W and LA regarding rod ends only for Style J.  
For reference,  $WF = W + F$  and  $LA = W + A$ .

**Cap Rectangular Flange Mount**

Style H  
(NFFA MF2)  
(only 6" Bore)

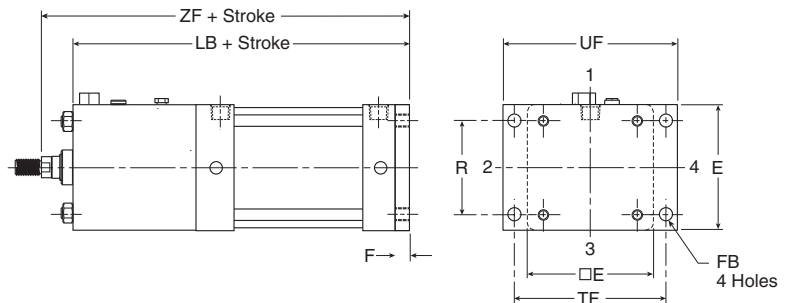
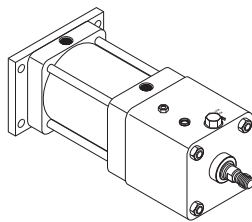

**Styles J and H Dimensions**

Bore Size	Rod No.	Rod Dia. MM											Add Stroke		
			A	E	F	FB	LA	R	TF	UF	W	LB	ZF	ZJ	
6	1	1-3/8	1.625	6.500	0.750	0.563	2.500	4.880	7.625	8.625	0.875	12.125	13.750	13.000	
	3	1-3/4	2.000	6.500	0.750	0.563	3.125	4.880	7.625	8.625	1.125	12.625	14.500	13.750	

**B**  
Tie Rod Pneumatic Cylinders  
4MA Series  
4MAJ Series  
ACVB Option  
LP50 Option  
P1D Series  
P1F Series  
2MNR Series



For inventory, lead times, and kit lookup, visit [www.pdnplu.com](http://www.pdnplu.com)

**Tie Rods Extended Head End Mount**

Style TB  
 (NFA MX3)

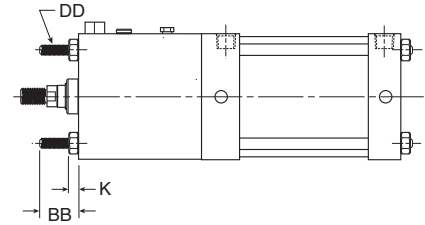
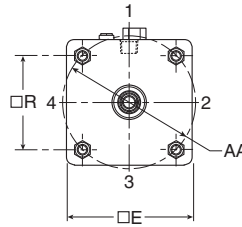
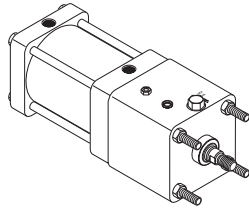

**Tie Rods Extended Cap End Mount**

Style TC  
 (NFA MX2)

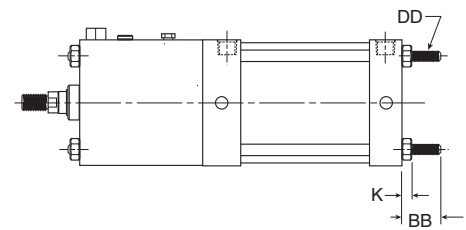
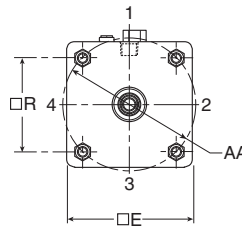
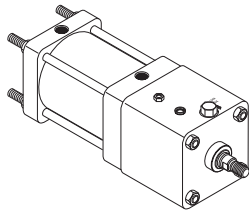

**Tie Rods Extended Both Ends Mount**

Style TD  
 (NFA MX1)

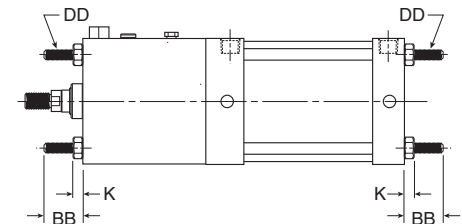
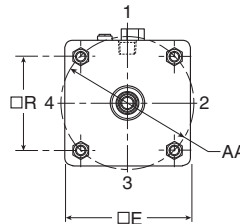
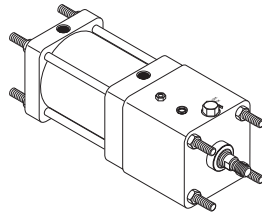

**Styles TB, TC and TD Dimensions**

Bore Size	Rod No.	Rod Dia. MM	AA	BB	DD	E	K	R
6	1	1-3/8	6.900	1.813	1/2-20	6.500	0.438	4.880
	3	1-3/4	6.900	1.813	1/2-20	6.500	0.438	4.880
8	1	1-3/8	9.100	2.313	5/8-18	8.500	0.563	6.440
	3	1-3/4	9.100	2.313	5/8-18	8.500	0.563	6.440

**B**

Tie Rod Pneumatic Cylinders

4MA Series

4MAJ Series

ACVB Option

LPSO Option

P1D Series

P1F Series

2MNR Series



For inventory, lead times, and kit lookup, visit [www.pdnplu.com](http://www.pdnplu.com)



**Side End Angle Mount**

Style CB  
 (NFPA MS1)

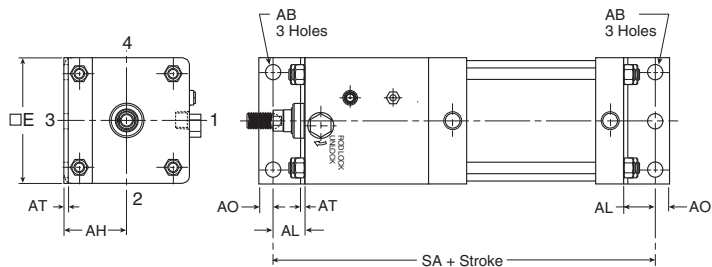
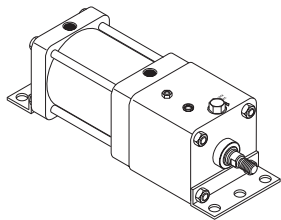

**Style CB Dimensions**

Bore Size	Rod No.	Rod Dia. MM	AB	AH	AL	AO	AT	E	S	Add Stroke SA
6	1	1-3/8	0.813	3.250	1.375	0.625	0.188	6.500	5.250	14.125
	3	1-3/4	0.813	3.250	1.375	0.625	0.188	6.500	5.250	14.625
8	1	1-3/8	0.813	4.250	1.813	0.688	0.250	8.500	7.125	15.375
	3	1-3/4	0.813	4.250	1.813	0.688	0.250	8.500	7.125	15.875

**Side Tap Mount**

Style F  
 (NFPA MS4)

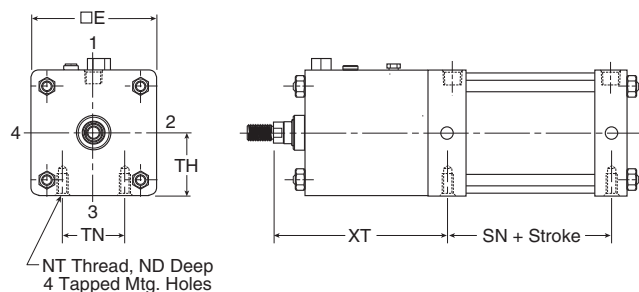
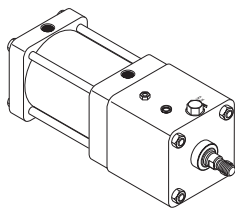

**Style F Dimensions**

Bore Size	Rod No.	Rod Dia. MM	E	ND	NT	+/- .003 TH	TN	XT	Add Stroke SN
6	1	1-3/8	6.500	1.125	3/4-10	3.243	3.250	9.188	3.125
	3	1-3/4	6.500	1.125	3/4-10	3.243	3.250	9.938	3.125
8	1	1-3/8	8.500	1.125	3/4-10	4.243	4.500	9.438	3.250
	3	1-3/4	8.500	1.125	3/4-10	4.243	4.500	10.188	3.250

**Side Lug Mount**

Style C  
 (NFPA MS2)

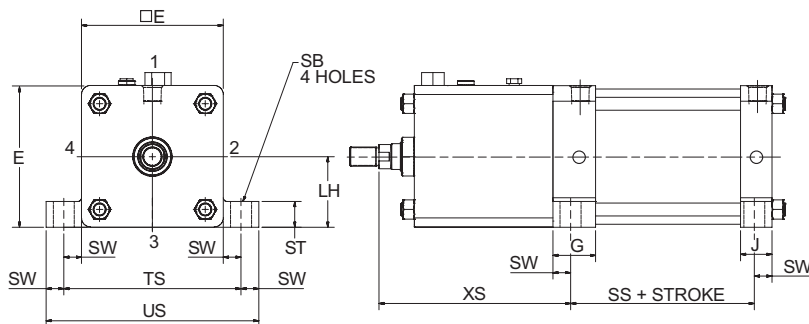
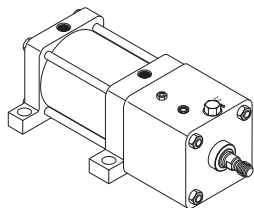

**Style C Dimensions**

Bore Size	Rod No.	Rod Dia. MM	E	G	J	+/- .003 LH	SB	ST	SW	TS	US	XS	Add Stroke SS
6	1	1-3/8	6.500	1.910	1.410	3.243	0.813	1.000	0.688	7.875	9.250	8.688	3.625
	3	1-3/4	6.500	1.910	1.410	3.243	0.813	1.000	0.688	7.875	9.250	9.438	3.625
8	1	1-3/8	8.500	1.810	1.440	4.243	0.813	1.000	0.688	9.875	11.250	8.938	3.750
	3	1-3/4	8.500	1.810	1.440	4.243	0.813	1.000	0.688	9.875	11.250	9.688	3.750

**B**  
 Tie Rod Pneumatic Cylinders  
 4MA Series  
 4MAJ Series  
 ACVB Option  
 LPSO Option  
 P1D Series  
 P1F Series  
 2MNR Series



For inventory, lead times, and kit lookup, visit [www.pdnplu.com](http://www.pdnplu.com)

**Cap Fixed Clevis**

Style BB  
 (NFPA MP1)

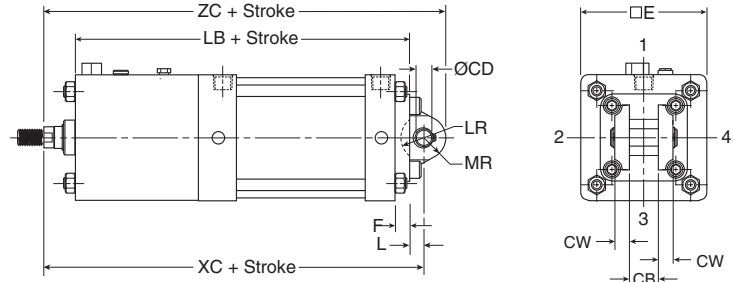
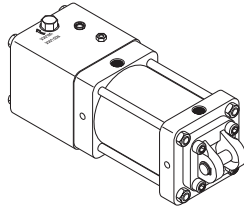

**NOTE:** For maximum swivel angle of BB mount with rear mounting plate, please reference cylinder accessories on page B80.

**Cap Detachable Clevis**

Style BC  
 (NFPA MP2)

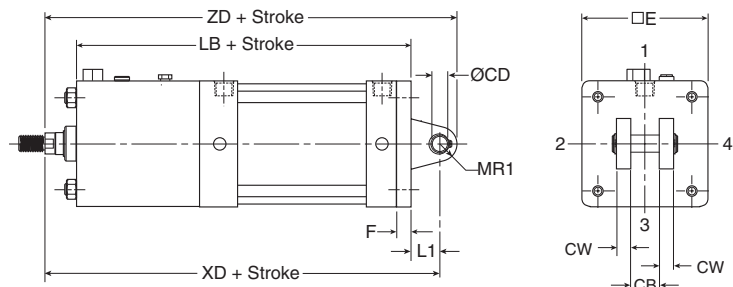
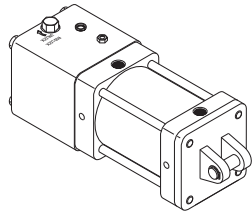

**Styles BB and BC Dimensions**

Bore Size	Rod No.	Rod Dia. MM	CB	Rod Dia. +.000 -0.002 CD	CW	E	F	L	L1	LR	MR	MR1	Add Stroke LB	XC	XD	ZC	ZD
6	1	1-3/8	1.500	1.001	0.750	6.500	0.750	0.750	1.500	1.250	1.125	1.000	12.125	14.500	15.250	15.625	16.250
	3	1-3/4	1.500	1.001	0.750	6.500	0.750	0.750	1.500	1.250	1.125	1.000	12.625	15.250	16.000	16.375	17.000
8	1	1-3/8	1.500	1.001	0.750	8.500	0.750	0.750	1.500	1.250	1.125	1.000	12.500	14.875	15.625	16.000	16.625
	3	1-3/4	1.500	1.001	0.750	8.500	0.750	0.750	1.500	1.250	1.125	1.000	13.000	15.625	16.375	16.750	17.375

**Cap Detachable Eye Mount**

Style BE  
 (NFPA MP4)  
 (only 6" Bore)

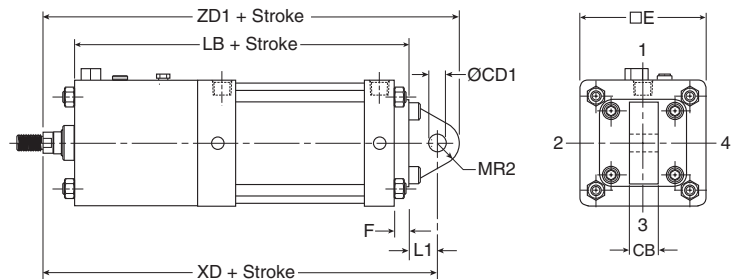
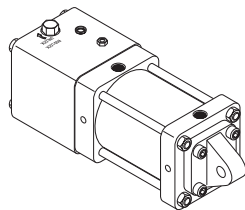

**Style BE Dimensions**

Bore Size	Rod No.	Rod Dia. MM	CB	Rod Dia. +.002 -0.004 CD1	E	F	L1	MR2	Add Stroke LB	XD	ZD1
6	1	1-3/8	1.500	1.000	6.500	0.750	1.500	1.125	12.125	15.250	16.375
	3	1-3/4	1.500	1.000	6.500	0.750	1.500	1.125	12.625	16.000	17.125

**B**

Tie Rod Pneumatic Cylinders

4MA Series

4MAJ Series

ACVB Option

LPSO Option

P1D Series

P1F Series

2MNR Series



For inventory, lead times, and kit lookup, visit [www.pdnplu.com](http://www.pdnplu.com)

**Head Trunnion Mount**

Style D  
 (NFPA MT1)

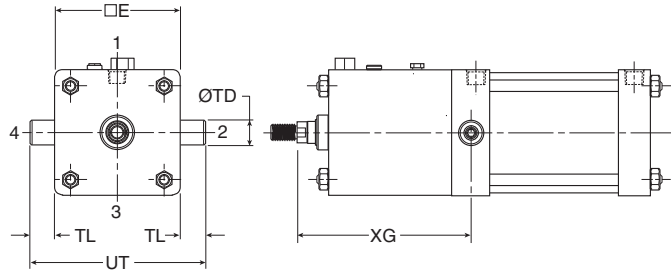
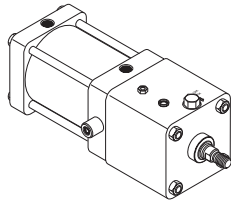

**Cap Trunnion Mount**

Style DB  
 (NFPA MT2)

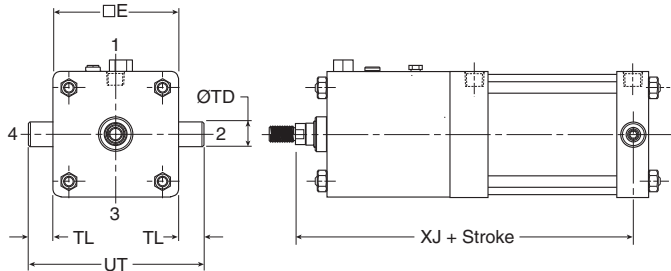
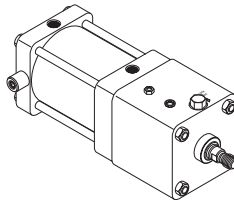

**Styles D and DB Dimensions**

Bore Size	Rod No.	Rod Dia. MM	E	TD		TL	UT	XG	XJ
				+0.000	-0.001				
6	1	1-3/8	6.500	1.375	1.375	1.375	9.250	9.000	12.250
	3	1-3/4	6.500	1.375	1.375	1.375	9.250	9.750	13.000
8	1	1-3/8	8.500	1.375	1.375	1.375	11.250	9.250	12.625
	3	1-3/4	8.500	1.375	1.375	1.375	11.250	10.000	13.375

**Intermediate Trunnion Mount**

Style DD  
 (NFPA MT4)

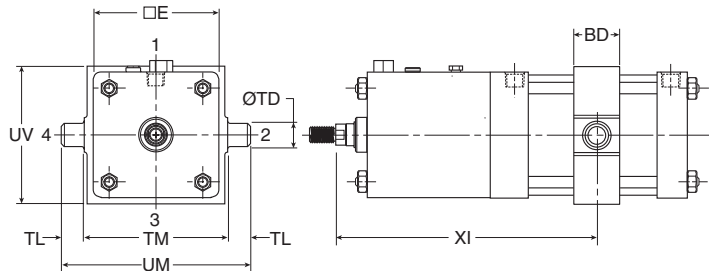
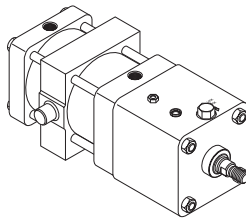

**Note:** Style DD requires minimum stroke per table.

**Style DD Dimensions**

Bore Size	Rod No.	Rod Dia. MM	E	BD	TD		TL	TM	UM	UV	Min. XI	Min. Stroke
					+0.000	-0.001						
6	1	1-3/8	6.500	2.500	1.375	1.375	1.375	7.625	10.375	7.000	11.16	6.125
	3	1-3/4	6.500	2.500	1.375	1.375	1.375	7.625	10.375	7.000	11.91	6.125
8	1	1-3/8	8.500	2.500	1.375	1.375	1.375	9.750	12.500	9.500	11.31	6.500
	3	1-3/4	8.500	2.500	1.375	1.375	1.375	9.750	12.500	9.500	12.06	6.500

**Kits & Accessories**

See page B34 to B36.



For inventory, lead times, and kit lookup, visit [www.pdnplu.com](http://www.pdnplu.com)

**B**

Tie Rod Pneumatic  
Cylinders

4MA  
Series

4MAJ  
Series

ACYB  
Option

LPSO  
Option

P1D  
Series

P1F  
Series

2MNR  
Series



For inventory, lead times, and kit  
lookup, visit [www.pdnplu.com](http://www.pdnplu.com)

B61

**Parker Hannifin Corporation**  
Pneumatic Division  
Wadsworth, Ohio  
[www.parker.com/pneumatics](http://www.parker.com/pneumatics)

How To Order ACVB Option

How to Order ACVB Option fully assembled to 4MA Cylinder

- B**
- Tie Rod Pneumatic Cylinders
- 4MA Series
- 4MAJ Series
- ACVB Option
- LP50 Option
- P1D Series
- P1F Series
- 2MNR Series

<b>2.00</b>		<b>J</b>		<b>4MA</b>		<b>U</b>		<b>S</b>	<b>1</b>	<b>4</b>		<b>A</b>		<b>6.000</b>																																																																																																																																																											
<table border="1" style="width: 100%; border-collapse: collapse;"> <tr><th colspan="2">Bore Size</th></tr> <tr><td>1.50</td></tr> <tr><td>2.00</td></tr> <tr><td>2.50</td></tr> <tr><td>3.25</td></tr> <tr><td>4.00</td></tr> <tr><td>5.00</td></tr> </table>	Bore Size		1.50	2.00	2.50	3.25	4.00	5.00	<table border="1" style="width: 100%; border-collapse: collapse;"> <tr><th colspan="2">Double Rod Cylinder</th></tr> <tr><td colspan="2">Specify "K" only if double rod cylinder is required.</td></tr> </table>	Double Rod Cylinder		Specify "K" only if double rod cylinder is required.		<table border="1" style="width: 100%; border-collapse: collapse;"> <tr><th colspan="2">Series</th></tr> <tr><td colspan="2">4MA</td></tr> </table>	Series		4MA		<table border="1" style="width: 100%; border-collapse: collapse;"> <tr><th colspan="2">Ports</th></tr> <tr><td>U</td><td>NPTF</td></tr> </table>	Ports		U	NPTF	<table border="1" style="width: 100%; border-collapse: collapse;"> <tr><th colspan="2">Piston Rod Number</th></tr> <tr><td colspan="2">See 4MA section for more details.</td></tr> </table>	Piston Rod Number		See 4MA section for more details.		<table border="1" style="width: 100%; border-collapse: collapse;"> <tr><th colspan="2">Stroke Length**</th></tr> <tr><td colspan="2">Specify stroke length required in inches.</td></tr> </table>	Stroke Length**		Specify stroke length required in inches.		<table border="1" style="width: 100%; border-collapse: collapse;"> <tr><th colspan="2">Seals</th></tr> <tr><td>Blank</td><td>Standard (nitrile seals)</td></tr> <tr><td>E</td><td>Fluorocarbon Rod Wiper And Rod Seal Only</td></tr> <tr><td>M</td><td>Metallic Rod Wiper, Nitrile Seals</td></tr> </table>	Seals		Blank	Standard (nitrile seals)	E	Fluorocarbon Rod Wiper And Rod Seal Only	M	Metallic Rod Wiper, Nitrile Seals	<table border="1" style="width: 100%; border-collapse: collapse;"> <tr><th colspan="2">Cushion Cap End</th></tr> <tr><td>Blank</td><td>Non-Cushioned Cap End</td></tr> <tr><td>C</td><td>Cushioned Cap End</td></tr> </table>	Cushion Cap End		Blank	Non-Cushioned Cap End	C	Cushioned Cap End	<table border="1" style="width: 100%; border-collapse: collapse;"> <tr><th colspan="2">Cushion Head End</th></tr> <tr><td>Blank</td><td>Non-Cushioned Head End</td></tr> <tr><td>C</td><td>Cushioned Head End</td></tr> </table>	Cushion Head End		Blank	Non-Cushioned Head End	C	Cushioned Head End	<table border="1" style="width: 100%; border-collapse: collapse;"> <tr><th colspan="2">Special Modification</th></tr> <tr><td colspan="2">Specify "S" for ACVB options and any other special modification other than rod end. See examples below.</td></tr> </table>	Special Modification		Specify "S" for ACVB options and any other special modification other than rod end. See examples below.		<table border="1" style="width: 100%; border-collapse: collapse;"> <tr><th colspan="2">Piston Rod Thread Type</th></tr> <tr><td>A</td><td>Standard (UNF Unified Thread)</td></tr> <tr><td>W</td><td>BSF British Fine</td></tr> <tr><td>M</td><td>Metric (see page B78)</td></tr> </table>	Piston Rod Thread Type		A	Standard (UNF Unified Thread)	W	BSF British Fine	M	Metric (see page B78)	<table border="1" style="width: 100%; border-collapse: collapse;"> <tr><th colspan="2">Rod Material and Gland Code</th></tr> <tr><td>Blank</td><td>Standard Rod and Gland</td></tr> <tr><td>H</td><td>Standard Rod and HI LOAD Gland</td></tr> <tr><td>Y</td><td>17-4 PH stainless Steel Rod And Standard Gland</td></tr> <tr><td>Z</td><td>17-4 PH Stainless Steel Rod And Hi Load Gland</td></tr> <tr><td>J</td><td>303 Stainless Steel Rod And Standard Gland</td></tr> <tr><td>K</td><td>303 Stainless Steel Rod And Hi Load Gland</td></tr> <tr><td>S</td><td>316 Stainless Steel Rod And Standard Gland</td></tr> <tr><td>T</td><td>316 Stainless Steel Rod And Hi Load Gland</td></tr> </table>	Rod Material and Gland Code		Blank	Standard Rod and Gland	H	Standard Rod and HI LOAD Gland	Y	17-4 PH stainless Steel Rod And Standard Gland	Z	17-4 PH Stainless Steel Rod And Hi Load Gland	J	303 Stainless Steel Rod And Standard Gland	K	303 Stainless Steel Rod And Hi Load Gland	S	316 Stainless Steel Rod And Standard Gland	T	316 Stainless Steel Rod And Hi Load Gland	<table border="1" style="width: 100%; border-collapse: collapse;"> <tr><th colspan="2">Piston Rod Thread Style</th></tr> <tr><td>4</td><td>Small Male</td></tr> <tr><td>8</td><td>Intermediate Male</td></tr> <tr><td>9</td><td>Short Female</td></tr> <tr><td>55</td><td>For Use With Split Coupler</td></tr> <tr><td>3</td><td>Special (And Specify All Dimensions Required)</td></tr> <tr><td>6</td><td>Full Male</td></tr> </table>	Piston Rod Thread Style		4	Small Male	8	Intermediate Male	9	Short Female	55	For Use With Split Coupler	3	Special (And Specify All Dimensions Required)	6	Full Male	<table border="1" style="width: 100%; border-collapse: collapse;"> <tr><th colspan="2">ACVB Minimum Stroke Requirements**</th></tr> <tr><th>Bore</th><th>4MA</th></tr> <tr><th colspan="2">Compact Manifold</th></tr> <tr><td>1.50</td><td>0.500</td></tr> <tr><td>2.00</td><td>0.500</td></tr> <tr><td>2.50</td><td>0.438</td></tr> <tr><th colspan="2">Full Manifold</th></tr> <tr><td>1.50</td><td>5.813</td></tr> <tr><td>2.00</td><td>5.813</td></tr> <tr><td>2.50</td><td>5.750</td></tr> <tr><td>3.25</td><td>5.500</td></tr> <tr><td>4.00</td><td>5.500</td></tr> <tr><td>5.00</td><td>5.250</td></tr> </table>	ACVB Minimum Stroke Requirements**		Bore	4MA	Compact Manifold		1.50	0.500	2.00	0.500	2.50	0.438	Full Manifold		1.50	5.813	2.00	5.813	2.50	5.750	3.25	5.500	4.00	5.500	5.00	5.250	<table border="1" style="width: 100%; border-collapse: collapse;"> <tr><th colspan="2">Piston Type</th></tr> <tr><td>Blank</td><td>Lipseals and Magnetic Ring (legacy) (standard for 4ML)</td></tr> <tr><td>1</td><td>Lipseals, No Magnetic Ring (legacy)</td></tr> <tr><td>2</td><td>Lipseals, No Magnetic Ring (aluminum piston)</td></tr> <tr><td>3</td><td>Lipseals and Magnetic Ring (aluminum piston)</td></tr> <tr><td>4</td><td>Bumper Seals, No Magnetic Ring</td></tr> <tr><td>6</td><td>Bumper Seals and Magnetic Ring</td></tr> <tr><td>B</td><td>Lipseals, 1/4" Thick Bumpers Both Ends</td></tr> <tr><td>H</td><td>Lipseals, 1/4" Thick Bumper Head End</td></tr> <tr><td>C</td><td>Lipseals, 1/4" Thick Bumper Cap End</td></tr> <tr><td>D</td><td>Lipseals and Magnetic Ring, 1/4" Thick Bumpers Both Ends</td></tr> <tr><td>F</td><td>Lipseals and Magnetic Ring, 1/4" Thick Bumper Head End</td></tr> <tr><td>R</td><td>Lipseals and Magnetic Ring, 1/4" thick Bumper Cap End</td></tr> </table>	Piston Type		Blank	Lipseals and Magnetic Ring (legacy) (standard for 4ML)	1	Lipseals, No Magnetic Ring (legacy)	2	Lipseals, No Magnetic Ring (aluminum piston)	3	Lipseals and Magnetic Ring (aluminum piston)	4	Bumper Seals, No Magnetic Ring	6	Bumper Seals and Magnetic Ring	B	Lipseals, 1/4" Thick Bumpers Both Ends	H	Lipseals, 1/4" Thick Bumper Head End	C	Lipseals, 1/4" Thick Bumper Cap End	D	Lipseals and Magnetic Ring, 1/4" Thick Bumpers Both Ends	F	Lipseals and Magnetic Ring, 1/4" Thick Bumper Head End	R	Lipseals and Magnetic Ring, 1/4" thick Bumper Cap End	<p><b>Cylinder Construction</b></p> <table border="1" style="width: 100%; border-collapse: collapse;"> <tr><td>Blank</td><td>Standard (extruded body, standard round lobe orientation) *</td></tr> <tr><td>A</td><td>Extruded Body, Round Lobe Orientation Rotated 90 Degrees From Standard *</td></tr> <tr><td>N</td><td>Extruded Body, Round Lobe Orientation Rotated 180 Degrees From Standard *</td></tr> <tr><td>Z</td><td>Extruded Body, Round Lobe Orientation Rotated 270 Degrees From Standard *</td></tr> <tr><td>T</td><td>Aluminum Round Tube And Carbon Steel Tie</td></tr> </table>	Blank	Standard (extruded body, standard round lobe orientation) *	A	Extruded Body, Round Lobe Orientation Rotated 90 Degrees From Standard *	N	Extruded Body, Round Lobe Orientation Rotated 180 Degrees From Standard *	Z	Extruded Body, Round Lobe Orientation Rotated 270 Degrees From Standard *	T	Aluminum Round Tube And Carbon Steel Tie
Bore Size																																																																																																																																																																									
1.50																																																																																																																																																																									
2.00																																																																																																																																																																									
2.50																																																																																																																																																																									
3.25																																																																																																																																																																									
4.00																																																																																																																																																																									
5.00																																																																																																																																																																									
Double Rod Cylinder																																																																																																																																																																									
Specify "K" only if double rod cylinder is required.																																																																																																																																																																									
Series																																																																																																																																																																									
4MA																																																																																																																																																																									
Ports																																																																																																																																																																									
U	NPTF																																																																																																																																																																								
Piston Rod Number																																																																																																																																																																									
See 4MA section for more details.																																																																																																																																																																									
Stroke Length**																																																																																																																																																																									
Specify stroke length required in inches.																																																																																																																																																																									
Seals																																																																																																																																																																									
Blank	Standard (nitrile seals)																																																																																																																																																																								
E	Fluorocarbon Rod Wiper And Rod Seal Only																																																																																																																																																																								
M	Metallic Rod Wiper, Nitrile Seals																																																																																																																																																																								
Cushion Cap End																																																																																																																																																																									
Blank	Non-Cushioned Cap End																																																																																																																																																																								
C	Cushioned Cap End																																																																																																																																																																								
Cushion Head End																																																																																																																																																																									
Blank	Non-Cushioned Head End																																																																																																																																																																								
C	Cushioned Head End																																																																																																																																																																								
Special Modification																																																																																																																																																																									
Specify "S" for ACVB options and any other special modification other than rod end. See examples below.																																																																																																																																																																									
Piston Rod Thread Type																																																																																																																																																																									
A	Standard (UNF Unified Thread)																																																																																																																																																																								
W	BSF British Fine																																																																																																																																																																								
M	Metric (see page B78)																																																																																																																																																																								
Rod Material and Gland Code																																																																																																																																																																									
Blank	Standard Rod and Gland																																																																																																																																																																								
H	Standard Rod and HI LOAD Gland																																																																																																																																																																								
Y	17-4 PH stainless Steel Rod And Standard Gland																																																																																																																																																																								
Z	17-4 PH Stainless Steel Rod And Hi Load Gland																																																																																																																																																																								
J	303 Stainless Steel Rod And Standard Gland																																																																																																																																																																								
K	303 Stainless Steel Rod And Hi Load Gland																																																																																																																																																																								
S	316 Stainless Steel Rod And Standard Gland																																																																																																																																																																								
T	316 Stainless Steel Rod And Hi Load Gland																																																																																																																																																																								
Piston Rod Thread Style																																																																																																																																																																									
4	Small Male																																																																																																																																																																								
8	Intermediate Male																																																																																																																																																																								
9	Short Female																																																																																																																																																																								
55	For Use With Split Coupler																																																																																																																																																																								
3	Special (And Specify All Dimensions Required)																																																																																																																																																																								
6	Full Male																																																																																																																																																																								
ACVB Minimum Stroke Requirements**																																																																																																																																																																									
Bore	4MA																																																																																																																																																																								
Compact Manifold																																																																																																																																																																									
1.50	0.500																																																																																																																																																																								
2.00	0.500																																																																																																																																																																								
2.50	0.438																																																																																																																																																																								
Full Manifold																																																																																																																																																																									
1.50	5.813																																																																																																																																																																								
2.00	5.813																																																																																																																																																																								
2.50	5.750																																																																																																																																																																								
3.25	5.500																																																																																																																																																																								
4.00	5.500																																																																																																																																																																								
5.00	5.250																																																																																																																																																																								
Piston Type																																																																																																																																																																									
Blank	Lipseals and Magnetic Ring (legacy) (standard for 4ML)																																																																																																																																																																								
1	Lipseals, No Magnetic Ring (legacy)																																																																																																																																																																								
2	Lipseals, No Magnetic Ring (aluminum piston)																																																																																																																																																																								
3	Lipseals and Magnetic Ring (aluminum piston)																																																																																																																																																																								
4	Bumper Seals, No Magnetic Ring																																																																																																																																																																								
6	Bumper Seals and Magnetic Ring																																																																																																																																																																								
B	Lipseals, 1/4" Thick Bumpers Both Ends																																																																																																																																																																								
H	Lipseals, 1/4" Thick Bumper Head End																																																																																																																																																																								
C	Lipseals, 1/4" Thick Bumper Cap End																																																																																																																																																																								
D	Lipseals and Magnetic Ring, 1/4" Thick Bumpers Both Ends																																																																																																																																																																								
F	Lipseals and Magnetic Ring, 1/4" Thick Bumper Head End																																																																																																																																																																								
R	Lipseals and Magnetic Ring, 1/4" thick Bumper Cap End																																																																																																																																																																								
Blank	Standard (extruded body, standard round lobe orientation) *																																																																																																																																																																								
A	Extruded Body, Round Lobe Orientation Rotated 90 Degrees From Standard *																																																																																																																																																																								
N	Extruded Body, Round Lobe Orientation Rotated 180 Degrees From Standard *																																																																																																																																																																								
Z	Extruded Body, Round Lobe Orientation Rotated 270 Degrees From Standard *																																																																																																																																																																								
T	Aluminum Round Tube And Carbon Steel Tie																																																																																																																																																																								
<p>* See Table on page B5.</p>																																																																																																																																																																									
<p><b>Example</b> 2.00 CJ4MAUS14AC 6.000 S = ACVB Valve Combination S = 3C2B54 Manifold Code (See following page.)</p> <p><b>Flow Control Option</b> Add "S = with SP37 Flow Controls" to item notes</p> <p><b>Muffler Option</b> Add "S = with EM Mufflers" to item notes</p>																																																																																																																																																																									
<p>** For desired strokes less than the minimum requirement, specify a stop tube for the cylinder assembly. Total stroke should be (desired net stroke) + (stop tube length to help exceed minimum stroke). Stop tube only available for 4MA with aluminum piston.</p> <p>Example: 1.50" bore 4MA with 5.000" of desired net stroke: Gross stroke = 5.813" Stop tube = 0.813" Net stroke = 5.000"</p> <p><b>Note:</b> place gross stroke in cylinder model number and specify stop tube length and net stroke in the item notes.</p>																																																																																																																																																																									



For inventory, lead times, and kit lookup, visit [www.pdnplu.com](http://www.pdnplu.com)

How To Order ACVB Option

ACVB Series Valve/Manifold Codes

Valve Series	
3	B3
5	B5
6	B6

Pilot Source / Pilot Exhaust	
A	Internal - Port #1 / Tapped M5 (B5, B6 only)
B	Internal - Port #1 / Vented
0	None. Remote Pilot Valve

Voltage	
4	24 VDC
5	110 VAC
X	Remote Pilot

Manifold Type / Location	
C	Compact Manifold / Cap End (For use with B3 valve only)
D	Compact Manifold / Head End (For use with B3 valve only)
F	Full Manifold / Cap End (For use with B3, B5 or B6 valves) **
G	Full Manifold / Head End (For use with B3, B5 or B6 valves)

Operator Type / Function	
1	Single Solenoid / Air Return
2	Double Solenoid
3	Single Remote Pilot / Air Return
4	Double Remote Pilot

Connector / Valve Series Available	
0	None / B3, B5, B6 (Remote Pilot)
5	15mm 3-PIN DIN 43650C / B3, B5, B6 (Male Connector)
6	15mm 3-PIN DIN 43650C (rotated 180°) / B3, B5, B6 (Male Connector)
A	30mm Square 3-PIN ISO 4400 Form A / B5, B6 (Male Connector)
B	22mm Rectangular 3-PIN Type B Industrial / B5, B6 (Male Connector)
C	3-PIN Automotive Mini / B5 (Female Connector)
D	5-PIN Automotive Mini / B5 (Female Connector)
F	Hazardous Duty 1/2" Conduit 18" Leads / B5, B6
H	1/2" NPT Conduit 18" Leads / B5, B6

**NOTE:** Cylinders with single solenoid valves mounted at the CAP END will be NORMALLY RETRACTED. Cylinders with single solenoid valves mounted at the HEAD END will be NORMALLY EXTENDED.

Customer orientation of connector at 45 degree increments possible on Options A through H on B5 and B6 valves.

Example: 6 F 2 A 5 5

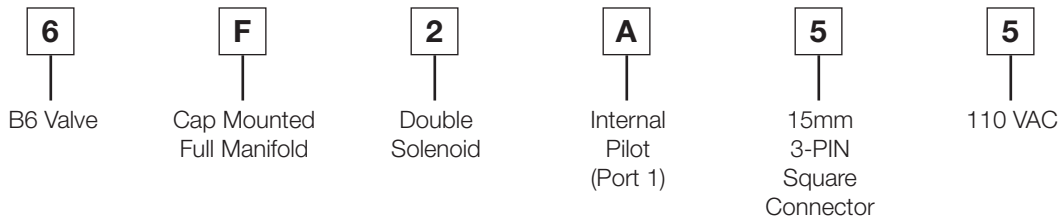

B	Tie Rod Pneumatic Cylinders
4MA Series	4MAJ Series
ACVB Option	LPSO Option
P1D Series	P1F Series
2MNR Series	



For inventory, lead times, and kit lookup, visit [www.pdnplu.com](http://www.pdnplu.com)

**Compact Manifold**



- Standard Fluid – Dry, filtered air.
- Standard Temperature: -5°F to 120°F (-15°C to 49°C).
- Maximum 145 PSI operating pressure.
- Fits 1-1/2" through 2-1/2" Bore 4MA standard cylinders.
- Uses standard Parker fittings, tubing, and seals.
- Compact manifold accommodates B3 Series valve from Parker Pneumatic Division North America without field modification to cylinder.

**Full Manifold**



- Standard Fluid: Dry, filtered air.
- Standard Temperature: -5° F to 120° F (-15°C to 49°C).
- Maximum 145 PSI operating pressure.
- Fits 1-1/2" through 5" Bore 4MA standard cylinders.
- Uses standard Parker fittings, tubing, and seals.
- Full manifold accommodates B3, B5 and B6 series Parker Pneumatic valves, without field modification to cylinder (B6 series shown).
- Bolt pattern conforms to NAMUR standard on B5 and B6 valves.
- Manifold and valve do not overhang beyond head or cap fasteners.

<b>B</b>
Tie Rod Pneumatic Cylinders
4MA Series
4MAJ Series
ACVB Option
LPS0 Option
P1D Series
P1F Series
2MNR Series



For inventory, lead times, and kit lookup, visit [www.pdnplu.com](http://www.pdnplu.com)

B64



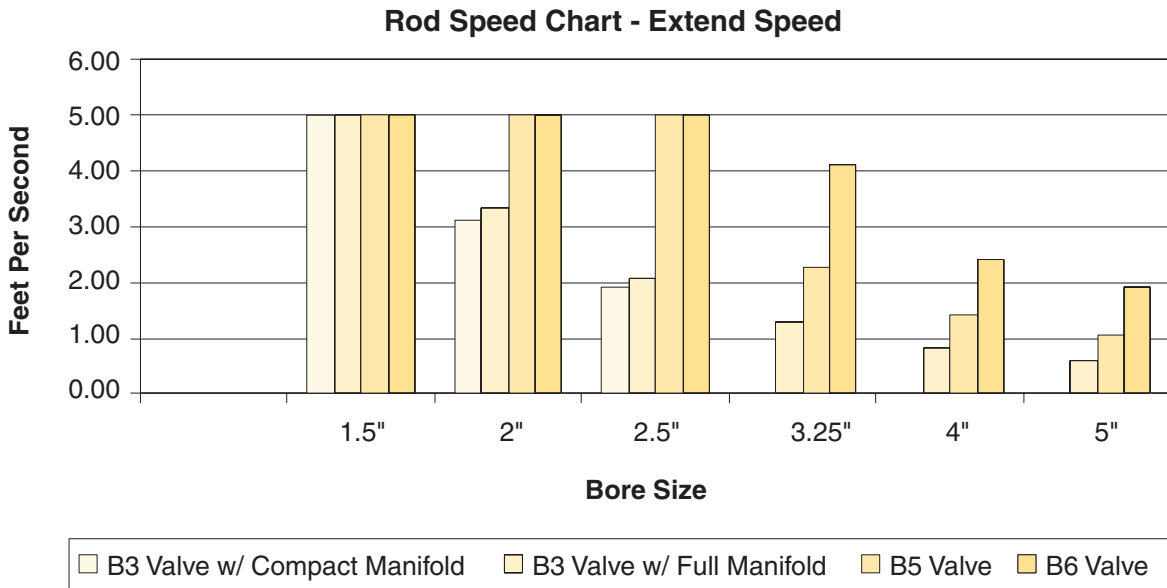

**Steps to size a cylinder-valve system**

**Step 1. Gather the Application Parameters**

- Total load
- Maximum velocity needed to move load in specified time\*
- Minimum pressure available

**Step 2. Size Cylinder**

Use equations in engineering section of Pneumatic Actuator Catalog to calculate minimum bore size

**Step 3. Size Valve/Manifold**

- Use the Rod Speed Chart above
- Choose valve/manifold system that will supply maximum velocity needed for bore size chosen above

**Step 4. Choose the Appropriate Model Code\*\***

- Specify necessary valve and manifold
- Choose type of control required
- Choose type of connection and voltage required

\* If maximum velocity is not easily calculated, divide the total stroke distance by the total stroke time and multiply by 2.

\*\* See the ACVB Series Valve/Manifold Code page for more details.

B
Tie Rod Pneumatic Cylinders
4MA Series
4MAJ Series
ACVB Option
LPSO Option
P1D Series
P1F Series
2MNR Series



For inventory, lead times, and kit lookup, visit [www.pdnplu.com](http://www.pdnplu.com)

**Compact Manifold**

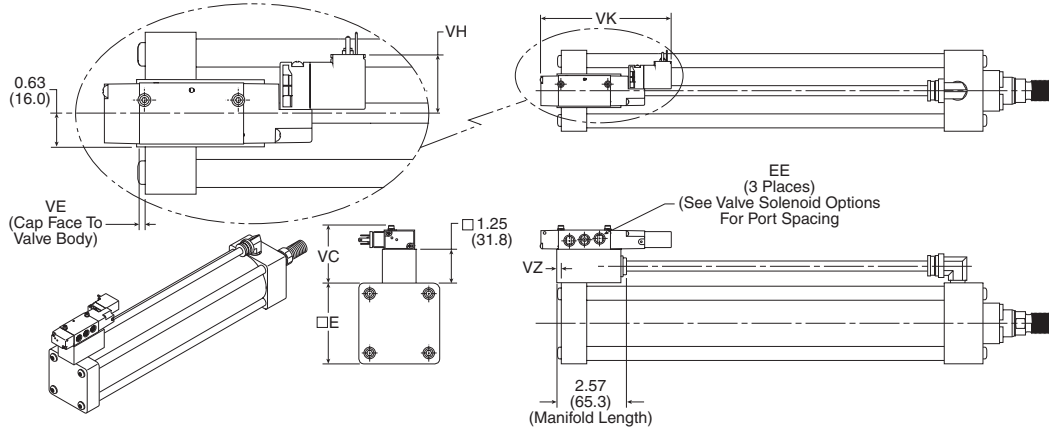

**Full Manifold**

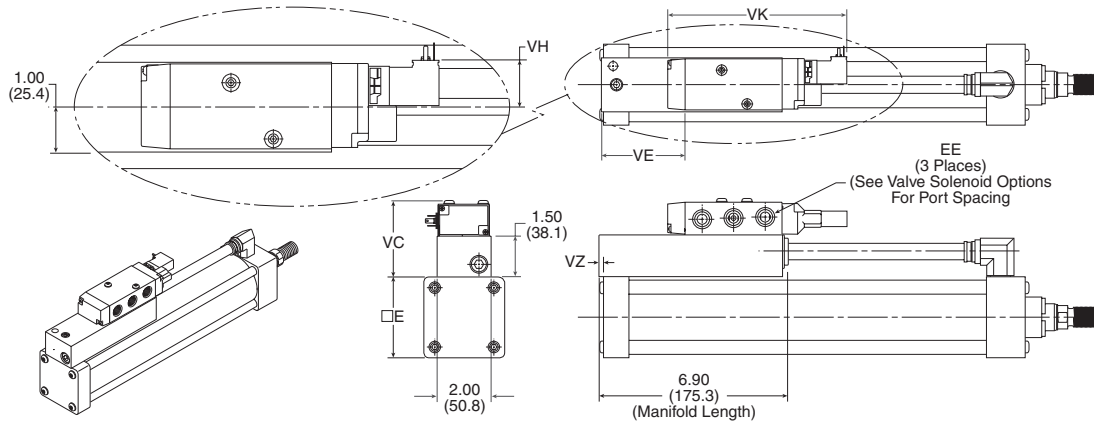

**Dimensions**

Bore	E (SQ.)	Manifold	Valve	VE*	VZ**	
1-1/2	2	Compact	B3	0.17 (4.3)	0.23 (5.8)	
			B3	3.78 (96.3)	0.23 (5.8)	
			B5	3.48 (88.4)	0.13 (3.3)	
		Full	B6	2.97 (75.4)	0.13 (3.3)	
			Compact	B3	0.17 (4.3)	0.23 (5.8)
				B3	3.78 (96.3)	0.13 (3.3)
B6	2.97 (75.4)	0.13 (3.3)				
2	2-1/2	Full	B5	3.36 (85.3)	0.13 (3.3)	
			B6	2.97 (75.4)	0.13 (3.3)	
			B3	3.90 (99.1)	0.00	
		Full	B5	3.48 (88.4)	0.00	
			B6	3.10 (78.7)	0.00	
			B3	3.90 (99.1)	0.00	
3-1/4	3-3/4	Full	B5	3.48 (88.4)	0.00	
			B6	3.10 (78.7)	0.00	
			B3	3.90 (99.1)	0.00	
		Full	B5	3.48 (88.4)	0.00	
			B6	3.10 (78.7)	0.00	
			B3	3.90 (99.1)	0.00	
4	4-1/2	Full	B5	3.48 (88.4)	0.00	
			B6	3.10 (78.7)	0.00	
			B3	3.90 (99.1)	0.00	
5	5-1/2	Full	B5	3.48 (88.4)	0.00	
			B6	3.10 (78.7)	0.00	
			B3	3.90 (99.1)	0.00	

Valve	EE (NPTF)	VH	VK	VC	
B3	1/8	1.09 (27.7)	4.67 (118.6)	Compact Manifold	2.12 (53.8)
				Full Manifold	2.37 (60.2)
B5	1/4	1.12 (28.4)	5.78 (146.8)	Full Manifold	2.81 (71.4)
B6	3/8	1.12 (28.4)	6.67 (169.4)	Full Manifold	2.81 (71.4)

\* VE = Dimension from edge of endcap to edge of valve body.

\*\* VZ = Dimension from edge of endcap to edge of manifold.

**Note:** Dimensions shown are for a single solenoid enclosure with Option 5. For other valve or enclosure option dimensions, see pages B68-B69.

**B** Tie Rod Pneumatic Cylinders

4MA Series

4MAJ Series

ACVB Option

LPSO Option

P1D Series

P1F Series

2MNR Series



For inventory, lead times, and kit lookup, visit [www.pdnplu.com](http://www.pdnplu.com)

**Compact Manifold**

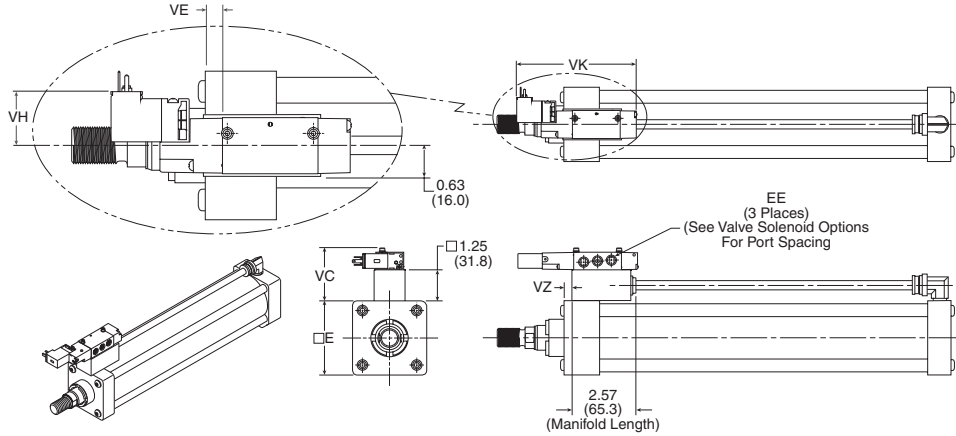

**Full Manifold**

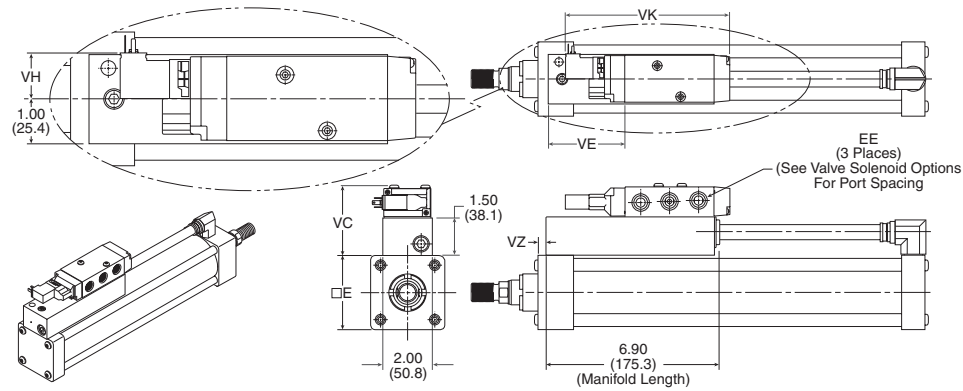

**Dimensions**

Bore	E (SQ.)	Manifold	Valve	VE*	VZ**
1-1/2	2	Compact	B3	0.26 (6.6)	0.20 (5.1)
			B3	4.21 (106.9)	0.31 (7.9)
			B5	3.79 (96.3)	0.31 (7.9)
		Full	B6	3.41 (86.6)	0.31 (7.9)
			B3	0.26 (6.6)	0.20 (5.1)
			B3	4.21 (106.9)	0.31 (7.9)
2	2-1/2	Compact	B5	3.79 (96.3)	0.31 (7.9)
			B6	3.41 (86.6)	0.31 (7.9)
			B3	0.33 (8.4)	0.27 (6.9)
		Full	B3	4.27 (108.5)	0.38 (9.6)
			B5	3.86 (98.0)	0.38 (9.6)
			B6	3.47 (88.1)	0.38 (9.6)
3-1/4	3-3/4	Compact	B3	4.40 (111.8)	0.50 (12.7)
			B5	3.98 (101.1)	0.50 (12.7)
			B6	3.60 (91.4)	0.50 (12.7)
		Full	B3	4.40 (111.8)	0.50 (12.7)
			B5	3.98 (101.1)	0.50 (12.7)
			B6	3.60 (91.4)	0.50 (12.7)
4	4-1/2	Compact	B3	4.40 (111.8)	0.50 (12.7)
			B5	3.98 (101.1)	0.50 (12.7)
			B6	3.60 (91.4)	0.50 (12.7)
		Full	B3	4.40 (111.8)	0.50 (12.7)
			B5	3.98 (101.1)	0.50 (12.7)
			B6	3.60 (91.4)	0.50 (12.7)
5	5-1/2	Compact	B3	4.40 (111.8)	0.50 (12.7)
			B5	3.98 (101.1)	0.50 (12.7)
			B6	3.60 (91.4)	0.50 (12.7)
		Full	B3	4.40 (111.8)	0.50 (12.7)
			B5	3.98 (101.1)	0.50 (12.7)
			B6	3.60 (91.4)	0.50 (12.7)

Valve	EE		VK	VC	
	(NPTF)	VH			
B3	1/8	1.09 (27.7)	4.67 (118.6)	Compact Manifold	2.12 (53.8)
				Full Manifold	2.37 (60.2)
B5	1/4	1.12 (28.4)	5.78 (146.8)	Compact Manifold	2.81 (71.4)
				Full Manifold	2.81 (71.4)
B6	3/8	1.12 (28.4)	6.67 (169.4)	Full Manifold	2.81 (71.4)

\* VE = Dimension from edge of endcap to edge of valve body.

\*\* VZ = Dimension from edge of endcap to edge of manifold.

**Note:** single solenoid enclosure 5 shown. For other valve or options, see pages B68-B69.



For inventory, lead times, and kit lookup, visit [www.pdnplu.com](http://www.pdnplu.com)

B3 Valve

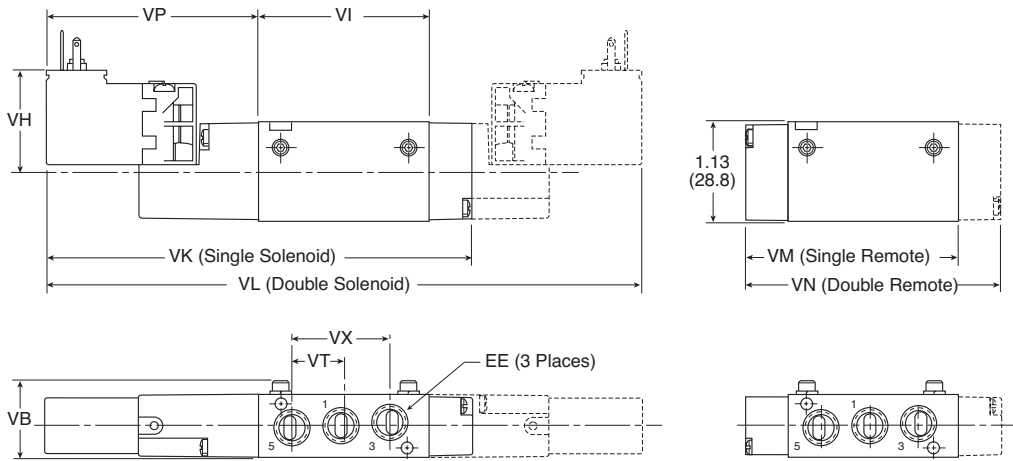

B5 and B6 Valve

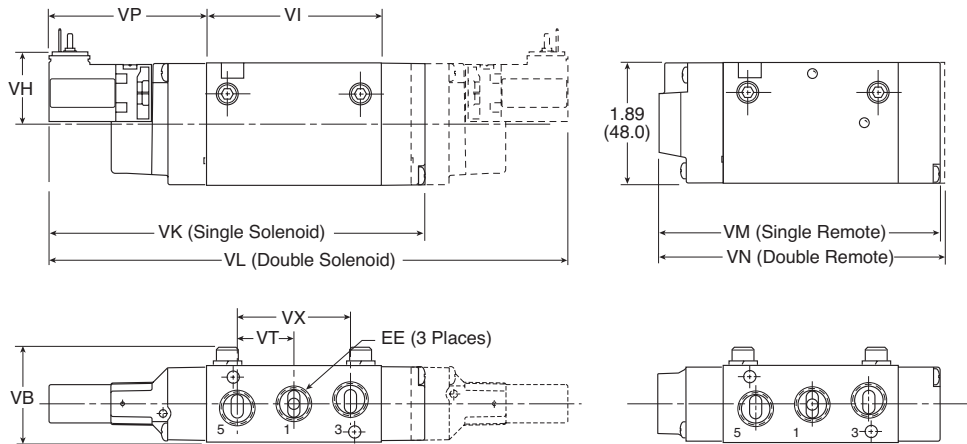

Valve Dimensions

Valve	EE (NPTF)	VB	VH	VI	VK	VL	VM	VN	VP	VT	VX
B3	1/8	0.87 (22.1)	1.09 (27.7)	1.93 (49.0)	4.67 (118.6)	6.44 (163.6)	3.12 (79.2)	3.33 (84.6)	2.25 (57.2)	0.56 (14.2)	1.12 (28.4)
B5	1/4	1.31 (33.3)	1.12 (28.4)	2.70 (68.6)	5.78 (146.8)	7.51 (190.8)	4.37 (111.0)	4.70 (119.4)	2.40 (61.0)	0.88 (22.4)	1.75 (44.5)
B6	3/8	1.31 (33.3)	1.12 (28.4)	3.60 (91.5)	6.67 (169.4)	8.41 (213.6)	5.26 (133.6)	5.59 (142.0)	2.40 (61.0)	1.17 (29.7)	2.34 (59.4)

**B**  
 Tie Rod Pneumatic Cylinders  
 4MA Series  
 4MAJ Series  
 ACVB Option  
 LPSO Option  
 P1D Series  
 P1F Series  
 2MNR Series



For inventory, lead times, and kit lookup, visit [www.pdnplu.com](http://www.pdnplu.com)

Optional Electrical Connections

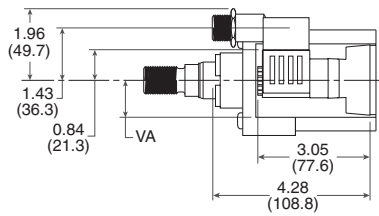

Enclosure C, D

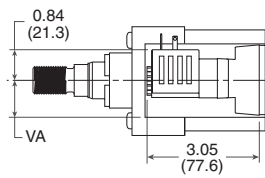

Enclosure A

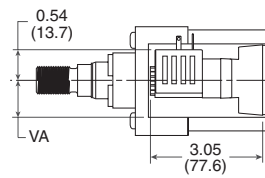

Solenoid Option A, B, C, D, F & H  
(Can be rotated in 45° increments as shown)

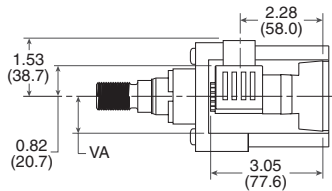

Enclosure 5

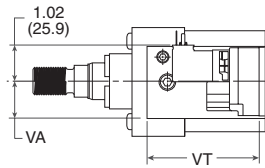

Enclosure F & H  
(B5 & B6 Only)

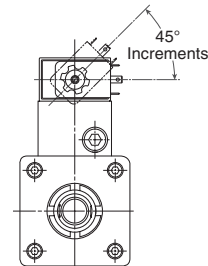

Enclosure B

Optional Electrical Connections Dimensions

Valve	VA	VT
B3	0.63 (16.0)	2.25 (57.2)
B5	1.00 (25.4)	2.40 (61.0)
B6	1.00 (25.4)	2.40 (61.0)

B

Tie Rod Pneumatic Cylinders

4MA Series

4MAJ Series

ACVB Option

LPSO Option

P1D Series

P1F Series

2MNR Series



For inventory, lead times, and kit lookup, visit [www.pdnplu.com](http://www.pdnplu.com)

**Female Electrical Connectors**

**15mm 3-Pin DIN 43650C**

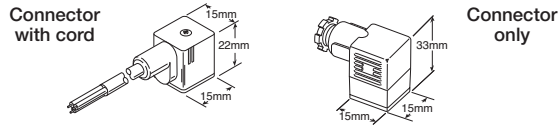

	Cord Length	Connector	Connector with Cord
Unlighted	6 Feet	<b>PS2932BP</b>	<b>PS2932JBP</b>
Light – 24VAC or DC	6 Feet	<b>PS294679BP</b>	<b>PS2946J79BP*</b>
Light – 110/120VAC	6 Feet	<b>PS294683BP</b>	<b>PS2946J83BP*</b>

\* LED with surge suppression.

**Note:** Max ø6.5mm cable size required for connector w/o 6' (2m) cord. IP65 rated when properly installed.

**Engineering data:**

Conductors: 2 poles plus ground  
Cable range (connector only): 4 to 6mm (0.16 to 0.24 Inch)  
Contact spacing: 8mm

**22mm Rectangular 3-Pin – Type B Industrial  
(Use with Enclosure “B”)**

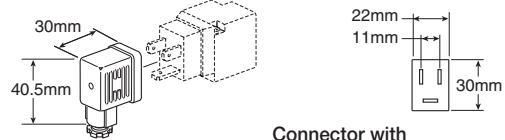

Description	Connector with 6' (2m) Cord	Connector
Unlighted	<b>PS2429JBP</b>	<b>PS2429BP</b>
Light – 24V60Hz, 24VDC	<b>PS2430J79BP*</b>	<b>PS243079BP</b>
Light – 120V/60Hz	<b>PS2430J83BP*</b>	<b>PS243083BP</b>

\* LED with surge suppression.

**Note:** Max ø6.5mm cable size required for connector w/o 6' (2m) cord. IP65 rated when properly installed.

**Engineering data:**

Conductors: 2 poles plus ground  
Cable range (connector only): 6 to 8mm (0.24 to 0.31 Inch)  
Contact spacing: 11mm

**30mm Square 3-Pin – ISO 4400, DIN 43650A  
(Use with Enclosure “A”)**

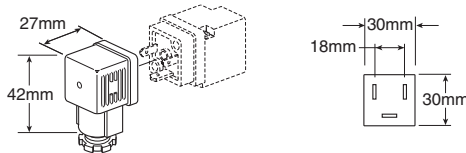

Description	Connector with 6' (2m) Cord	Connector
Unlighted	<b>PS2028JCP</b>	<b>PS2028BP</b>
Light – 6-48V, 50/60Hz, 6-48VDC	<b>PS2032J79CP*</b>	<b>PS203279BP</b>
Light – 120V/60Hz	<b>PS2032J83CP*</b>	<b>PS203283BP</b>

\* LED with surge suppression.

**Note:** Max ø6.5mm cable size required for connector w/o 6' (2m) cord. IP65 rated when properly installed.

**Engineering data:**

Conductors: 2 poles plus ground  
Cable range (connector only): 8 to 10mm (0.31 to 0.39 Inch)  
Contact spacing: 8mm

**3-Pin / 5-Pin Male Automotive Connectors  
(Use on 22mm Rectangular 3-Pin Solenoid)**

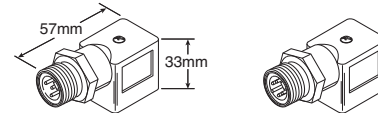

Description	3-pin	5-pin
Unlighted	<b>PS2893CP</b>	<b>PS2893DP</b>
Lighted - Voltage	<b>PS2893C##P</b>	<b>PS2893D83P</b>

## – 79 = 24VDC & 24VAC  
83 = 120VAC

**B**  
Tie Rod Pneumatic Cylinders  
4MA Series  
4MAJ Series  
ACVB Option  
LPSO Option  
P1D Series  
P1F Series  
2MNR Series



For inventory, lead times, and kit lookup, visit [www.pdnplu.com](http://www.pdnplu.com)

**Linear Position Sensor for Continuous Position Feedback**

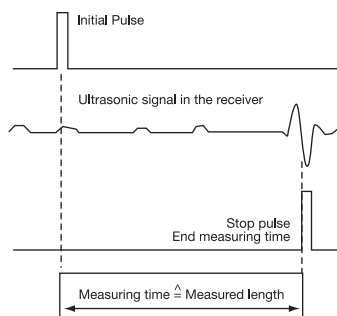

Generation of the ultrasonic torsion pulse in a metallic conductor based on the principle of magnetostriction.

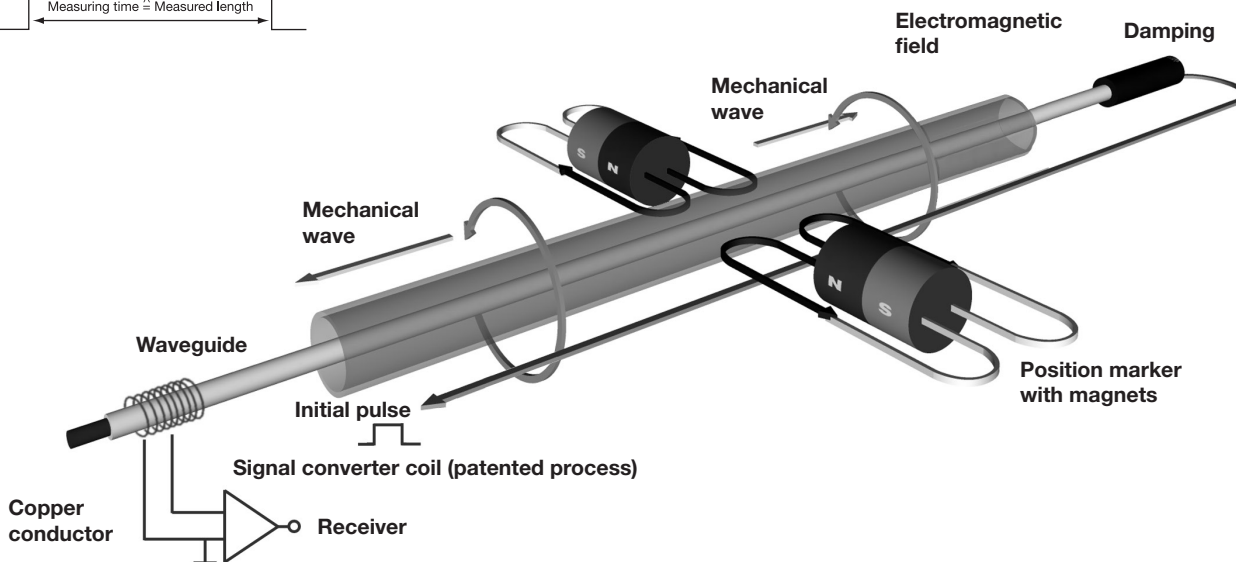
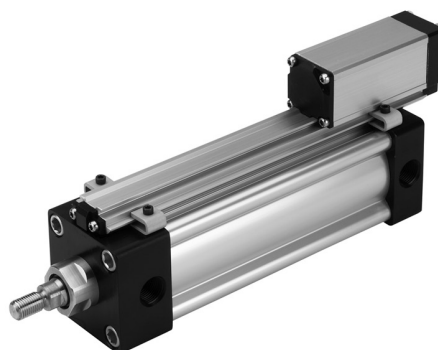

**Principles of Operation**

The measuring element (“waveguide”), consists of a special nickel-alloy tube.

A copper conductor is introduced through the length of this tube. The start of measurement is initiated by a short current pulse.

This current generates a circular magnetic field which rotates around the waveguide. A permanent magnet at the point of measurement is used as the marker element, whose lines of field run at right angles to the electromagnetic field. In the area on the waveguide where the two fields intersect, a magneto-strictive effect causes an elastic deformation of the waveguide, which propagates along the wave guide in both directions in the form of a mechanical wave.

The propagation velocity of this wave in the waveguide is 2830 m/s, and is nearly insensitive to environmental effects (e.g., temperature, shock, contamination).

The component of the wave which reaches the far end of the waveguide is damped there, whereas the component which arrives at the signal converter is changed into an electrical

signal by reversing the magnetostrictive effect. The wave travel time from its point of origin to the signal converter is directly proportional to the distance between the permanent magnet and the signal converter. A time measurement then allows the distance to be determined with extremely high accuracy.

**Design**

The transducers are made to the same safety and reliability standards for use in the harshest conditions:

- The electronics unit is compactly designed using SMD technology. The boards are protected in a space-saving, rugged aluminum extruded housing.
- The waveguide is protected in the extruded aluminum housing.

**Quality**

Each and every transducer undergoes a specially designed, computer-controlled testing procedure which includes 100% checking of all specified data.

<b>B</b>	Tie Rod Pneumatic Cylinders
	4MA Series
	4MAJ Series
	ACVB Option
	LPSO Option
	P1D Series
	P1F Series
	2MNR Series



For inventory, lead times, and kit lookup, visit [www.pdnplu.com](http://www.pdnplu.com)



**Linear Position Sensor Option**

**Tie Rod Pneumatic Cylinders  
4MA with LPSO**

The drawings below show that the Linear Position Sensor is longer than the cylinder of the same stroke length. The sensor overhang on the head end of the cylinder, as indicated by dimension A, may be eliminated by adding stop tubing, which effectively increases the gross stroke of the cylinder. The recommended stop tube lengths are provided in the table

below for each bore size. The examples show that the electrical stroke of the sensor will always match the **net** stroke of the cylinder.

As a result of the limited sensing range of the sensor, it will overhang at the cap end of the cylinder by the amount of dimension B.

**NO STOP TUBE**

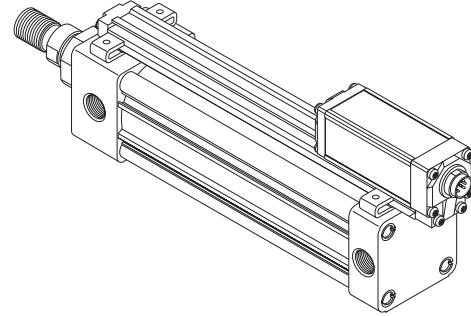
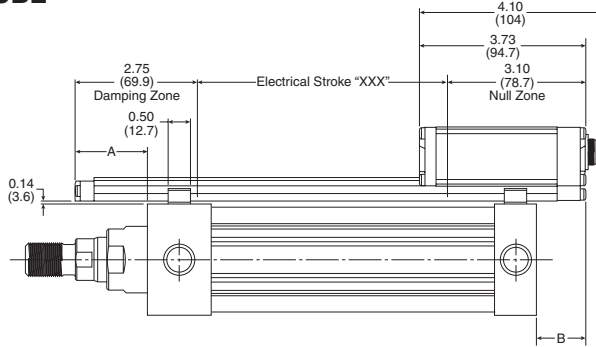

**Example A:** 12" Stroke cylinder without stop tube equals 12" Electrical Stroke for the Sensor.

**WITH STOP TUBE**

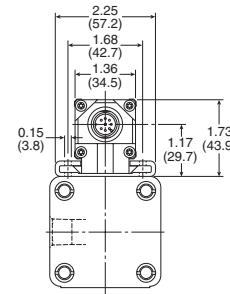
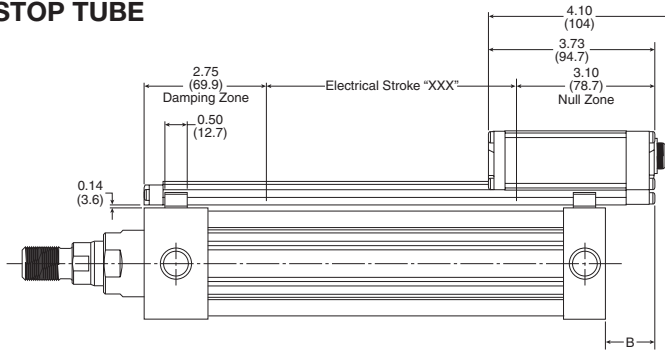

**Example B:** To eliminate sensor overhang on the head end of a 2.0" bore cylinder, add 1.0" of recommended stop tube length. The cylinder gross stroke becomes 13" and the net stroke remains 12". Specify a sensor with an electrical stroke of 12". Note that the electrical stroke equals cylinder **net** stroke length.

**Example C:** To eliminate sensor overhang on the head end of a 5.0" bore cylinder, add 0.625" of recommended stop tube length. The cylinder gross stroke becomes 12.625" and the net stroke remains 12". Specify a sensor with an electrical stroke of 12". Note that the electrical stroke equals cylinder **net** stroke length.

Bore	Rod Code	Rod Diameter	No Stop Tube		With Stop Tube		
			A	B	Stop Tube Length	A <sub>1</sub>	B
2	1	5/8	0.95	1.3	1.0	0	1.3
	3	1					
2-1/2	1	5/8	0.90	1.25	1.0	0	1.25
	3	1					
3-1/4	1	1	0.64	1.0	0.75	0	1.0
	3	1-3/8					
4	1	1	0.63	0.99	0.75	0	0.99
	3	1-3/8					
5	1	1	0.55	0.79	0.625	0	0.79
	3	1-3/8					
6	1	1-3/8	0.47	0.46	0.50	0	0.45
	3	1-3/4					
8	1	1-3/8	0.28	0.44	0.375	0	0.44
	3	1-3/4					

**B**  
Tie Rod Pneumatic  
Cylinders  
4MA  
Series  
4MAJ  
Series  
ACVB  
Option  
LPSO  
Option  
P1D  
Series  
P1F  
Series  
2MNR  
Series



For inventory, lead times, and kit lookup, visit [www.pdnplu.com](http://www.pdnplu.com)

**Analog Interface Profile Series**

**Tie Rod Pneumatic Cylinders  
4MA with LPSO**

Output signal
Transducer interface
Input interface

analog
<b>A</b>
analog

analog
<b>E</b>
analog

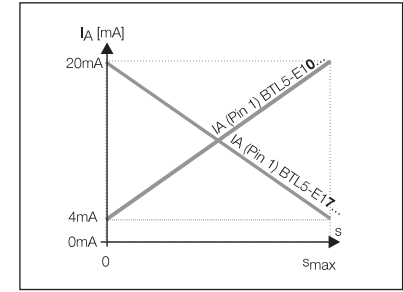
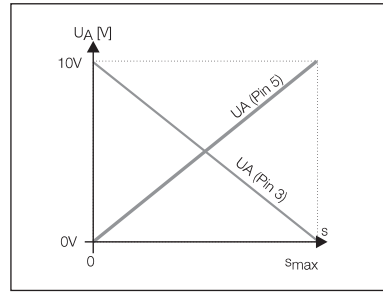

Ordering code

BTL5-A11-M-\_\_-RSU022S32

BTL5-E1-M-\_\_-RSU022S32

Output voltage

**0...10 V**

**4...20 mA**

Output current

max. 10 mA

≤ 500 Ohm

Load current

≤ 5 mV

≤ 0.2 μA

Max. ripple

Load resistance

System resolution

≤ 0.1 mV

≤ 4 μm

Hysteresis

Repeatability

Output update rate

Max. non-linearity

Temperature coefficient	Voltage output
	Current output

6 μm (hysteresis + resolution)

STANDARD = 1 ms <sup>≤</sup>1400 mm

±100 μm to 500 mm stroke

±0.02 % 501...3606 mm stroke

[150 μV/°C + (5 ppm/°C x PxU/L)] x DDT

[0.6 μA/°C + (10 ppm/°C x PxI/L)] x DT

Shock loading

100 g/11 ms per IEC 68-2-27

Vibration

12 g, 10...2000 Hz per IEC 68-2-6

Traverse velocity of magnet

any

Operating voltage

24 V DC ± 20%

Current draw

≤ 150 mA

Polarity reversal protected

yes

Overvoltage protection

Transzorb protection diodes

Dielectric constant

500 V (Ground to housing)

Operating temperature

-40...185 °F (-40...85°C)

Storage temperature

-40...212 °F (-40...100°C)

S32 Pin assignments	Pin	Color
Output signals	1	YE
	2	GY
	3	PK
	5	GN
Supply voltage	6	BU
	7	BN
	8	WH

BTL5-A11...
not used
signal GND
10...0 V
0...10 V
GND
+24 V DC
(GND)

BTL5-E1...BTL5-E7...	
4...20 mA	20...4 mA
0 V output	
10...0 V	
0...10 V	
GND	
+24 V DC	
(GND)	

Connect shield to housing.

Specifications subject to change.

Please enter code for output signal and nominal stroke in ordering code.

BTL transducers with analog outputs are available in the ranges of 0...10V, 4...20mA with rising or falling signal.

Ordering Sample:

**BTL5-A11-M-\_\_-R-SU 022S32**

**Output signal**

- 1 increasing and decreasing (for A)
- 0 increasing
- 7 decreasing (for E)

**Standard stroke lengths (mm)**



For inventory, lead times, and kit lookup, visit [www.pdnplu.com](http://www.pdnplu.com)

**M Interface**

Differential **START/STOP** control-specific interface.

**P Interface**

Compatible with BTA processors and various OEM controls. Reliable signal transmission, even over cable lengths up to 500 m (1640 ft.) between BTA and BTL, is assured by the especially noise-immune RS485 differential drivers and receivers. Noise signals are effectively suppressed.

**B**

Tie Rod Pneumatic Cylinders

Series 4MA

Series 4MAJ

Option ACVB

Option LPSO

Series P1D

Series P1F

Series 2MNR

Series			
Transducer interface			
User interface			
Ordering code			
System resolution	Process-dependent/control dependent		
Repeatability	Hysteresis + Resolution		
Resolution	≤ 2 μm		
Hysteresis	≤ 4 μm		
Standard sampling rate	STANDARD = 1 kHz ≤1400 mm		
Max. non-linearity	±100 μm to 500 mm nominal stroke ±0.02 % 501...3750 mm nominal stroke		
Temperature coefficient of overall system	(6 μm + 5 ppm x L)/°C		
Traverse velocity of magnet	any		
Operating voltage	24 V DC ±20 % or ±15V DC ±2% (optional)		
Current draw	≤ 100 mA		
Operating temperature	-40...185 °F (-40...85°C)		
Storage temperature	-40...212 °F (-40...100°C)		
S32 Pin assignments	Pin	Color	
Input/output signals	Input	1	YE
	Output	2	GY
	Input	3	PK
	Output	5	GN
Supply voltage	6	BU	
	7	BN	
	8	WH	

Shield connected to housing

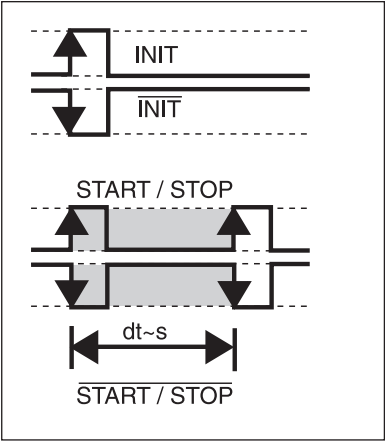
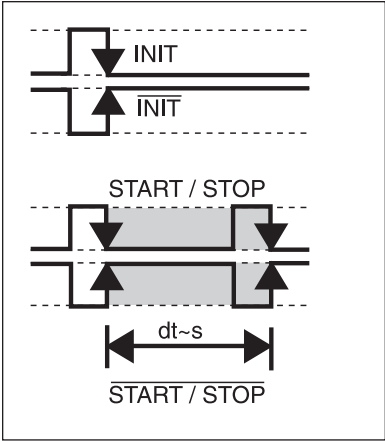
BTL5 Low Profile	BTL5 Low Profile
pulse <b>M</b>	pulse <b>P</b>
pulse <b>M</b>	pulse <b>P</b>
	
BTL5- <b>M</b> 1-M___-RSU022S32	BTL5- <b>P</b> 1-M___-RSU022S32
BTL5- <b>M</b> 1-M...	BTL5- <b>P</b> 1-M...
INIT	INIT
START/STOP	START/STOP
INIT	INIT
START/STOP	START/STOP
GND	GND
+24 V DC	+24 V DC
(GND)	(GND)

Specifications subject to change.

Please enter code for nominal stroke in ordering code.

Ordering Sample:

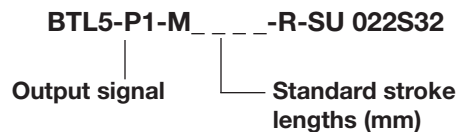

For inventory, lead times, and kit lookup, visit [www.pdnplu.com](http://www.pdnplu.com)

Sensor Ordering Code

**BTL-5** - **A** **1** **1** - **M** **0305** - **R** **SU022** **S32**

Output Signal	
<b>A</b>	0...10V
<b>E</b>	4...20mA
<b>M</b>	Differential Start/Stop, Leading Edge Active
<b>P</b>	Differential Start/Stop, Trailing Edge Active

Nominal Stroke	
Specify whole mm using 4 digits, i.e. 0305 = 305mm active electrical stroke*	
* Electrical stroke = net cylinder stroke.	

Connection Type	
<b>S32</b>	8-pin Quick Disconnect Metal Connector
<b>KA05</b>	Integral Axial Cable (specify cable length in whole meters using 2 digits, i.e. 05 = 5m)

Supply Voltage	
<b>1</b>	24 V ±20%

Housing Geometry	
<b>R</b>	Low Profile Extrusion

Output Signal (Analog only)	
<b>1</b>	Vmin or Vmax at Connector End, i.e. user selectable rising or falling*
<b>0</b>	Imin at Connector End (rising toward opposite end)**
<b>7</b>	Imax at Connector End (falling toward opposite end)**

\* Available only with 0...10V output signal (A).  
\*\* Available only with 4...20mA output signal (E).

**Please see page B3 or B19 to order 4MA cylinder configuration.**

Standard Lengths

Electrical Stroke

inches	mm
2	0051
3	0077
4	0102
5	0127
6	0152
7	0178
8	0203
9	0230
10	0254
11	0280
12	0305
13	0330

inches	mm
15	0381
16	0407
18	0457
20	0508
22	0560
24	0610
26	0661
28	0711
30	0762
32	0813
36	0914
40	1016

inches	mm
42	1067
48	1220
50	1270
60	1524
70	1778
80	2032
90	2286
100	2540
110	2794
120	3048

S32 Cables

Length

5M	BKS-S32M-05
10M	BKS-S32M-10

<b>B</b>	Tie Rod Pneumatic Cylinders
4MA	Series
4MAJ	Series
ACVB	Option
LPSO	Option
P1D	Series
P1F	Series
2MNR	Series



For inventory, lead times, and kit lookup, visit [www.pdnplu.com](http://www.pdnplu.com)

**Parker “Style 55” Piston Rod End**

Rod end flange coupling for Parker 4MA, 4ML and 4MAJ Series cylinders:

- Simplifies alignment
- Reduces assembly time
- Allows full rated pneumatic pressure in push and pull directions
- Available in 5/8" through 1-3/4" piston rod diameters

**How To Order**

Complete Model Number and place a “55” in the Piston Rod End designator position.

Example: 2.00 CJ4MAJU155C 6.000

Consult factory for availability of mounting accessories and hardware.

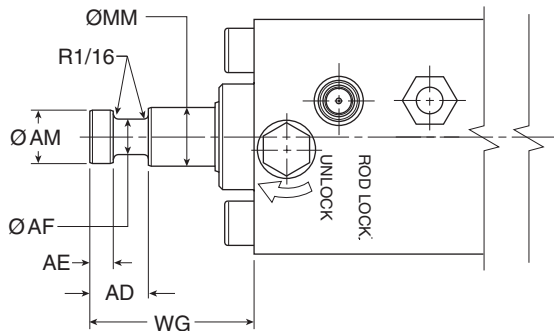

**Example:** Style 55 Rod End shown on 4MAJ Series cylinder

**Style 55 Rod End Dimensions**

Rod Dia. MM	AD	AE	AF	AM	WG
5/8	5/8	1/4	3/8	.57	1-3/4
1	0.936	3/8	11/16	.95	2-3/8
1-3/8	1-1/16	3/8	7/8	1.32	2-3/4
1-3/4	1-5/16	1/2	1-1/8	1.70	3-1/8

See 4MA or 4MAJ Series sections for more dimensions.

**Metric Rod Threads**

Standard metric thread sizes for piston rod thread type M.

Rod Dia. MM	Styles 4 & 9 KK	Style 8 CC
3/8	M6 x 1.0	M8 x 1.25
1/2	M8 x 1.25	M12 x 1.25
5/8	M10 x 1.5	M12 x 1.5
1	M20 x 1.5	M22 x 1.5
1-3/8	M26 x 1.5	M30 x 2.0
1-3/4	M33 x 2.0	M39 x 2.0

**NOTE:** All other rod end dimensions are standard per catalog.

**B**  
 Tie Rod Pneumatic Cylinders  
 4MA Series  
 4MAJ Series  
 ACVB Option  
 LPSO Option  
 P1D Series  
 P1F Series  
 2MNR Series

**Check Seal Cushions**

**For Increased Productivity and Maximum Performance**

The check seal cushion is new and different from ordinary cushion designs. It combines the sealing capabilities of a lipseal for efficient capture of air to effectively cushion and to provide check valve action for quick stroke reversal.

The design also provides “floating cushions” to assure cushion repeatability and long life. At the start of the stroke in each direction, the check valve design allows full flow to piston face with a minimum pressure drop for a maximum power stroke.

Additional benefits of the new check seal cushions are increased productivity and top performance for faster cycle time, minimum wear, easy adjustment and low pressure drop.

The basic cushion design is available at both ends without change in envelope or mounting dimensions. A captive cushion adjusting needle is supplied for easy, precise adjustment on all bore sizes.

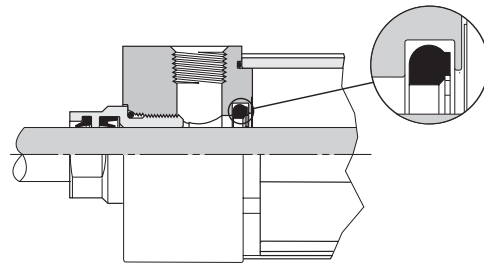

**Bumpers**

Impact dampening conventional bumpers can be provided on one or both sides of the piston with a 1/4" stroke loss per bumper. This style of bumper is ideal for applications subjected to high speeds where cycle time may discourage the use of cushions.

Available in 1-1/2" - 4" bore sizes for 4MA, 4ML and 4MAJ Series cylinders.

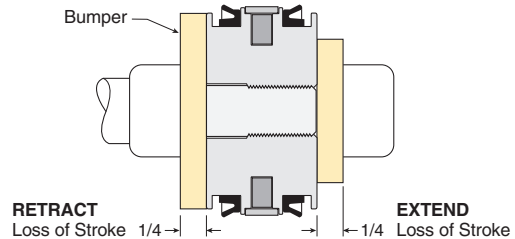

**HI LOAD Gland Assembly**

Applications with inherent side load require a slide package for maximum service life. In some cases, there may be limitations to the size or expense of these additional components. One possible solution may be the use of the optional HI LOAD gland assembly that incorporates a high strength composite bearing for radial load conditions. Extensive testing showed an approximate 50% increase in service life for general applications. Please note that each application is unique and results may vary. Includes seal options for standard, high and low temperature applications with air (4MA) or hydraulic (4ML) service.

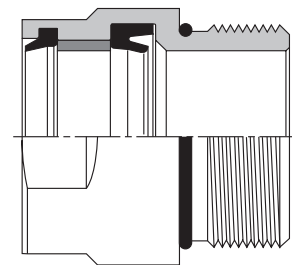

<b>B</b>
Tie Rod Pneumatic Cylinders
4MA Series
4MAJ Series
ACVB Option
LPSO Option
P1D Series
P1F Series
2MNR Series

**Bumper Seal Option**

Impact dampening Bumper Seals are now optional on all 4MA and 4MAJ cylinders from 1-1/2" to 5" bore. The Bumper Seal piston combines the features of low-friction, rounded lipseals and impact-dampening bumpers to provide reduced noise and smoother end-of-stroke deceleration. At pressure greater than 80 PSI, the compressible Buna Nitrile or Fluorocarbon Bumper Seal has minimal effect on stroke loss. When specified, Bumper Seals will be supplied on both ends of the piston, eliminating the need to specify head end or cap end only.

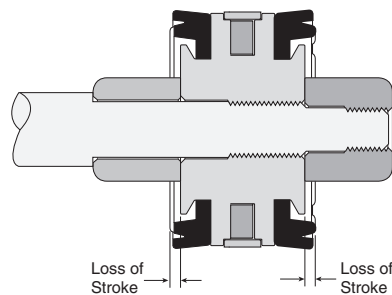

**Summary of Accelerometer Test Results**

Bore Size	Piston Type	Cushioning Efficiency (Maximum G's of Deceleration Force Created)	Cushioning Time (ms)
1-1/2"	Standard Piston	13.4	22
	Bumper Seal Piston	5.1	22
2"	Standard Piston	12.6	33
	Bumper Seal Piston	7.8	26
2-1/2"	Standard Piston	12.2	36
	Bumper Seal Piston	5.2	24

**Bumper Seals Reduce Noise**

The special profile of the Bumper Seal prevents the piston from noisily banging into the end cap at the end of stroke. Independent testing shows that the Bumper Seal, when combined with cushions, will absorb the final piston inertia and reduce the stroke noise by as much as 20 dB. The Sound Level Comparison graph illustrates the noise-reducing effects of the Bumper Seal piston when combined with cushions.

Impact noise was recorded at a distance of 3 feet from the front of the cylinder, inside a semi-anechoic chamber. Cylinders were operating at 95 PSI.

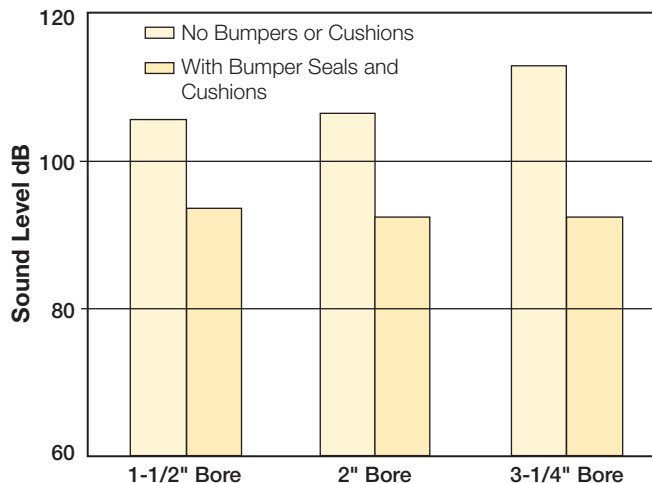

**Sound Level Comparison**

**Bumper Seals have Minimum Effect on Stroke Length**

The accompanying chart depicts typical amounts of overall stroke loss incurred at various system pressures. The amount of stroke loss may vary slightly due to design tolerances of seal size, variance in seal durometer and compression set associated with cylinder wear. To determine the stroke loss at either end of the cylinder, divide the values by two.

Pressure (PSI)	Typical Overall Loss of Stroke (inch) by Bore Size				
	1-1/2"	2"	2-1/2"	3-1/4"	4"
0	0.16	0.13	0.19	0.22	0.22
20	0.12	0.11	0.12	0.18	0.18
40	0.10	0.08	0.09	0.12	0.12
60	0.08	0.07	0.07	0.09	0.09
80	0.06	0.05	0.05	0.06	0.06
100	0.05	0.03	0.02	0.04	0.04

**B**  
 Tie Rod Pneumatic Cylinders  
 4MA Series  
 4MAJ Series  
 ACVB Option  
 LPSO Option  
 P1D Series  
 P1F Series  
 2MNR Series



For inventory, lead times, and kit lookup, visit [www.pdnplu.com](http://www.pdnplu.com)



**1-1/2" to 8" Bore Cylinder Accessories**

Rod end accessories can be selected by cylinder rod end thread size from Table A & B below. Mating parts for rod end accessories are listed just to the right of the knuckle or clevis selected. Mounting plates for style MP1 & MP4 cylinder mounts are selected by bore size from Table C.

Rod End Thread Size	TABLE A			TABLE B			TABLE C		
	Female Rod Clevis	Eye Bracket	Pivot Pin	Knuckle	Clevis Bracket	Pivot Pin	Bore Size	For Mtg. Style MP1 Cylinder	For Mtg. Style MP4 Cylinder
7/16-20	1458030044	1458060050	0856640044	1458040044	1458050050	0856640044	1-1/2	1458060050	1458050050
1/2-20	1458030050	1458060050	0683680000	1458040050	1458050050	0683680000	2	1458060050	1458050050
3/4-16	1458030075	1458060075	0683690000	1458040075	1458050075	0683690000	2-1/2	1458060050	1458050050
7/8-14	1458030088	1458060100	0683700000	1458040088	1458050100	0683700000	3-1/4	1458060075	1458050075
1-14	1458030100	1458060100	0683700000	1458040100	1458050100	0683700000	4	1458060075	1458050075
1-1/4-12	1458030125	1458060138	0683710000	1458040125	1458050138	0683710000	5	1458060075	—
1-1/2-12	1458030150	1458060175	0683720000	1458040150	1458050175	0683720000	6	1458060100	—
							8	1458060100	—

**Pivot Pin**

**Note:** Pivot Pin must be ordered separately for single lug pivot mounting.

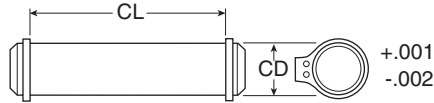

Symbol	0856640044	0683680000	0683690000	0683700000	0683710000	0683720000
CD	7/16	1/2	3/4	1	1-3/8	1-3/4
CL	1-5/16	1-7/8	2-5/8	3-1/8	4-1/8	5-3/16
Shear Cap. (lbs)	6600	8600	19300	34300	65000	105200

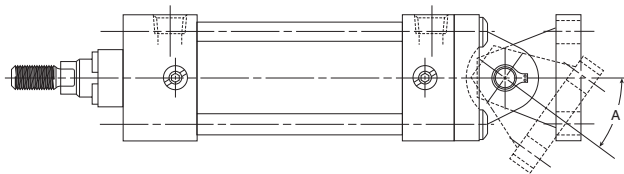

**Maximum Pivot Angle for Rear Clevis Mounts (BB Mounts) and Accessories**

Bore	1-1/2	2	2-1/2	3-1/4	4	5	6	8
Angle A	52	43	29	50	49	45	42	42

**B**

Tie Rod Pneumatic Cylinders

4MA Series

4MAJ Series

ACVB Option

LPSO Option

P1D Series

P1F Series

2MNR Series



**Female Rod Clevis**

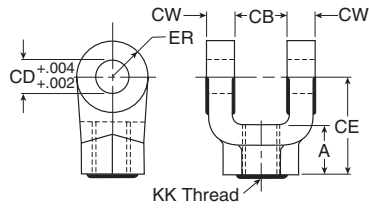

Symbol	1458030044	1458030050	1458030075	1458030088	1458030100	1458030125	1458030150
A	3/4	3/4	1-1/8	1-5/8	1-5/8	2	2-1/4
CB	3/4	3/4	1-1/4	1-1/2	1-1/2	2	2-1/2
CD	1/2	1/2	3/4	1	1	1-3/8	1-3/4
CE	1-1/2	1-1/2	2-1/8	2-15/16	2-15/16	3-3/4	4-1/2
CW	1/2	1/2	5/8	3/4	3/4	1	1-1/4
ER	1/2	1/2	3/4	1	1	1-3/8	1-3/4
KK	7/16-20	1/2-20	3/4-16	7/8-14	1-14	1-1/4-12	1-1/2-12
<b>Load Capacity (lbs)</b>	4250	4900	11200	18800	19500	33500	45600

**Rod Eye Knuckle**

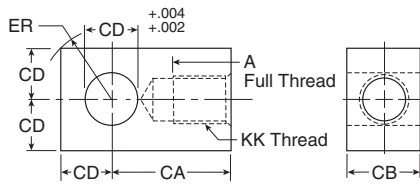

Symbol	1458040044	1458040050	1458040075	1458040088	1458040100	1458040125	1458040150
A	3/4	3/4	1-1/8	1-1/8	1-5/8	2	2-1/4
CA	1-1/2	1-1/2	2-1/16	2-3/8	2-13/16	3-7/16	4
CB	3/4	3/4	1-1/4	1-1/2	1-1/2	2	2-1/2
CD	1/2	1/2	3/4	1	1	1-3/8	1-3/4
ER	23/32	23/32	1-1/16	1-7/16	1-7/16	1-31/32	2-1/2
KK	7/16-20	1/2-20	3/4-16	7/8-14	1-14	1-1/4-12	1-1/2-12
<b>Load Capacity (lbs)</b>	5000	5700	12100	13000	21700	33500	45000

**Clevis Bracket**

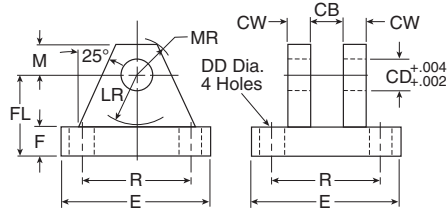

Symbol	1458050050	1458050075	1458050100	1458050138	1458050175
CB	3/4	1-1/4	1-1/2	2	2-1/2
CD	1/2	3/4	1	1-3/8	1-3/4
CW	1/2	5/8	3/4	1	1-1/4
DD	13/32	17/32	21/32	21/32	29/32
E	3-1/2	5	6-1/2	7-1/2	9-1/2
F	1/2	5/8	3/4	7/8	7/8
FL	1-1/2	1-7/8	2-1/4	3	3-5/8
LR	3/4	1-3/16	1-1/2	2	2-3/4
M	1/2	3/4	1	1-3/8	1-3/4
MR	5/8	29/32	1-1/4	1-21/32	2-7/32
R	2.55	3.82	4.95	5.73	7.50
<b>Load Capacity (lbs)</b>	7300	14000	19200	36900	34000

\* Wall mount - will not mount directly to rear of cylinder.

**Mounting Plate & Eye Bracket**

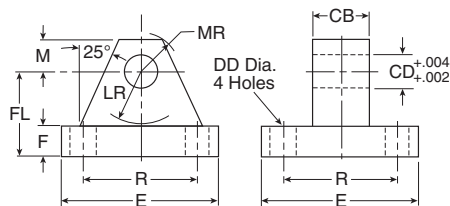

Symbol	1458060050	1458060075	1458060100	1458060138	1458060175
CB	3/4	1-1/4	1-1/2	2	2-1/2
CD	1/2	3/4	1	1-3/8	1-3/4
DD	13/32	17/32	21/32	21/32	29/32
E	2-1/2	3-1/2	4-1/2	5	6-1/2
F	3/8	5/8	7/8	7/8	1-1/8
FL	1-1/8	1-7/8	2-3/8	3	3-3/8
LR	3/4	1-1/4	1-1/2	2-1/8	2-1/4
M	1/2	3/4	1	1-3/8	1-3/4
MR	9/16	7/8	1-1/4	1-5/8	2-1/8
R	1.63	2.55	3.25	3.82	4.95
<b>Load Capacity (lbs)</b>	4100	10500	20400	21200	49480

\* Wall mount - will not mount directly to rear of cylinder.

**B**  
 Tie Rod Pneumatic Cylinders  
 4MA Series  
 4MAJ Series  
 ACVB Option  
 LPSO Option  
 P1D Series  
 P1F Series  
 2MNR Series



For inventory, lead times, and kit lookup, visit [www.pdnplu.com](http://www.pdnplu.com)

**Mounting Kit Assembly**

Perform the following steps when installing mounting kits onto 1-1/2" - 5" bore 4MA and 4ML cylinders with the standard mount (TE or TEF).

1. Clean mating parts to remove oil, grease and dirt.
2. Fasteners should be clean, dry and burr free.
3. Brush mounting fastener threads thoroughly with anti-seize lubricant.
4. Follow the appropriate procedure below for the desired mounting.

**Rear Pivot Mounting Kits – Styles BB, BC and BE (Fig. 1)**

Place pivot mount over end cap, lining up the four fastener holes in the end cap with the pivot mounting plate. Note that the pivot mount can be rotated allowing for different cylinder port locations. Secure mounting to cylinder cap (finger tight) using the four fasteners. Torque the fasteners to the specifications in the table below.

**End Angle Mounting Kit – Styles CB (Fig. 2)**

The end angles bolt to the front and rear of the cylinder end caps. The spacer plate\*\* provided is to be assembled at the rod end under the angle plate. Line up the two holes of the spacer plate and angle plate with the two fastener holes in the cylinder head. If 2 different length fasteners are in the kit, use the longer fasteners for the cylinder head end (rod end) mount. Secure (finger tight) using two fasteners. Repeat this assembly at the opposite end (less spacer). Place the assembly with the end angles down on a flat surface and torque the four fasteners to the specifications shown in the table below.

**Flange Mounting Kits – Styles J and H Single and Double Rod Cylinders (Fig. 3)**

Place rectangular flange plate over appropriate end cap. Line up the four holes in the mounting plate with the four fastener holes in the cylinder end cap. Note that the rectangular mounting plate can be rotated to allow for different port locations. Secure the rectangular mounting plate to the end cap (finger tight) using the four fasteners. Then torque the four fasteners to the specifications shown in the table below.

**Side End Lug Mounting Kits – Style G (Fig. 4)**

Attach the two longer lugs with the fasteners provided in the kit to the cylinder head as shown. Attach the two shorter lugs to the cylinder cap in a similar fashion. Place the assembly with the lugs down on a flat surface and torque the four fasteners to the specifications shown in the table below.

Fig. 1 - Pivot Mounting Kit

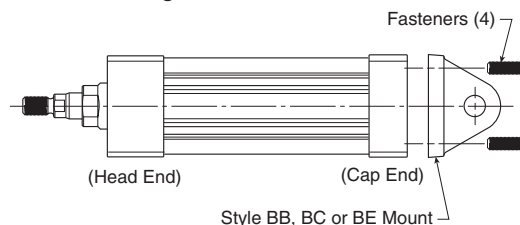

Fig. 2 - End Angle Mounting Kit

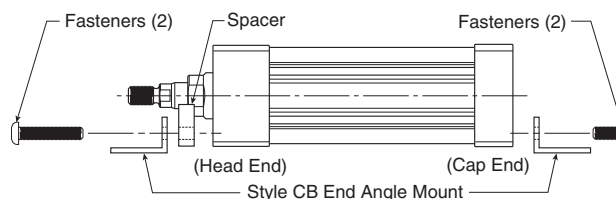

Fig. 3 - Flange Mounting Kit

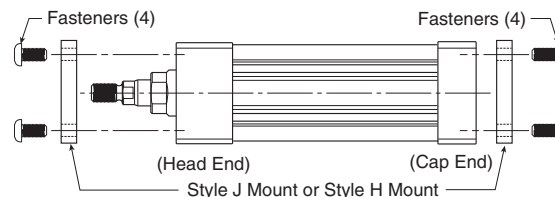
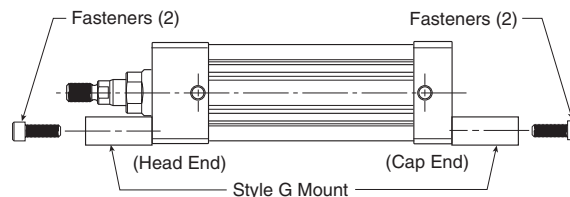

Fig. 4 - Side End Lug Mounting Kit - Style MS7



**Mounting Kits**

Bore Size	J (MF1)	H (MF2)	BB (MP1)	BC (MP2)	BE (MP4)	CB (MS1)	G (MS7)	Kit Fastener Torque Units	
	Head Rectangular Flange	Cap Rectangular Flange	Cap Fixed Clevis	Cap Detachable Clevis	Cap Detachable Eye	Side End Angles	Side End Lug	USA	Metric
	Kit Number	Kit Number	Kit Number	Kit Number	Kit Number	Kit Number	Kit Number	inch-lbs	Nm
1-1/2	L079700150	L079700150	L079710150	L079730150	L079720150	L079740150	L079750150	32 - 36	3.6 - 4.1
2	L079700200	L079700200	L079710200	L079730200	L079720200	L079740200	L079750200	72 - 82	8 - 9
2-1/2	L079700250	L079700250	L079710250	L079730250	L079720250	L079740250	L079750250	72 - 82	8 - 9
3-1/4	L079700325	L079700325	L079710325	L079730325	L079720325	L079740325	L079750325	216 - 228	24 - 25.3
4	L079700400	L079700400	L079710400	L079730400	L079720400	L079740400	L079750400	216 - 228	24 - 25.3
5	L079700500	L079700500	L079710500	L079730500	N/A	L079740500	N/A	360 - 372	41 - 42

\*\* Spacer plate not used for 4" bore or double rod cylinders

**B**  
Tie Rod Pneumatic Cylinders  
4MA Series  
4MAJ Series  
ACVB Option  
LPSO Option  
PID Series  
PIF Series  
2MNR Series



For inventory, lead times, and kit lookup, visit [www.pdnplu.com](http://www.pdnplu.com)

**Gland Kits (Gland cartridges and rod seals)**

**Pneumatic service only**

Temperatures:

- Nitrile -10°F to 165°F (-23°C to 74°C)
- Fluorocarbon -10°F to 250°F (-23°C to 121°C)

**Servicing the rod gland (Cylinder disassembly is not required)**

Air leakage around the piston rod at the gland area will normally indicate a need to replace the gland cartridge.

The Parker 4MA gland is a unique cartridge design. It is threaded into the cylinder head and all sizes are removable without disturbing the endcap fasteners.

**To remove the old gland cartridge from the cylinder:**

1. Inspect the piston rod to be sure it is free of burrs or other foreign material that would prevent sliding the gland off the rod.
2. Disconnect any attachments to the piston rod end thread.
3. Lubricate the rod with Lube-A-Cyl (included in kit).
4. Unscrew the gland cartridge from the head using the appropriate wrench (see D1 dimension in catalog).
5. Slide the gland cartridge off the piston rod.
6. Verify that the gland-to-head o-ring (#45) is also removed from the head.

**To install the new gland cartridge onto the cylinder:**

1. Re-inspect the surface of the piston rod for scratches, dents and other surface damage, and repair if necessary.
2. Clean and lubricate the surface of the piston rod with Lube-A-Cyl (included in kit).
3. Lubricate the rod wiper (#40), rod seal (#41), o-ring (#45) and the inside surfaces of the gland cartridge with Lube-A-Cyl.
4. Slide the gland cartridge onto the piston rod, align it with the threads in the head, and tighten (clockwise) until seated firmly against the head.
5. Torque the gland cartridge to the specifications shown below. Tools are available to assist this process (see below).

**Note:** Make sure the gland cartridge is sufficiently tight. Failure to do so may result in loosening during operation.

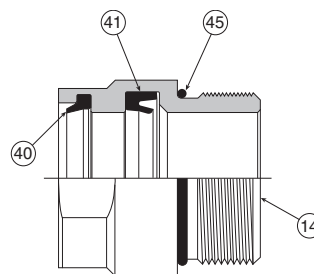

**Standard Rod Gland**

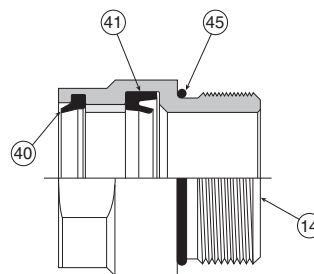

**HI LOAD Rod Gland  
(includes composite bearing)**

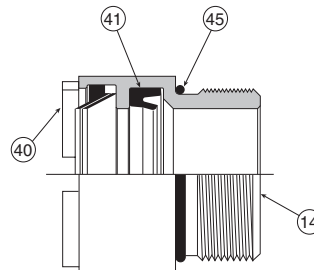

**Metallic Rod Wiper Gland**

Every gland cartridge kit contains 1 each of the following:

Symbol	Description
14	Gland
40	Rod Wiper
41	Rod Seal
45	O-ring - Gland to head

Rod Dia.	Standard & HI LOAD Gland		Metallic Rod Wiper Gland	
	Gland Wrench		Gland Wrench	Spanner Wrench
5/8	0695800000		0695900000	0116760000
1	0695810000		0695910000	0116760000
1-3/8	0695820000		0695920000	0117030000
1-3/4	0695830000		0695930000	0116770000

Bore size	Rod dia.	Rod no.	Standard Rod Gland Cartridge Kit Includes 1 Each Of Symbol 14, 40, 41 & 45		HI LOAD Rod Gland Cartridge Kit Includes 1 Each Of Symbol 14, 40, 41 & 45		Metallic Rod Wiper Gland Cartridge Kit Includes 1 Each Of Symbol 14, 40, 41 & 45		Gland to Head Torque Units	
			Nitrile Seals Kit Number	Fluorocarbon Seals Kit Number	Nitrile Seals Kit Number	Fluorocarbon Seals Kit Number	Nitrile & Pur Seals Kit Number	Seals Kit Number	USA Ft-Lbs	Metric N-M
1-1/2	5/8	1	RG04MA0061	RG04MA0065	RG04MAH061	RG04MAH065	RG04MAM061	RG04MAM065	40 - 45	54 - 61
		2	RG04MA0101	RG04MA0105	RG04MAH101	RG04MAH105	RG04MAM101	RG04MAM105	45 - 50	61 - 68
2	5/8	1	RG04MA0061	RG04MA0065	RG04MAH061	RG04MAH065	RG04MAM061	RG04MAM065	40 - 45	54 - 61
		3	RG04MA0101	RG04MA0105	RG04MAH101	RG04MAH105	RG04MAM101	RG04MAM105	45 - 50	61 - 68
2-1/2	5/8	1	RG04MA0061	RG04MA0065	RG04MAH061	RG04MAH065	RG04MAM061	RG04MAM065	40 - 45	54 - 61
		3	RG04MA0101	RG04MA0105	RG04MAH101	RG04MAH105	RG04MAM101	RG04MAM105	45 - 50	61 - 68
3-1/4	1-3/8	1	RG04MA0131	RG04MA0135	RG04MAH131	RG04MAH135	RG04MAM131	RG04MAM135	75 - 80	102 - 108
		3	RG04MA0101	RG04MA0105	RG04MAH101	RG04MAH105	RG04MAM101	RG04MAM105	45 - 50	61 - 68
4	1-3/8	1	RG04MA0131	RG04MA0135	RG04MAH131	RG04MAH135	RG04MAM131	RG04MAM135	75 - 80	102 - 108
		3	RG04MA0101	RG04MA0105	RG04MAH101	RG04MAH105	RG04MAM101	RG04MAM105	45 - 50	61 - 68
5	1-3/8	1	RG04MA0131	RG04MA0135	RG04MAH131	RG04MAH135	RG04MAM131	RG04MAM135	75 - 80	102 - 108
		3	RG04MA0101	RG04MA0105	RG04MAH101	RG04MAH105	RG04MAM101	RG04MAM105	45 - 50	61 - 68
6	1-3/8	1	RG04MA0131	RG04MA0135	RG04MAH131	RG04MAH135	RG04MAM131	RG04MAM135	75 - 80	102 - 108
		3	RG04MA0171	RG04MA0175	RG04MAH171	RG04MAH175	RG04MAM171	RG04MAM175	90 - 95	122 - 129
8	1-3/8	1	RG04MA0131	RG04MA0135	RG04MAH131	RG04MAH135	RG04MAM131	RG04MAM135	75 - 80	102 - 108
		3	RG04MA0171	RG04MA0175	RG04MAH171	RG04MAH175	RG04MAM171	RG04MAM175	90 - 95	122 - 129



For inventory, lead times, and kit lookup, visit [www.pdnplu.com](http://www.pdnplu.com)

**Piston Seal Kits (Piston and cylinder body seals)**

**Pneumatic service only**

Temperatures:

- Nitrile -10°F to 165°F (-23°C to 74°C)
- Fluorocarbon -10°F to 250°F (-23°C to 121°C)

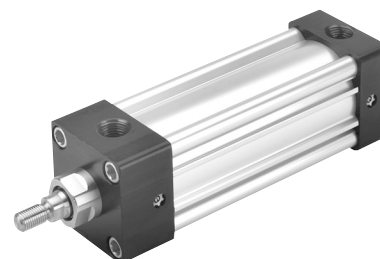
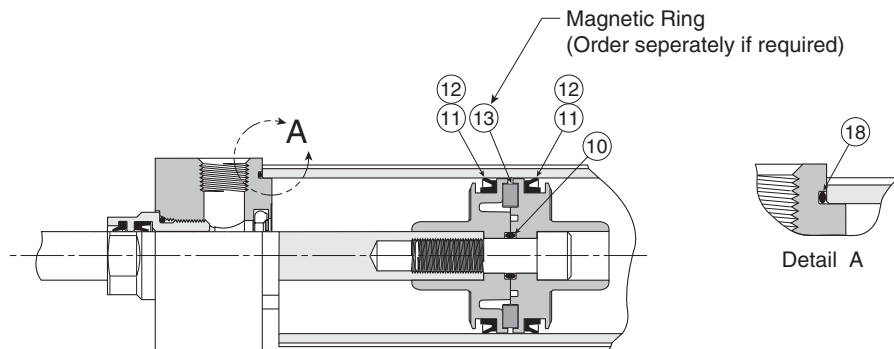

Composite piston assembly shown above.  
Aluminum piston options available.  
The same piston lipseals fit both piston types.

**Servicing the piston seals – see next page**

**Warning** – The piston rod (or fastener) to piston threaded connection is secured with an anaerobic adhesive that is temperature sensitive. Cylinders specified with all fluorocarbon seals are assembled with an anaerobic adhesive having a maximum operating temperature rating of 250°F (121°C). Cylinders specified with other seal compounds are assembled with an anaerobic adhesive having a maximum operating temperature rating of 165°F (74°C). These temperature limitations are necessary to prevent possible loosening of the threaded connections. Cylinders originally manufactured with Class 1 seals (Nitrile) that will be exposed to ambient temperatures above 165°F (74°C) must be modified for higher temperature service. Contact pdnapps@parker.com immediately and arrange for the piston to rod connection to be properly re-assembled to withstand the higher temperature service and other cylinder changes.

**Note:** the maximum temperature rating for the composite piston is 165°F (74°C).

**Every standard piston seal kit (PK) contains 2 of the following:**

Symbol	Description
11	Piston seal (lipseal)
18	O-ring - cylinder body to head & cap

**Every bumper piston seal kit (BK) contains 2 of the following:**

Symbol	Description
12	Piston seal (bumper seat cushion)
18	O-ring - cylinder body to head & cap

1 tube of Lube-A-Cyl is also included with each PK or BK kit.

Bore size	PK - Piston Seal Kit, Standard Lipseals Includes 2 Each Of Symbol 11 & 18 Includes Wear Band (#27) for Aluminum Pistons and 4" and 5" Composite Pistons		BK - Piston Seal Kit, Bumper Seals Includes 2 Each Of Symbol 12 & 18		Magnetic Ring (not replaceable for composite piston) Part Number	Torque Units Endcap Fastener Or Tie Rod	
	Nitrile Seals Kit Number	Fluorocarbon Seals Kit Number	Nitrile Seals Kit Number	Fluorocarbon Seals Kit Number		USA Inch-Lbs	Metric N-M
1-1/2	PK1504MA01	PK1504MA05	BK01504MA1	BK01504MA5	0865130151	32 - 36	3.6 - 4.1
2	PK2004MA01	PK2004MA05	BK02004MA1	BK02004MA5	0865130200	72 - 82	8 - 9
2-1/2	PK2504MA01	PK2504MA05	BK02504MA1	BK02504MA5	0865130250	72 - 82	8 - 9
3-1/4	PK3254MA01	PK3254MA05	BK03254MA1	BK03254MA5	0865130325	216 - 228	24 - 25.3
4	PK4004MA01	PK4004MA05	BK04004MA1	BK04004MA5	0865130400	216 - 228	24 - 25.3
5	PK5004MA01	PK5004MA05	BK05004MA1	BK05004MA5	0865130500	360 - 372	41 - 42
6	PK6004MA01	PK6004MA05	N/A	N/A	0865130600	420 - 432	48 - 49
8	PK8004MA01	PK8004MA05	N/A	N/A	0865130800	960 - 972	109 - 115



For inventory, lead times, and kit lookup, visit [www.pdnplu.com](http://www.pdnplu.com)

<b>B</b>	Tie Rod Pneumatic Cylinders
4MA	Series
4MAJ	Series
ACVB	Option
LPSO	Option
P1D	Series
P1F	Series
2MNR	Series

**Parker Lube-A-Cyl...**

Is recommended for use in air cylinders during normal operation, and particularly when servicing and reassembling cylinders. It is a multi-purpose lubricant in grease form that provides lubrication without deteriorating effects on synthetic seals. It produces a thin film which will not blow out with exhaust air. It provides piston, rod and seal lubrication, and has excellent resistance to water and mechanical breakdown with temperature range of -10°F to 350°F (-23°C to 177°C). Lube-A-Cyl is packaged in 1.5 oz. tubes, a sufficient quantity for average size air cylinder. One application should last for a period of 6 to 18 months depending upon service. Order by part number 0761630000.

**Servicing the Piston Seals**

Disassemble the cylinder completely, remove the old seals and clean all the parts. The cylinder bore and piston should then be examined for evidence of scoring. (The light scratch marks usually present on both cylinder bore and piston will generally have no detrimental effects on the performance of the cylinder.)

Apply Parker “Lube-A-Cyl” to O.D. of piston and all grooves. Install one piston Lipseal (sym. # 11 or 12) in the groove nearest the rod. The two “lips” of this seal should face toward the rod end of the piston. **Aluminum and 4" & 5" composite pistons only** – If required, install magnetic ring (sym. #13) in the bottom of the middle groove and then install wear band (sym. #27) in the top of the middle groove.

Coat the inside of the cylinder body with Parker “Lube-A-Cyl” and insert the piston – cap end first – into the cylinder body as shown in detail “2” below.

Next, turn the cylinder body on its side and push the piston and rod assembly through the barrel just far enough to expose the groove for the second Lipseal. (See detail “3” below.) For aluminum pistons, be careful not to move the piston too far so as to expose the wear strip (sym. #27). If the piston should move too far, push the piston and rod assembly completely through the cylinder body and again start the piston from the original end. Now install the second Lipseal (sym. # 11 or 12) in the exposed groove with the two “lips” facing away from the rod and pull the piston into the cylinder body.

The piston and rod are securely locked together with anaerobic adhesive. This threaded connection should only be disassembled or reassembled by factory trained personnel.

**NOTE:** An extreme pressure lubricant (such as molybdenum disulphate) should be used on the tie rod threads and bearing faces to reduce friction and tie rod twist.

Assemble both cap and head, complete with cylinder body O-Rings (sym. # 18), to each end of the cylinder body. Install end cap fasteners and tighten to appropriate torque, using opposite corner to corner torquing sequence.

In case of a “DD” – center trunnion – mounted cylinder, care must be taken to prevent binding the cylinder body when repositioning the trunnion collar. The proper method of assembling this type of cylinder is as follows:

After all the piston seals have been installed on the piston and the piston is in the cylinder body, fit the cap with its O-ring (sym. # 18) in position onto the cylinder body. Then “stud” into the trunnion collar the four tie rods that connect the cap to the trunnion collar. Hand tighten the four tie rod nuts at the cap.

Distances from the inner face of the cap to the finished face of the trunnion collar should be made equal at all four tie rods when all four tie rod nuts are in contact with the cap.

When the assembly is ready for final torquing, it may be necessary to adjust the tie rods at the cap when torquing the tie rods at the head in order to position the trunnion collar in its final position.

As a check, to be certain the trunnion mount will not interfere with cylinder operation, move the piston and rod assembly by hand to determine whether there is any tendency for the piston to bind at the spot where the trunnion collar is located. If any binding is noticeable, readjust the tie rods.

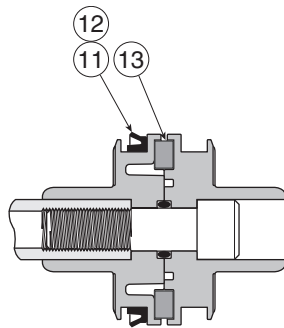

Detail “1”

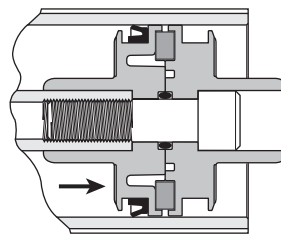

Detail “2”

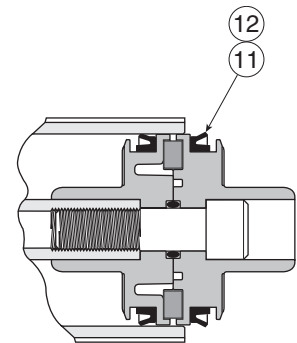

Detail “3”

B	Tie Rod Pneumatic Cylinders
	4MA Series
	4MAJ Series
	ACVB Option
	LPSO Option
	P1D Series
	P1F Series
	2MNR Series



For inventory, lead times, and kit lookup, visit [www.pdnplu.com](http://www.pdnplu.com)



**4MA Complete Cylinder Kits** (All parts to service entire cylinder)

**Pneumatic service only**

Temperatures:

- Nitrile -10°F to 165°F (-23°C to 74°C)
- Fluorocarbon -10°F to 250°F (-23°C to 121°C)

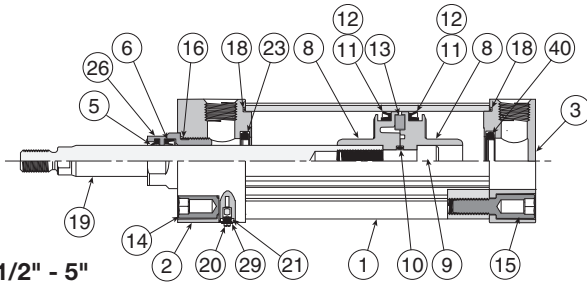

**1-1/2" - 5" Bores**

Symbol	Description
1	Cylinder body
2	Head
3	Cap
5	Rod wiper
6	Rod seal
8	Piston (composite or aluminum)
9	Piston fastener (only for composite piston)
10	O-ring - piston fastener to piston
11	Piston seal (lipseal)
12	Piston seal (Bumper seal option)
13	Magnetic ring
14	Head fastener
15	Cap fastener
16	O-ring - gland to head
18	O-ring - cylinder body to head & cap
19	Piston rod
20	Cushion needle valve
21	O-ring - cushion needle valve
22	Cushion needle valve retainer (6" & 8")
23	Cushion check seal - head
24	Tie rod nut (6" & 8" bore or Style DD mounts)
25	Head cushion sleeve
26	Gland
27	Wear band (aluminum and 4" & 5" composite pistons)
28	Tie rod (6" & 8" bore or Style DD mounts)
29	Retaining washer
40	Cushion check seal - cap

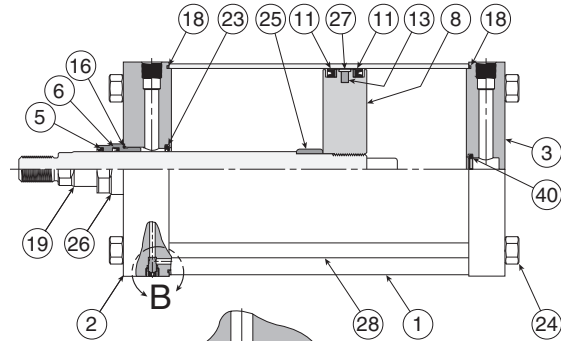
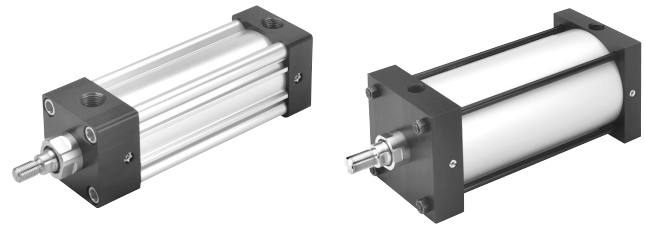

**6" - 8" Bores**

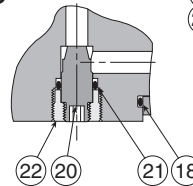

Detail B

**Servicing the complete cylinder**

This kit offers all parts to service an entire 4MA cylinder with the standard rod gland and standard piston lipseals. Kits are available with Nitrile or Fluorocarbon seals.

This kit is a combination of the Standard Gland Kit, Standard Piston Seal Kit, Head Cushion Kit and Cap Cushion Kit. The kits can service cylinders with either the composite or aluminum piston (lipseal). Depending on cylinder configuration, some parts may not be used. Please refer to the pages or bulletins of these individual kits for service instructions.

1 tube of Lube-A-Cyl is also included with each SK kit.

Sk - Complete Cylinder Kit Includes 1 Each Of Standard Rod Gland Kit, Standard Piston Seal Kit, Head Cushion Kit And Cap Cushion Kit

Bore Size	Rod Dia.	Rod No.	Nitrile Seals		Fluorocarbon Seals		Gland To Head Torque Units		Endcap Fastener Or Tie Rod Torque Units	
			Kit Number	Kit Number	USA ft-lbs	Metric Nm	USA Inch-lbs	Metric Nm		
1-1/2	5/8	1	SK15104MA1	SK15104MA5	40 - 45	54 - 61	32 - 36	3.6 - 4.1		
	1	2	SK15304MA1*	SK15304MA5*	45 - 50	61 - 68				
2	5/8	1	SK20104MA1	SK20104MA5	40 - 45	54 - 61	72 - 82	8 - 9		
	1	3	SK20304MA1	SK20304MA5	45 - 50	61 - 68				
2-1/2	5/8	1	SK25104MA1	SK25104MA5	40 - 45	54 - 61	72 - 82	8 - 9		
	1	3	SK25304MA1	SK25304MA5	45 - 50	61 - 68				
3-1/4	1	1	SK32104MA1	SK32104MA5	45 - 50	61 - 68	216 - 228	24 - 25.3		
	1-3/8	3	SK32304MA1	SK32304MA5	75 - 80	102 - 108				
4	1	1	SK40104MA1	SK40104MA5	45 - 50	61 - 68	216 - 228	24 - 25.3		
	1-3/8	3	SK40304MA1	SK40304MA5	75 - 80	102 - 108				
5	1	1	SK50104MA1	SK50104MA5	45 - 50	61 - 68	360 - 372	41 - 42		
	1-3/8	3	SK50304MA1	SK50304MA5	75 - 80	102 - 108				
6	1-3/8	1	SK60104MA1	SK60104MA5	75 - 80	102 - 108	420 - 432	48 - 49		
	1-3/4	3	SK60304MA1	SK60304MA5	90 - 95	122 - 129				
8	1-3/8	1	SK80104MA1	SK80104MA5	75 - 80	102 - 108	960 - 972	109 - 115		
	1-3/4	3	SK80304MA1	SK80304MA5	90 - 95	122 - 129				

\*Does not include Head Cushion Kit (not available)

**B**

Tie Rod Pneumatic Cylinders

4MA Series

4MAJ Series

ACVB Option

LPSO Option

P1D Series

P1F Series

2MNR Series



For inventory, lead times, and kit lookup, visit [www.pdnplu.com](http://www.pdnplu.com)



**4ML Gland Kits (Gland cartridges and rod seals)**

**Hydraulic service (includes TS-2000 rod seal)**

Temperatures:

- Nitrile/Polyurethane (PUR) -10°F to 165°F (-23°C to 74°C)
- Fluorocarbon -10°F to 250°F (-23°C to 121°C)

**Servicing the rod gland (Cylinder disassembly is not required)**

Fluid leakage around the piston rod at the gland area will normally indicate a need to replace the gland cartridge.

The Parker 4ML gland is a unique cartridge design. It is threaded into the cylinder head and all sizes are removable without disturbing the endcap fasteners.

**To remove the old gland cartridge from the cylinder:**

1. Inspect the piston rod to be sure it is free of burrs or other foreign material that would prevent sliding the gland off the rod.
2. Disconnect any attachments to the piston rod end thread.
3. Lubricate the rod with clean light oil.
4. Unscrew the gland cartridge from the head using the appropriate wrench (see D1 dimension in catalog).
5. Slide the gland cartridge off the piston rod.
6. Verify that the gland-to-head o-ring (#45) is also removed from the head.

**To install the new gland cartridge onto the cylinder:**

1. Re-inspect the surface of the piston rod for scratches, dents and other surface damage, and repair if necessary.
2. Clean and lubricate the surface of the piston rod with clean light oil.
3. Lubricate the rod wiper (#40), rod seal (#41), o-ring (#45) and the inside surfaces of the gland cartridge with clean light oil.
4. Slide the gland cartridge onto the piston rod, align it with the threads in the head, and tighten (clockwise) until seated firmly against the head.
5. Torque the gland cartridge to the specifications shown below. Tools are available to assist this process (see below).

**Note:** Make sure the gland cartridge is sufficiently tight. Failure to do so may result in loosening during operation.

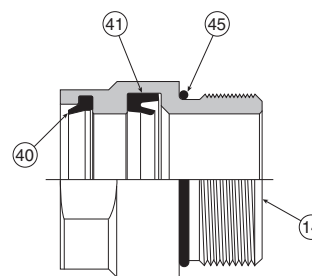

**Standard Rod Gland**

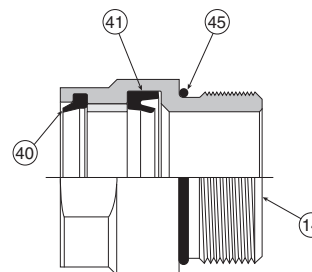

**HI LOAD Rod Gland (includes composite bearing)**

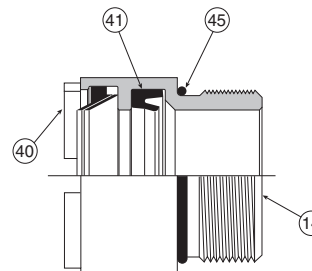

**Metallic Rod Wiper Gland**

Every gland cartridge kit contains 1 each of the following:

Symbol	Description
14	Gland
40	Rod Wiper
41	Rod Seal
45	O-ring - Gland to head

Rod Dia.	Standard & HI LOAD Gland		Metallic Rod Wiper Gland	
	Gland Wrench		Gland Wrench	Spanner Wrench
5/8	0695800000		0695900000	0116760000
1	0695810000		0695910000	0116760000
1-3/8	0695820000		0695920000	0117030000
1-3/4	0695830000		0695930000	0116770000

Bore Size	Rod Dia.	Rod No.	Standard Rod Gland Cartridge Kit Includes 1 Each Of Symbol 14, 40, 41 & 45		Hi Load Rod Gland Cartridge Kit Includes 1 Each Of Symbol 14, 40, 41 & 45		Metallic Rod Wiper Gland Cartridge Kit Includes 1 Each Of Symbol 14, 40, 41 & 45		Gland To Head Torque Units	
			Nitrile & Pur Seals Kit Number	Fluorocarbon Seals Kit Number	Nitrile & Pur Seals Kit Number	Fluorocarbon Seals Kit Number	Nitrile & Pur Seals Kit Number	Fluorocarbon Seals Kit Number	USA Ft-Lbs	Metric N-M
1-1/2	5/8	1	RG04ML0061	RG04ML0065	RG04MLH061	RG04MLH065	RG04MLM061	RG04MLM065	40 - 45	54 - 61
	1	2	RG04ML0101	RG04ML0105	RG04MLH101	RG04MLH105	RG04MLM101	RG04MLM105	45 - 50	61 - 68
2	5/8	1	RG04ML0061	RG04ML0065	RG04MLH061	RG04MLH065	RG04MLM061	RG04MLM065	40 - 45	54 - 61
	1	3	RG04ML0101	RG04ML0105	RG04MLH101	RG04MLH105	RG04MLM101	RG04MLM105	45 - 50	61 - 68
2-1/2	5/8	1	RG04ML0061	RG04ML0065	RG04MLH061	RG04MLH065	RG04MLM061	RG04MLM065	40 - 45	54 - 61
	1	3	RG04ML0101	RG04ML0105	RG04MLH101	RG04MLH105	RG04MLM101	RG04MLM105	45 - 50	61 - 68
3-1/4	1	1	RG04ML0101	RG04ML0105	RG04MLH101	RG04MLH105	RG04MLM101	RG04MLM105	45 - 50	61 - 68
	1-3/8	3	RG04ML0131	RG04ML0135	RG04MLH131	RG04MLH135	RG04MLM131	RG04MLM135	75 - 80	102 - 108
4	1	1	RG04ML0101	RG04ML0105	RG04MLH101	RG04MLH105	RG04MLM101	RG04MLM105	45 - 50	61 - 68
	1-3/8	3	RG04ML0131	RG04ML0135	RG04MLH131	RG04MLH135	RG04MLM131	RG04MLM135	75 - 80	102 - 108
5	1	1	RG04ML0101	RG04ML0105	RG04MLH101	RG04MLH105	RG04MLM101	RG04MLM105	45 - 50	61 - 68
	1-3/8	3	RG04ML0131	RG04ML0135	RG04MLH131	RG04MLH135	RG04MLM131	RG04MLM135	75 - 80	102 - 108
6	1-3/8	1	RG04ML0131	RG04ML0135	RG04MLH131	RG04MLH135	RG04MLM131	RG04MLM135	75 - 80	102 - 108
	1-3/4	3	RG04ML0171	RG04ML0175	RG04MLH171	RG04MLH175	RG04MLM171	RG04MLM175	90 - 95	122 - 129
8	1-3/8	1	RG04ML0131	RG04ML0135	RG04MLH131	RG04MLH135	RG04MLM131	RG04MLM135	75 - 80	102 - 108
	1-3/4	3	RG04ML0171	RG04ML0175	RG04MLH171	RG04MLH175	RG04MLM171	RG04MLM175	90 - 95	122 - 129



For inventory, lead times, and kit lookup, visit [www.pdnplu.com](http://www.pdnplu.com)

4ML Piston Seal Kits (Piston and cylinder body seals)

Hydraulic service

Temperatures:

- Nitrile -10°F to 165°F (-23°C to 74°C)
- Fluorocarbon -10°F to 250°F (-23°C to 121°C)

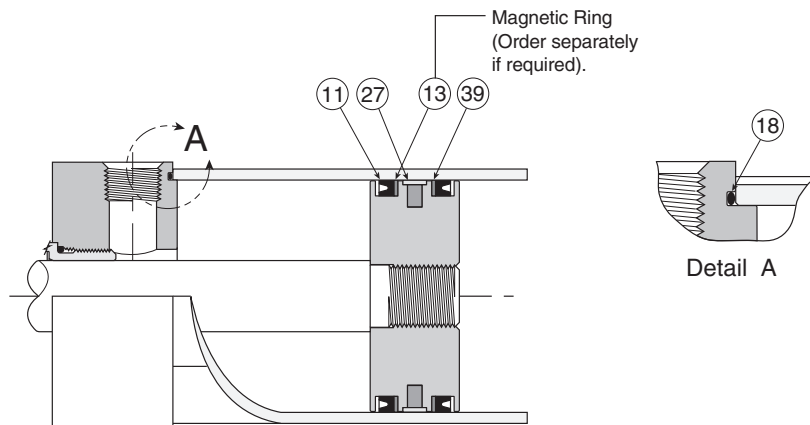

Servicing the piston seals – see next page

**Warning** – The piston rod (or fastener) to piston threaded connection is secured with an anaerobic adhesive that is temperature sensitive. Cylinders specified with all fluorocarbon seals are assembled with an anaerobic adhesive having a maximum operating temperature rating of 250°F (121°C). Cylinders specified with other seal compounds are assembled with an anaerobic adhesive having a maximum operating temperature rating of 165°F (74°C). These temperature limitations are necessary to prevent possible loosening of the threaded connections. Cylinders originally manufactured with Class 1 seals (Nitrile) that will be exposed to ambient temperatures above 165°F (74°C) must be modified for higher temperature service. Contact pdnapps@parker.com immediately and arrange for the piston to rod connection to be properly re-assembled to withstand the higher temperature service and other cylinder changes.

Every piston seal kit (PK) contains (2) of symbols 11, 18 and 39, and (1) of symbol 27.

Symbol	Description
11	Piston seal (lipseal)
18	O-ring - cylinder body to head & cap
27	Wear band
39	Piston seal backup washer

Bore Size	PK - Piston Seal Kit, Standard Lipseals Includes 2 Each Of Symbol 11, 39 & 18 Wear Band (#27) For Aluminum Piston Included		Magnetic Ring Symbol 13 Only With Nitrile Seals	Endcap Fastener Or Tie Rod Torque Units	
	Nitrile Seals Kit Number	Fluorocarbon Seals Kit Number	Part Number	USA inch-lbs	Metric N-m
1-1/2	PK1504ML01	PK1504ML05	0865130151	32 - 36	3.6 - 4.1
2	PK2004ML01	PK2004ML05	0865130200	72 - 82	8 - 9
2-1/2	PK2504ML01	PK2504ML05	0865130250	72 - 82	8 - 9
3-1/4	PK3254ML01	PK3254ML05	0865130325	216 - 228	24 - 25.3
4	PK4004ML01	PK4004ML05	0865130400	216 - 228	24 - 25.3
5	PK5004ML01	PK5004ML05	0865130500	360 - 372	41 - 42
6	PK6004ML01	PK6004ML05	0865130600	420 - 432	48 - 49
8	PK8004ML01	PK8004ML05	0865130800	960 - 972	109 - 115

<b>B</b>
Tie Rod Pneumatic Cylinders
4MA Series
4MAJ Series
ACVB Option
LPSO Option
P1D Series
P1F Series
2MNR Series



For inventory, lead times, and kit lookup, visit [www.pdnplu.com](http://www.pdnplu.com)

**Servicing the Piston Seals**

Disassemble the cylinder completely, remove the old seals and clean all the parts. The cylinder bore and piston should then be examined for evidence of scoring. (The light scratch marks usually present on both cylinder bore and piston will generally have no detrimental effects on the performance of the cylinder.)

Apply clean light oil to O.D. of piston and all grooves. Install one piston Lipseal (sym. # 11) & one Back-Up Washer (sym. #39) in the groove nearest the rod. The two “lips” of the Lipseal (sym. #11) should face toward the rod end of the piston and the Back-Up Washer (sym. #39) should be installed in the same piston groove as shown. If required, install the magnetic ring (sym. # 13) in the bottom of the middle groove. (See detail “1” below) Next, install the wear strip (sym. # 27) in the top of the middle groove – (See detail “2” below).

Coat the inside of the cylinder body with clean light oil and insert the piston – cap end first – into the cylinder body as shown in detail “3” below.

Next, turn the cylinder body on its side and push the piston and rod assembly through the barrel just far enough to expose the piston groove for the second Lipseal. (See detail “4” below.) Be careful not to move the piston too far so as to expose the wear strip (sym. # 27). If the piston should move too far, push the piston and rod assembly completely through the cylinder body and again start the piston from the original end. Now install the second Lipseal (sym. # 11) & Back-Up Washer (sym. #39) in the exposed groove with the two “lips” of the Lipseal (sym. #11) facing away from the rod and the Back-Up Washer (sym. #39) positioned as shown. Then pull the piston into the cylinder body.

The piston and rod are securely locked together with anaerobic adhesive. This threaded connection should only be disassembled or reassembled by factory trained personnel.

**NOTE:** An extreme pressure lubricant (such as molybdenum disulphate) should be used on the tie rod threads and bearing faces to reduce friction and tie rod twist.

Assemble both cap and head, complete with cylinder body O-Rings (sym. # 18), to each end of the cylinder body. Install end cap fasteners and tighten to appropriate torque, using opposite corner to corner torquing sequence. After screws are torqued, firmly torque the rod gland against the head.

In case of a “DD” – center trunnion – mounted cylinder, care must be taken to prevent binding the cylinder body when repositioning the trunnion collar. The proper method of assembling this type of cylinder is as follows:

After all the piston seals have been installed on the piston and the piston is in the cylinder body, fit the cap with its O-ring (sym. # 18) in position onto the cylinder body. Then “stud” into the trunnion collar the four tie rods that connect the cap to the trunnion collar. Hand tighten the four tie rod nuts at the cap. Distances from the inner face of the cap to the finished face of the trunnion collar should be made equal at all four tie rods when all four tie rod nuts are in contact with the cap.

When the assembly is ready for final torquing, it may be necessary to adjust the tie rods at the cap when torquing the tie rods at the head in order to position the trunnion collar in its final position.

As a check, to be certain the trunnion mount will not interfere with cylinder operation, move the piston and rod assembly by hand to determine whether there is any tendency for the piston to bind at the spot where the trunnion collar is located. If any binding is noticeable, readjust the tie rods.

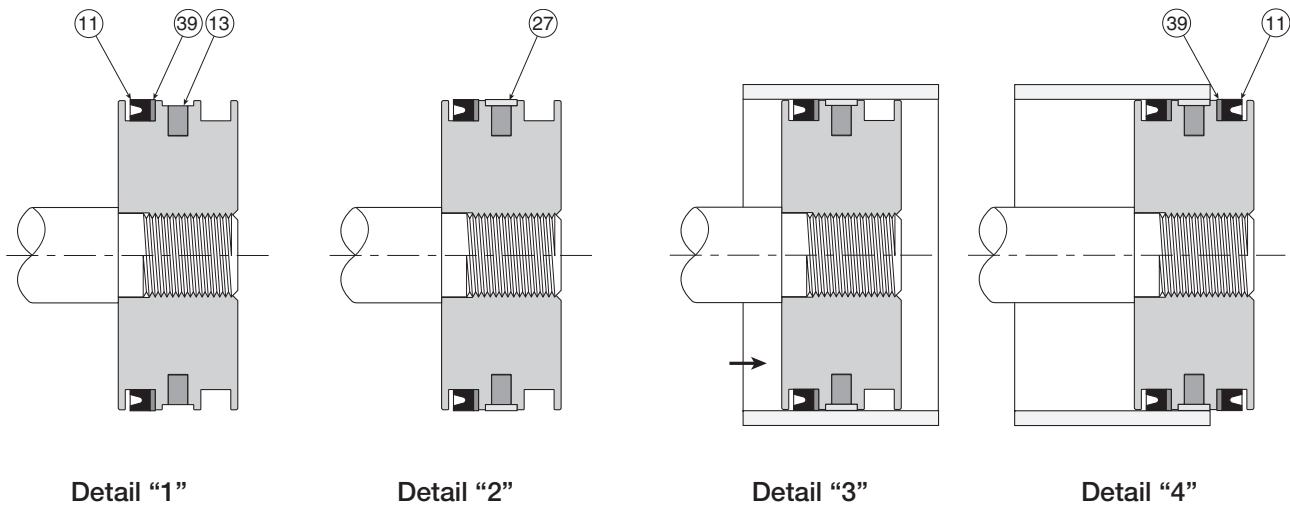

B Tie Rod Pneumatic Cylinders	4MA Series
	4MAJ Series
ACVB Option	
LPSO Option	
P1D Series	
P1F Series	
2MNR Series	

**Cylinder Kits (All parts to service entire cylinder)**

**Hydraulic service**

Temperatures:

- Nitrile/Polyurethane (PUR) -10°F to 165°F (-23°C to 74°C)
- Fluorocarbon -10°F to 250°F (-23°C to 121°C)

**Servicing the complete cylinder**

This kit offers all parts to service an entire 4ML cylinder with the standard rod gland and standard piston lipseals. Kits are available with Nitrile/Polyurethane or Fluorocarbon seals.

This kit is a combination of the Standard Gland Kit and Standard Piston Seal Kit. Please refer to the pages or bulletins of these individual kits for service instructions.



Bore Size	Rod Dia.	Rod No.	SK - Complete Cylinder Kit Includes 1 Each Of Standard Rod Gland Kit And Piston Seal Kit		Gland To Head Torque Units		Endcap Fastener Or Tie Rod Torque Units	
			Nitrile & Pur Seals Kit Number	Fluorocarbon Seals Kit Number	Usa Ft-Lbs	Metric Nm	USA Inch-Lbs	Metric Nm
1-1/2	5/8	1	<b>SK15104ML1</b>	<b>SK15104ML5</b>	40 - 45	54 - 61	32 - 36	3.6 - 4.1
	1	2	<b>SK15304ML1</b>	<b>SK15304ML5</b>	45 - 50	61 - 68		
2	5/8	1	<b>SK20104ML1</b>	<b>SK20104ML5</b>	40 - 45	54 - 61	72 - 82	8 - 9
	1	3	<b>SK20304ML1</b>	<b>SK20304ML5</b>	45 - 50	61 - 68		
2-1/2	5/8	1	<b>SK25104ML1</b>	<b>SK25104ML5</b>	40 - 45	54 - 61	72 - 82	8 - 9
	1	3	<b>SK25304ML1</b>	<b>SK25304ML5</b>	45 - 50	61 - 68		
3-1/4	1	1	<b>SK32104ML1</b>	<b>SK32104ML5</b>	45 - 50	61 - 68	216 - 228	24 - 25.3
	1-3/8	3	<b>SK32304ML1</b>	<b>SK32304ML5</b>	75 - 80	102 - 108		
4	1	1	<b>SK40104ML1</b>	<b>SK40104ML5</b>	45 - 50	61 - 68	216 - 228	24 - 25.3
	1-3/8	3	<b>SK40304ML1</b>	<b>SK40304ML5</b>	75 - 80	102 - 108		
5	1	1	<b>SK50104ML1</b>	<b>SK50104ML5</b>	45 - 50	61 - 68	360 - 372	41 - 42
	1-3/8	3	<b>SK50304ML1</b>	<b>SK50304ML5</b>	75 - 80	102 - 108		
6	1-3/8	1	<b>SK60104ML1</b>	<b>SK60104ML5</b>	75 - 80	102 - 108	420 - 432	48 - 49
	1-3/4	3	<b>SK60304ML1</b>	<b>SK60304ML5</b>	90 - 95	122 - 129		
8	1-3/8	1	<b>SK80104ML1</b>	<b>SK80104ML5</b>	75 - 80	102 - 108	960 - 972	109 - 115
	1-3/4	3	<b>SK80304ML1</b>	<b>SK80304ML5</b>	90 - 95	122 - 129		

<b>B</b>
Tie Rod Pneumatic Cylinders
4MA Series
4MAJ Series
ACVB Option
LPSO Option
P1D Series
P1F Series
2MNR Series



For inventory, lead times, and kit lookup, visit [www.pdnplu.com](http://www.pdnplu.com)

**Rod Lock Removal and Re-assembly**

**1-1/2" to 5" Bores**

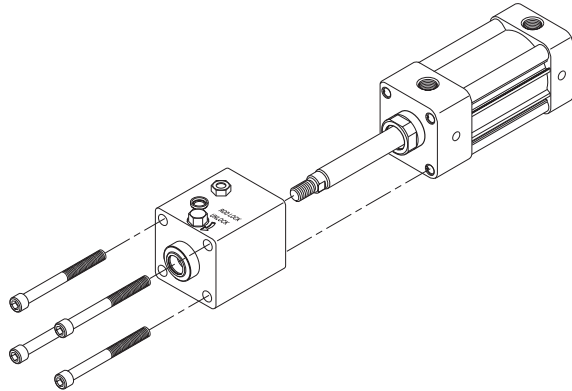

**6" to 8" Bores and  
all Style DD Mounts (NFPA MT4)**

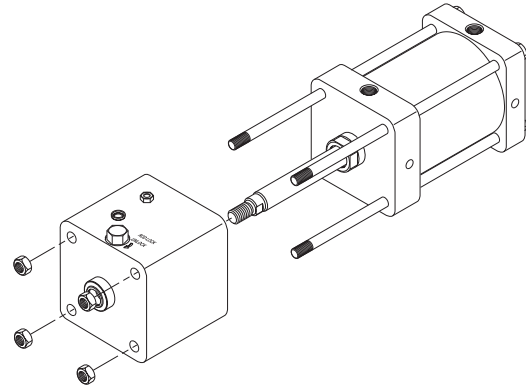

To **remove** the rod lock from the 4MAJ cylinder in order to service the base 4MAJ cylinder, please perform the following steps:

1. Remove the 4MAJ cylinder from the application to a serviceable area.
2. Using a corner-to-corner sequence, loosen the four SHCS fasteners (1-1/2" to 5" bores) or tie rod nuts (6" to 8" bores and all Style DD mounts (NFPA MT4) at the rod lock face and remove them from the rod lock. Please note that the tie rod nuts for 6" to 8" bores and all Style DD mounts are also used to assemble the base cylinder.
3. Apply a minimum of 60 PSI air pressure to the rod lock port, or apply the appropriate amount of torque to the manual override shaft, in order to release the rod lock from the piston rod.
4. Carefully slide the rod lock off the piston rod and away from the base cylinder. The rod lock is piloted and sealed to the gland OD, so some force may be required.
5. Particularly at larger bores, the rod lock can be heavy. Please remove the rod lock from the piston rod and follow all necessary safety precautions.

**SHCS Fastener Torque or Tie Rod torque**

Bore Size	Inch-lbs	Nm
1-1/2	32-36	3.6-4.1
2	72-82	8-9
2-1/2	72-82	8-9
3-1/4	216-228	24-25.3
4	216-228	24-25.3
5	360-372	41-42
6	420-432	48-49
8	960-972	109-115

To **re-assemble** the rod lock to the base 4MAJ cylinder, please perform the following steps:

1. Remove all dirt and debris from the mating features of the rod lock, base cylinder, fasteners (or nuts) and threads.
2. Apply a minimum of 60 PSI air pressure to the rod lock port, or apply the appropriate amount of torque to the manual override shaft, in order to open the rod lock.
3. Carefully slide the rod lock onto the piston rod and toward the base cylinder. The rod lock is piloted and sealed to the gland OD, so some force may be required. Press the rod lock to the head face as close as possible, avoiding damage to the rod lock o-ring that seals the gland OD.
4. Using a corner-to-corner sequence, install and tighten, to approximately 75% of final torque specifications, the SHCS fasteners (1-1/2" to 5" bores) or tie rod nuts (6" to 8" bores and all Style DD mounts (NFPA MT4)) at the rod lock face. See torque specification table below.
5. Using a calibrated torque wrench, tighten the fasteners or nuts to the final torque specification using the same corner-to-corner sequence.
6. Remove the air pressure from the rod lock port or remove the torque from the manual override shaft to return the rod lock to the locked state.

**The rod lock units are not field-repairable and must be returned to the Pneumatic Division for any repairs. Please contact pdnapps@parker.com for any assistance.**

**B**  
Tie Rod Pneumatic Cylinders  
4MAJ Series  
4MAJ Series  
ACVB Option  
LPSO Option  
P1D Series  
P1F Series  
2MNR Series



For inventory, lead times, and kit lookup, visit [www.pdnplu.com](http://www.pdnplu.com)



**P1D Series – ISO Pneumatic Cylinders**



**P1D Removable Gland Version**

P1D Removable Gland Version cylinders are available in 32-200mm bores and utilize bar stock endcaps and a removable high-strength bronze bearing for traditional and custom applications. The bronze bearing assembly is externally removable for quick and easy maintenance. No other ISO cylinder manufacturer in the world produces a Removable Gland Version and meets these demands. This version covers all applications which require performance and customization at all bore sizes.

**Removable Gland**

An extra-long inboard bearing surface ensures lubrication from within the cylinder. Outboard of the bearing are two leak-proof seals. The rod wiper seal wipes away any dirt on the rod. This means less wear on bearing surfaces and internal parts. The result is positive, no-leak sealing, regardless of conditions. And with the famous Parker removable style gland, you can replace the rod seals and/or bearings when necessary without disassembling the rest of the cylinder and without the need of any special wrenches.

**Aluminum Piston Option**

For high temperature applications, an aluminum piston is available with fluorocarbon seals. The piston is threaded onto the piston rod and secured in place with anaerobic adhesive which is temperature sensitive. For applications above 121°C (250°F) specify a pinned piston to rod connection. The polyurethane seals that are standard on the nylon piston are also an available option with the aluminum piston. The magnet that is cleverly hidden underneath the wear-band is also a standard feature on the aluminum piston. The durable wear-band prevents any metal-to-metal contact between the piston and the cylinder body wall increasing the overall life of the cylinder.

**Machined End Caps with Captive Cushion Screw Adjustment**

The end caps are made of precision lightweight aluminum. This allows for maximum flexibility and quick manufacturing for any customization that is required. The end caps also feature a captive cushion needle valve adjustment screw for optimized cushioning that is inherent throughout the P1D family of ISO cylinders.

**P1D Series Rod Lock Cylinder**

The P1D Series Rod Lock Cylinder incorporates a powerful piston rod locking device, which clamps the piston rod and locks it in position. The locking device is a spring lock with an air pressure release and is integrated into the front (head) cover of the cylinder.

In the absence of air signal pressure, full holding force is applied to the piston rod. When air is present at 4 bar (58 psi), the locking device is released.

The P1D Series Rod Lock Cylinder is available for cylinder bores 32-125mm. The design provides several valuable characteristics, such as:

- A holding force corresponding to a pressure of 7 bar (102 psi)
- A clean design, with the front (head) end cover and locking device built into a common block for compact installation
- Easy to clean, well-sealed construction
- Exhaust air from the locking device can be piped away when there are high demands for a contaminant free environment



**P1D Series Rod Lock Cylinder with Manual Override**

The P1D Series Rod Lock Cylinder with Manual Override is available for rod lock release during non-production activities. It incorporates the same features as the standard rod lock cylinder.



**B**

Tie Rod Pneumatic Cylinders

4MA Series

4MAJ Series

ACVB Option

LPSO Option

P1D Series

P1F Series

2MNR Series



For inventory, lead times, and kit lookup, visit [www.pdnplu.com](http://www.pdnplu.com)

**Features**

**P1D Tie-Rod Version**

The P1D Tie-Rod Version cylinders are based on the same high level technology as the Removable Gland Version. This cylinder is the perfect choice wherever a true tie-rod cylinder is needed.

**International standards**

The P1D Tie-Rod Version complies with ISO 6431, ISO/DIS 15552, VDMA 24562 and AFNOR installation dimension standards, for customer reassurance world-wide.

**“Drop-in” sensor**

The P1D Tie-Rod Version utilizes the same drop-in Global Sensors as the other versions. An ingenious multi-jointed adapter clamps the sensors to the tie rod in any chosen position along the stroke.

**Large Bore Sizes**

The P1D Tie-Rod Version is available in 160 and 200mm bore sizes.



32-125mm bores

**Guided Cylinders**

For guided versions of the P1D, see the P5E Series and HB Series.



P5E Series

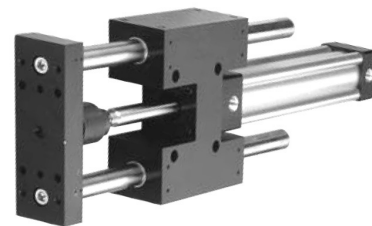

HB Series

<b>B</b>	Tie Rod Pneumatic Cylinders
	4MA Series
	4MAJ Series
	ACVB Option
	LPS0 Option
	P1D Series
	P1F Series
	2MNR Series



For inventory, lead times, and kit lookup, visit [www.pdnplu.com](http://www.pdnplu.com)



**Features**

The innovative P1D is a long lasting ISO/VDMA cylinder. The cylinders are double acting, with a new design of air cushioning.

The P1D complies with the current ISO 6431, ISO 15552, VDMA 24562 and AFNOR installation dimension standards

- Available in 32 to 200mm bores
- PUR seals for long service life
- Drop-in sensors
- Corrosion resistant design
- Magnetic piston as standard
- Lubricated with food grade grease



**Operating information**

Operating pressure:	145 PSIG (10 bar) maximum
Temperature range:	Standard: -4°F to 176°F (-20°C to 80°C) High temperature: 14°F to 250°F (-10°C to 121°C)
Filtration requirements:	40 micron, dry filtered air

**Sensors**

See section L for sensors.



**B**

Tie Rod Pneumatic Cylinders

4MA Series

4MAJ Series

ACVB Option

LPSO Option

P1D Series

P1F Series

2MNR Series

**Ordering information**

**B**  
Tie Rod Pneumatic  
Cylinders  
4MA Series  
4MAJ Series  
ACVB Option  
LPSO Option  
P1D Series  
P1F Series  
2MNR Series

**P1D - G 032 M C - 0500 N N N N N**

Piston Style		
Cushions	Piston material	
	Composite <sup>1</sup>	Aluminum
None	M	Y
Cush B/E	- <sup>3</sup>	4
Cush head	J	5
Cush cap	K	6

Bore Size	
032	32mm
040	40mm
050	50mm
063	63mm
080	80mm
100	100mm
125	125mm
160	160mm <sup>8</sup>
200	200mm <sup>8</sup>

Stroke <sup>14</sup>
Specify whole mm using 4 digits, i.e. 0500

Rod End	
N	Metric Male
6	Metric Female
3	Special*

\* Please provide desired dimensions for KK, AM and WH or W. If otherwise, please provide dimensioned sketch.

Cylinder Ports Front & Rear	
-	BSPP Ports (G Threads)**
E	NPTF Ports*

\*\* ISO 1179-1 with ISO 228-1 threads.

Sensors <sup>17</sup>	
P1D Prepared For Sensors	N

Version				
	Cylinder Body	Rod Lock		
		None	Fitted w/ Standard Rod Lock	Fitted w/ Manual Override Rod Lock
Machined End Caps Rod Lock Not Available With Removable Gland. <sup>5</sup>	Profile	G	R <sup>4</sup>	J
Special <sup>6</sup>	Tie Rod <sup>13</sup>	E	7 <sup>4</sup>	Consult Factory
	Any Special		/	

Rod Mountings	
Swivel Rod Eye	S
Swivel Rod Eye SS	T
Swivel Rod Eye With Clevis Bracket GA	V
Swivel Rod Eye Ss With Clevis Bracket GA	W
Clevis	C
Clevis SS	D
Flexco Coupling	F
One Additional Piston Rod Nut	X
Stainless Steel Piston Rod Nut	Y
Acid-Resistant Nut	Z
None (piston rod nut only)	N

	Mounting style	
	Standard	Rotated 90°
Flange MF1 at Head (front) end	1	3
Flange MF2 at Cap (rear) End	B	4
Flanges MF1 and MF2 at Both Ends	2	K
Foot Brackets MS1	F	R
Clevis Bracket GA Aluminum	C	U
Rear Eye MP4 Aluminum	E	V
Rear Swivel Eye MP6 Aluminum	S	W
Clevis Bracket MP2 Aluminum	T	Y
Rear Eye + clevis (MP4 + MP2) Aluminum	L	Z
Clevis Bracket MP2 + Pivot Hinge Aluminum	X	5
Clevis Bracket GA Aluminum + Steel Swivel Hinge	Q	0
Rear Swivel Eye + Clevis Bracket GA Aluminum	M	A
Intermediate Trunnion MT4 (requires XV dimension)	G	7
Trunnion Flange at Head (front) End <sup>4</sup>	H	P
Trunnion Flange at Cap (rear) End <sup>4</sup>	J	8
None (MX0)	N	9

Function				
Fastener Type	Rod Wiper Style	Double Acting	Double Rod	Tandem <sup>13</sup>
Standard End Cover Screws	Std Scraper	M	F	C
	Metal Scraper	Q	R	J
Stainless Steel End Cover Screws <sup>9</sup>	Std Scraper	A	G	N/A
	Metal Scraper	S	T	N/A

Piston Rod & Seal Material		
Piston Rod Material	Seal Material	
	Standard	Fluorocarbon <sup>10</sup>
Chrome Plated Carbon Steel	C	G
Chrome Plated Stainless Steel	R	D
Acid-Resistant Stainless Steel	M	N

**Notes:**

- 1 Not available for 160-200mm bores.
- 3 Must be placed in model code.
- 4 Not available for 160-200mm bores or with fluorocarbon seals.
- 5 When Removable Gland Version is fitted with rod lock, gland cannot be replaced without disassembling cylinder.
- 6 If special cylinder is ordered (other than rod end), End Cap Style, Cylinder Body Profile and Rod Lock option must be given in addition to the special request.
- 8 Tie Rod Version E must be specified for these bores.
- 9 Applies only to end cover screws for 32-125mm bores. For stainless steel tie rods and nuts (all bore sizes), change Version to special and request stainless steel tie rods and nuts.
- 10 If used for temperature above 80°C (176°F), aluminum piston required.
- 13 Tie Rod Version is required for Tandem Function.
- 14 When specifying a stop tube, place a "/" in the version field. Then specify the version, amount of stop tube and amount of net stroke. The stroke used in the model code should be gross stroke (net stroke plus stop tube).
- 17 For sensor part numbers and specifications, please refer to Electronic Sensors section.
- 19 Consult factory for this option.

**Double Rod Cylinders**  
Double rod option is available with Mounting Styles MX0, MS1, MF1, MF2 and MT4.  
For double rod cylinders, it is assumed that the rod number and rod end are the same for both piston rods. On a double rod cylinder where the two rod ends are different, use a rod end of '3' and be sure to clearly state which rod end is to be assembled at which end.

**For ordering purposes, when special options or common modifications are requested, the factory will assign a sequential part number in place of the model number.**



For inventory, lead times, and kit lookup, visit [www.pdnplu.com](http://www.pdnplu.com)

**General Specifications**

- Bore sizes 32-200mm
- Max stroke 2800mm
- Min stroke 25mm  
(must specify Tie Rod Version for strokes <25mm)
- Rod Ends – 2 standard, specials to order
- Single rod end and double rod end styles
- Working pressure Max 10 bar (145 PSI)
- Working temperature –  
-20°C to 80°C (-4°F to 176°F) standard  
-10°C to 121°C (14°F to 250°F) high temp version
- Aluminum piston is required for service above  
80°C (176°F)
- Greased for life (non-lube), does not normally need additional  
lubrication. If air line lubrication is initiated, it must always be  
continued.
- Working medium: Dry, filtered compressed air  
to ISO 8573-1 class 3. 4. 3. or better

**P1D Rod Lock Version**

- Fluid Medium: Dry, filtered, compressed air
  - Maximum Cylinder Operating Pressure: 10 bar (145 PSI)
  - Required Pressure to Unlock<sup>1</sup>: 4 bar (58 PSI)
  - Minimum Torque Required for Manual Override Version:  
32mm Bore = 0.9 N-m / 8 in-lbs  
40mm Bore = 0.9 N-m / 8 in-lbs  
50mm Bore = 2.7 N-m / 24 in-lbs  
63mm Bore = 2.7 N-m / 24 in-lbs  
80mm Bore = 27.1 N-m / 240 in-lbs  
100mm Bore = 36.6 N-m / 324 in-lbs  
125mm Bore = 61.0 N-m / 540 in-lbs
  - Operating Temperature:  
-10°C to 75°C (14°F to 167°F)  
Min stroke 10mm
  - Maximum Cylinder Operating Speed: 5 feet per second
- <sup>1</sup> Signal pressure to port on locking device. Operation at pressures  
lower than 4 bar (58 psi) may lead to inadvertent engagement of  
the rod lock device.

**Quick Reference**

Bore size	Cylinder area, cm <sup>2</sup>	Piston rod			Cushioning length mm	Air consumption <sup>1</sup> liter	Connection thread <sup>4</sup>	Theoretical cylinder forces At 6 Bar (N) <sup>2</sup>	
		Dia. Mm	Area, Cm <sup>2</sup>	Male Thread				Extend stroke	Retract stroke
32	8.0	12	1.1	M10x1.25	17	0.105	G1/8	482	414
40	12.6	16	2.0	M12x1.25	19	0.162	G1/4	754	633
50	19.6	20	3.1	M16x1.5	20	0.253	G1/4	1178	989
63	31.2	20	3.1	M16x1.5	23	0.414	G3/8	1870	1681
80	50.3	25	4.9	M20x1.5	23	0.669	G3/8	3016	2721
100	78.5	25	4.9	M20x1.5	27	1.043	G1/2	4712	4417
125	122.7	32	8.0	M27x2	30	1.662	G1/2	7363	6880
160	201.1	40	12.6	M36x2	38	2.724	G3/4	12,064	11,310
200	314.2	40	12.6	M36x2	38	4.256	G3/4	18,850	18,096

Cylinder Bore Size	Total Mass (kg)				Total Mass (kg) Moving Components			Adder for Rod Lock
	0mm Stroke <sup>3</sup>		Supplement Per 10mm Stroke		at 0mm Stroke All Variants	Supplement Per 10mm Stroke All Variants		
	Basic	Tie-Rod	Basic	Tie-Rod				
32	0.55	0.54	0.023	0.022	0.13	0.009	0.41	
40	0.80	0.79	0.033	0.030	0.24	0.016	0.44	
50	1.20	1.20	0.048	0.048	0.42	0.025	0.61	
63	1.73	1.73	0.051	0.051	0.50	0.025	1.25	
80	2.45	2.47	0.075	0.079	0.90	0.039	2.45	
100	4.00	4.00	0.084	0.084	1.10	0.039	3.72	
125	6.87	6.73	0.138	0.129	2.34	0.063	6.07	
160	—	16.19	—	0.160	Consult Factory	Consult Factory	Consult Factory	
200	—	22.23	—	0.185	Consult Factory	Consult Factory	Consult Factory	

1 Free air consumption per 10mm stroke for a double stroke at 6 bar  
2 The values for cylinder forces are theoretical and should be reduced to suit working conditions.  
3 Total Mass for composite piston for 32-125mm bores and aluminum piston for 160-200mm bores.  
4 ISO 1179-1 with ISO 228-1 threads

**B**

Tie Rod Pneumatic Cylinders

4MA Series

4MAJ Series

ACVB Option

LPSO Option

P1D Series

P1F Series

2MNR Series



For inventory, lead times, and kit lookup, visit [www.pdnplu.com](http://www.pdnplu.com)

## Material Specifications

### Piston Rod Material Options

(or with equivalent properties):

Standard	Case-hardened, chrome plated carbon steel
Chrome plated stainless steel	17-4 PH, chrome plated stainless steel
Acid-resistant stainless steel	316 stainless steel



## Tie Rod Pneumatic Cylinders P1D Series

### Additional/Substitute Specifications

#### P1D Tie-Rod Version

Tie-rod	Blackened steel
---------	-----------------

#### P1D Removable Gland Version

End covers	Black anodized aluminum
End cover screws	Zinc plated steel 8.8 (32-125mm bores)
Cylinder Body	Clear anodized aluminum
Rod gland	PTFE filled high strength bronze
Rod seal	Buna Nitrile for sealing action
Rod wiper	Buna Nitrile for wiping action
Piston rod	Case hardened chrome-plated steel
Piston rod nut	Zinc plated steel
Piston	POM (standard) Aluminum (optional)
Piston seals	PUR
Piston bearing	POM or Molyguard wear band for aluminum piston
Magnetic ring	Plastic bound magnetic material
Piston fastener	Zinc plated steel (composite piston)
O-rings	Buna Nitrile
Cushioning seals	PUR
Cushioning screws	Stainless steel (brass for 160 and 200mm bores)

#### Design Variants for Removable Gland Version

High temperature option includes:

All seals	Fluorocarbon
Piston	Aluminum (without magnetic ring)

Low pressure hydraulic option includes:

Rod seal	Buna Nitrile
Rod wiper	NBR
Piston seals	Buna Nitrile
Piston	Aluminum (non-cushioned)

Metallic Rod Scraper includes:

Rod wiper	Dual high strength bronze wipers with nitrile or fluorocarbon energizer
-----------	---

**B**  
Tie Rod Pneumatic Cylinders

4MA Series

4MAJ Series

ACVB Option

LP50 Option

P1D Series

P1F Series

2MNR Series



**Cushioning Characteristics**

The diagram below is used for sizing of cylinders related to the cushioning capacity. The maximum cushioning capacity shown in the diagram assumes the following:

- Low load, i.e. low pressure drop across the piston
- Equilibrium speed
- Correctly adjusted cushioning screw
- 6 bar at cylinder port

The load is the sum of internal and external friction, plus any gravitational forces. At high relative load (pressure drop exceeding 1 bar), we recommend that for any given speed, the mass should be reduced by a factor of 2.5, or for a given mass, the speed should be reduced by a factor of 1.5. This is in relation to the maximum performance given in the diagram.

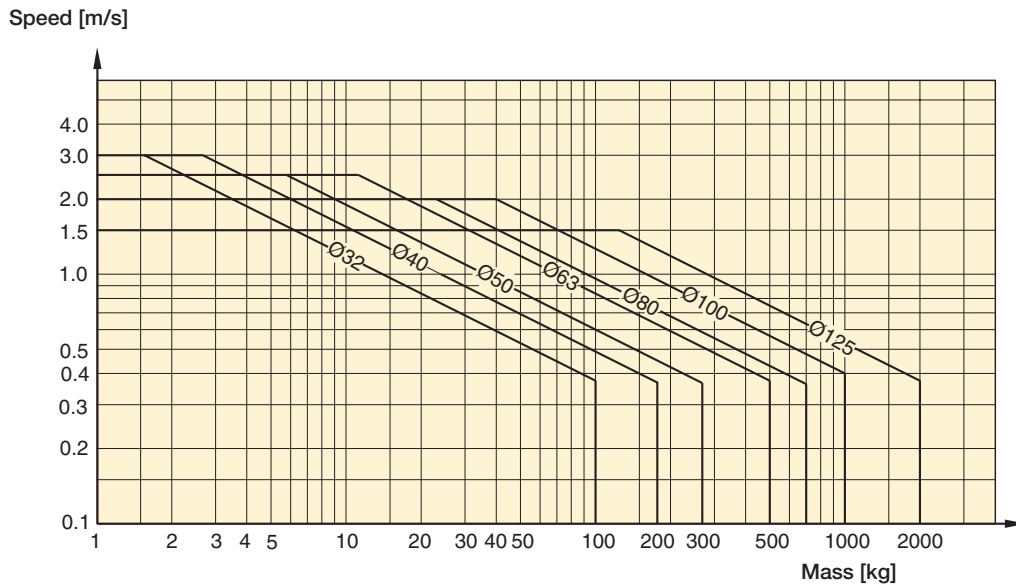

**Recommended Air Quality for Cylinders**

For best possible service life and trouble-free operation, ISO 8573-1 quality class 3.4.3 should be used. This means 5 µm filter (standard filter) dew point 3°C (37°F) for indoor operation (a lower dew point should be selected for outdoor operation) and oil concentration 1.0 mg oil/m<sup>3</sup>, which is what a standard compressor with a standard filter gives.

**ISO 8573-1 Quality Classes**

Quality Class	Pollution		Water		Oil
	Particle Size (mm)	Max. Concentration (mg/m <sup>3</sup> )	Max Pressure Dew Point (°C / °F)		Max. Concentration (mg/m <sup>3</sup> )
1	0.1	0.1	-70	-94	0.01
2	1	1	-40	-40	-0.1
3	5	5	-20	-4	1.0
4	15	8	+3	+37	5.0
5	40	10	+7	+44	25
6	-	-	+10	+50	-

**B**

Tie Rod Pneumatic Cylinders

4MA Series

4MAJ Series

ACVB Option

LPSO Option

P1D Series

P1F Series

2MNR Series



**Guide for Selecting Suitable Tubing**

The selection of the correct size of tubing is often based on experience, with no great thought to optimizing energy efficiency and cylinder velocity. This is usually acceptable, but making a rough calculation can result in worthwhile economic gains.

**The following is the basic principle:**

1. The primary line to the working valve could be oversized (this does not cause any extra air consumption and consequently does not create any extra costs in operation).
2. The tubes between the valve and the cylinder should, however, be optimized according to the principle that an insufficient bore throttles the flow and thus limits the cylinder speed, while an oversized pipe creates a dead volume which increases the air consumption and filling time.

The chart below is intended to help when selecting the correct size of tube to use between the valve and the cylinder.

**The following prerequisites apply:**

The cylinder load should be about 50% of the theoretical force (= normal load). A lower load gives a higher velocity and vice versa. The tube size is selected as a function of the cylinder bore, the desired cylinder velocity and the tube length between the valve and the cylinder.

If you want to use the capacity of the valve to its maximum, and obtain maximum speed, the tubing should be chosen so that they at least correspond with the equivalent restriction diameter (see description below), so that the tubing does not restrict the total flow. This means that a short tubing must have at least the equivalent restriction diameter. If the tubing is longer, choose it from the table below. Straight fittings should be chosen for highest flow rates. (Elbow and banjo fittings cause restriction.)

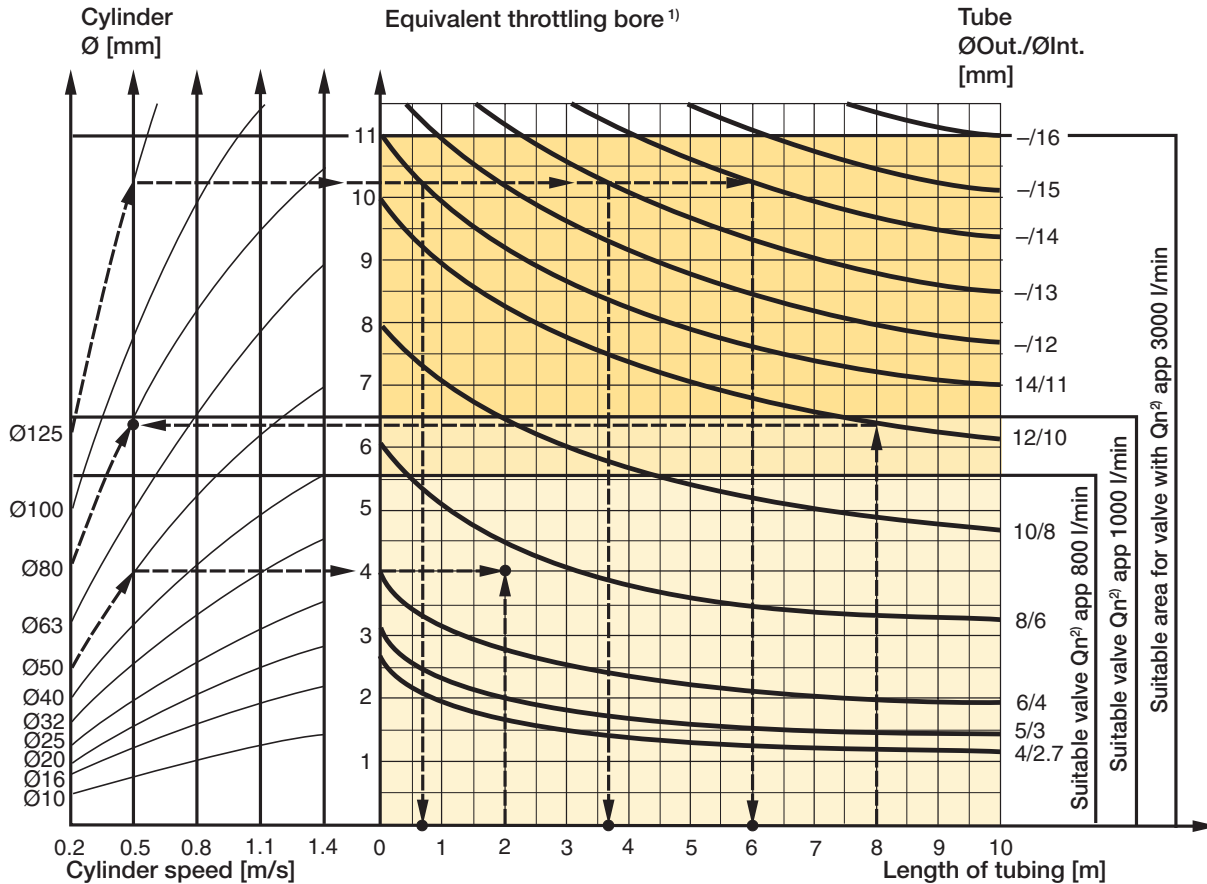

1) The "equivalent throttling bore" is a long throttle (for example a tube) or a series of throttles (for example, through a valve) converted to a short throttle which gives a corresponding flow rate. This should not be confused with the "orifice" which is sometimes specified for valves. The value for the orifice does not normally take account of the fact that the valve contains a number of throttles.

2) Qn is a measure of the valve flow capacity, with flow measured in liter per minute (l/min) at 6 bar(e) supply pressure and 1 bar pressure drop across the valve.

B	Tie Rod Pneumatic Cylinders
	Series
4MA Series	Option
4MAJ Series	Option
ACVB Series	Option
LPSO Series	Option
P1D Series	Option
P1F Series	Option
2MNR Series	Option



For inventory, lead times, and kit lookup, visit [www.pdnplu.com](http://www.pdnplu.com)

**P1D Rod Lock Version – Rod Lock Data**

**Connection**

The signal air for the locking device can be obtained directly from a main air supply, or from the air supply serving the valve that controls the cylinder itself. For controlled ON/OFF operation of the locking device, a separate quick-venting valve is used.

The piston rod should not be moving when the locking device is activated. The locking device is not intended to brake a movement in repeated sequences.

**Holding Forces\***

Bore size	Holding forces	
	(N)	(lbs)
32mm	550	123
40mm	860	193
50mm	1345	303
63mm	2140	481
80mm	3450	755
100mm	5390	1211
125mm	8425	1894

**NOTE:** All P1D Rod Lock Versions are not intended for use in water service applications, or in environments that have high humidity levels and/or splashing fluids present.

\* While cylinder is on extend at 87 PSI.

**Use as a Brake**

The chart to the right shows the maximum values for speed and braking mass if the cylinder is used as a brake. The cylinder should not be exposed to additional compressive forces as this significantly reduces the external mass that can be braked.

We recommend systems in which the cylinder does not act as a motor during braking. Heat is generated if the brake is used frequently, and this must be taken into account to ensure that the maximum temperature is not exceeded.

**Sample Pneumatic Circuit**

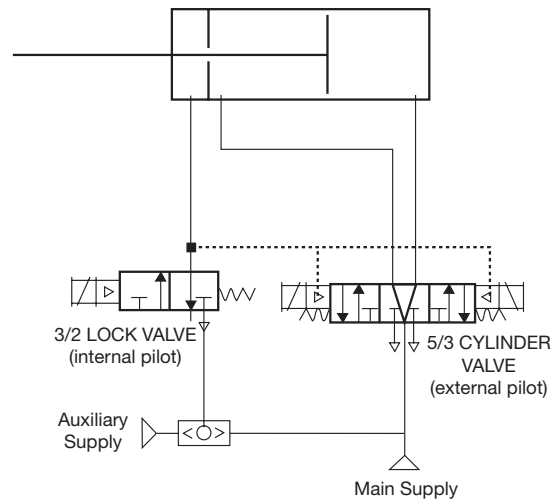

1. Lock valve must be maintained energized during cylinder motion, otherwise rod lock is engaged and cylinder valve shifts to mid position.
2. Cylinder valve must be maintained energized during extend or retract. Also keep energized at end of stroke until change of direction is desired.
3. Mid position of 5/3 Cylinder valve may be pressurized outlets if the combination of pressure load on the cylinder and inertia effects of the attached load do not exceed the holding force rating of the rod lock device, including allowance for wear.
4. Do not use cylinder lines for any logic functions — pressure levels vary too much.

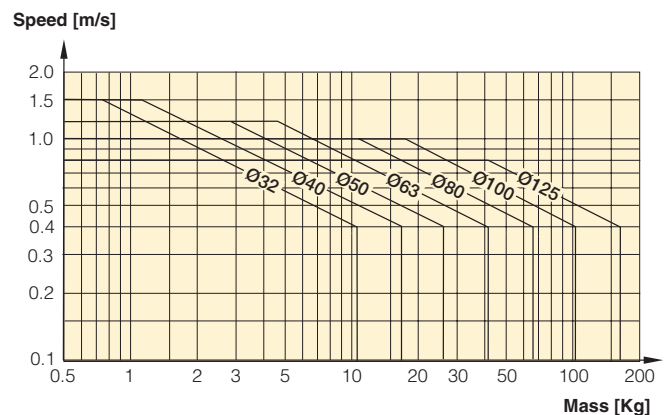

<b>B</b>	Tie Rod Pneumatic Cylinders
	4MA Series
	4MAJ Series
	ACVB Option
	LPSO Option
	P1D Series
	P1F Series
	2MNR Series



P1D Removable Gland Version

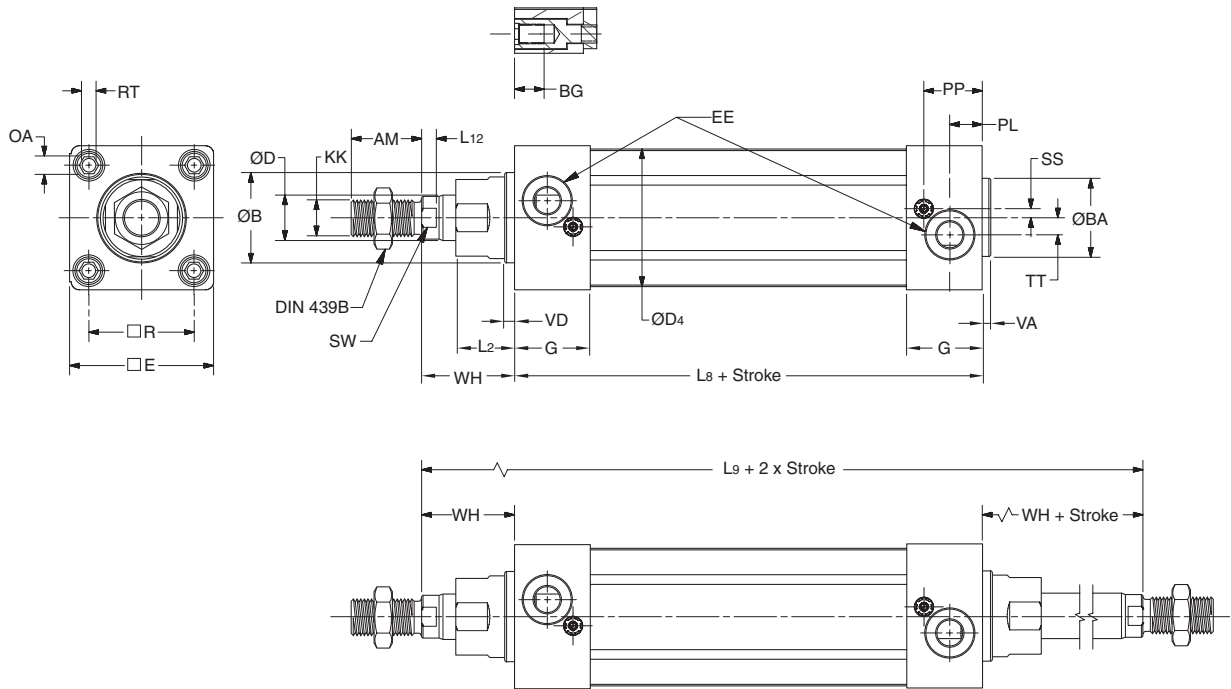

Removable Gland Version

Bore Size	AM mm	B mm	BA mm	BG mm	D mm	D4 mm	E mm	EE		G mm	KK <sup>2</sup>	L2 mm	L8 mm	L9 mm	L12 mm
								BSPP <sup>1</sup>	NPTF/BSPT						
32	22	30	30	16	12	45.0	46.5	G1/8	1/8	28.5	M10x1.25	18	94	146	6.0
40	24	35	35	16	16	52.0	52.0	G1/4	1/4	33.0	M12x1.25	20	105	165	6.5
50	32	40	40	16	20	60.7	63.5	G1/4	1/4	33.5	M16x1.5	26	106	180	6.5
63	32	45	45	16	20	71.5	76.0	G3/8	3/8	39.5	M16x1.5	26	121	195	6.5
80	40	45	45	17	25	86.7	95.5	G3/8	3/8	39.5	M20x1.5	33	128	220	10.0
100	40	55	55	17	25	106.7	114.5	G1/2	1/2	44.5	M20x1.5	33	138	240	10.0
125	54	60	60	20	32	134.0	140.0	G1/2	1/2	51.0	M27x2	41	160	290	13.0

Bore Size	OA mm	PL mm	PP mm	R mm	RT	SS mm	SW mm	TT mm	VA mm	VD mm	WH mm
32	6	13	21.8	32.5	M6	6.5	10	4.5	3.5	4.5	26
40	6	14	21.9	38.0	M6	8.0	13	5.5	3.5	4.5	30
50	8	14	25.9	46.5	M8	4.0	17	7.5	3.5	4.5	37
63	8	16	27.4	56.5	M8	6.5	17	11.0	3.5	4.5	37
80	6	16	30.5	72.0	M10	0	22	15.0	3.5	4.5	46
100	6	18	35.8	89.0	M10	0	22	20.0	3.5	4.5	51
125	8	23	40.5	110.0	M12	0	27	17.5	5.5	6.5	65

1 ISO 1179-1 with ISO 228-1 threads.

2 See rod ends and special threads, for female rod threads see page B106.

**P1D Rod Lock Version R**

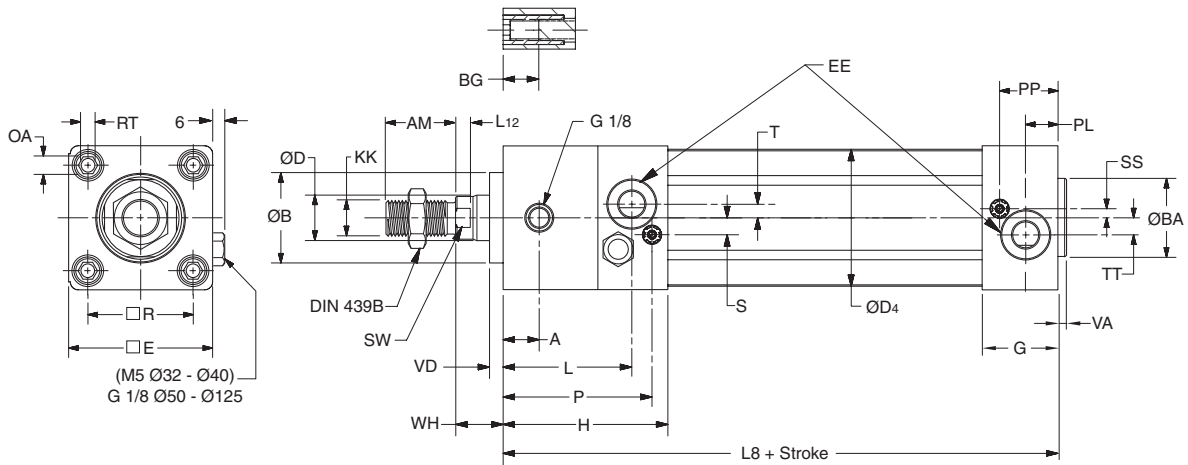

**Rod Lock (Version R)**

Bore Size	A mm	AM mm	B mm	BA mm	BG mm	D mm	D4 mm	E mm	EE <sup>1</sup>	G mm	H mm	KK <sup>2</sup>	L mm	L8 mm	L12 mm
32	16	22	30	30	16	12	45.0	46.5	G1/8	28.5	71.5	M10x1.25	56.0	137	6.0
40	16	24	35	35	16	16	52.0	52.0	G1/4	33.0	77.0	M12x1.25	56.0	149	6.5
50	18	32	40	40	16	20	60.7	63.5	G1/4	33.5	80.5	M16x1.5	62.5	153	6.5
63	26	32	45	45	16	20	71.5	76.0	G3/8	39.5	96.5	M16x1.5	74.5	178	6.5
80	35	40	45	45	17	25	86.7	95.5	G3/8	39.5	110.5	M20x1.5	87.0	199	10.0
100	50	40	55	55	17	25	106.7	114.5	G1/2	44.5	132.5	M20x1.5	106.0	226	10.0
125	60	54	60	60	20	32	134.0	140.0	G1/2	51.0	145.0	M27x2	117.0	254	13.0

  

Bore Size	OA mm	P mm	PL mm	PP mm	R mm	RT mm	S mm	SS mm	SW mm	T mm	TT mm	VA mm	VD mm	WH mm
32	6	64.8	13	21.8	32.5	M6	7	6.5	10	2.5	4.5	3.5	4.5	15
40	6	68.0	14	21.9	38.0	M6	9	8.0	13	2.0	5.5	3.5	4.5	16
50	8	73.5	14	25.9	46.5	M8	8	4.0	17	4.0	7.5	3.5	5.0	17
63	8	89.5	16	27.4	56.5	M8	8	6.5	17	2.0	11.0	3.5	5.0	17
80	6	101.5	16	30.5	72.0	M10	9	0	22	5.0	15.0	3.5	4.0	20
100	6	123.5	18	35.8	89.0	M10	12	0	22	6.0	20.0	3.5	4.0	20
125	8	136.0	23	40.5	110.0	M12	12	0	27	6.0	17.5	5.5	6.0	27

1 ISO 1179-1 with ISO 228-1 threads  
 2 See Rod Ends and Special Threads

<b>B</b>	Tie Rod Pneumatic Cylinders
	4MA Series
4MAJ Series	
ACVB Option	
LPSO Option	
P1D Series	
P1F Series	
2MNR Series	

P1D Rod Lock Version with Manual Override (Version J)

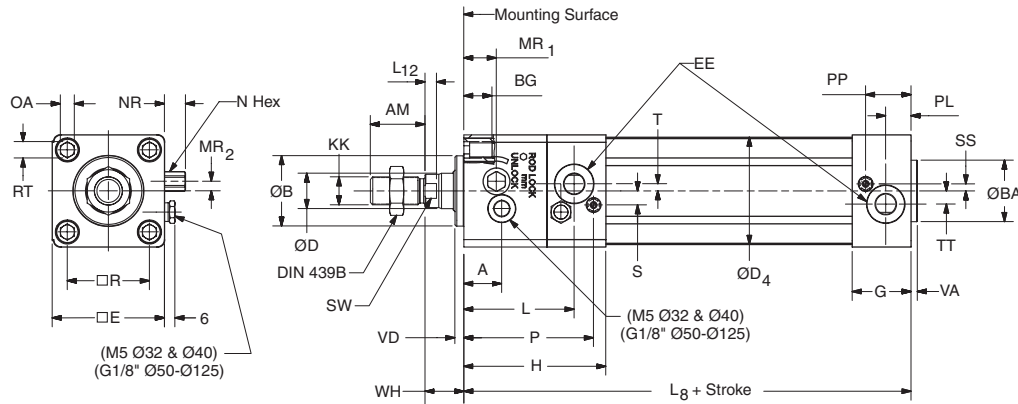

Rod Lock Version with Manual Override (Version J)

Bore Size	A mm	AM mm	B mm	BA mm	BG mm	D mm	D4 mm	E mm	EE <sup>1</sup>	G mm	H mm	KK <sup>2</sup>	L mm	L8 mm	L12 mm	MR1 mm	MR2 mm
32	27.0	22	30	30	16	12	45.0	46.5	G1/8	28.5	71.5	M10X1.25	56.0	137	6.0	16.0	3.0
40	27.0	24	35	35	16	16	52.0	52.0	G1/4	33.0	77.0	M12X1.25	56.0	149	6.5	16.0	3.0
50	21.5	32	40	40	16	20	60.7	63.5	G1/4	33.5	80.5	M16X1.5	62.5	153	6.5	18.5	5.5
63	39.0	32	45	45	16	20	71.5	76.0	G3/8	39.5	96.5	M16X1.5	74.5	178	6.5	22.0	4.0
80	48.5	40	45	45	17	25	86.7	95.5	G3/8	39.5	110.5	M20X1.5	87.0	199	10.0	15.0	19.8
100	65.0	40	55	55	17	25	106.7	114.5	G1/2	44.5	132.5	M20X1.5	106.0	226	10.0	15.0	20.8
125	71.0	54	60	60	20	32	134.0	140.0	G1/2	51.0	145.0	M27X2	117.0	254	13.0	19.0	23.0

Bore Size	N mm	NR mm	OA mm	P mm	PL mm	PP mm	R mm	RT	S mm	SS mm	SW mm	T mm	TT mm	VA mm	VD mm	WH mm
32	8	10.0	6	64.8	13	21.8	32.5	M6	7	6.5	10	2.5	4.5	3.5	4.5	15
40	8	10.0	6	68.0	14	21.9	38.0	M6	9	8.0	13	2.0	5.5	3.5	4.5	16
50	10	12.0	8	73.5	14	25.9	46.5	M8	8	4.0	17	4.0	7.5	3.5	5.0	17
63	10	12.0	8	89.5	16	27.4	56.5	M8	8	6.5	17	2.0	11.0	3.5	5.0	17
80	11	12.5	6	101.5	16	30.5	72.0	M10	9	0	22	5.0	15.0	3.5	14.0	30
100	11	12.5	6	123.5	18	35.8	89.0	M10	12	0	22	6.0	20.0	3.5	14.0	30
125	11	12.5	8	136.0	23	40.5	110.0	M12	12	0	27	6.0	17.5	5.5	16.0	37

1 ISO 1179-1 with ISO 228-1 threads  
2 See Rod Ends and Special Threads

Tolerances

Bore Size	B mm	R mm	L8 mm	BA mm	Stroke-length tolerance mm
32	d11	±0.5	±0.4	d11	+1/-0
40	d11	±0.5	±0.7	d11	+1/-0
50	d11	±0.6	±0.7	d11	+1/-0
63	d11	±0.7	±0.8	d11	+1/-0
80	d11	±0.7	±0.8	d11	+1/-0
100	d11	±0.7	±1.0	d11	+1/-0
125	d11	±1.1	±1.0	d11	+1/-0

**B**  
 Tie Rod Pneumatic Cylinders  
 Series  
 4MA  
 Series  
 4MAJ  
 Option  
 ACVB  
 Option  
 LPSO  
 Series  
 P1D  
 Series  
 P1F  
 Series  
 2MNR



For inventory, lead times, and kit lookup, visit [www.pdnplu.com](http://www.pdnplu.com)

B102

Parker Hannifin Corporation  
Pneumatic Division  
Wadsworth, Ohio  
[www.parker.com/pneumatics](http://www.parker.com/pneumatics)

**P1D Tie-Rod Version (32-125mm)**

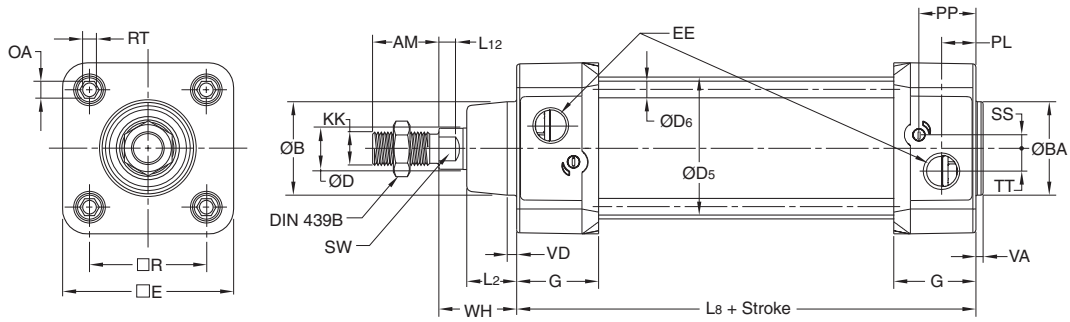

**Tie-Rod (32-125mm)**

Bore Size	AM mm	B mm	BA mm	D mm	D5 mm	D6 mm	E	EE		G mm	KK <sup>2</sup>	L2 mm	L8 mm
								BSP <sup>1</sup>	NPTF/BSPT				
32	22	30	30	12	36	5.3	50.0	G1/8	1/8	28.5	M10x1.25	16.0	94
40	24	35	35	16	45	5.3	57.4	G1/4	1/4	33.0	M12x1.25	19.0	105
50	32	40	40	20	55	7.1	69.4	G1/4	1/4	33.5	M16x1.5	24.0	106
63	32	45	45	20	68	7.1	82.4	G3/8	3/8	39.5	M16x1.5	24.0	121
80	40	45	45	25	85	8.9	99.4	G3/8	3/8	39.5	M20x1.5	30.0	128
100	40	55	55	25	105	8.9	116.0	G1/2	1/2	44.5	M20x1.5	32.4	138
125	54	60	60	32	132	10.7	139.0	G1/2	1/2	51.0	M27x2	45.0	160

Bore Size	L12 mm	OA mm	PL mm	PP mm	R mm	RT	SS mm	SW mm	TT mm	VA mm	VD mm	WH mm
32	6.0	6	13	21.8	32.5	M6	4.0	10	4.5	3.5	4.5	26
40	6.5	6	14	21.9	38.0	M6	8.0	13	5.5	3.5	4.5	30
50	8.0	8	14	25.9	46.5	M8	4.0	17	7.5	3.5	4.5	37
63	8.0	8	16	27.4	56.5	M8	6.5	17	11.0	3.5	4.5	37
80	10.0	6	16	30.5	72.0	M10	0	22	15.0	3.5	4.5	46
100	10.0	6	18	35.8	89.0	M10	0	22	20.0	3.5	4.5	51
125	13.0	8	23	40.5	110.0	M12	0	27	17.5	3.5	6.5	65

1 ISO 1179-1 with ISO 228-1 threads  
 2 See Rod Ends and Special Threads

**B**

Tie Rod Pneumatic Cylinders

4MA Series

4MAJ Series

ACVB Option

LPSO Option

P1D Series

P1F Series

2MNR Series



For inventory, lead times, and kit lookup, visit [www.pdnplu.com](http://www.pdnplu.com)

**P1D Tie-Rod Version (160-200mm)**

**B**  
 Tie Rod Pneumatic Cylinders  
 4MA Series  
 4MAJ Series  
 ACVB Option  
 LP50 Option  
 P1D Series  
 P1F Series  
 2MNR Series

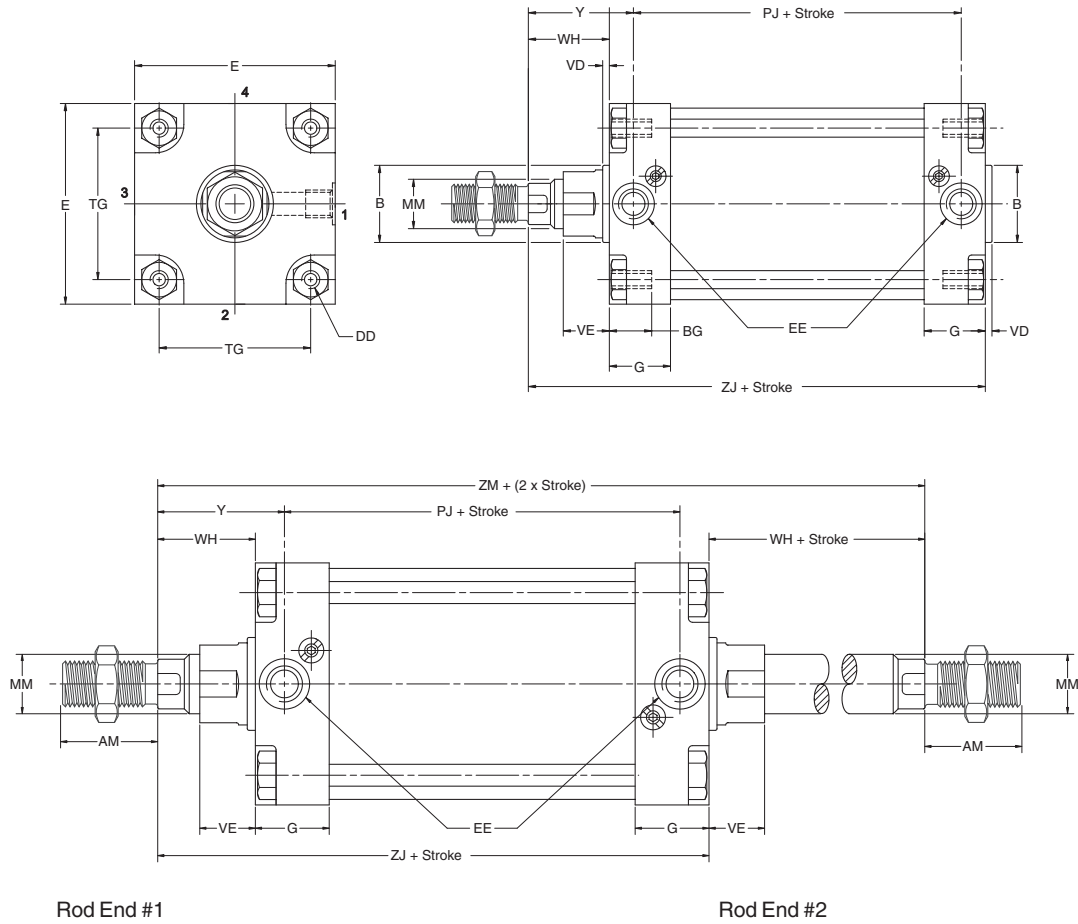

**P1D Tie-Rod Version (160-200mm)**

Bore size	AM mm	B d11 mm	BG mm	DD	E mm	EE		G mm	MM mm	TG mm	VD mm	VE mm	WH mm	Y mm	PJ1 mm	ZJ1 mm	ZM2 mm
						BSPP <sup>3</sup>	NPTF/BSPT										
160	72	65	24	M16	177	G3/4	3/4	54	40	140	6	56	80	105	130	260	340
200	72	75	24	M16	214	G3/4	3/4	54	40	175	6	56	95	120	130	275	370

<sup>1</sup> Add stroke  
<sup>2</sup> Add 2x stroke  
<sup>3</sup> ISO 1179-1 with ISO 228-1 threads

**Double Rod Cylinders**

Double rod option is available on Mounting Styles MX0, MS1, MF1, MF2 and MT4.

For double rod cylinders, it is assumed that the rod number and rod end are the same for both piston rods. On a double rod cylinder where the two rod ends are different, use a rod end of '3' and be sure to clearly state which rod end is to be assembled at which end.



For inventory, lead times, and kit lookup, visit [www.pdnplu.com](http://www.pdnplu.com)

**All Mountings Except MF1**

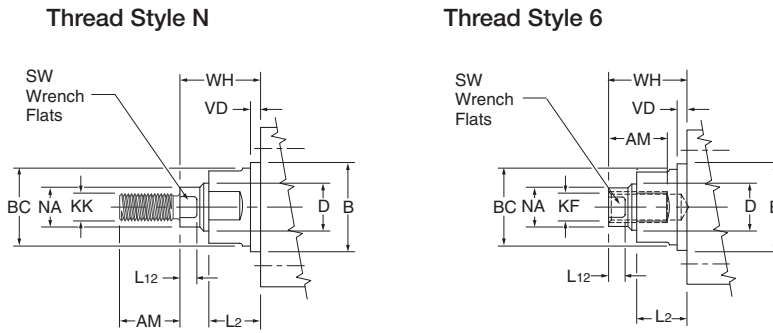

**Thread Style 3 -  
“Special Thread”**

Special thread, extension, rod eye, blank, etc are also available. To order, specify “Style 3” and provide desired dimensions for KF or KK, AM and WH. If otherwise special, furnish dimensioned sketch.

Bore Size	D	KK	KF	AM	B d11	BC	SW Across Flats	L12	NA	VD	L2	WH*
32	12	M10x1.25	M8x1	22	30	27	10	6	11	4.5	18	26
40	16	M12x1.25	M10x1.25	24	35	32	13	6.5	15	4.5	20	30
50	20	M16x1.5	M14x1.5	32	40	36	17	6.5	19	4.5	26	37
63	20	M16x1.5	M14x1.5	32	45	36	17	6.5	19	4.5	26	37
80	25	M20x1.5	M18x1.5	40	45	41	22	10	24	4.5	33	46
100	25	M20x1.5	M18x1.5	40	55	41	22	10	24	4.5	33	51
125	32	M27x2	M24x2	54	60	50	27	13	31	6.5	41	65
160	40	M36x2	M30x2	72	65	60	36	16	39	6	56	80
200	40	M36x2	M30x2	72	75	60	36	16	39	6	56	95

\*NOTE: Dimensions do not apply to Rod Lock Versions.

**With MF1 Mounting**

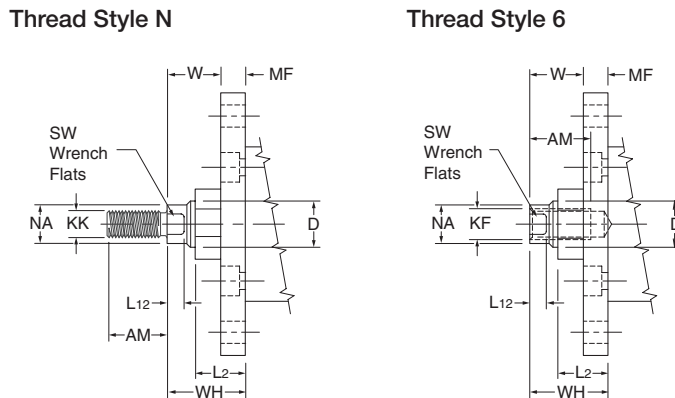

**“Special Thread”  
Style 3**

Special thread, extension, rod eye, blank, etc are also available. To order, specify “Style 3” and provide desired dimensions for KF or KK, AM and WH. If otherwise special, furnish dimensioned sketch.

Bore Size	D	KK	KF	AM	SW Across Flats	L12	MF	NA	L2	W†	WH†
32	12	M10x1.25	M8x1	22	10	6	10	11	18	16	26
40	16	M12x1.25	M10x1.25	24	13	6.5	10	15	20	20	30
50	20	M16x1.5	M14x1.5	32	17	6.5	12	19	26	25	37
63	20	M16x1.5	M14x1.5	32	17	6.5	12	19	26	25	37
80	25	M20x1.5	M18x1.5	40	22	10	16	24	33	30	46
100	25	M20x1.5	M18x1.5	40	22	10	16	24	33	35	51
125	32	M27x2	M24x2	54	27	13	20	31	41	45	65
160	40	M36x2	M30x2	72	36	16	20	39	56	60	80
200	40	M36x2	M30x2	72	36	16	25	39	56	70	95

\*NOTE: Dimensions do not apply to Rod Lock Versions.

**B**  
Tie Rod Pneumatic Cylinders  
4MA Series  
4MAJ Series  
ACVB Option  
LPSO Option  
P1D Series  
P1F Series  
2MNR Series



For inventory, lead times, and kit lookup, visit [www.pdnplu.com](http://www.pdnplu.com)

Duplex & Tandem Cylinders

3 and 4-Position Duplex Cylinders

This type of cylinder function can consist of two cylinders installed back to back. Two cylinders with the same stroke result in a 3-position cylinder with a symmetrical center position, whereas two different strokes result in a 4-position cylinder where the two central positions can be calculated from the different stroke lengths.

A 3-position duplex cylinder can also be obtained by mounting two cylinders of different strokes, in series, but not connecting the piston rods together.

These 3 and 4-position cylinders can be ordered in two ways as follows.

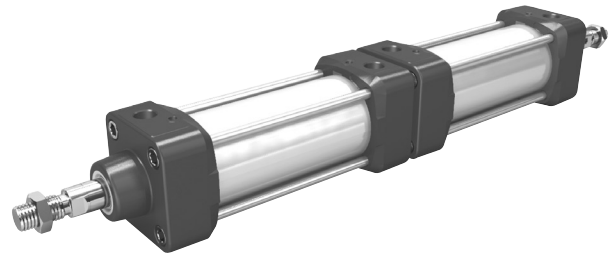

Factory-fitted P1D Duplex Cylinders

P1D tie-rod version duplex cylinders are completed at the factory and are joined together as one unit by special tie-rod. This version needs to be ordered as a special (/). Please consult factory for assistance.

Customer-Installed Mounting Kit

There is an installation mounting kit available for cylinder bores 32-100mm which makes it possible to join any two P1D cylinders, of the same bore, together at any time to make a 3 or 4-position cylinder. Please refer to the cylinder mountings on top of page B111.

Tandem Cylinders

In addition to the duplex cylinder options above, the P1D tie-rod version is also available as a tandem cylinder. By ordering two cylinders of equal strokes, mounted in series, and connecting the piston rods together, you achieve almost twice the output force, at the same pressure, as a standard cylinder. This is a great advantage when restricted mounting space prevents the use of a larger bore cylinder. Please review version and function options in the model code on page B94.

Cylinder Bore	A (mm)
32	247
40	277
50	293
63	323
80	355
100	385
125	461

S = Stroke

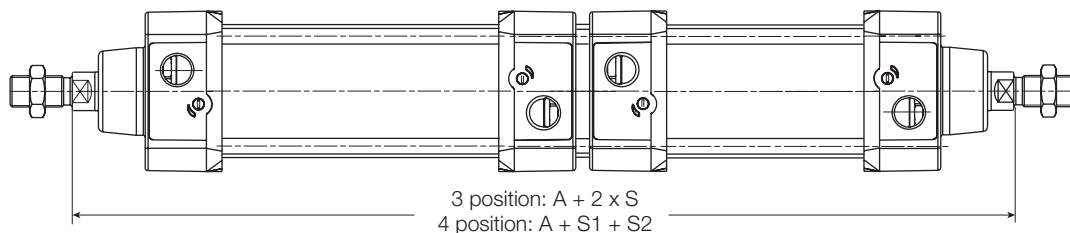

**B**  
Tie Rod Pneumatic Cylinders

Series 4MA  
Series 4MAJ  
Option ACVB  
Option LP50

Series P1D  
Series P1F  
Series 2MNR



For inventory, lead times, and kit lookup, visit [www.pdnplu.com](http://www.pdnplu.com)



**Flange - MF1 / MF2**



Intended for fixed mounting of cylinder. Flange can be fitted to front or rear end cover of cylinder.

**Materials:**

Flange: Surface-treated steel  
Mounting screws acc. to DIN 6912:  
Zinc-plated steel 8.8

Supplied complete with mounting screws for attachment to the cylinder.

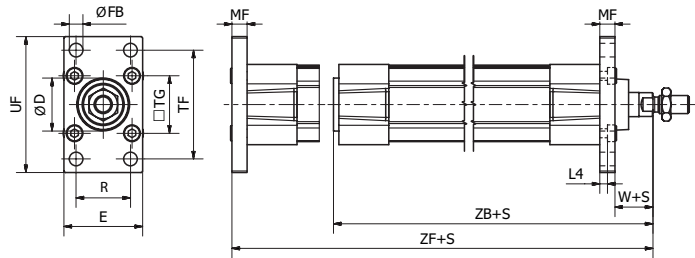

**According to ISO 15552**

Bore Size mm	D (H11) mm	E mm	ØFB (H13) mm	L4 mm	MF mm	R mm	TF mm	TG mm	UF mm	W* mm	ZB* mm	ZF* mm	Weight kg	Part Number
32	30	45	7	5.0	10	32	64	32.5	80	16	123.5	130	0.21	P1C-4KMB
40	35	52	9	5.0	10	36	72	38.0	90	20	138.5	145	0.27	P1C-4LMB
50	40	65	9	6.5	12	45	90	46.5	110	25	146.5	155	0.53	P1C-4MMB
63	45	75	9	6.5	12	50	100	56.5	120	25	161.5	170	0.66	P1C-4NMB
80	45	95	12	9.0	16	63	126	72.0	150	30	177.5	190	1.45	P1C-4PMB
100	55	115	14	9.0	16	75	150	89.0	170	35	192.5	205	1.60	P1C-4QMB
125	60	140	16	10.5	20	90	180	110.0	205	45	230.5	245	3.34	P1C-4RMB
160	65	180	18	9.5	20	115	230	140.0	279	60	266	280	7.2	P1C-4SMB
200	75	220	22	12.5	25	135	270	175.0	300	70	281	300	C.F.	P1C-4TMB

\*Does not apply to cylinders with piston rod extension or lock units.

**Foot Bracket - MS1**



Intended for fixed mounting of cylinder. Foot bracket can be fitted to front or rear end cover of the cylinder.

**Materials:**

Flange: Surface-treated steel  
Mounting screws acc. to DIN 6912:  
Zinc-plated steel 8.8:

Supplied complete with mounting screws for attachment to the cylinder.

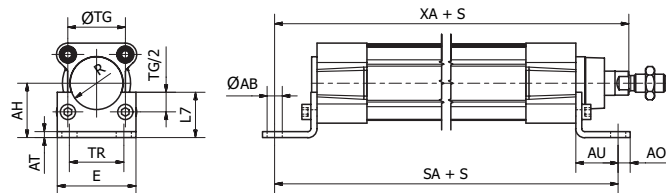

**According to ISO 15552**

Bore Size mm	ØAB (H14) mm	AH (JS15) mm	AO mm	AT mm	AU mm	E mm	L7 mm	R mm	SA* mm	TG mm	TR (JS14) mm	XA* mm	Weight ** kg	Part Number
32	7.0	32	11	4	24	45	30	15.0	142	32.5	32	144	0.08	P1C-4KMF
40	10.0	36	8	4	28	52	30	17.5	161	38.0	36	163	0.09	P1C-4LMF
50	10.0	45	15	5	32	65	36	20.0	170	46.5	45	175	0.18	P1C-4MMF
63	10.0	50	13	5	32	75	35	22.5	185	56.5	50	190	0.20	P1C-4NMF
80	12.0	63	14	6	41	95	47	22.5	210	72.0	63	215	0.40	P1C-4PMF
100	14.5	71	16	6	41	115	53	27.5	220	89.0	75	230	0.54	P1C-4QMF
125	16.5	90	25	8	45	140	70	30.0	250	110.0	90	270	1.10	P1C-4RMF
160	18	115	15	9	60	180	100	-	300	140.0	115	-	C.F.	P1C-4SMF
200	22	135	30	12	70	220	100	-	320	175.0	135	-	C.F.	P1C-4TMF

\*Does not apply to cylinders with piston rod extension or lock units.

\*\* per bracket

**B**  
Tie Rod Pneumatic Cylinders  
4MA Series  
4MAJ Series  
ACVB Option  
LPSO Option  
P1D Series  
P1F Series  
2MNR Series



For inventory, lead times, and kit lookup, visit [www.pdnplu.com](http://www.pdnplu.com)

**Pivot Bracket with Rigid Bearing - AB7**



Intended for flexible mounting of cylinder. The pivot bracket can be combined with clevis bracket MP2.

**Materials:**  
Pivot bracket: Aluminium  
(Bush: Steel and PTFE)

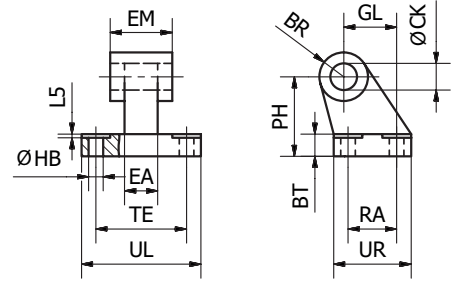

**According to ISO 15552**

Bore Size mm	CK mm	HB mm	L5 mm	TE mm	UL mm	GL mm	RA mm	EA mm	EM mm	UR mm	PH mm	BT mm	BR mm	Weight kg	Part Number
32	10	6.6	1.6	38	51	21	18	10	26	31	32	8	10.0	0.05	P1C-4KMDB
40	12	6.6	1.6	41	54	24	22	15	28	35	36	10	11.0	0.09	P1C-4LMDB
50	12	9.0	1.6	50	65	33	30	16	32	45	45	12	13.0	0.16	P1C-4MMDB
63	16	9.0	1.6	52	67	37	35	16	40	50	50	14	15.0	0.20	P1C-4NMDB
80	16	11.0	2.5	66	86	47	40	20	50	60	63	14	15.0	0.32	P1C-4PMDB
100	20	11.0	2.5	76	96	55	50	20	60	70	71	17	19.0	0.53	P1C-4QMDB
125	25	14.0	3.2	94	124	70	60	30	70	90	90	20	22.5	1.01	P1C-4RMDB
160	30	-	-	118	156	97	89	-	88.5	126	115	25	31.0	C.F.	P1C-4SMDB
200	30	-	-	122	162	105	89	-	88.5	130	135	30	31.0	C.F.	P1C-4TMDB

**Swivel Eye Bracket - MP6**

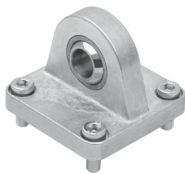

Intended for use together with clevis bracket AB6.

**Materials:**  
Bracket: Aluminium  
Swivel bearing acc. to DIN 648K:  
Hardened steel

Supplied complete with mounting screws for attachment to cylinder.

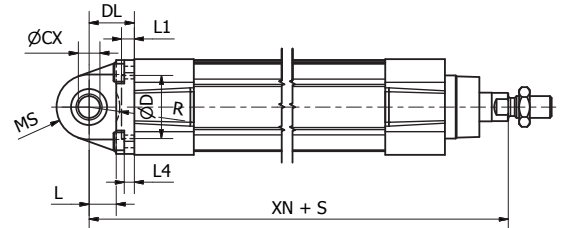
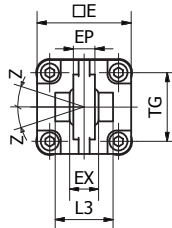

**According to ISO 15552**

Bore Size mm	CX mm	D mm	DL mm	E mm	EP mm	EX mm	L mm	L1 mm	L3 mm	L4 mm	MS mm	R mm	TG mm	XN* mm	Z mm	Weight kg	Part Number
32	10	30	22	45	10.5	14	12	7	-	5.5	16	-	32.5	142	4°	0.09	P1C-4KMSB
40	12	35	25	52	12	16	15	7	-	5.5	18	-	38	160	4°	0.13	P1C-4LMSB
50	16	40	27	65	15	21	15	7	51	6.5	21	19	46.5	170	4°	0.24	P1C-4MMSB
63	16	45	32	75	15	21	20	7	-	6.5	23	-	56.5	190	4°	0.29	P1C-4NMSB
80	20	45	36	95	18	25	20	9	74	10	28	24	72	210	4°	0.59	P1C-4PMSB
100	20	55	41	115	18	25	25	9	140	10	30	32	89	230	4°	0.78	P1C-4QMSB
125	30	60	50	140	25	37	30	9	-	10	40	-	110	275	4°	1.38	P1C-4RMSB
160	35	-	55	177	30	43	41	4	-	-	44	41	-	315	16°	C.F.	P1C-4SMSB
200	35	-	60	214	30	43	42	8	-	-	48	42	-	335	16°	C.F.	P1C-4TMSB

\*Does not apply to cylinders with piston rod extension or lock units.



For inventory, lead times, and kit lookup, visit [www.pdnplu.com](http://www.pdnplu.com)

**Clevis Bracket - MP2**

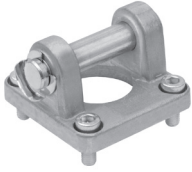

Intended for flexible mounting of cylinder. Can be combined with clevis bracket MP4 and pivot bracket with rigid bearing AB7.

**Materials:**

- Clevis bracket: Aluminium
- Pin: Surface hardened steel
- Locking pin: Spring steel
- Circlips according to DIN 471: Spring steel
- Mounting screws acc. to DIN 912: Zinc-plated steel 8.8

Supplied complete with mounting screws for attachment to the cylinder.

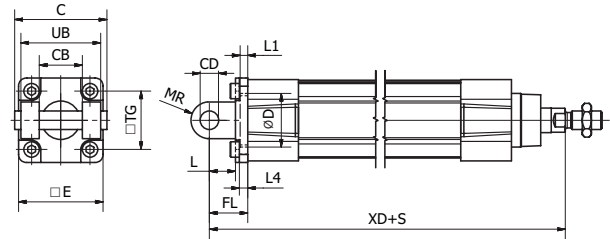

**According to ISO 15552**

Bore Size mm	C mm	E mm	UB mm	CB mm	TG mm	FL mm	L1 mm	L mm	L4 mm	D mm	CD mm	MR mm	XD* mm	Weight kg	Part Number
32	53	45	45	26	32.5	22	5	13	5.5	30	10	10	142	0.08	<b>P1C-4KMTB</b>
40	60	52	52	28	38	25	5	16	5.5	35	12	12	160	0.10	<b>P1C-4LMTB</b>
50	68	65	60	32	46.5	27	5	16	6.5	40	12	12	170	0.18	<b>P1C-4MMTB</b>
63	78	75	70	40	56.5	32	5	21	6.5	45	16	16	190	0.24	<b>P1C-4NMTB</b>
80	98	95	90	50	72	36	5	22	10	45	16	16	210	0.49	<b>P1C-4PMTB</b>
100	118	115	110	60	89	41	5	27	10	55	20	20	230	0.73	<b>P1C-4QMTB</b>
125	139	140	130	70	110	50	7	30	10	60	25	25	275	1.37	<b>P1C-4RMTB</b>
160	180	C.F.	170	90	C.F.	55	C.F.	35	C.F.	C.F.	30	25	315	2.20	<b>P1C-4SMTB</b>
200	220	C.F.	170	90	C.F.	60	C.F.	35	C.F.	C.F.	30	25	335	3.47	<b>P1C-4TMTB</b>

\*Does not apply to cylinders with piston rod extension or lock units.

**Clevis Bracket - MP4**



Intended for flexible mounting of cylinder. Clevis bracket MP4 can be combined with clevis bracket MP2.

**Materials:**

- Clevis bracket: Aluminium
- Bush: Steel and PTFE
- Mounting screws acc. to DIN 912: Zinc-plated steel 8.8

Supplied complete with mounting screws for attachment to the cylinder.

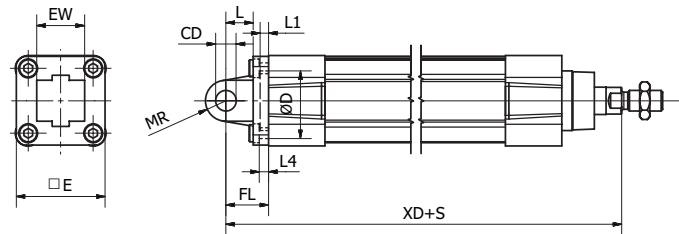

**According to ISO 15552**

Bore Size mm	CD mm	D mm	E mm	EW mm	FL mm	L mm	L1 mm	L4 mm	MR mm	XD* mm	Weight kg	Part Number
32	10	30	47	26	22	12	6.5	6	10.5	142	0.08	<b>P1C-4KMEB</b>
40	12	35	52	28	25	16	5	5.5	12	160	0.11	<b>P1C-4LMEB</b>
50	12	40	65	32	27	16	5	6.5	12	170	0.18	<b>P1C-4MMEB</b>
63	16	45	78	40	32	21	5	6.5	16	190	0.28	<b>P1C-4NMEB</b>
80	16	45	95	50	36	22	5	10	16	210	0.52	<b>P1C-4PMEB</b>
100	20	55	115	60	41	27	5	10	20	230	0.79	<b>P1C-4QMEB</b>
125	25	60	140	70	50	30	7	10	25	275	1.46	<b>P1C-4RMEB</b>
160	30	-	180	90	55	35	-	10	25	315	C.F.	<b>P1C-4SMEB</b>
200	30	-	220	90	60	35	-	14	25	335	C.F.	<b>P1C-4TMEB</b>

\*Does not apply to cylinders with piston rod extension or lock units.



For inventory, lead times, and kit lookup, visit [www.pdnplu.com](http://www.pdnplu.com)

**Clevis Bracket – AB6**



Intended for flexible mounting of cylinder.  
 Clevis bracket AB6 can be combined with pivot brackets MP6 and CS7 or swivel rod eye AP6.

**Materials:**

- Clevis bracket: Aluminium
- Pin: Surface hardened steel
- Locking pin: Spring steel
- Circlips according to DIN 471:
- Spring steel
- Mounting screws acc. to DIN 912:
- Zinc-plated steel 8.8
- Supplied complete with mounting screws for attachment to the cylinder.

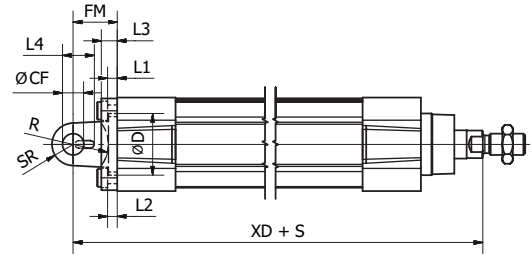
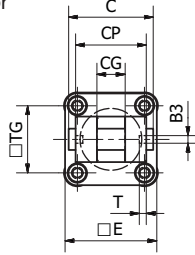

**According to ISO 15552**

Bore Size mm	B3 mm	C mm	CF mm	CG mm	CP mm	D mm	E mm	FM mm	I2 mm	T mm	R mm	L1 mm	L4 mm	L3 mm	SR mm	TG mm	XD* mm	Weight kg	Part Number
32	3.3	41	10	14	34	30	45	22	5.5	3	17	5	16.5	9	10	32.5	142	0.04	<b>P1C-4KMCB</b>
40	4.3	48	12	16	40	35	52	25	5.5	4	20	5	18	9	12	38	160	0.07	<b>P1C-4LMCB</b>
50	4.3	54	16	21	45	40	65	27	6.5	4	22	5	22	11	14	46.5	170	0.11	<b>P1C-4MMCB</b>
63	4.3	60	16	21	51	45	75	32	6.5	4	25	5	22	11	18	56.5	190	0.19	<b>P1C-4NMCB</b>
80	4.3	75	20	25	65	45	95	36	10.0	4	30	5	26	14	20	72	210	0.38	<b>P1C-4PMCB</b>
100	6.3	85	20	25	75	55	115	41	10.0	4	32	5	26	14	22	89	230	0.61	<b>P1C-4QMCB</b>
125	6.3	110	30	37	97	60	140	50	10.0	6	42	7	39	20	25	110	275	1.10	<b>P1C-4RMCB</b>

\*Does not apply to cylinders with piston rod extension or lock units.

**Head Detachable Clevis – MP7**

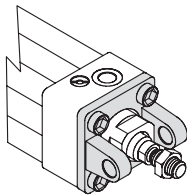

Intended for flexible mounting of cylinder

**Materials:**

- Clevis bracket: Cast iron for 32-63mm bores;
- Surface treated aluminum, black for 80-200mm bores
- Mounting screws acc. to DIN 912: Zinc-plated steel 8.8
- Supplied complete with mounting screws for attachment to cylinder.

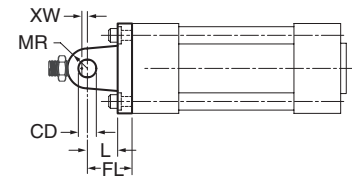
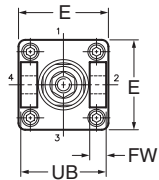

**According to ISO MP7, VDMA 24 562, AFNOR**

Bore Size mm	CD mm	E mm	FL mm	FW mm	L mm	MR mm	UB mm	XW mm	Part Number
32	10	46.5	22	8	12	10	45	4	<b>L075400032</b>
50	12	63.5	27	10	15	13	60	10	<b>L075400050</b>
63	16	76	32	15	20	16	70	5	<b>L075400063</b>
125	25	140	50	30	35	25	130	15	<b>L075400125</b>
160	30	177	55	40	36	30	170	25	<b>L075400160</b>



**Pivot Bracket with Swivel Bearing, CS7**



Intended for use together with clevis bracket AB6.

**Materials:**  
Pivot bracket: Aluminium  
Swivel bearing acc. to DIN 648K:  
Hardened steel

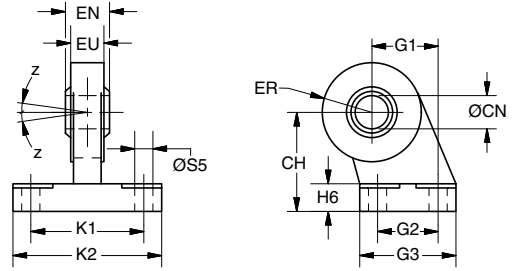

**According to ISO 15552**

Bore Size mm	CN mm	S5 mm	K1 mm	K2 mm	EU mm	G1 mm	G2 mm	EN mm	G3 mm	CH mm	H6 mm	ER mm	Z mm	Weight kg	Part Number
32	10	6.6	38	51	10.5	21	18	14	31	32	10	15	4°	0.18	<b>P1C-4KMAF</b>
40	12	6.6	41	54	12.0	24	22	16	35	36	10	18	4°	0.27	<b>P1C-4LMAF</b>
50	16	9.0	50	65	15.0	33	30	21	45	45	12	20	4°	0.46	<b>P1C-4MMAF</b>
63	16	9.0	52	67	15.0	37	35	21	50	50	12	23	4°	0.55	<b>P1C-4NMAF</b>
80	20	11.0	66	86	18.0	47	40	25	60	63	14	27	4°	0.97	<b>P1C-4PMAF</b>
100	20	11.0	76	96	18.0	55	50	25	70	71	15	30	4°	1.33	<b>P1C-4QMAF</b>
125	30	13.5	94	124	25.0	70	60	37	90	90	20	40	4°	3.00	<b>P1C-4RMAF</b>

**Mounting Kit**

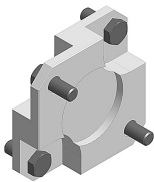

Mounting kit for back to back mounted cylinders, 3 and 4 position duplex cylinders.

**Materials:**  
Mounting: Aluminium  
Mounting screws: Zinc-plated steel 8.8

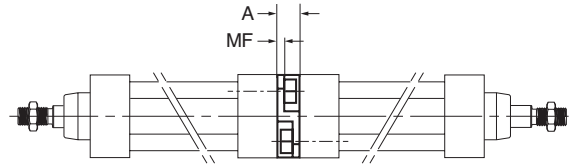

Bore Size mm	E mm	TG mm	ØFB mm	MF mm	A mm	ØBA mm	Weight kg	Part Number
32	50	32.5	6.5	5	16	30	0.060	<b>P1E-6KB0</b>
40	60	38.0	6.5	5	16	35	0.078	<b>P1E-6LB0</b>
50	66	46.5	8.5	6	20	40	0.162	<b>P1E-6MB0</b>
63	80	56.5	8.5	6	20	45	0.194	<b>P1E-6NB0</b>
80	100	72.0	10.5	8	25	45	0.450	<b>P1E-6PB0</b>
100	118	89.0	10.5	8	25	55	0.672	<b>P1E-6QB0</b>

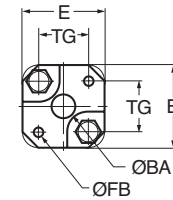

**Pivot Bracket – MT4**

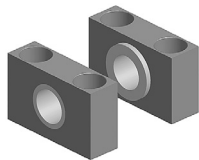

Intended for use together with central trunnion MT4.

**Materials:**  
Pivot bracket: Surface-treated aluminium  
Bearing acc. to DIN 1850 C: Sintered oil-bronze bushing  
Supplied in pairs.

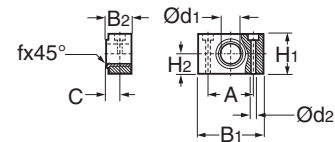

**According to ISO, VDMA 24 562, AFNOR**

Bore Size mm	B1 mm	B2 mm	A mm	C mm	d1 mm	d2 H13 mm	H1 mm	H2 mm	fx45° min mm	Weight* kg	Part Number
32	46	18.0	32	10.5	12	6.6	30	15	1.0	0.04	<b>9301054261</b>
40	55	21.0	36	12.0	16	9.0	36	18	1.6	0.07	<b>9301054262</b>
50	55	21.0	36	12.0	16	9.0	36	18	1.6	0.07	<b>9301054263</b>
63	65	23.0	42	13.0	20	11.0	40	20	1.6	0.12	<b>9301054264</b>
80	65	23.0	42	13.0	20	11.0	40	20	1.6	0.12	<b>9301054265</b>
100	75	28.5	50	16.0	25	14.0	50	25	2.0	0.21	<b>9301054266</b>
125	75	28.5	50	16.0	25	14.0	50	25	2.0	0.21	<b>9301054267</b>

\* Weight per item



For inventory, lead times, and kit lookup, visit [www.pdnplu.com](http://www.pdnplu.com)

**Intermediate Trunnion – MT4**

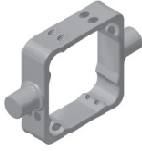

Standard\*

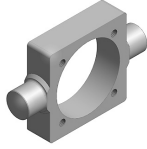

Tie Rod Version

Intended for articulated mounting of cylinder. The trunnion is factory-fitted at an optional location. Order by specifying Mounting Style G or 7 and providing the desired XV dimension (3-digit measure in mm). See page B95 for ordering information. Combined with pivot bracket for MT4 for 32-125mm bores.

**Materials:**

Trunnion: Zinc plated steel  
(Cast iron for 160-200mm bores)

\* Standard mounting is for the Standard cylinder body and is permanently affixed by the factory.

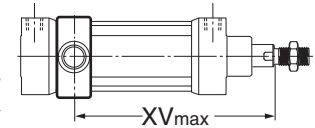
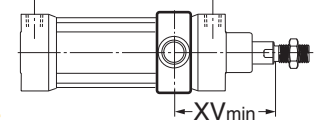
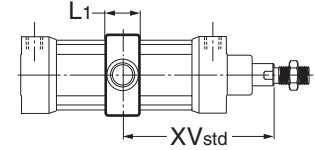
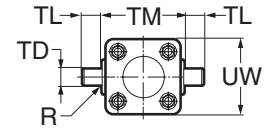

XV Standard for Rod Lock version:

$$\frac{L8 + \text{Stroke} + \text{WH}}{2}$$

**According to ISO MT4, VDMA 24 562, AFNOR**

Bore Size mm	TM h14 mm	TL h14 mm	TD e9 mm	R mm	UW mm	L1 P1D-G mm	L1 P1D-E mm	X1 mm	Standard "G"		Standard "7"		Tie Rod		Weight kg	
									XVmin mm	X2 mm	XVmin mm	X2 mm	XVmin mm	X2 mm		
32	50	12	12	1.0	46	18	15	73.0	84.0	76.0	94.0	62.0	84.0	62.0	84.0	0.13
40	63	16	16	1.6	59	20	20	82.5	91.0	82.0	103.0	74.0	73.0	92.0	92.0	0.31
50	75	16	16	1.6	69	20	20	90.0	108.5	89.5	107.5	71.5	80.5	99.5	99.5	0.37
63	90	20	20	1.6	84	26	25	97.5	111.0	93.5	126.0	84.0	89.5	106.0	106.0	0.69
80	110	20	20	1.6	102	26	25	110.0	125.0	109.5	143.0	95.0	98.0	122.0	122.0	0.89
100	132	25	25	2.0	125	32	30	120.0	132.5	114.5	167.5	107.5	110.5	129.5	129.5	1.58
125	160	25	25	2.0	155	33	32	145.0	160.0	142.0	188.0	130.0	132.0	158.0	158.0	2.60
160	200	32	32	2.5	190	-	70	170.0	154.0	186.0	-	-	169	C.F.	C.F.	
200	250	32	32	2.5	242	-	70	185.0	169.0	201.0	-	-	184	C.F.	C.F.	

$XV_{std} = X1 + \text{Stroke length}/2$

$XV_{max} = X2 + \text{Stroke length}$

C.F. = Consult Factory

**Flange Mounted Trunnion, J or H**

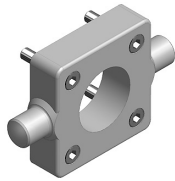

Intended for articulated mounting of cylinder. This trunnion can be flange mounted on the front or rear end cover of all P1D cylinders. If you choose, you can order a complete cylinder with factory-fitted flange mounted trunnion – see the ordering information on page B67 Individual trunnions have part numbers as shown below.

**Materials:**

Trunnion: zinc plated steel  
Screws: zinc plated steel, 8.8

Delivered complete with mounting screws for attachment to the cylinder

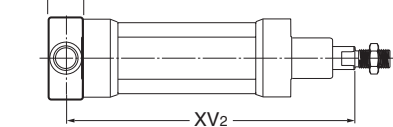
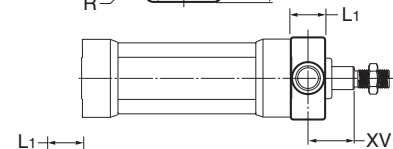
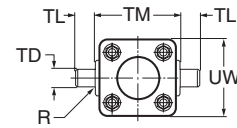

**According to ISO MT4, VDMA 24 562, AFNOR**

Bore Size mm	TM h14 mm	TL h14 mm	TD e9 mm	R mm	UW mm	L1 mm	XV <sub>1</sub> mm	X mm	Weight kg	Part Number
32	50	12	12	1.0	46	14	19.0	127.0	0.17	P1D-4KMYF
40	63	16	16	1.6	59	19	20.5	144.5	0.43	P1D-4LMYF
50	75	16	16	1.6	69	19	27.5	152.5	0.55	P1D-4MMYF
63	90	20	20	1.6	84	24	25.0	170.0	1.10	P1D-4NMYF
80	110	20	20	1.6	102	24	34.0	186.0	1.66	P1D-4PMYF
100	132	25	25	2.0	125	29	36.5	203.5	3.00	P1D-4QMYF

$XV_2 = X + \text{Stroke length}$



For inventory, lead times, and kit lookup, visit [www.pdnplu.com](http://www.pdnplu.com)

Swivel Rod Eye



Stainless Steel Swivel Rod Eye

Swivel rod eye for articulated mounting of cylinder.  
Swivel rod eye can be combined with clevis bracket GA.  
Maintenance-free.

**Materials:**

Swivel rod eye: Zinc-plated steel  
Swivel bearing according to DIN 648K: Hardened steel

Swivel rod eye: Stainless steel 304  
Swivel bearing according to DIN 648K: Stainless steel

Use stainless steel nut (see next page) with stainless steel swivel rod eye.

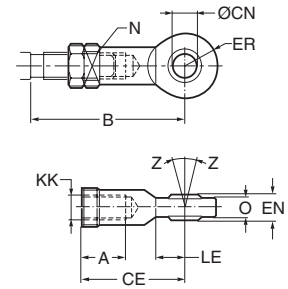

According to ISO 8139

Bore Size mm	A mm	B min mm	B max mm	CE mm	CN H9 mm	EN h12 mm	ER mm	KK	LE min mm	N mm	O mm	Z	Weight kg	Part Number	Stainless Steel Part Number
32	20	48.0	55	43	10	14	14	M10x1.25	15	17	10.5	12°	0.08	P1C-4KRS	P1S-4JRT
40	22	56.0	62	50	12	16	16	M12x1.25	17	19	12.0	12°	0.12	P1C-4LRS	P1S-4LRT
50	28	72.0	80	64	16	21	21	M16x1.5	22	22	15.0	15°	0.25	P1C-4MRS	P1S-4MRT
63	28	72.0	80	64	16	21	21	M16x1.5	22	22	15.0	15°	0.25	P1C-4PRS	P1S-4PRT
80	33	87.0	97	77	20	25	25	M20x1.5	26	32	18.0	15°	0.46	P1C-4RRS	P1S-4RRT
100	33	87.0	97	77	20	25	25	M20x1.5	26	32	18.0	15°	0.46	P1C-4SRS	-
125	51	123.5	137	110	30	37	35	M27x2	36	41	25.0	15°	1.28	P1C-4RRS	P1S-4RRT
160/200	56	C.F.	C.F.	125	35*	43	40	M36x2	40	50	28.0	15°	C.F.	P1C-4SRS	-

\*H7 C.F. = Consult Factory

Clevis

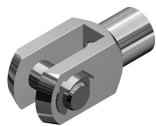

Stainless Steel Clevis

Clevis for articulated mounting of cylinder.

**Materials:**

Clevis, clip: Galvanized steel  
Pin: Hardened steel

Clevis: Stainless steel  
Pin: Stainless steel  
Circlips according to DIN 471: Stainless steel

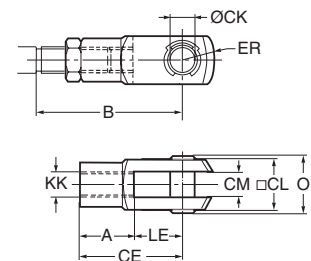

According to ISO 8140

Bore Size mm	A mm	B min mm	B max mm	CE mm	CK h11/E9 mm	CL mm	CM mm	ER mm	KK	LE mm	O mm	Weight kg	Part Number	Stainless Steel Part Number
32	20	45.0	52	40	10	20	10	16	M10x1.25	20	28.0	0.09	P1C-4KRC	P1S-4JRD
40	24	54.0	60	48	12	24	12	19	M12x1.25	24	32.0	0.15	P1C-4LRC	P1S-4LRD
50	32	72.0	80	64	16	32	16	25	M16x1.5	32	41.5	0.35	P1C-4MRC	P1S-4MRD
63	32	72.0	80	64	16	32	16	25	M16x1.5	32	41.5	0.35	P1C-4PRC	P1S-4PRD
80	40	90.0	100	80	20	40	20	32	M20x1.5	40	50.0	0.75	P1C-4RRC	P1S-4RRD
100	40	90.0	100	80	20	40	20	32	M20x1.5	40	50.0	0.75	P1C-4RRC	P1S-4RRD
125	56	123.5	137	110	30	55	30	45	M27x2	54	72.0	2.10	P1C-4RRC	P1S-4RRD
160/200	71	C.F.	C.F.	144	35	70	35	57	M36x2	72	95	C.F.	L075490036	Consult factory

C.F. = Consult Factory

B

Tie Rod Pneumatic Cylinders

4MA Series

4MAJ Series

ACVB Option

LPSO Option

P1D Series

P1F Series

2MNR Series



For inventory, lead times, and kit lookup, visit [www.pdnplu.com](http://www.pdnplu.com)

B113

Parker Hannifin Corporation  
Pneumatic Division  
Wadsworth, Ohio  
[www.parker.com/pneumatics](http://www.parker.com/pneumatics)



**Flexo Coupling**

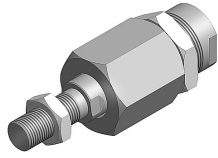

Flexo coupling for articulated mounting of piston rod. Flexo fitting is intended to take up axial angle errors within a range of  $\pm 4^\circ$ .

**Materials:**

Flexo coupling, nut: Zinc-plated steel  
 Socket: Hardened steel

Supplied complete with galvanized adjustment nut.

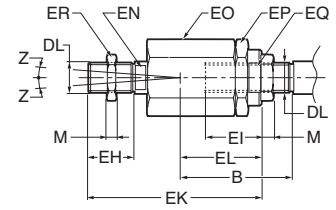

Bore Size mm	B min mm	B max mm	DL	EH mm	EI mm	EK mm	EL mm	EN mm	EO mm	EP mm	EQ mm	ER mm	M mm	Z	Weight kg	Part Number
32	36.0	43	M10x1.25	20	23	70	31	12	30	30	19	17	5.0	4°	0.21	<b>P1C-4KRF</b>
40	37.0	43	M12x1.25	24	23	77	31	12	30	30	19	19	6.0	4°	0.22	<b>P1C-4LRF</b>
50	53.0	61	M16x1.5	32	32	108	45	19	41	41	30	24	8.0	4°	0.67	<b>P1C-4MRF</b>
63	53.0	61	M16x1.5	32	32	108	45	19	41	41	30	24	8.0	4°	0.67	<b>P1C-4PRF</b>
80	57.0	67	M20x1.5	40	42	122	56	19	41	41	30	30	10.0	4°	0.72	<b>P1C-4PRF</b>
100	57.0	67	M20x1.5	40	42	122	56	19	41	41	30	30	10.0	4°	0.72	<b>P1C-4PRF</b>
125	75.5	89	M27x2	54	48	147	60	24	55	55	32	41	13.5	4°	1.80	<b>P1C-4RRF</b>
160/200	C.F.	C.F.	M36x2	72	50	241	C.F.	36	75	75	50	55	18.0	4°	C.F.	<b>P1C-4SRF</b>

C.F. = Consult Factory

**Nuts**



Intended for fixed mounting of accessories to the piston rod.

**Material:** Zinc-plated steel

All P1D cylinders are delivered with a zinc-plated steel piston rod nut.

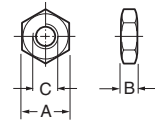

**Stainless Steel Nut**

**Material:** Stainless steel A2

**Acid-proof nut**

**Material:** Acid-proof steel A4

Cylinders with acid-proof piston rod are supplied with nut of acid-proof steel.

**According to DIN 439 B**

Bore Size mm	A mm	B mm	C	Weight kg	Part numbers		
					Steel	Stainless Steel	Acid-Proof
32	17	5.0	M10x1.25	0.007	<b>0867340300</b>	<b>9126725404</b>	
40	19	6.0	M12x1.25	0.010	<b>0867340400</b>	<b>9126725405</b>	<b>0261109920</b>
50	24	8.0	M16x1.5	0.021	<b>0867340600</b>	<b>9126725406</b>	<b>0261109917</b>
63	24	8.0	M16x1.5	0.021			<b>0261109911</b>
80	30	10.0	M20x1.5	0.040	<b>0867340900</b>	<b>0261109922</b>	<b>0261109918</b>
100	30	10.0	M20x1.5	0.040			<b>L075540036</b>
125	41	13.5	M27x2	0.100			
160/200	55	18.0	M36x2	C.F.			

C.F. = Consult Factory

**B**  
 Tie Rod Pneumatic Cylinders  
 4MA Series  
 4MAJ Series  
 ACVB Option  
 LPSO Option  
 P1D Series  
 P1F Series  
 2MNR Series



For inventory, lead times, and kit lookup, visit [www.pdnplu.com](http://www.pdnplu.com)

**Grease for P1D Series**



Size	Part Number
30g (standard)	<b>9127394541</b>

**Gland Service Kits: P1D-G and P1D-E Versions**

Bore Size mm	Rod Dia. mm	Rod No.	RG-rod gland cartridge kit Consisting of: rod gland, seals, and wiper	
			Nitrile Seals Part Number	Fluorocarbon Seals Part Number
32	12	1	<b>RG0P1D0121</b>	<b>RG0P1D0125</b>
40	16	1	<b>RG0P1D0161</b>	<b>RG0P1D0165</b>
50 & 63	20	1	<b>RG0P1D0201</b>	<b>RG0P1D0205</b>
80 & 100	25	1	<b>RG0P1D0251</b>	<b>RG0P1D0255</b>
125	32	1	<b>RG0P1D0321</b>	<b>RG0P1D0325</b>
160 & 200	40	1	<b>RG0P1D0401</b>	<b>RG0P1D0405</b>

RK-rod seal kit Consisting of: gland seals, and wiper	
Nitrile Seals Part Number	Fluorocarbon Seals Part Number
<b>RK0P1D0121</b>	<b>RK0P1D0125</b>
<b>RK0P1D0161</b>	<b>RK0P1D0165</b>
<b>RK0P1D0201</b>	<b>RK0P1D0205</b>
<b>RK0P1D0251</b>	<b>RK0P1D0255</b>
<b>RK0P1D0321</b>	<b>RK0P1D0325</b>

**Piston and End Seal Service Kits:  
P1D-G and P1D-E Versions**

Bore Size mm	PK – piston seal kit Consisting of: piston seals, wear ring, cylinder body o-rings, and magnetic strip (nitrile only)	
	Nitrile Seals Part Number	Fluorocarbon Seals Part Number
32	<b>PK032P1D01</b>	<b>PK032P1D05</b>
40	<b>PK040P1D01</b>	<b>PK040P1D05</b>
50	<b>PK050P1D01</b>	<b>PK050P1D05</b>
63	<b>PK063P1D01</b>	<b>PK063P1D05</b>
80	<b>PK080P1D01</b>	<b>PK080P1D05</b>
100	<b>PK100P1D01</b>	<b>PK100P1D05</b>
125	<b>PK125P1D01</b>	<b>PK125P1D05</b>
160	<b>PK160MP001</b>	<b>PK160MP005</b>
200	<b>PK200MP001</b>	<b>PK200MP005</b>

**B**

Tie Rod Pneumatic  
Cylinders

4MA  
Series

4MAJ  
Series

ACVB  
Option

LPSO  
Option

P1D  
Series

P1F  
Series

2MNR  
Series



Features

**P1F Profile Series – 32mm to 125mm Bore Size**

**Standard Cylinders ISO 15552**

**Global product range**

The P1F Series meets the specifications of the ISO 15552 standard. This means full interchangeability to any ISO cylinder anywhere around the globe. P1F will be available throughout the extensive worldwide Parker Hannifin organization.



**Features**

- Smooth profile or tie-rod design
- Bore sizes 32 - 125 mm
- Corrosion resistant design with end plates and barrel in sandblast and anodized aluminum
- Magnetic piston standard
- Polyurethane seal technology inside
- Cushioning stainless steel screws on same side
- New adjustable pneumatic and mechanical cushioning system reduces the noise caused by the impact of the piston on the end covers (standard)
- Full range of mountings available
- Full range of 'drop-in' sensors available



**Design Variants**

**Smooth profile - P1F-S, P1F-K**

The P1F in bore sizes Ø32 to Ø125 mm is a smooth profile designed cylinder with a magnetic piston used for standard temperature range from -20°C to +80°C. Utilizing internal composite technology to save weight and reduce impact kinetic energy, while assuring the high performance and functionality expected for an ISO cylinder. Aluminum end covers, carbon steel piston rod guided with a PTFE coated steel bearing, pneumatic cushioning and polyurethane (PUR) seals as standard, this is our smooth profile industrial ISO cylinder.

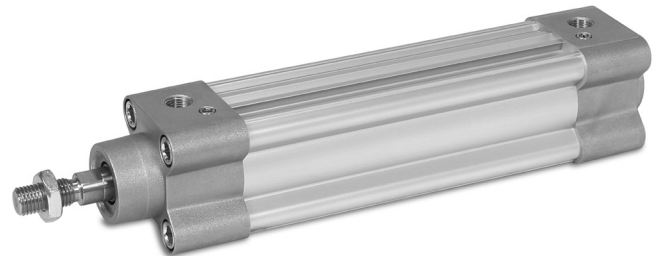

[www.parker.com/pdn/P1F-S](http://www.parker.com/pdn/P1F-S)

CE Ex II 2GD Ex h IIC T4 T=120°C GDb -20°C ≤ Ta ≤ +60°C

**Tie-Rod round profile - P1F-T, P1F-N**

Similar to the smooth profile version but in a Tie-Rod design for heavy duty applications. Round tube is made in anodized aluminum; Tie-rod in stainless steel as a standard.



[www.parker.com/pdn/P1F-T](http://www.parker.com/pdn/P1F-T)

B	Tie Rod Pneumatic Cylinders
	Series 4MA
	Series 4MAJ
	Option ACVB
	Option LP50
	Series P1D
	Series P1F
	Series 2MNR



For inventory, lead times, and kit lookup, visit [www.pdnplu.com](http://www.pdnplu.com)

## Features

### Smooth profile with rod locks - P1F-L

The rod lock incorporates a powerful piston rod locking device, which clamps the piston rod and locks it in position. The lock is spring activated and engages when air pressure is lost. The lock is integrated into the front (head) cover of the cylinder.

## Tie Rod Pneumatic Cylinders P1F Series

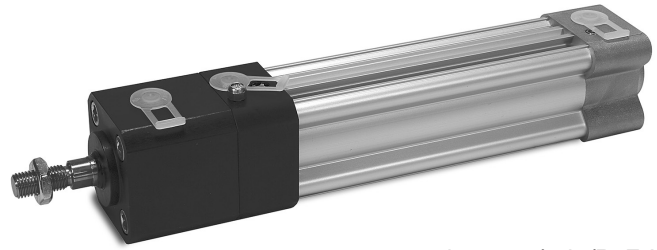

[www.parker.com/pdn/P1F-L](http://www.parker.com/pdn/P1F-L)

### Air Reservoirs - P1F-P

Air reservoirs are produced by a cylinder tube and two standard rear end plates and used, e.g. together with throttle valves to achieve a timer function in a pneumatic system. The delay of time will be varied by changing the throttle valve and by the size of the air reservoir. With a well functioning throttle valve and a suitable air reservoir it would be possible to achieve an accuracy of  $\pm 5\%$ . The reservoir is also used to equal pressure variants into system and to handling short extreme air consumptions without functional disorders. The air reservoirs could also be used together with check valves in order to retain a pressure which is essential for safety reasons.



## Options

### High temperature option

All seals in the high temperature version of P1F are developed and validated for continuous operation up to  $+150^{\circ}\text{C}$ . The combination of the seal geometry and the FKM (fluoro elastomers) material ensures reliable and long service life. High temperature cylinders have no magnetic piston and cannot be fitted with sensors (the magnetic field strength in high temperatures is too low to ensure correct reliable sensor function).

### Low temperature option

All seals in the low temperature version of P1F are developed and validated for continuous operation down to  $-40^{\circ}\text{C}$ . Ultrathane polyurethane TPU-PUR seal technology and specifically formulated grease support performance and reliability for low temperature applications. As standard supplied with a magnetic ring in the piston for proximity sensing.

### Metallic scraper option

In environments where the piston rod may be coated with resin, ice, cement, sugar crystals, dough, etc., primarily in timber handling, refrigerated/chilled transport, cement industry, chemicals and food and drinks a metal scraper in combination with a hard-chromium plated piston rod is the right solution. Available for low temperature range applications from  $-30^{\circ}\text{C}$  to  $+80^{\circ}\text{C}$ .

**B**

Tie Rod Pneumatic  
Cylinders

4MA  
Series

4MAJ  
Series

ACVB  
Option

LPSO  
Option

P1D  
Series

P1F  
Series

2MNR  
Series

Ordering Information

Ordering Information

**P1F - S 032 M C - 0160 - 0000**

<b>Series</b>	
P1F	Global ISO

<b>Profile/Cylinder Design</b>	
S	Smooth
K	Smooth with Through Rod
L	Smooth with Dynamic Rod Lock <sup>1</sup>
T	Tie-Rod
N	Tie-Rod with Through Rod
P	Air Reservoir <sup>1</sup>

<b>Cylinder Bore Size</b>	
032	32mm
040	40mm
050	50mm
063	63mm
080	80mm
100	100mm
125	125mm

<b>Cylinder Stroke</b>	
....	Stroke length in mm (max. 2000)

<b>Rod Extension or Trunnion Mounting</b>	
0000	Without
P...	Piston Rod Extension in mm
6000	Trunnion Mount +90° vs. Air Ports
7000	Trunnion Mount +0° vs. Air Ports
H...	Piston Rod Extension in mm with Trunnion +90°
8...	Piston Rod Extension in mm with Trunnion +0°
3...	Special Rod End

<b>Piston Style</b>	
-	Standard with Magnet <sup>1,4</sup>
F	Standard w/o Magnet <sup>1</sup>
X	Aluminum with Magnet
A	Aluminum w/o Magnet

<b>Temperature Range</b>	
M	Polyurethane (PUR) -20°C to +80°C Std Temp
F	Fluoro Elastomere (FKM) -10°C to +150°C High Temp <sup>2</sup>
L	Ultrathane Polyurethane (TPU-PUR) -40°C to +80°C Low Temp <sup>2</sup>
Q	(TPU-PUR) with Metallic Scraper -30°C to +80°C Low Temp <sup>2</sup>

<b>Piston Rod Material Male Thread</b>	
C	Chrome Plated Carbon Steel
R	Chrome Plated Stainless Steel (17-4)

<b>Piston Rod Material Female Thread</b>	
F	Chrome Plated Carbon Steel
G	Chrome Plated Stainless Steel (17-4)

<b>Air Reservoir</b>	
A	Without Piston Rod <sup>4</sup>

**Sensors**  
See section L for sensors. 

<sup>1</sup> In standard temperature range -20°C to +80°C  
<sup>2</sup> High and low temp option only with aluminum piston  
<sup>4</sup> For air reservoir

**Standard strokes for all P1F cylinders compliant to ISO 4393**  
(with the exception of stroke 40 mm)

Non standard strokes up to 2000 mm.

**P1F Cylinders in Stock, Cushions and Magnetic Piston Included**

Stroke (mm)	32 mm Bore	40 mm Bore	50 mm Bore	63 mm Bore	80 mm Bore
25	P1F-S032MC-0025-0000	P1F-S040MC-0025-0000	P1F-S050MC-0025-0000	P1F-S063MC-0025-0000	P1F-S080MC-0025-0000
40	P1F-S032MC-0040-0000	P1F-S040MC-0040-0000	P1F-S050MC-0040-0000	P1F-S063MC-0040-0000	P1F-S080MC-0040-0000
50	P1F-S032MC-0050-0000	P1F-S040MC-0050-0000	P1F-S050MC-0050-0000	P1F-S063MC-0050-0000	P1F-S080MC-0050-0000
80	P1F-S032MC-0080-0000	P1F-S040MC-0080-0000	P1F-S050MC-0080-0000	P1F-S063MC-0080-0000	P1F-S080MC-0080-0000
100	P1F-S032MC-0100-0000	P1F-S040MC-0100-0000	P1F-S050MC-0100-0000	P1F-S063MC-0100-0000	P1F-S080MC-0100-0000
125	P1F-S032MC-0125-0000	P1F-S040MC-0125-0000	P1F-S050MC-0125-0000	P1F-S063MC-0125-0000	P1F-S080MC-0125-0000
160	P1F-S032MC-0160-0000	P1F-S040MC-0160-0000	P1F-S050MC-0160-0000	P1F-S063MC-0160-0000	P1F-S080MC-0160-0000
200	P1F-S032MC-0200-0000	P1F-S040MC-0200-0000	P1F-S050MC-0200-0000	P1F-S063MC-0200-0000	P1F-S080MC-0200-0000
250	P1F-S032MC-0250-0000	P1F-S040MC-0250-0000	P1F-S050MC-0250-0000	P1F-S063MC-0250-0000	P1F-S080MC-0250-0000
320	P1F-S032MC-0320-0000	P1F-S040MC-0320-0000	P1F-S050MC-0320-0000	P1F-S063MC-0320-0000	P1F-S080MC-0320-0000
400	P1F-S032MC-0400-0000	P1F-S040MC-0400-0000	P1F-S050MC-0400-0000	P1F-S063MC-0400-0000	P1F-S080MC-0400-0000



For inventory, lead times, and kit lookup, visit [www.pdnplu.com](http://www.pdnplu.com)

**Cylinder forces**

Bore/Piston Rod [mm]	Stroke	Surface Area [cm <sup>2</sup> ]	Max Theoretical Force in N in Relation to Applied Pressure in Bar									
			1	2	3	4	5	6	7	8	9	10
32/12	+	8.0	80	161	241	322	402	483	563	643	724	804
	-	6.9	69	138	207	276	346	415	484	553	622	691
40/16	+	12.6	126	251	377	503	628	754	880	1005	1131	1257
	-	10.6	106	211	317	422	528	633	739	844	950	1056
50/20	+	19.6	196	393	589	785	982	1178	1374	1571	1767	1964
	-	16.5	165	330	495	660	825	990	1155	1319	1484	1649
63/20	+	31.2	312	623	935	1247	1559	1870	2182	2494	2806	3117
	-	28.0	280	561	841	1121	1402	1682	1962	2242	2523	2803
80/25	+	50.3	503	1005	1508	2011	2513	3016	3519	4021	4524	5027
	-	45.4	454	907	1361	1814	2268	2721	3175	3629	4082	4536
100/25	+	78.5	785	1571	2356	3142	3927	4712	5498	6283	7069	7854
	-	73.6	736	1473	2209	2945	3682	4418	5154	5891	6627	7363
125/32	+	122.7	1227	2454	3682	4909	6136	7363	8590	9818	11045	12272
	-	114.7	1147	2294	3440	4587	5734	6881	8027	9174	10321	11468

+ = outward stroke  
 - = return stroke

**Cylinder air consumption**

Bore/Piston Rod [mm]	Stroke	Surface Area [cm <sup>2</sup> ]	Air Consumption in l/mm in Relation to Applied Pressure in Bar									
			1	2	3	4	5	6	7	8	9	10
32/12 (G1/8)	+	8.0	0.016	0.024	0.032	0.040	0.048	0.056	0.064	0.072	0.079	0.087
	-	6.9	0.014	0.021	0.027	0.034	0.041	0.048	0.055	0.061	0.068	0.075
40/16 (G1/4)	+	12.6	0.025	0.037	0.050	0.062	0.075	0.087	0.099	0.112	0.124	0.137
	-	10.6	0.021	0.031	0.042	0.052	0.063	0.073	0.083	0.094	0.104	0.115
50/20 (G1/4)	+	19.6	0.039	0.058	0.078	0.097	0.117	0.136	0.155	0.175	0.194	0.213
	-	16.5	0.033	0.049	0.065	0.082	0.098	0.114	0.130	0.147	0.163	0.179
63/20 (G3/8)	+	31.2	0.062	0.093	0.123	0.154	0.185	0.216	0.247	0.277	0.308	0.339
	-	28.0	0.056	0.083	0.111	0.139	0.166	0.194	0.222	0.249	0.277	0.305
80/25 (G3/8)	+	50.3	0.100	0.150	0.199	0.249	0.298	0.348	0.398	0.447	0.497	0.546
	-	45.4	0.090	0.135	0.180	0.224	0.269	0.314	0.359	0.404	0.448	0.493
100/25 (G1/2)	+	78.5	0.156	0.234	0.311	0.389	0.466	0.544	0.621	0.699	0.776	0.854
	-	73.6	0.146	0.219	0.292	0.364	0.437	0.510	0.582	0.655	0.728	0.800
125/32 (G1/2)	+	122.7	0.244	0.365	0.486	0.607	0.728	0.850	0.971	1.092	1.213	1.334
	-	114.7	0.228	0.341	0.454	0.567	0.681	0.794	0.907	1.020	1.134	1.247

+ extending, - retracting

free air consumption for 1 cycle, 10 mm inward and 10 mm outward

**Weight**

Bore Size mm	P1F-S/L		P1F-T		Moving Parts		Adder for Rod Lock P1F-L kg
	Base 0 mm kg	per 100 mm kg	Base 0 mm kg	per 100 mm kg	Base 0 mm kg	per 100 mm kg	
32	0.54	0.23	0.49	0.27	0.10	0.09	0.41
40	0.74	0.32	0.73	0.31	0.19	0.16	0.44
50	1.22	0.47	1.19	0.52	0.34	0.25	0.61
63	1.69	0.49	1.68	0.54	0.40	0.24	1.25
80	2.50	0.73	2.48	0.84	0.73	0.39	2.45
100	3.65	0.80	3.66	0.88	1.02	0.38	3.72
125	6.41	1.37	6.30	1.32	2.01	0.63	6.07

**B**

Tie Rod Pneumatic Cylinders

4MA Series

4MAJ Series

ACVB Option

LPSO Option

P1D Series

P1F Series

2MNR Series



For inventory, lead times, and kit lookup, visit [www.pdnplu.com](http://www.pdnplu.com)

B119

**Parker Hannifin Corporation**  
 Pneumatic Division  
 Wadsworth, Ohio  
[www.parker.com/pneumatics](http://www.parker.com/pneumatics)



Product type	Standard cylinder according to ISO 15552
Bore size	32 - 125 mm
Stroke length	25 - 2000 mm
Versions	Double acting
Cushioning	Adjustable air cushioning
Position sensing	Proximity sensor
Installation	ISO cylinder and piston rod mountings

**Operating and environmental data**

Operating medium	For best possible service life and trouble-free operation dry filtered compressed air to ISO 8573-1:2010 quality 3.4.3 should be used. This specifies a dew point of + 3°C for indoor operation (a lower dew point should be selected for minus temperature operation and we recommend the use of an inline dryer) and is in line with the air quality from most standard compressors with a standard filter.
Operating pressure	1 to 10 bar
Ambient temperature	Standard temperature (option M): -20°C to +80°C High temperature (option F): -10°C to +150°C Low temperature (option L): -40°C to + 80°C Metal scraper (option Q): -30°C to +80°C
Pre-lubricated	Further lubrication is normally not necessary. If additional lubrication is introduced it must be continued. Hydraulic oil type HLP (DIN 51524, ISO 11158). Viscosity by 40°C: 32 mm2/s (cst). Example: Shell Tellus 32 or equal.
Corrosion resistance	Material and surface treatment selected for typical industrial applications with resistance to corrosion and chemicals.

<b>B</b>	Tie Rod Pneumatic Cylinders
4MA Series	
4MAJ Series	
ACVB Option	
LPS0 Option	
P1D Series	
P1F Series	
2MNR Series	



For inventory, lead times, and kit lookup, visit [www.pdnplu.com](http://www.pdnplu.com)

**B120**

**Parker Hannifin Corporation**  
 Pneumatic Division  
 Wadsworth, Ohio  
[www.parker.com/pneumatics](http://www.parker.com/pneumatics)



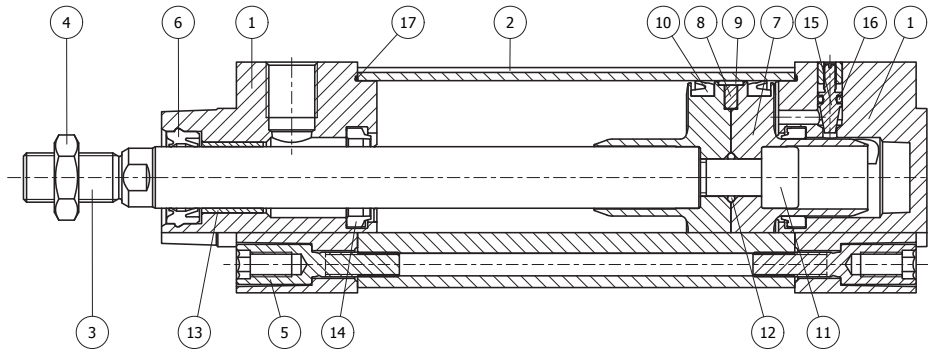

**Material specification**

Pos	Part	Specification
1	End covers	Aluminum
2	Cylinder barrel	Anodized aluminum (profile or round tube)
3	Piston rod	Standard Chrome plated carbon steel
		Optional Chrome plated stainless steel (17-4)
4	Piston rod nut	Zinc plated steel
5	End cover screws	Zinc plated steel
6	Piston rod seal	Standard Polyurethane (PUR)
		Optional Fluoro elastomer (FKM) / Ultrathanpolyurethane (TPU-PUR) / Metallic scraper (Brass) nitrile (NBR) / Polon / UHMW-PE
7	Piston	Standard Poloxymethylene (POM)
		Optional Aluminum
8	Magnet	Plastic coated magnetic material
9	Piston bearing	Standard Poloxymethylene (POM)
		Optional Polytetrafluoroethylene (PTFE)
10	Piston seals	Standard Polyurethane (PUR)
		Optional Fluoro elastomer (FKM) / Ultrathanpolyurethane (TPU-PUR)
11	Piston bolt	Zinc plated steel
12	O-ring piston bolt	Standard Nitrile rubber (NBR)
		Optional Fluoro elastomer (FKM)
13	Piston rod bearing	Multilayer steel / PTFE
14	Cushioning seals	Standard Polyurethane (PUR)
		Optional Fluoro elastomer (FKM) / Ultrathanpolyurethane (TPU-PUR)
15	Cushioning screw	Stainless steel DIN X8 CrNiS 18-9
16	O-ring cushioning screw	Standard Nitrile rubber (NBR)
		Optional Fluoro elastomer (FKM)
17	O-ring end cover	Standard Nitrile rubber (NBR)
		Optional Fluoro elastomer (FKM)
	Tie-rod	Austenitic stainless steel, DIN X8 CrNiS 18-9
	Tie-rod nut	Zinc plated steel

**B**

Tie Rod Pneumatic Cylinders

4MA Series

4MAJ Series

ACVB Option

LPSO Option

P1D Series

P1F Series

2MNR Series



For inventory, lead times, and kit lookup, visit [www.pdnplu.com](http://www.pdnplu.com)

B121

**Parker Hannifin Corporation**  
Pneumatic Division  
Wadsworth, Ohio  
[www.parker.com/pneumatics](http://www.parker.com/pneumatics)

**Guide for selecting suitable tubing**

The selection of the correct size of tubing is often based on experience, with no great thought to optimizing energy efficiency and cylinder velocity. This is usually acceptable, but making a rough calculation can result in worthwhile economic gains.

**The following is the basic principle:**

1. The primary line to the working valve could be over sized (this does not cause any extra air consumption and consequently does not create any extra costs in operation).
2. The tubes between the valve and the cylinder should, however, be optimized according to the principle that an insufficient bore throttles the flow and thus limits the cylinder speed, while an oversized pipe creates a dead volume which increases the air consumption and filling time.

**The following prerequisites apply**

The cylinder load should be about 50 % of the theoretical force (= normal load). A lower load gives a higher velocity and vice versa. The tube size is selected as a function of the cylinder bore, the desired cylinder velocity and the tube length between the valve and the cylinder. If you want to use the capacity of the valve to its maximum, and obtain maximum speed, the tubing should be chosen so that they at least correspond with the equivalent restriction diameter (see description below), so that the tubing does not restrict the total flow. This means that a short tubing must have at least the equivalent restriction diameter. If the tubing is longer, choose it from the table below. Straight fittings should be chosen highest flow rates. Rates as elbow and banjo fittings cause restriction.

The chart below is intended to help when selecting the correct size of tube to use between the valve and the cylinder.

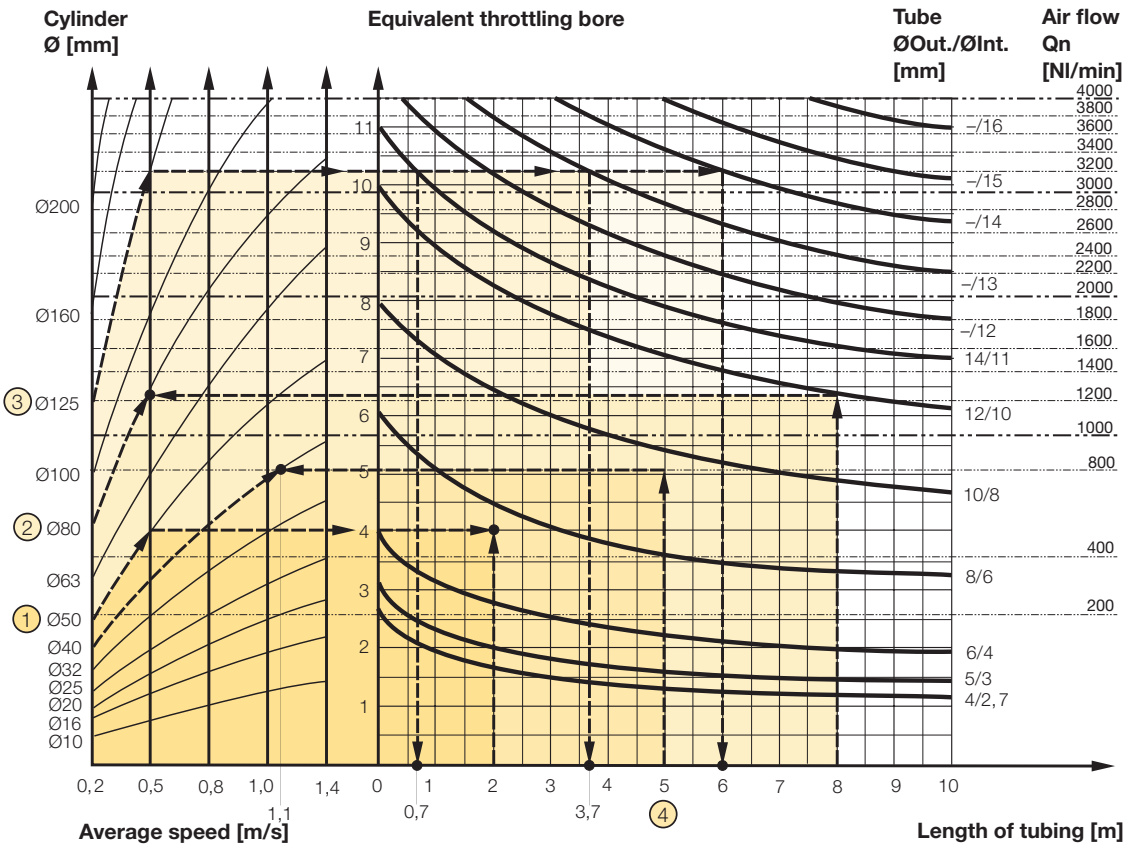

The equivalent throttling bore is a long throttle (for example a tube) or a series of throttles (for example, through a valve) converted to a short throttle which gives a corresponding flow rate. This should not be confused with the orifice which is sometimes specified for valves. The value for the orifice does not normally take account of the fact that the valve contains a number of throttles.

Qn is a measure of the valve flow capacity, with flow measured in liter per minute (l/min) at 6 bar(e) supply pressure and 1 bar pressure drop across the valve.

**B**  
Tie Rod Pneumatic Cylinders

Series 4MA  
Series 4MAJ  
Option ACVB  
Option LPSO  
Series P1D  
Series P1F  
Series 2MNR



For inventory, lead times, and kit lookup, visit [www.pdnplu.com](http://www.pdnplu.com)

**Example ① :**  
**Which tube diameter should be used?**

A 50 mm bore cylinder is to be operated at 0.5 m/s. The tube length between the valve and cylinder is 2 m. In the diagram we follow the line from 50 mm bore to 0.5 m/s and get an “equivalent throttling bore” of approximately 4 mm. We continue out to the right in the chart and intersect the line for a 2 m tube between the curves for 4 mm (6/4 tube) and 6 mm (8/6 tube). This means that a 6/4 tube throttles the velocity somewhat, while an 8/6 tube is a little too large. We select the 8/6 tube to obtain full cylinder velocity.

**Example ② :**  
**What cylinder velocity will be obtained?**

A 80 mm bore cylinder will be used, connected by 8 m 12/10 tube to a valve with Qn 1200 NI/min. What cylinder velocity will we get? We refer to the diagram and follow the line from 8 mm tube length up to the curve for 12/10 tube. From there, we go horizontally to the curve for the Ø80 cylinder. We find that the velocity will be about 0.5 m/s.

**Example ③ :**  
**What is the minimum inner diameter and maximum length of tube?**

For an application a 125 mm bore cylinder will be used. Maximum velocity of piston rod is 0.5 m/s. The cylinder will be controlled by a valve with Qn 3200 NI/min. What diameter of tube can be used and what is maximum length of tube. We refer to the diagram. We start at the left side of the diagram cylinder Ø125. We follow the line until the intersection with the velocity line of 0.5 m/s. From here we draw a horizontal

line in the diagram. This line shows us we need an equivalent throttling bore of approximately 10 mm.

Following this line horizontally we cross a few intersections. These intersections shows us the minimum inner diameter (right side diagram) in combination with the maximum length of tube (bottom side diagram).

**For example:**

Intersection one: When a tube (14/11) will be used, the maximum length of tube is 0.7 meter.

Intersection two: When a tube (—/13) will be used, the maximum length of tube is 3.7 meter.

Intersection three: When a tube (—/14) will be used, the maximum length of tube is 6 meter.

**Example ④ : Determining tube size and cylinder velocity with a particular cylinder and valve?**

For an application using a 40 mm bore cylinder with a valve with Qn=800 NI/min. The distance between the cylinder and valve has been set to 5 m.

Tube dimension: What tube bore should be selected to obtain the maximum cylinder velocity? Start at pipe length 5 m, follow the line up to the intersection with 800 NI/min. Select the next largest tube diameter, in this case Ø10/8 mm.

Cylinder velocity: What maximum cylinder velocity will be obtained? Follow the line for 800 NI/min to the left until it intersects with the line for the Ø40 mm cylinder. In this example, the speed is just above 1.1 m/s.

**Cushioning Diagram**

Work out your expected moving mass and read off the maximum permissible speed at start of cushioning.

Alternatively, take your desired speed and expected mass and find the cylinder size required.

Please note that piston speed at start of cushioning is typically approx. 50% higher than the average speed, and that it is this higher speed which determines the choice of cylinder.

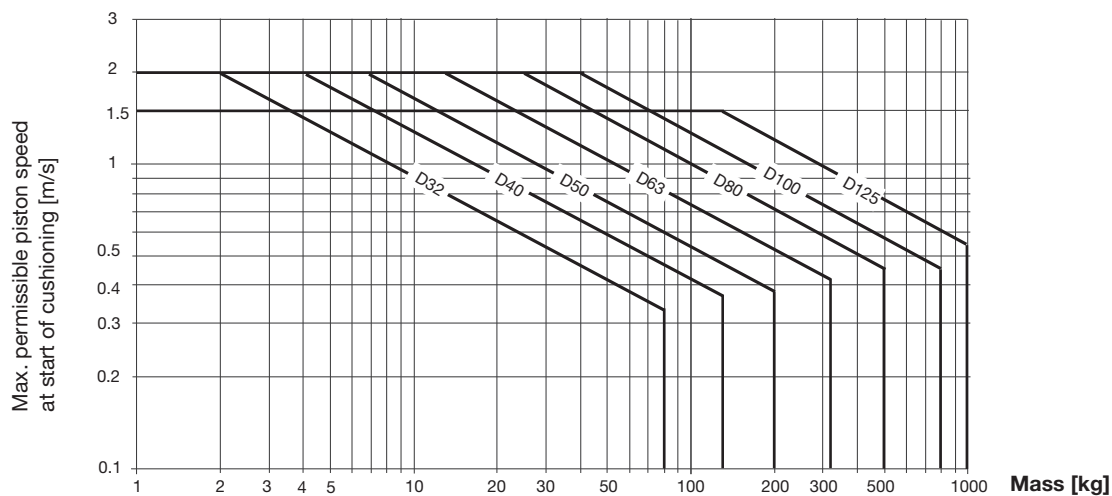

Horizontal application, pressure p = 6 bar, mass guided externally

<b>B</b>	Tie Rod Pneumatic Cylinders
4MA Series	4MAJ Series
ACVB Option	LPSO Option
P1D Series	P1F Series
2MNR Series	

**Cylinder with Rod Lock**

**Function on pressure loss**

The piston rod lock can be used in all material handling systems where controlled fastening or positioning is required. Additional measures are required for use in safety-related applications (refer to EC Machinery Directive).

The piston rod cylinder with brakes is suitable for use in safety-related sections of control systems. The piston rod lock is also suitable for use as a pressure-loss brake for cylinders with suspended loads, for example. Piston rod can be held in position for long periods even with alternating loads, fluctuating operating pressure or leaks in the system. The signal air to the lock unit can be connected directly to the air system or to the supply air for the valve controlling the cylinder in question. For controlled on/off operation of the lock unit, a separate valve, with large exhaust flow capacity, is used.

**Clean and compact design**

The front end piece and lock unit form an integrated block, keeping the length of the structure short. The design is easy to clean, sealed and waterproof. The exhaust air from the lock unit can be removed by replacing the filter unit with a connector and hose. This is an advantage in terms of cleaning or when environmental factors are important.

**B**  
 Tie Rod Pneumatic  
 Cylinders

Series  
 4MA

Series  
 4MAJ

Option  
 ACVB

Option  
 LPS0

Series  
 P1D

Series  
 P1F

Series  
 2MNR

**Material specification, piston rod locking**

	<b>Dynamic Rod Lock Unit</b>
Housing	Anodized aluminum
Carriage	-
Lock collars	Hardened steel
Springs	Stainless steel
Bore sizes 32-40 mm	UHMWPE plastic
Bore sizes 50-125 mm	Polyurethane PUR
O Rings	Nitrile rubber NBR
Scraper ring	Polyurethane PUR
Air filter	Brass / Sintered bronze

**Note!**

If a rod guidance module is to be fitted to the brake and the cylinder, as the piston rod extension (WH dimension) is not in accordance with the ISO standard, the piston rod must be extended to provide the same WH dimension as for the cylinder itself. Cylinder piston rod material must be made in steel or stainless steel chromium plated.

**Technical data**

Working pressure:	Max 10 bar
Working media:	Dry filtered compressed air
Working temperature:	-20 to +80°C
Release pressure 1):	Min 4 bar +/- 10%

1) Signal pressure to inlet port of lock unit

**Static lock forces**

<b>Cylinder Bore [mm]</b>	<b>Lock force [N] dyn. Rod Lock</b>
Ø32	550
Ø40	860
Ø50	1345
Ø63	2140
Ø80	3450
Ø100	5390
Ø125	8425

**Locking and braking**

The static locking force corresponds to 7 bar pressure. Under certain circumstances, the lock can also be used as a brake for positioning or similar applications. The maximum values set out in the graph must not be exceeded.

**Use as a brake**

The table shows the maximum values for speed and braking mass if the cylinder is used as a brake. The cylinder should not be exposed to additional compressive forces as this significantly reduces the external mass that can be braked. The cylinder does not act as a motor during braking. Heat is generated if the brake is used frequently, and this must be taken into account too.

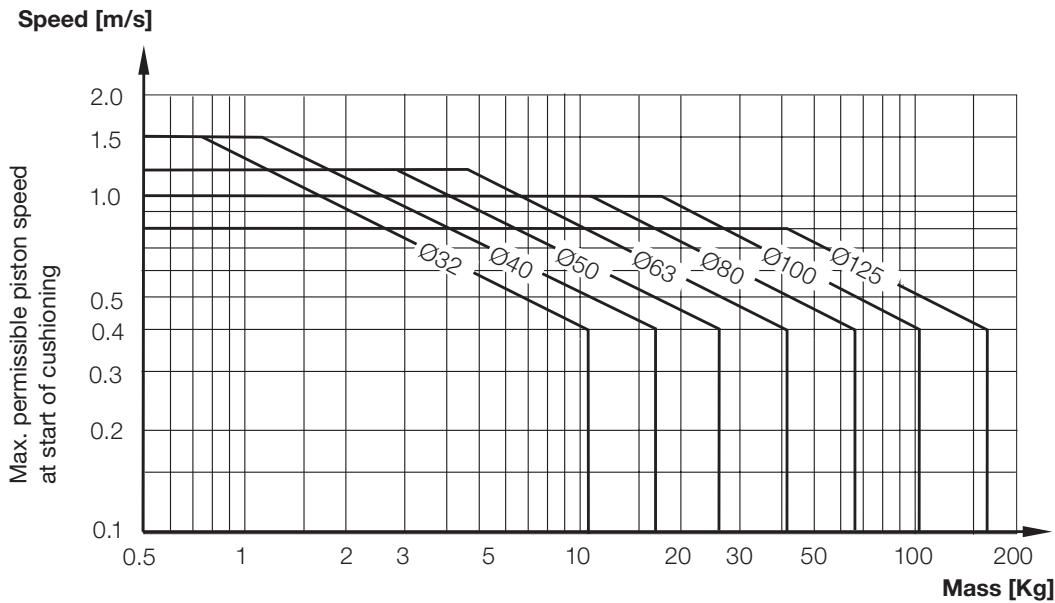

**Cushioning Characteristics**

Air cushion is used to absorb kinetic energy due to load and speed at both end of stroke. This typically consists of a threaded needle screw that adjusts into an orifice in the cylinder end plate. By adjusting the screw further into the orifice you lessen the amount of air that can escape in a given time. Slowing the exhaust of air creates back pressure which slows the piston as it enters into the end cushioning seal. The graph is valid for an horizontal movement and the pressure of 6 bar.

The mass is the sum of internal and external friction, plus any gravitational forces. Work out your expected moving mass and read off the maximum permissible speed at start of cushioning. Alternatively, take your desired speed and expected mass and find the cylinder bore size required.

Please note that piston speed at start of cushioning is typically approx. 50 % higher than the average speed and that it is this higher speed which determines the choice of cylinder.

<b>B</b>
Tie Rod Pneumatic Cylinders
4MA Series
4MAJ Series
ACVB Option
LPSO Option
P1D Series
<b>P1F Series</b>
2MNR Series

**Smooth profile design**

**P1F-S**

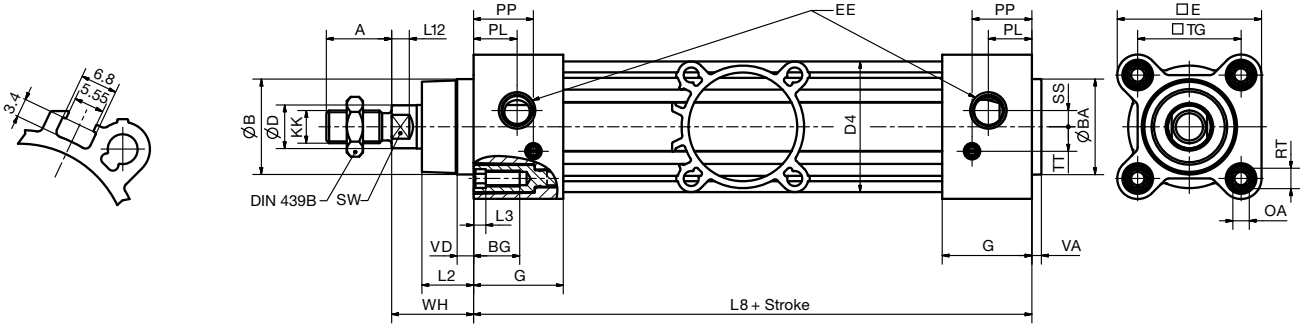

**P1F-K**

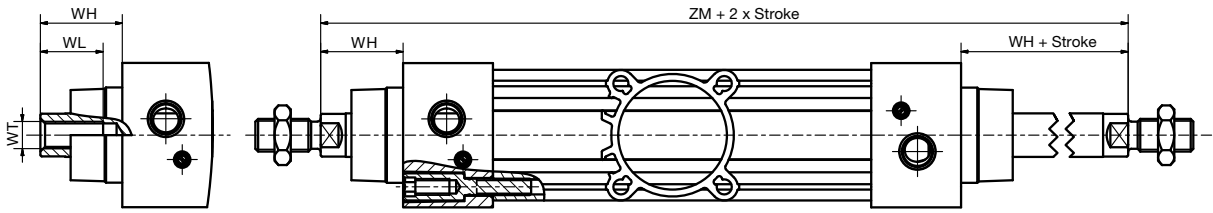

**Tie-rod with round profile design**

**P1F-T**

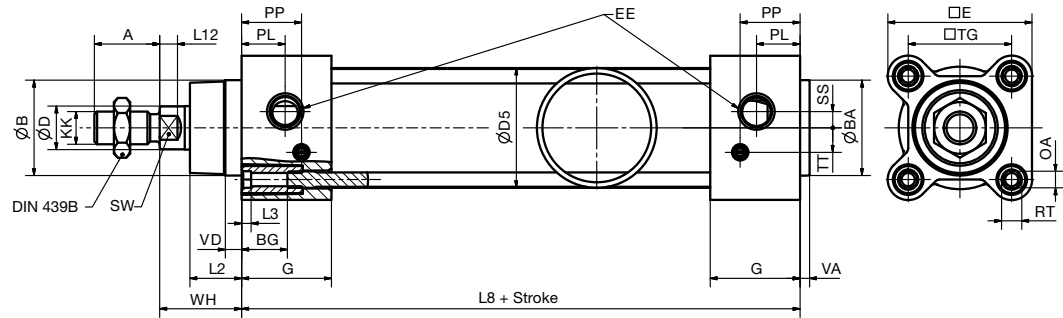

**P1F-N**

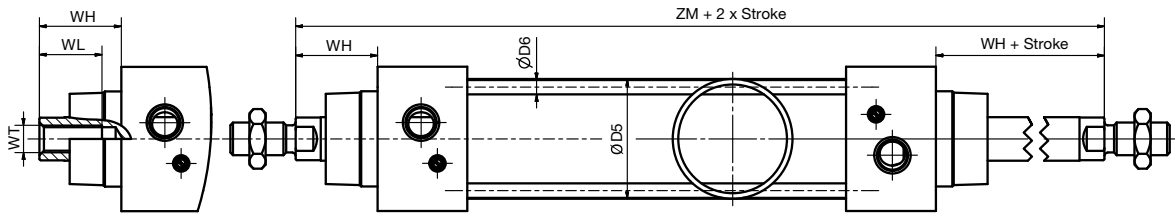

<b>B</b>	Tie Rod Pneumatic Cylinders
	Series
4MA Series	Series
4MAJ Series	Series
ACVB Option	Option
LPS0 Option	Option
P1D Series	Series
P1F Series	Series
2MNR Series	Series

**P1F-S, P1F-K, P1F-T, P1F-N [mm]**

Bore Size	A	ØB d11	ØBA d11	BG	ØD	D4	ØD5	ØD6	E	EE	G	KK	L2	L3	L8
32	22	30	30	17	12	42.5	35	5.3	47	G1/8	28.4	M10x1.25	16.8	4.5	94
40	24	35	35	17	16	48	43	5.3	53	G1/4	33	M12x1.25	19	4.5	105
50	32	40	40	18	20	59.5	54	7.1	64.5	G1/4	33.4	M16x1.5	27.6	4.5	106
63	32	45	45	18	20	69.5	67	7.1	75	G3/8	39.4	M16x1.5	24.3	4.5	121
80	40	45	45	19.5	25	86	85	8.9	94	G3/8	39.4	M20x1.5	30.1	5.5	128
100	40	55	55	19.5	25	103	105	8.9	111	G1/2	44.3	M20x1.5	34	5.5	138
125	54	60	60	20	32	130	130	10.8	136	G1/2	50.8	M27x2	45	0	160

Bore Size	L12	OA	PL	PP	RT	SS	SW	TG	TT	VA	VD	WH	WL	WT	ZM
32	6	6	14	20	M6	5	10	32.5	6.5	3.6	6	26	21	M8x1	146
40	6.5	6	16	22	M6	6	13	38	9	3.5	6	30	23	M10x1.25	165
50	8	8	15.5	21.5	M8	6	17	46.5	9	3.6	6	37	31	M14x1.5	180
63	8	8	18	28	M8	10	17	56.5	11	3.5	6	37	31	M14x1.5	195
80	10	10	20	30	M10	11.5	22	72	14	3.5	6	46	39	M18x1.5	220
100	10	10	18	33	M10	11.5	22	89	14	3.5	6	51	39	M18x1.5	240
125	13	8	20	40	M12	0	27	110	22	5.5	9	65	53	M24x2	290

**Tolerances [mm]**

Bore Size	A	L8	TG	ZM	Stroke Tolerance		
					s ≤ 350 mm	350 mm < s ≤ 600 mm	s > 600 mm
32	0 / - 0.5	± 0.3	± 0.4	-0.4 / + 2.2	+ 1.7	+ 1.9	+ 2.3
40	0 / - 0.5	± 0.3	± 0.4	-0.4 / + 2.2	+ 1.7	+ 1.9	+ 2.3
50	0 / - 0.5	± 0.4	± 0.4	-0.4 / + 2.2	+ 1.8	+ 2	+ 2.4
63	0 / - 0.5	- 0.5 / + 0.3	± 0.4	-0.4 / + 2.2	+ 1.9	+ 2.1	+ 2.5
80	0 / - 0.5	± 0.4	± 0.4	-0.4 / + 2.2	+ 1.9	+ 2.1	+ 2.5
100	0 / - 0.5	± 0.5	± 0.4	-0 / + 2.5	+ 2.0	+ 2.2	+ 2.6
125	0 / - 1.0	± 0.5	± 0.4	-0 / + 2.6	+ 2.1	+ 2.3	+ 2.7

**B**

Tie Rod Pneumatic Cylinders

4MA Series

4MAJ Series

ACVB Option

LPSO Option

P1D Series

P1F Series

2MNR Series



For inventory, lead times, and kit lookup, visit [www.pdnplu.com](http://www.pdnplu.com)

B127

**Parker Hannifin Corporation**  
 Pneumatic Division  
 Wadsworth, Ohio  
[www.parker.com/pneumatics](http://www.parker.com/pneumatics)



**Dynamic rod lock with smooth profile design**

**P1F-L**

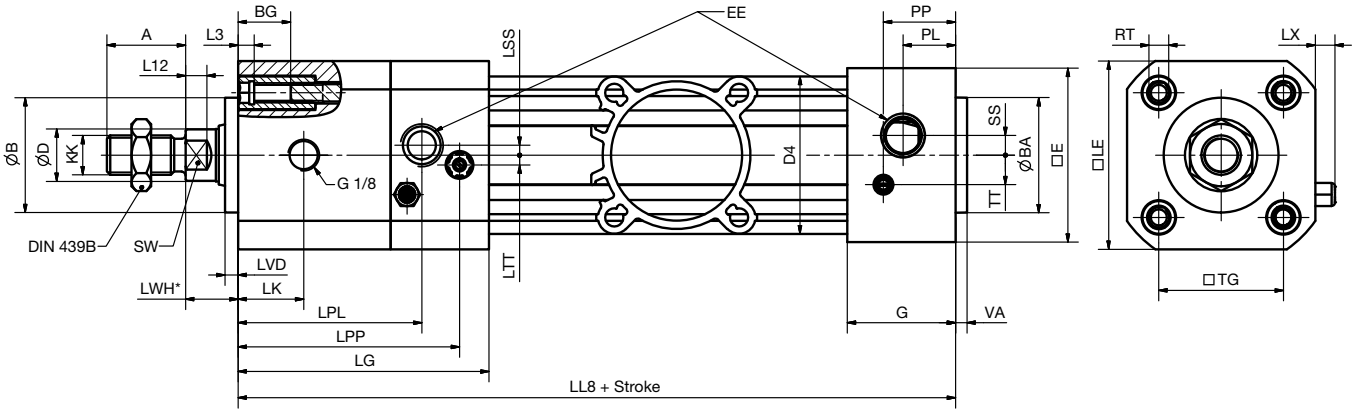

\* Not ISO

**Air reservoir with smooth profile design**

**P1F-P**

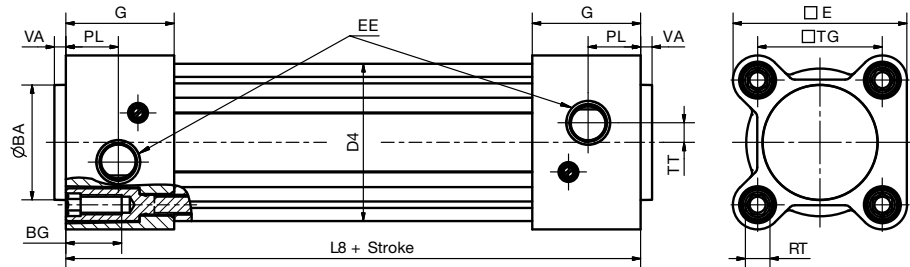

**Important**

Pressure Equipment Directive. According (PED) to the directive 2014/68/EU, for uncertified pressure vessels:  
**Max Working pressure x Volume maximized to 50 Bar x liter, i.e. max 10 bar and 5 liter volume.**  
 In accordance we therefore maximized the volume to max 5 liter cylinder.

<b>B</b>	Tie Rod Pneumatic Cylinders
	4MA Series
	4MAJ Series
	ACVB Option
	LPS0 Option
	P1D Series
	P1F Series
	2MNR Series

**P1F-L, P1F-P [mm]**

Bore Size	A	ØB d11	ØBA d11	BG	ØD	D4	E	EE	G	KK	L3	L8	L12	PL	PP	RT
32	22	30	30	17	12	42.5	47	G1/8	28.4	M10x1.25	4.5	94	6	14	20	M6
40	24	35	35	17	16	48	53	G1/4	33	M12x1.25	4.5	105	6.5	16	22	M6
50	32	40	40	18	20	59.5	64.5	G1/4	33.4	M16x1.5	4.5	106	8	15.5	21.5	M8
63	32	45	45	18	20	69.5	75	G3/8	39.4	M16x1.5	4.5	121	8	18	28	M8
80	40	45	45	19.5	25	86	94	G3/8	39.4	M20x1.5	5.5	128	10	20	30	M10
100	40	55	55	19.5	25	103	111	G1/2	44.3	M20x1.5	5.5	138	10	18	33	M10
125	54	60	60	20	32	130	136	G1/2	50.8	M27x2	0	160	13	20	40	M12

Bore Size	SS	SW	TG	TT	VA	LE	LG	LK	LL8	LPL	LPP	LSS	LTT	LVD	LWH	LX
32	5	10	32.5	6.5	3.6	50	71	18.5	137	53	63	3	4.5	4	15	6
40	6	13	38	9	3.5	57.4	76.5	20	149	56	67.5	3	3	4	16	6
50	6	17	46.5	9	3.6	70	80	21	153	65	71	8	5.5	4	17	7
63	10	17	56.5	11	3.5	82.4	96	30	178	76.5	87	8.5	3	4	17	7
80	11.5	22	72	14	3.5	100	110	35	199	89	101	9	6	4	20	7
100	11.5	22	89	14	3.5	116	132	54	226	112	122	12	6	4	20	7
125	0	27	110	22	5.5	139	144.5	65.5	254	124.5	134.5	14	6	6	27	7

**Tolerances [mm]**

Bore Size	A	L8	TG	Stroke Tolerance		
				s ≤ 350 mm	350 mm < s ≤ 600 mm	s > 600 mm
32	0/-0.5	± 0.3	±0.4	+ 1.7	+ 1.9	+ 2.3
40	0/-0.5	± 0.3	±0.4	+ 1.7	+ 1.9	+ 2.3
50	0/-0.5	- 0.3 / + 0.5	±0.4	+ 1.8	+ 2	+ 2.4
63	0/-0.5	- 0.6 / + 0.2	±0.4	+ 1.9	+ 2.1	+ 2.5
80	0/-0.5	± 0.4	±0.4	+ 1.9	+ 2.1	+ 2.5
100	0/-0.5	± 0.5	±0.4	+ 2.0	+ 2.2	+ 2.6
125	0/-1.0	± 0.5	±0.4	+ 2.1	+ 2.3	+ 2.7

**P1F-P**

Bore Size Ø	Air Volume Base 0 mm [cm³]	Air Volume Per Stroke of [cm³/100 mm]
32	40	80
40	68	126
50	91	196
63	137	312
80	289	503
100	417	785
125	809	1227

**B**

Tie Rod Pneumatic Cylinders

4MA Series

4MAJ Series

ACVB Option

LPSO Option

P1D Series

P1F Series

2MNR Series



For inventory, lead times, and kit lookup, visit [www.pdnplu.com](http://www.pdnplu.com)

**Mountings**

Flange MF1 / MF2 ①    Foot brackets MS1 ②    Pivot bracket with rigid bearing AB7 ③    Swivel eye bracket MP6 ④    Clevis bracket MP2 ⑤

Bore Size mm	Flange MF1 / MF2 ①	Foot brackets MS1 ②	Pivot bracket with rigid bearing AB7 ③	Swivel eye bracket MP6 ④	Clevis bracket MP2 ⑤
32	P1C-4KMB	P1C-4KMF	P1C-4KMDB	P1C-4KMSB	P1C-4KMTB
40	P1C-4LMB	P1C-4LMF	P1C-4LMDB	P1C-4LMSB	P1C-4LMTB
50	P1C-4MMB	P1C-4MMF	P1C-4MMDB	P1C-4MMSB	P1C-4MMTB
63	P1C-4NMB	P1C-4NMF	P1C-4NMDB	P1C-4NMSB	P1C-4NMTB
80	P1C-4PMB	P1C-4PMF	P1C-4PMDB	P1C-4PMSB	P1C-4PMTB
100	P1C-4QMB	P1C-4QMF	P1C-4QMDB	P1C-4QMSB	P1C-4QMTB
125	P1C-4RMB	P1C-4RMF	P1C-4RMDB	P1C-4RMSB	P1C-4RMTB

Clevis bracket MP4 ⑥    Clevis bracket AB6 ⑦    Pivot bracket with swivel bearing CS7 ⑧    3 and 4 position flange JP1 ⑨    Pivot brackets AT4 ⑩

Bore Size mm	Clevis bracket MP4 ⑥	Clevis bracket AB6 ⑦	Pivot bracket with swivel bearing CS7 ⑧	3 and 4 position flange JP1 ⑨	Pivot brackets AT4 ⑩
32	P1C-4KMEB	P1C-4KMCB	P1C-4KMAF	P1E-6KB0	9301054261
40	P1C-4LMEB	P1C-4LMCB	P1C-4LMAF	P1E-6LB0	9301054262
50	P1C-4MMEB	P1C-4MMCB	P1C-4MMAF	P1E-6MB0	9301054262
63	P1C-4NMEB	P1C-4NMCB	P1C-4NMAF	P1E-6NB0	9301054264
80	P1C-4PMEB	P1C-4PMCB	P1C-4PMAF	P1E-6PB0	9301054264
100	P1C-4QMEB	P1C-4QMCB	P1C-4QMAF	P1E-6QB0	9301054266
125	P1C-4RMEB	P1C-4RMCB	P1C-4RMAF	—	9301054266

Flange trunnion MT5/MT6 ⑪    Intermediate trunnion MT4 ⑫    Swivel rod eye AP6 ⑬    Clevis AP2 ⑭    Flexo coupling PM5 ⑮

Bore Size mm	Flange trunnion MT5/MT6 ⑪	Intermediate trunnion MT4 ⑫	Swivel rod eye AP6 ⑬	Clevis AP2 ⑭	Flexo coupling PM5 ⑮
32	P1D-4KMYF	refer to page 138	P1C-4KRS	P1C-4KRC    P1S-4JRD	P1C-4KRF
40	P1D-4LMYF	refer to page 138	P1C-4LRS	P1C-4LRC    P1S-4LRD	P1C-4LRF
50	P1D-4MMYF	refer to page 138	P1C-4MRS	P1C-4MRC    P1S-4MRD	P1C-4MRF
63	P1D-4NMYF	refer to page 138	P1C-4MRS	P1C-4MRC    P1S-4MRD	P1C-4MRF
80	P1D-4PMYF	refer to page 138	P1C-4PRS	P1C-4PRC    P1S-4PRD	P1C-4PRF
100	P1D-4QMYF	refer to page 138	P1C-4PRS	P1C-4PRC    P1S-4PRD	P1C-4PRF
125	—	refer to page 138	P1C-4RRS	P1C-4RRC    P1S-4RRD	P1C-4RRF

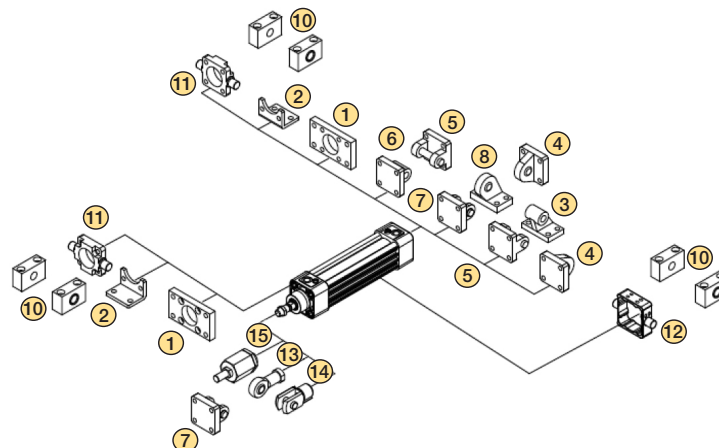

**B**  
 Tie Rod Pneumatic Cylinders  
 4MA Series  
 4MAJ Series  
 ACVB Option  
 LPSO Option  
 P1D Series  
 P1F Series  
 2MNR Series



For inventory, lead times, and kit lookup, visit [www.pdnplu.com](http://www.pdnplu.com)

B130

Parker Hannifin Corporation  
 Pneumatic Division  
 Wadsworth, Ohio  
[www.parker.com/pneumatics](http://www.parker.com/pneumatics)

**Flange - MF1 / MF2**



Intended for fixed mounting of cylinder.  
 Flange can be fitted to front or rear end cover of cylinder.

**Materials:**

Flange: Surface-treated steel  
 Mounting screws acc. to DIN 6912:  
 Zinc-plated steel 8.8  
 Supplied complete with mounting screws for attachment to the cylinder.

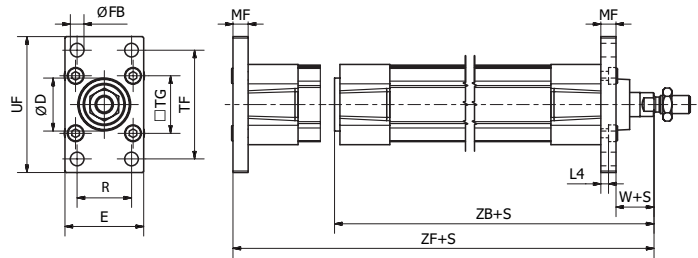

**According to ISO 15552**

Bore Size mm	D (H11) mm	E mm	ØFB (H13) mm	L4 mm	MF mm	R mm	TF mm	TG mm	UF mm	W* mm	ZB* mm	ZF* mm	Weight kg	Part Number
32	30	45	7	5.0	10	32	64	32.5	80	16	123.5	130	0.21	<b>P1C-4KMB</b>
40	35	52	9	5.0	10	36	72	38.0	90	20	138.5	145	0.27	<b>P1C-4LMB</b>
50	40	65	9	6.5	12	45	90	46.5	110	25	146.5	155	0.53	<b>P1C-4MMB</b>
63	45	75	9	6.5	12	50	100	56.5	120	25	161.5	170	0.66	<b>P1C-4NMB</b>
80	45	95	12	9.0	16	63	126	72.0	150	30	177.5	190	1.45	<b>P1C-4PMB</b>
100	55	115	14	9.0	16	75	150	89.0	170	35	192.5	205	1.60	<b>P1C-4QMB</b>
125	60	140	16	10.5	20	90	180	110.0	205	45	230.5	245	3.34	<b>P1C-4RMB</b>

\*Does not apply to cylinders with piston rod extension or lock units.

**Foot Bracket - MS1**



Intended for fixed mounting of cylinder.  
 Foot bracket can be fitted to front or rear end cover of the cylinder.

**Materials:**

Flange: Surface-treated steel  
 Mounting screws acc. to DIN 6912:  
 Zinc-plated steel 8.8:

Supplied complete with mounting screws for attachment to the cylinder.

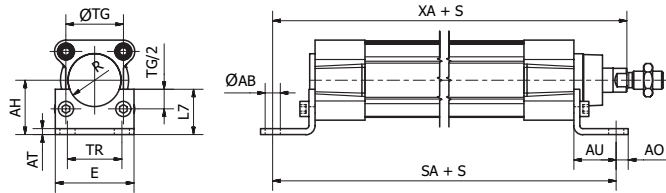

**According to ISO 15552**

Bore Size mm	ØAB (H14) mm	AH (JS15) mm	AO mm	AT mm	AU mm	E mm	L7 mm	R mm	SA* mm	TG mm	TR (JS14) mm	XA* mm	Weight ** kg	Part Number
32	7.0	32	11	4	24	45	30	15.0	142	32.5	32	144	0.08	<b>P1C-4KMF</b>
40	10.0	36	8	4	28	52	30	17.5	161	38.0	36	163	0.09	<b>P1C-4LMF</b>
50	10.0	45	15	5	32	65	36	20.0	170	46.5	45	175	0.18	<b>P1C-4MMF</b>
63	10.0	50	13	5	32	75	35	22.5	185	56.5	50	190	0.20	<b>P1C-4NMF</b>
80	12.0	63	14	6	41	95	47	22.5	210	72.0	63	215	0.40	<b>P1C-4PMF</b>
100	14.5	71	16	6	41	115	53	27.5	220	89.0	75	230	0.54	<b>P1C-4QMF</b>
125	16.5	90	25	8	45	140	70	30.0	250	110.0	90	270	1.10	<b>P1C-4RMF</b>

\*Does not apply to cylinders with piston rod extension or lock units.

\*\* per bracket

**B**

Tie Rod Pneumatic Cylinders

4MA Series

4MAJ Series

ACVB Option

LPSO Option

P1D Series

P1F Series

2MNR Series



**Pivot Bracket with Rigid Bearing - AB7**



Intended for flexible mounting of cylinder. The pivot bracket can be combined with clevis bracket MP2.

**Materials:**  
Pivot bracket: Aluminum  
Bush: Steel and PTFE

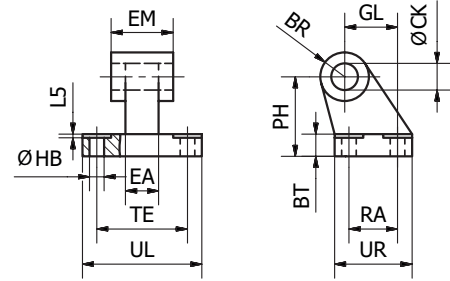

**According to ISO 15552**

Bore Size mm	CK mm	HB mm	L5 mm	TE mm	UL mm	GL mm	RA mm	EA mm	EM mm	UR mm	PH mm	BT mm	BR mm	Weight kg	Part Number
32	10	6.6	1.6	38	51	21	18	10	26	31	32	8	10.0	0.05	<b>P1C-4KMDB</b>
40	12	6.6	1.6	41	54	24	22	15	28	35	36	10	11.0	0.09	<b>P1C-4LMDB</b>
50	12	9.0	1.6	50	65	33	30	16	32	45	45	12	13.0	0.16	<b>P1C-4MMDB</b>
63	16	9.0	1.6	52	67	37	35	16	40	50	50	14	15.0	0.20	<b>P1C-4NMDB</b>
80	16	11.0	2.5	66	86	47	40	20	50	60	63	14	15.0	0.32	<b>P1C-4PMDB</b>
100	20	11.0	2.5	76	96	55	50	20	60	70	71	17	19.0	0.53	<b>P1C-4QMDB</b>
125	25	14.0	3.2	94	124	70	60	30	70	90	90	20	22.5	1.01	<b>P1C-4RMDB</b>

**Swivel Eye Bracket - MP6**



Intended for use together with clevis bracket AB6.

**Materials:**  
Bracket: Aluminum  
Swivel bearing acc. to DIN 648K:  
Hardened steel

Supplied complete with mounting screws for attachment to cylinder.

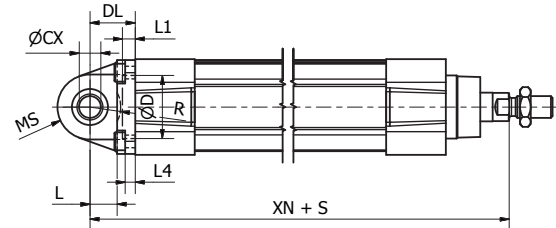
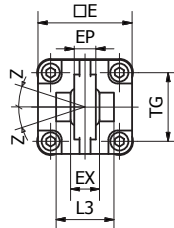

**According to ISO 15552**

Bore Size mm	CX mm	D mm	DL mm	E mm	EP mm	EX mm	L mm	L1 mm	L3 mm	L4 mm	MS mm	R mm	TG mm	XN* mm	Z mm	Weight kg	Part Number
32	10	30	22	45	10.5	14	12	7	-	5.5	16	-	32.5	142	4°	0.09	<b>P1C-4KMSB</b>
40	12	35	25	52	12	16	15	7	-	5.5	18	-	38	160	4°	0.13	<b>P1C-4LMSB</b>
50	16	40	27	65	15	21	15	7	51	6.5	21	19	46.5	170	4°	0.24	<b>P1C-4MMSB</b>
63	16	45	32	75	15	21	20	7	-	6.5	23	-	56.5	190	4°	0.29	<b>P1C-4NMSB</b>
80	20	45	36	95	18	25	20	9	74	10	28	24	72	210	4°	0.59	<b>P1C-4PMSB</b>
100	20	55	41	115	18	25	25	9	140	10	30	32	89	230	4°	0.78	<b>P1C-4QMSB</b>
125	30	60	50	140	25	37	30	9	-	10	40	-	110	275	4°	1.38	<b>P1C-4RMSB</b>

\*Does not apply to cylinders with piston rod extension or lock units.

**B**  
 Tie Rod Pneumatic Cylinders  
 Series 4MA  
 Series 4MAJ  
 Option ACVB  
 Option LPSO  
 Series P1D  
 Series P1F  
 Series 2MNR



For inventory, lead times, and kit lookup, visit [www.pdnplu.com](http://www.pdnplu.com)

**Clevis Bracket - MP2**



Intended for flexible mounting of cylinder.  
 Can be combined with clevis bracket MP4  
 and pivot bracket with rigid bearing AB7.

**Materials:**

- Clevis bracket: Aluminum
- Pin: Surface hardened steel
- Locking pin: Spring steel
- Circlips according to DIN 471:
- Spring steel
- Mounting screws acc. to DIN 912:
- Zinc-plated steel 8.8

Supplied complete with mounting screws  
 for attachment to the cylinder.

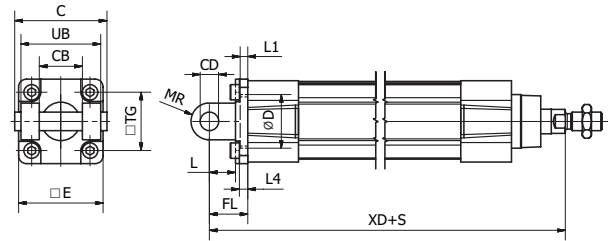

**According to ISO 15552**

Bore Size mm	C mm	E mm	UB mm	CB mm	TG mm	FL mm	L1 mm	L mm	L4 mm	D mm	CD mm	MR mm	XD* mm	Weight kg	Part Number
32	53	45	45	26	32.5	22	5	13	5.5	30	10	10	142	0.08	<b>P1C-4KMTB</b>
40	60	52	52	28	38	25	5	16	5.5	35	12	12	160	0.10	<b>P1C-4LMTB</b>
50	68	65	60	32	46.5	27	5	16	6.5	40	12	12	170	0.18	<b>P1C-4MMTB</b>
63	78	75	70	40	56.5	32	5	21	6.5	45	16	16	190	0.24	<b>P1C-4NMTB</b>
80	98	95	90	50	72	36	5	22	10	45	16	16	210	0.49	<b>P1C-4PMTB</b>
100	118	115	110	60	89	41	5	27	10	55	20	20	230	0.73	<b>P1C-4QMTB</b>
125	139	140	130	70	110	50	7	30	10	60	25	25	275	1.37	<b>P1C-4RMTB</b>

\*Does not apply to cylinders with piston rod extension or lock units.

**Clevis Bracket - MP4**



Intended for flexible mounting of cylinder. Clevis bracket MP4  
 can be combined with clevis  
 bracket MP2.

**Materials:**

- Clevis bracket: Aluminum
- Bush: Steel and PTFE
- Mounting screws acc. to DIN 912:
- Zinc-plated steel 8.8

Supplied complete with mounting screws  
 for attachment to the cylinder.

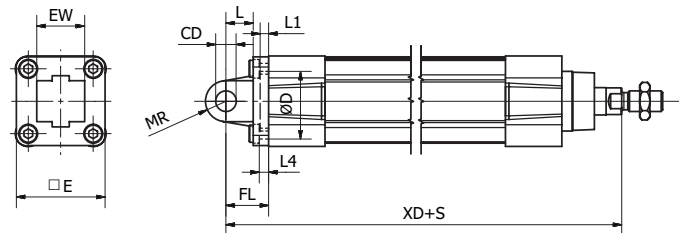

**According to ISO 15552**

Bore Size mm	CD mm	D mm	E mm	EW mm	FL mm	L mm	L1 mm	L4 mm	MR mm	TG mm	XD* mm	Weight kg	Part Number
32	10	30	47	26	22	12	6.5	6	10.5	32.5	142	0.08	<b>P1C-4KMEB</b>
40	12	35	52	28	25	16	5	5.5	12	38	160	0.11	<b>P1C-4LMEB</b>
50	12	40	65	32	27	16	5	6.5	12	46.5	170	0.18	<b>P1C-4MMEB</b>
63	16	45	78	40	32	21	5	6.5	16	56.5	190	0.28	<b>P1C-4NMEB</b>
80	16	45	95	50	36	22	5	10	16	72	210	0.52	<b>P1C-4PMEB</b>
100	20	55	115	60	41	27	5	10	20	89	230	0.79	<b>P1C-4QMEB</b>
125	25	60	140	70	50	30	7	10	25	110	275	1.46	<b>P1C-4RMEB</b>

\*Does not apply to cylinders with piston rod extension or lock units.

**B**

Tie Rod Pneumatic  
 Cylinders

4MA  
 Series

4MAJ  
 Series

ACVB  
 Option

LPSO  
 Option

P1D  
 Series

P1F  
 Series

2MNR  
 Series



For inventory, lead times, and kit  
 lookup, visit [www.pdnplu.com](http://www.pdnplu.com)

B133

**Parker Hannifin Corporation**  
 Pneumatic Division  
 Wadsworth, Ohio  
[www.parker.com/pneumatics](http://www.parker.com/pneumatics)

**Clevis Bracket - AB6**

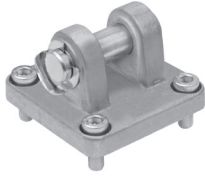

Intended for flexible mounting of cylinder.  
 Clevis bracket AB6 can be combined with pivot brackets MP6 and CS7 or swivel rod eye AP6.

**Materials:**

Clevis bracket: Aluminum  
 Pin: Surface hardened steel  
 Locking pin: Spring steel  
 Circlips according to DIN 471: Spring steel  
 Mounting screws acc. to DIN 912: Zinc-plated steel 8.8  
 Supplied complete with mounting screws for attachment to the cylinder.

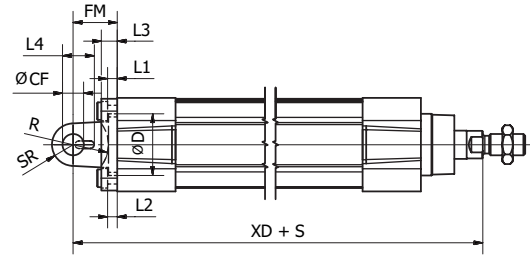
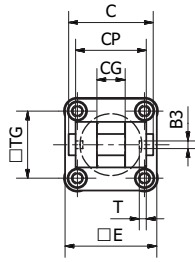

**According to ISO 15552**

Bore Size mm	B3 mm	C mm	CF mm	CG mm	CP mm	D mm	E mm	FM mm	I2 mm	T mm	R mm	L1 mm	L4 mm	L3 mm	SR mm	TG mm	XD* mm	Weight kg	Part Number
32	3.3	41	10	14	34	30	45	22	5.5	3	17	5	16.5	9	10	32.5	142	0.04	<b>P1C-4KMCB</b>
40	4.3	48	12	16	40	35	52	25	5.5	4	20	5	18	9	12	38	160	0.07	<b>P1C-4LMCB</b>
50	4.3	54	16	21	45	40	65	27	6.5	4	22	5	22	11	14	46.5	170	0.11	<b>P1C-4MMCB</b>
63	4.3	60	16	21	51	45	75	32	6.5	4	25	5	22	11	18	56.5	190	0.19	<b>P1C-4NMCB</b>
80	4.3	75	20	25	65	45	95	36	10.0	4	30	5	26	14	20	72	210	0.38	<b>P1C-4PMCB</b>
100	6.3	85	20	25	75	55	115	41	10.0	4	32	5	26	14	22	89	230	0.61	<b>P1C-4QMCB</b>
125	6.3	110	30	37	97	60	140	50	10.0	6	42	7	39	20	25	110	275	1.10	<b>P1C-4RMCB</b>

\*Does not apply to cylinders with piston rod extension or lock units.

**Pivot Bracket with Swivel Bearing - CS7**



Intended for use together with clevis bracket AB6.

**Materials:**

Pivot bracket: Aluminum  
 Swivel bearing acc. to DIN 648K:  
 Hardened steel

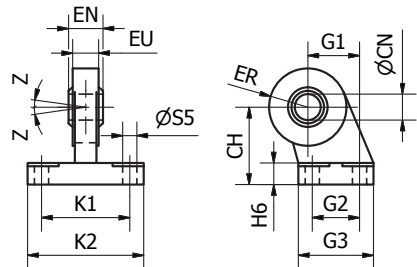

**According to ISO 15552**

Bore Size mm	CN mm	S5 mm	K1 mm	K2 mm	EU mm	G1 mm	G2 mm	EN mm	G3 mm	CH mm	H6 mm	ER mm	Z mm	Weight kg	Part Number
32	10	6.6	38	51	10.5	21	18	14	31	32	10	15	4°	0.18	<b>P1C-4KMAF</b>
40	12	6.6	41	54	12.0	24	22	16	35	36	10	18	4°	0.27	<b>P1C-4LMAF</b>
50	16	9.0	50	65	15.0	33	30	21	45	45	12	20	4°	0.46	<b>P1C-4MMAF</b>
63	16	9.0	52	67	15.0	37	35	21	50	50	12	23	4°	0.55	<b>P1C-4NMAF</b>
80	20	11.0	66	86	18.0	47	40	25	60	63	14	27	4°	0.97	<b>P1C-4PMAF</b>
100	20	11.0	76	96	18.0	55	50	25	70	71	15	30	4°	1.33	<b>P1C-4QMAF</b>
125	30	13.5	94	124	25.0	70	60	37	90	90	20	40	4°	3.00	<b>P1C-4RMAF</b>



For inventory, lead times, and kit lookup, visit [www.pdnplu.com](http://www.pdnplu.com)



**3 and 4 Position Flange - JP1**



Mounting kit for back to back mounted cylinders, 3 and 4 position cylinders.

**Materials:**  
 Mounting: Aluminum  
 Mounting screws: Zinc-plated steel 8.8

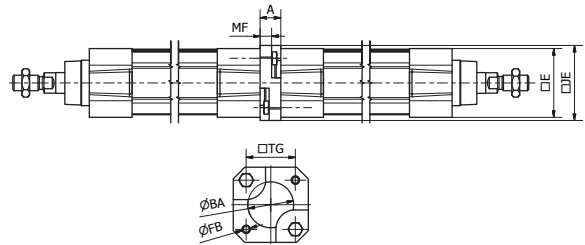

Bore Size mm	A mm	ØBA mm	E mm	ØFB mm	JE mm	MF mm	TG mm	Weight kg	Part Number
32	16	30	47	6.5	50	9	32.5	0.04	<b>P1E-6KB0</b>
40	16	35.5	53	6.5	58	9	38.0	0.07	<b>P1E-6LB0</b>
50	20	40.5	64.5	8.5	66	6	46.5	0.08	<b>P1E-6MB0</b>
63	20	45.5	75	8.5	80	6	56.5	0.16	<b>P1E-6NB0</b>
80	25	45.5	94	10.5	99	8	72.0	0.30	<b>P1E-6PB0</b>
100	25	55.5	111	10.5	118	8	89.0	0.54	<b>P1E-6QB0</b>

**Pivot Brackets for MT Trunnion - AT4**



Intended for use together with trunnion MT4.

**Materials:**  
 Pivot bracket: Surface-treated aluminum  
 Bush: Bronze  
 Supplied in pairs

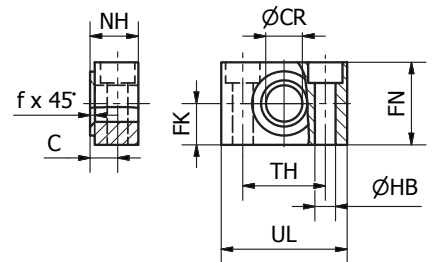

**According to ISO 1552**

Bore Size mm	UL mm	NH mm	TH mm	C mm	CR mm	HB mm	FN mm	FK mm	fx45° mm	Weight kg	Part Number
32	46	18	32	10.5	12	6.6	30	15	1.0	0.08	<b>9301054261</b>
40	55	21	36	12.0	16	9	36	18	1.6	0.14	<b>9301054262</b>
50	55	21	36	12.0	16	9	36	18	1.6	0.14	<b>9301054262</b>
63	65	23	42	13.0	20	11	40	20	1.6	0.21	<b>9301054264</b>
80	65	23	42	13.0	20	11	40	20	1.6	0.21	<b>9301054264</b>
100	75	28.5	50	16.0	25	14	50	25	2.0	0.36	<b>9301054266</b>
125	75	28.5	50	16.0	25	14	50	25	2.0	0.36	<b>9301054266</b>

**B**

Tie Rod Pneumatic Cylinders

4MA Series

4MAJ Series

ACVB Option

LPSO Option

P1D Series

P1F Series

2MNR Series



**Flange Trunnion - MT5 / MT6**



Intended for articulated mounting of cylinder. This trunnion can be flange mounted on the front or rear end cover of the cylinder.

**Materials:**

Trunnion: Zinc-plated steel  
 Screws: Zinc-plated steel 8.8  
 Delivered complete with mounting screws for attachment to the cylinder.

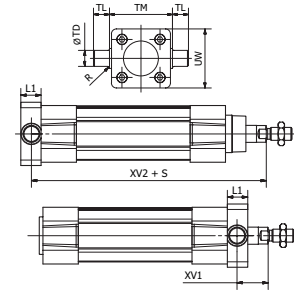

**According to ISO 15552**

Bore Size mm	L1 mm	R mm	TD (e9) mm	TL (h14) mm	TM (h14) mm	UW mm	XV1* mm	XV2* mm	Weight kg	Part Number
32	14	1.0	12	12	50	46	19.5	127.0	0.14	<b>P1D-4KMYF</b>
40	19	1.6	16	16	63	59	21.0	144.5	0.39	<b>P1D-4LMYF</b>
50	19	1.6	16	16	75	69	28.0	152.5	0.51	<b>P1D-4MMYF</b>
63	24	1.6	20	20	90	84	25.5	170.0	1.04	<b>P1D-4NMYF</b>
80	24	1.6	20	20	110	102	34.5	186.0	1.57	<b>P1D-4PMYF</b>
100	29	2.0	25	25	132	125	37.0	203.5	3.00	<b>P1D-4QMYF</b>

\* Does not apply to cylinders with piston rod extension or lock units.  
 To fit a flange mounted trunnion at the front end cover of a cylinder with lock unit, the piston rod must be extended. This is in order to provide the same WH dimensions as for the P1F base cylinder.

**Center Trunnion - MT4**



Available for P1F Profile and Tie-rod versions the MT4 center trunnion when combined with AT4 pivot brackets is intended for articulated mounting of the cylinder. The trunnion is free so that it can be fixed afterward when the cylinder is at the right place on the machine.

**Material:** Zinc plated steel

Refer to the model code page B95 for ordering cylinder with trunnion.

Important note: the rear end cylinder cover needs to be removed for adding the trunnion when ordered as a single kit.

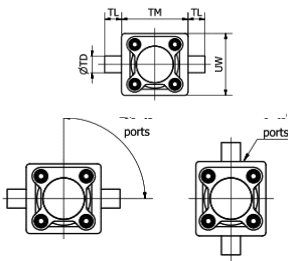
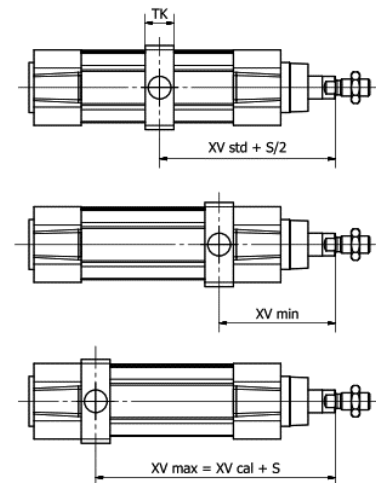

According to ISO 15552					P1F-S/K		P1F-T/N		P1F-L	P1F-H	Part Number				
Bore Size mm	TL h14 mm	TM h14 mm	ØTD e9 mm	XV* std mm	TK mm	UW mm	XV* min mm	XV* cal mm	TK mm	UW mm	XV* min mm	XV* cal mm	Adder to XV*	Smooth Profile	Tie-rod
32	12	50	12	73	18	52	65	81	15	46	63	83	32	48	<b>P1F-4KMY</b> <b>P1F-4KMYT</b>
40	16	63	16	83	20	60	74	91	20	59	74	91	30	55	<b>P1F-4LMY</b> <b>P1F-4LMYT</b>
50	16	75	16	90	20	71	82	98	20	69	82	98	29	70	<b>P1F-4MMY</b> <b>P1F-4MMYT</b>
63	20	90	20	98	26	84	91	104	25	84	90	105	39	70	<b>P1F-4NMY</b> <b>P1F-4NMYT</b>
80	20	110	20	110	26	105	100	120	25	102	99	121	45	90	<b>P1F-4PMY</b> <b>P1F-4PMYT</b>
100	25	132	25	120	32	129	113	127	30	125	112	128	57	92	<b>P1F-4QMY</b> <b>P1F-4QMYT</b>
125	25	160	25	145	33	154	134	156	33	155	134	156	56	122	<b>P1F-4RMY</b> <b>P1F-4RMYT</b>

\*Does not apply to cylinders with piston rod extension or lock units.



For inventory, lead times, and kit lookup, visit [www.pdnplu.com](http://www.pdnplu.com)

Swivel Rod Eye - AP6



Swivel rod eye for articulated mounting of the cylinder. Swivel rod eye can be combined with clevis bracket AB6.

**Materials:**

Swivel rod eye: Zinc-plated steel  
Swivel bearing according to DIN 648K: hardened steel

Swivel rod eye: Stainless steel  
Swivel bearing according to DIN 648K: Hardened steel

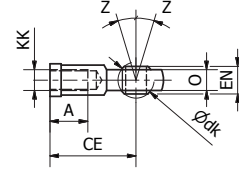
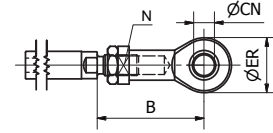

According to ISO 8139

Bore Size mm	A mm	B min mm	B max mm	CE mm	CN mm	EN mm	ER mm	KK	LE dk	N mm	O mm	Z	Weight kg	Part Number	
														Galvanized Steel	Stainless Steel
32	15	48.0	55	43	10	14	29	M10x1.25	19.0	17	10.5	13°	0.07	<b>P1C-4KRS</b>	<b>P1S-4JRT</b>
40	18	56.0	62	50	12	16	33	M12x1.25	22.2	19	12.0	13°	0.11	<b>P1C-4LRS</b>	<b>P1S-4LRT</b>
50	24	72.0	80	64	16	21	43	M16x1.5	28.5	22	15.0	15°	0.21	<b>P1C-4MRS</b>	<b>P1S-4MRT</b>
63	24	72.0	80	64	16	21	43	M16x1.5	28.5	22	15.0	15°	0.21	<b>P1C-4MRS</b>	<b>P1S-4MRT</b>
80	30	87.0	97	77	20	25	51	M20x1.5	34.9	30	18.0	15°	0.38	<b>P1C-4PRS</b>	<b>P1S-4PRT</b>
100	30	87.0	97	77	20	25	51	M20x1.5	34.9	30	18.0	15°	0.38	<b>P1C-4PRS</b>	<b>P1S-4PRT</b>
125	45	123.5	137	110	30	37	70	M27x2	50.8	41	25.0	15°	1.15	<b>P1C-4RRS</b>	<b>P1S-4RRT</b>

Clevis - AP2

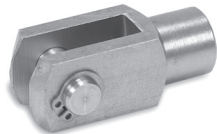

Stainless steel



Galvanized steel

Clevis for articulated mounting of the cylinder.

**Materials:**

Clevis, clip: Zinc-plated steel  
Pin: Hardened steel

Clevis, clip: Stainless steel  
Pin: Stainless steel

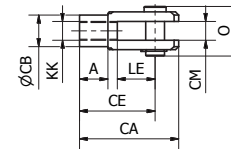
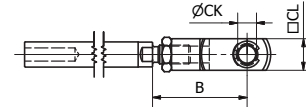

According to ISO 8140

Bore Size mm	A mm	B min mm	B max mm	CA mm	CB mm	CE mm	CK mm	CL mm	CM mm	KK	LE mm	O mm	Weight kg	Part Number	
														Galvanized Steel	Stainless Steel
32	15	45	52	52	18	40	10	20	10	M10x1.25	20	25	0.09	<b>P1C-4KRC</b>	<b>P1S-4JRD</b>
40	18	54	60	62	20	48	12	24	12	M12x1.25	24	31	0.15	<b>P1C-4LRC</b>	<b>P1S-4LRD</b>
50	24	72	80	83	26	64	16	32	16	M16x1.5	32	40	0.34	<b>P1C-4MRC</b>	<b>P1S-4MRD</b>
63	24	72	80	83	26	64	16	32	16	M16x1.5	32	40	0.34	<b>P1C-4MRC</b>	<b>P1S-4MRD</b>
80	30	90	100	105	34	80	20	40	20	M20x1.5	40	50	0.67	<b>P1C-4PRC</b>	<b>P1S-4PRD</b>
100	30	90	100	105	34	80	20	40	20	M20x1.5	40	50	0.67	<b>P1C-4PRC</b>	<b>P1S-4PRD</b>
125	40	123.5	137	148	48	110	30	55	30	M27x2.0	54	65	1.80	<b>P1C-4RRC</b>	<b>P1S-4RRD</b>

**B**

Tie Rod Pneumatic Cylinders

4MA Series

4MAJ Series

ACVB Option

LPSO Option

P1D Series

P1F Series

2MNR Series



**Flexo Coupling - PM5**

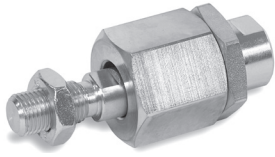

Flexo coupling for articulated mounting of piston rod. Flexo fitting is intended to take up axial angle errors within a range of  $\pm 4^\circ$ .

**Materials:**

Flexo coupling, nut: Zinc-plated steel

Supplied complete with galvanized adjustment nut.

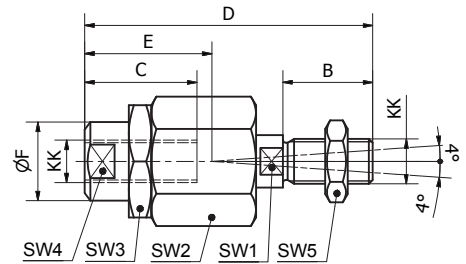

Bore Size mm	KK	B mm	C mm	D mm	E mm	ØF mm	SW1 mm	SW2 mm	SW3 mm	SW4 mm	SW5 mm	Weight kg	Part Number
32	M10x1.25	20	23	70	31	21	12	30	30	19	17	0.23	<b>P1C-4KRF</b>
40	M12x1.25	24	30	77	31	21	12	30	30	19	19	0.23	<b>P1C-4LRF</b>
50	M16x1.5	32	32	108	45	33.5	19	41	41	30	24	0.65	<b>P1C-4MRF</b>
63	M16x1.5	32	32	108	45	33.5	19	41	41	30	24	0.65	<b>P1C-4MRF</b>
80	M20x1.5	40	42	122	56	33.5	19	41	41	30	30	0.71	<b>P1C-4PRF</b>
100	M20x1.5	40	42	122	56	33.5	19	41	41	30	30	0.71	<b>P1C-4PRF</b>
25	M27x2	54	48	147	51	39	24	55	55	32	41	1.60	<b>P1C-4RRF</b>

**Nuts**



Intended for fixed mounting of accessories to the piston rod.

**Material:** Zinc-plated steel

All P1D cylinders are delivered with a zinc-plated steel piston rod nut.

**Stainless Steel Nut**

**Material:** Stainless steel A2

**Acid-proof nut**

**Material:** Acid-proof steel A4

Cylinders with acid-proof piston rod are supplied with nut of acid-proof steel.

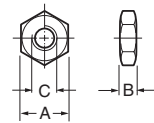

**According to DIN 439 B**

Bore Size mm	A mm	B mm	C	Weight kg	Part Numbers		
					Steel	Stainless Steel	Acid-Proof
32	17	5.0	M10x1.25	0.007	<b>0867340300</b>	<b>9126725404</b>	
40	19	6.0	M12x1.25	0.010	<b>0867340400</b>	<b>9126725405</b>	<b>0261109920</b>
50	24	8.0	M16x1.5	0.021	<b>0867340600</b>	<b>9126725406</b>	<b>0261109917</b>
63	24	8.0	M16x1.5	0.021			
80	30	10.0	M20x1.5	0.040	<b>0261109911</b>	<b>0261109921</b>	<b>0261109916</b>
100	30	10.0	M20x1.5	0.040			
125	41	13.5	M27x2	0.100	<b>0867340900</b>	<b>0261109922</b>	<b>0261109918</b>
160/200	55	18.0	M36x2	C.F.	<b>L075540036</b>	Consult factory	Consult factory

C.F. = Consult Factory

**B**  
 Tie Rod Pneumatic Cylinders  
 4MA Series  
 4MAJ Series  
 ACVB Option  
 LP50 Option  
 P1D Series  
 P1F Series  
 2MNR Series



For inventory, lead times, and kit lookup, visit [www.pdnplu.com](http://www.pdnplu.com)

**Continuous Position Sensing (CPS)**

Analogue signal or IO-Link communication for linear cylinders many applications require more than just end of stroke sensing of an actuator, but traditional methods of continuous sensing are expensive and difficult to implement. Parker's CPS series of the P8S sensor family enables quick, easy, precise, and contactless position sensing of a piston. This can be installed on a standard linear actuator and offers an outstanding price to performance ratio.

**Product Features:**

Continuous position sensing

- IO-Link communication with M12 connector
- No modification to the actuator
- Analog version with M8 connector
- 5 sizes with sensing ranges from 32 mm to 256 mm
- IP67 design suitable for any industrial application
- Yellow teach button for easy set-up

**Technical specification:**

- 1 ms sampling rate
- 0.03% full scale resolution
- 0.06% full scale repeatability
- 0.3 mm Linearity error

**How it installs:**

The Parker CPS requires the use of a magnetic piston. The product will fit T-slot cylinders without any additional mounting hardware.

1. Pivot the sensor into the slot
2. Teach the CPS unit the desired measuring range
3. Tighten set screws

**Dimensions in mm (inch)**

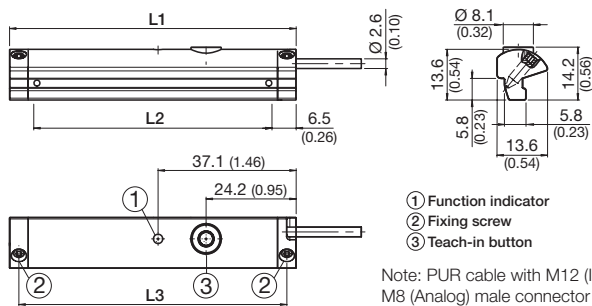

**How it connects:**

Analogue version has a M8 connector and a voltage output of 0-10V as well as a current output of 4-20mA. IO-Link version has a M12 connector and transmits position via 2 bytes of process input data and also allows for parameter control of measuring range and locking of the teach button. It can be controlled by Class A or Class B IO-Link Masters.

**How it works:**

The CPS product detects the position of an actuator via the magnet on the piston. The sensor settings can easily be adjusted during installation using the yellow teach button or during operation over the IO-Link communication. This upgrades the functionality of the pneumatic actuator by making it more intelligent and versatile in support of the Industry 4.0 initiative.

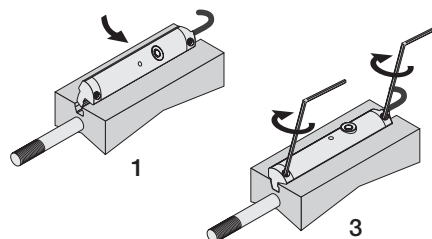

L1	L2 *	L3	Part Number	
			Analog	IO-Link
45	32	40	<b>P8SAGACHA</b>	<b>P8SAGHMHA</b>
77	64	72	<b>P8SAGACHB</b>	<b>P8SAGHMHB</b>
141	128	136	<b>P8SAGACHD</b>	<b>P8SAGHMHD</b>
205	192	200	<b>P8SAGACHF</b>	<b>P8SAGMHF</b>
269	256	264	<b>P8SAGACHH</b>	<b>P8SAGMHMH</b>

\*L2 equal to the measuring range

**Ordering Data - Drop in T-slot, Turn, Screw, it's done**

Output	Measuring length	Configuration Option	Order Code	Weight g	For product series
Analog	32 mm	Teach Button	<b>P8SAGACHA</b>	16	With T-slot groove *
	64 mm		<b>P8SAGACHB</b>	26	
	128 mm		<b>P8SAGACHD</b>	46	
	192 mm		<b>P8SAGACHF</b>	66	
	256 mm		<b>P8SAGACHH</b>	86	
IO-Link	32 mm	Teach Button or IO-Link parameter	<b>P8SAGHMHA</b>	20	With T-slot groove *
	64 mm		<b>P8SAGHMHB</b>	30	
	128 mm		<b>P8SAGHMHD</b>	50	
	192 mm		<b>P8SAGMHF</b>	70	
	256 mm		<b>P8SAGMHMH</b>	90	

\* Required magnetic field sensitivity: 3mT / -2 mT (Analogue) / 3mT (IO-Link)

**Note:** PUR cable with M12 (IO-Link) or M8 (Analogue) male connector knurled nut, 4-pin, 0,3 meter length. Please consult for measuring range 96, 160 & 224 mm.



For inventory, lead times, and kit lookup, visit [www.pdnplu.com](http://www.pdnplu.com)

**B**

Tie Rod Pneumatic Cylinders

4MA Series

4MAJ Series

ACVB Option

LPSO Option

P1D Series

P1F Series

2MNR Series

# Seal Kits

# Tie Rod Pneumatic Cylinders P1F Series

### Complete seal kits consisting of:

- 2 piston seals
- 2 cushioning seals
- 1 wiper / piston rod seal
- 2 o-rings

### Grease Type

Type	Part number
Standard	30 g <b>9127394541</b>
High temperature	30 g <b>9127394521</b>
Low temperature	30 g <b>9127394541</b>



Bore Size mm	Standard Temperature <sup>1)</sup>	High Temperature <sup>1)</sup>	Low Temperature <sup>1)</sup>	Metallic Scraper <sup>1) 2)</sup>	FKM Wiper Seal <sup>1)</sup>	With Dyn. Rod Lock <sup>1)</sup>
32	<b>P1F-6032RN</b>	<b>P1F-6032RF</b>	<b>P1F-6032RL</b>	<b>P1F-6032RQ</b>	<b>P1F-6032RV</b>	<b>P1F-6032RNL</b>
40	<b>P1F-6040RN</b>	<b>P1F-6040RF</b>	<b>P1F-6040RL</b>	<b>P1F-6040RQ</b>	<b>P1F-6040RV</b>	<b>P1F-6040RNL</b>
50	<b>P1F-6050RN</b>	<b>P1F-6050RF</b>	<b>P1F-6050RL</b>	<b>P1F-6050RQ</b>	<b>P1F-6050RV</b>	<b>P1F-6050RNL</b>
63	<b>P1F-6063RN</b>	<b>P1F-6063RF</b>	<b>P1F-6063RL</b>	<b>P1F-6063RQ</b>	<b>P1F-6063RV</b>	<b>P1F-6063RNL</b>
80	<b>P1F-6080RN</b>	<b>P1F-6080RF</b>	<b>P1F-6080RL</b>	<b>P1F-6080RQ</b>	<b>P1F-6080RV</b>	<b>P1F-6080RNL</b>
100	<b>P1F-6100RN</b>	<b>P1F-6100RF</b>	<b>P1F-6100RL</b>	<b>P1F-6100RQ</b>	<b>P1F-6100RV</b>	<b>P1F-6100RNL</b>
125	<b>P1F-6125RN</b>	<b>P1F-6125RF</b>	<b>P1F-6125RL</b>	<b>P1F-6125RQ</b>	<b>P1F-6125RV</b>	<b>P1F-6125RNL</b>

<sup>1)</sup> for through piston rod, add K at the end, ie P1F-6032RNK  
<sup>2)</sup> -30 to +80°C

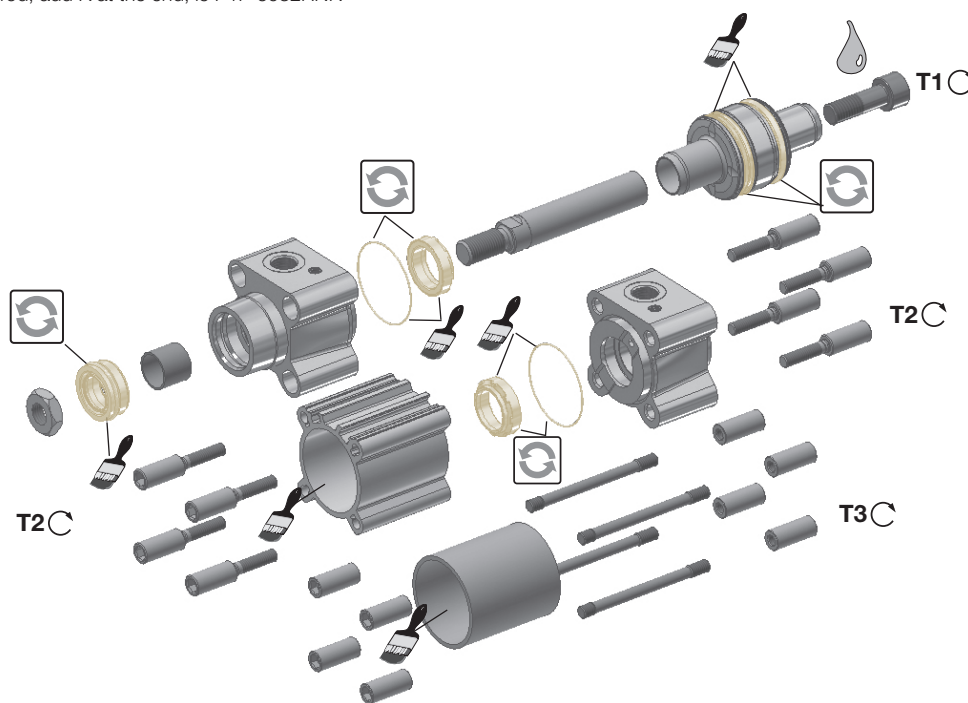

Bore Size mm	Plastic Piston T1 Nm	Al Piston T1 Nm	AF mm	T2 Nm	AF mm	T3 Nm
32	4.5	15	6	11	6	4.5
40	11	30	8	11	6	4.5
50	20	40	10	18	8	9.5
63	20	40	10	18	8	9.5
80	40	120	14	29	6	19
100	120	120	14	29	6	19
125	120	120	14	70	8	40



= Included in seal kit



= Socket head across flats



= Tightening torque



Lubricated with grease



Locking fluid  
 Loctite 270 or Loctite 2701 locking fluid must be used

**B**

Tie Rod Pneumatic Cylinders

4MA Series

4MAJ Series

ACVB Option

LPSO Option

P1D Series

P1F Series

2MNR Series



For inventory, lead times, and kit lookup, visit [www.pdnplu.com](http://www.pdnplu.com)

B140

Parker Hannifin Corporation  
 Pneumatic Division  
 Wadsworth, Ohio  
[www.parker.com/pneumatics](http://www.parker.com/pneumatics)



**Specifying air quality (purity) in accordance with ISO8573-1:2010, the international standard for compressed air quality**

ISO8573-1 is the primary document used from the ISO8573 series as it is this document which specifies the amount of contamination allowed in each cubic metre of compressed air.

ISO8573-1 lists the main contaminants as Solid Particulate, Water and Oil. The purity levels for each contaminant are shown separately in tabular form, however for ease of use, this document combines all three contaminants into one easy to use table.

ISO8573-1:2010 CLASS	Solid Particulate			Mass Concentration mg/m <sup>3</sup>	Water		Oil
	Maximum number of particles per m <sup>3</sup>				Vapor Pressure Dewpoint	Liquid g/m <sup>3</sup>	Total Oil (aerosol liquid and vapor) mg/m <sup>3</sup>
	0,1 - 0,5 micron	0,5 - 1 micron	1 - 5 micron				
0	As specified by the equipment user or supplier and more stringent than Class 1						
1	≤ 20 000	≤ 400	≤ 10	-	≤ -70 °C	-	0,01
2	≤ 400 000	≤ 6 000	≤ 100	-	≤ -40 °C	-	0,1
3	-	≤ 90 000	≤ 1 000	-	≤ -20 °C	-	1
4	-	-	≤ 10 000	-	≤ +3 °C	-	5
5	-	-	≤ 100 000	-	≤ +7 °C	-	-
6	-	-	-	≤ 5	≤ +10 °C	-	-
7	-	-	-	5 - 10	-	≤ 0,5	-
8	-	-	-	-	-	0,5 - 5	-
9	-	-	-	-	-	5 - 10	-
X	-	-	-	> 10	-	> 10	> 10

**Specifying air purity in accordance with ISO8573-1:2010**

When specifying the purity of air required, the standard must always be referenced, followed by the purity class selected for each contaminant (a different purity class can be selected for each contamination if required).

An example of how to write an air quality specification is shown below:

**ISO 8573-1:2010 Class 1.2.1**

ISO 8573-1:2010 refers to the standard document and its revision, the three digits refer to the purity classifications selected for solid particulate, water and total oil. Selecting an air purity class of 1.2.1 would specify the following air quality when operating at the standard's reference conditions:

**Class 1 - Particulate**

In each cubic meter of compressed air, the particulate count should not exceed 20,000 particles in the 0.1 - 0.5 micron size range, 400 particles in the 0.5 - 1 micron size range and 10 particles in the 1 - 5 micron size range.

**Class 2 - Water**

A pressure dewpoint (PDP) of -40°C or better is required and no liquid water is allowed.

**Class 1 - Oil**

In each cubic meter of compressed air, not more than 0.01mg of oil is allowed. This is a total level for liquid oil, oil aerosol and oil vapor.

**ISO8573-1:2010 Class zero**

- Class 0 does not mean zero contamination.
- Class 0 requires the user and the equipment manufacturer to agree contamination levels as part of a written specification.
- The agreed contamination levels for a Class 0 specification should be within the measurement capabilities of the test equipment and test methods shown in ISO8573 Pt 2 to Pt 9.
- The agreed Class 0 specification must be written on all documentation to be in accordance with the standard.
- Stating Class 0 without the agreed specification is meaningless and not in accordance with the standard.
- A number of compressor manufacturers claim that the delivered air from their oil-free compressors is in compliance with Class 0.
- If the compressor was tested in clean room conditions, the contamination detected at the outlet will be minimal. Should the same compressor now be installed in typical urban environment, the level of contamination will be dependent upon what is drawn into the compressor intake, rendering the Class 0 claim invalid.
- A compressor delivering air to Class 0 will still require purification equipment in both the compressor room and at the point of use for the Class 0 purity to be maintained at the application.
- Air for critical applications such as breathing, medical, food, etc typically only requires air quality to Class 2.2.1 or Class 2.1.1.
- Purification of air to meet a Class 0 specification is only cost effective if carried out at the point of use.

<b>B</b>	Tie Rod Pneumatic Cylinders
	4MA Series
	4MAJ Series
	ACVB Option
	LPSO Option
	P1D Series
	P1F Series
	2MNR Series



For inventory, lead times, and kit lookup, visit [www.pdnplu.com](http://www.pdnplu.com)



2MNR Series – 1-1/2" to 4" Bore Size

<b>B</b>	Tie Rod Pneumatic Cylinders
	4MA Series
	4MAJ Series
	ACVB Option
	LP50 Option
	P1D Series
	P1F Series
	2MNR Series

**MULTIPLE PISTON RODS**

Three hard-chrome plated and polished piston rods provide stability and strength for higher bearing support. Precision machining provides precise fit for antirotation.

**RETAINER**

Retainer is easily removed for access to rod gland assemblies.

**CHECK SEAL CUSHION**

Molded urethane cushion combines the sealing capabilities of a lipseal for effective cushioning with check valve action for quick stroke reversal. "Floating" cushions assure cushion repeatability and long life.

**ROUNDED LIP PISTON SEALS**

Carboxylated nitrile w/PTFE seals glide over lubricant film instead of scraping it off.

**TOOLING PLATE**

Cold rolled carbon steel tooling plate with corrosionresistant finish is easily removable for maintenance.

**CUSHION NEEDLE VALVES**

Adjustable captive design makes precise adjustment quick and easy. Can be adjusted while cylinder is under pressure.

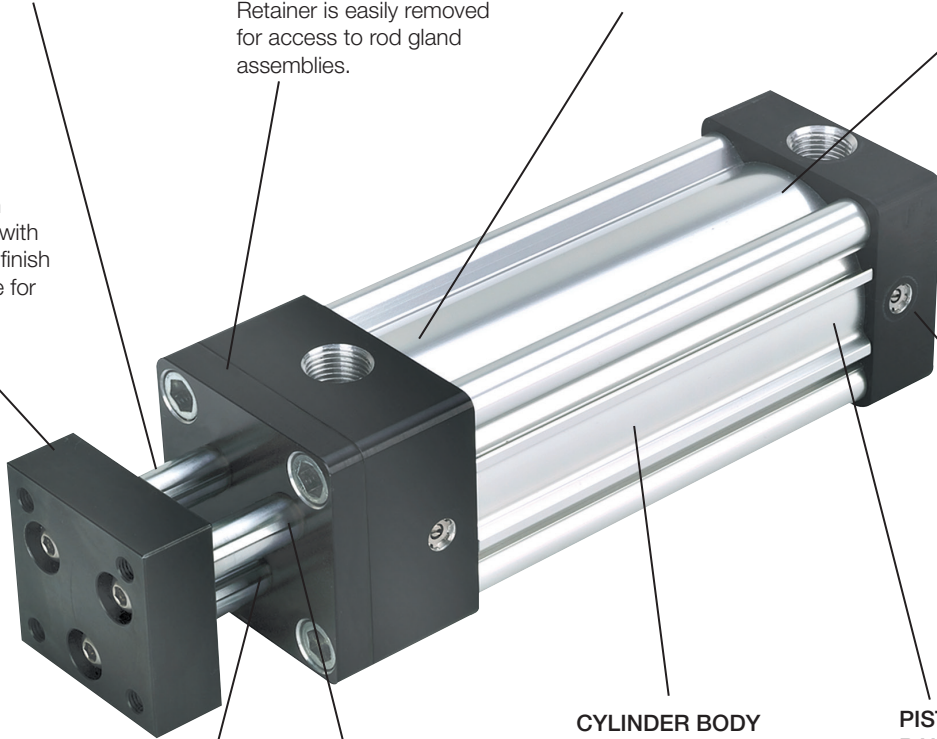

**CYLINDER BODY**

Lightweight anodized aluminum body is wear resistant. The smooth extruded design eliminates areas for contamination.

**PISTON AND WEAR BAND**

Aluminum lightweight piston with nylon wear band (not shown) eliminates metal-to-metal contact to extend cylinder life. Formed, shaped wear band makes installation and repair easier than regular wear strip.

**ROD SEAL/WIPER**

Combination rod seal and rod wiper, available in either nitrile or fluorocarbon, is inserted into the bearing, creating a rod gland. Completely self-compensating for zero leakage at all pressures.

**ROD BEARING**

Permanently lubricated sintered bronze bearing provides excellent performance in nonlube applications. Bearings are easily removed for service.

## Features

- NFPA Interchangeable
- Bore sizes: 1-1/2 to 4 inches
- Single end or double end designs
- Mounting styles: 9 NFPA standard
- Mounts plus 1 base bar style
- Non-rotating, multi-rod design
- Strokes: available in any practical stroke length
- Cushions: optional at either end or both ends of stroke

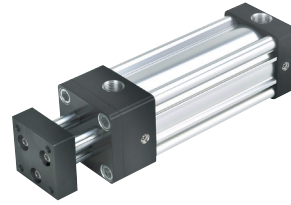

### Operating information

Operating pressure: maximum air service	250 PSIG (17 bar)
Temperature range – Standard seals	-10°F to 165°F (-23°C to 73°C)
Fluorocarbon seals	-20°F to 250°F (-29°C to 121°C)
Filtration requirements:	40 micron, dry filtered air

### Ordering information

**2.00** **J** **2MNR** **U** **T** **9** **A** **6.000**

<b>Bore Size *</b> 1.50 2.00 2.50 3.25 4.00 <small>* Required for basic cylinder model number. For bumpers, please consult factory.</small>	<b>Mounting Style</b> Specify mounting style code (see table on following chart below)	<b>Series</b> 2MNR	<b>Ports</b> U NPTF R BSPP	<b>Seals</b> Blank Standard (nitrile seals) V Fluorocarbon Seals <small>Magnetic piston option is available with standard seals only.</small>	<b>Tooling Plate</b> T Standard Plate	<b>Stroke Length</b> Specify stroke length required in inches.	<b>Cushion Cap End</b> Use "C" only if cap end cushion is required.	<b>Piston Rod Thread Type</b> A Standard (UNF unified thread)	<b>Piston Rod Thread Style</b> 9 Standard 3 Special (and specify all dimensions required)	<b>Cushion Head End</b> Use "C" only if head end cushion is required.
---	---	-----------------------	----------------------------------	--	--	---	--	--	---	--

**Single End Cylinder**

**Piston Type**  
Blank Standard  
3 Piston Magnet

**Special Modification**  
Specify "S" only for special modification only.

**Sensors**  
See section L for sensors.

**NOTE:** Always specify thread KK, thread depth A and W when special tooling plate requires

### Cylinder mounting styles

Mounting style code	NFPA style	Mounting description
T	MX0	No mount (basic)
TC	MX2	Tie rods extended cap end
F	MS4	Side tapped
BB †	MP1	Cap Fixed Clevis
BC †	MP2	Cap Detachable Clevis
BE †	MP4	Detachable Pivot Eye
H †	MF2	Cap Rectangular Flange
J †	MF1	Head Rectangular Flange
TE	MX5	Sleeve Nut (Cap End Only)
NB	Non NFPA Style	Base Bar

† Mounting styles with asterisks can be ordered assembled to the cylinder or as a basic (T) no-mount cylinder.

### How to Order Parker 2MNR Series Cylinders with Sensors:

Sensors are not mounted to the cylinder prior to shipment.

When ordering a cylinder to accommodate a sensor:

1. Derive a proper model number as shown in the table above.
2. Place a "3" in the piston column of the model number.
3. Order appropriate brackets and sensor as separate line items. See Section L for specifications and part numbers.

**Example:** For cylinder prepared for sensor  
2.00CJ2MNR3UT9AC 6.000

**For ordering purposes, when special options or common modifications are requested, the factory will assign a sequential part number in place of the model number.**



For inventory, lead times, and kit lookup, visit [www.pdnplu.com](http://www.pdnplu.com)

**2MNR Mounting Styles**

Mounting Style	NFPA Mounting	Description	Bore Size
T	MX0	Basic Mount	1-1/2 - 4
TC	MX2	Tie Rod Extended Cap End	1-1/2 - 4
TE	MX5	Sleeve Nut (Cap end only)	1-1/2 - 4
F	MS4	Side Tap )	1-1/2 - 4
J	MF1	Head Rectangular Flange	1-1/2 - 4
H	MF2	Cap Rectangular Flange	1-1/2 - 4

Mounting Style	NFPA Mounting	Description	Bore Size
BC	MP2	Cap Detachable Clevis	1-1/2 - 4
BB	MP1	Cap Fixed Clevis	1-1/2 - 4
BE	MP4	Detachable Pivot Eye	1-1/2 - 4
NB		Base Bar	1-1/2 - 4

<b>B</b>	<b>Tie Rod Pneumatic Cylinders</b>	<b>Series</b>	4MA
			4MAJ
			ACVB
			Option
			LP50
			Option
			P1D
			Series
			P1F
			Series
2MNR			
Series			



For inventory, lead times, and kit lookup, visit [www.pdnplu.com](http://www.pdnplu.com)

**Air Cylinder Cushion Ratings**

Single Ended Cylinders

Bore Size	Cylinder End	Rating With No Back Pressure	Rating With Back Pressure
1-1/2"	Cap	12	17
	Rod	6	11
2"	Cap	14	20
	Rod	10	14
2-1/2"	Cap	17	23
	Rod	11	15
3-1/4"	Cap	21	26
	Rod	15	20
4"	Cap	23	28
	Rod	17	23

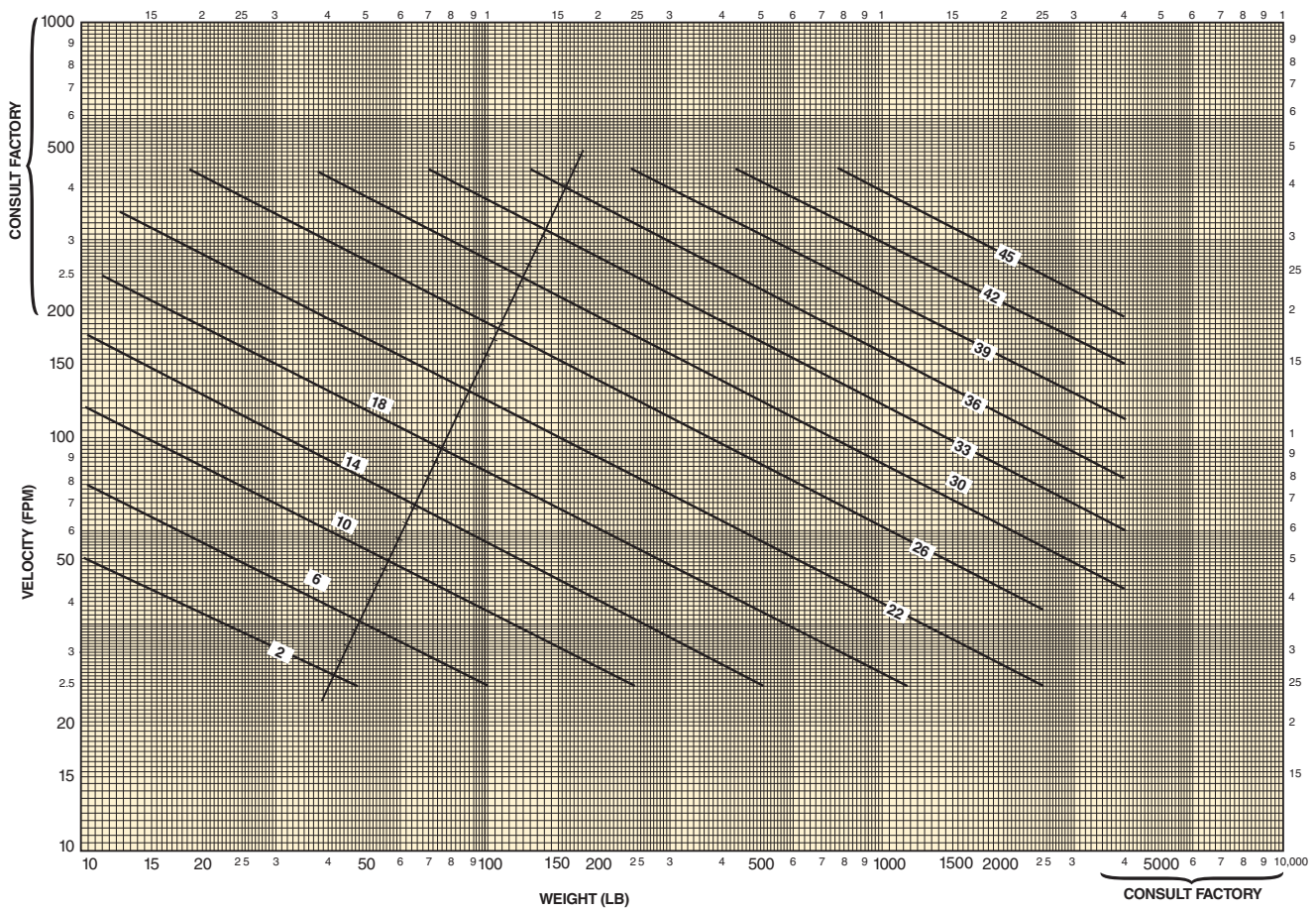

**B**

Tie Rod Pneumatic Cylinders

4MA Series

4MAJ Series

ACVB Option

LPSO Option

P1D Series

P1F Series

**2MNR Series**



For inventory, lead times, and kit lookup, visit [www.pdnplu.com](http://www.pdnplu.com)

B145

Parker Hannifin Corporation  
 Pneumatic Division  
 Wadsworth, Ohio  
[www.parker.com/pneumatics](http://www.parker.com/pneumatics)

**Loading Information**

**Side Load Versus Stroke**

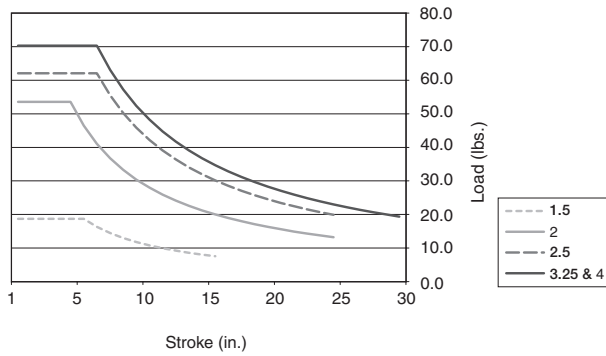

**Side Load**

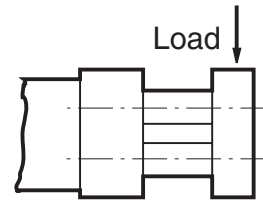

**Torsional Load**

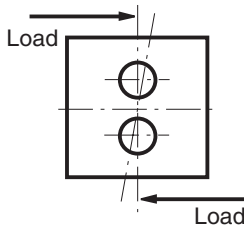

**Torsional Load Versus Stroke**

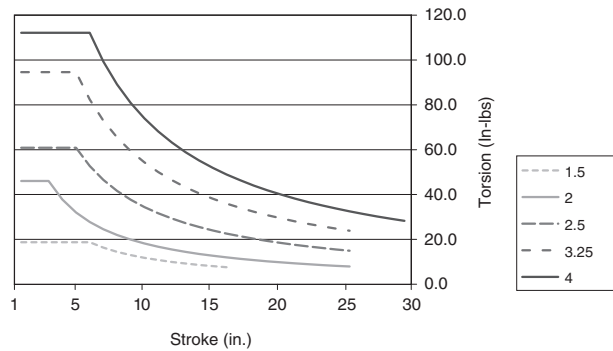

**Theoretical Extend and Retract Forces in Pounds**

Bore Size	Movement	Effective Area (in <sup>2</sup> )	Pressure (PSI)								Cu. ft. of Displacement Per Inch of Stroke
			20	40	60	80	100	150	200	250	
1-1/2"	Extend	1.767	35	71	106	141	177	265	353	442	0.00102
	Retract	1.537	31	61	92	123	154	231	307	384	0.00089
2"	Extend	3.142	63	126	188	251	314	471	628	785	0.00182
	Retract	2.553	51	102	153	204	255	383	511	638	0.00148
2-1/2"	Extend	4.909	98	196	295	393	491	736	982	1227	0.00284
	Retract	3.988	80	160	239	319	399	598	798	997	0.00231
3-1/4"	Extend	8.296	166	332	498	664	830	1244	1659	2074	0.00480
	Retract	7.375	148	295	443	590	738	1106	1475	1844	0.00427
4"	Extend	12.566	251	503	754	1005	1257	1885	2513	3142	0.00727
	Retract	11.646	233	466	699	932	1165	1747	2329	2911	0.00674

**B**  
 Tie Rod Pneumatic Cylinders  
 4MA Series  
 4MAJ Series  
 ACV/B Option  
 LPSO Option  
 P1D Series  
 P1F Series  
 2MNR Series



For inventory, lead times, and kit lookup, visit [www.pdnplu.com](http://www.pdnplu.com)

**Basic Single End – Style T (NFPA MX0)**

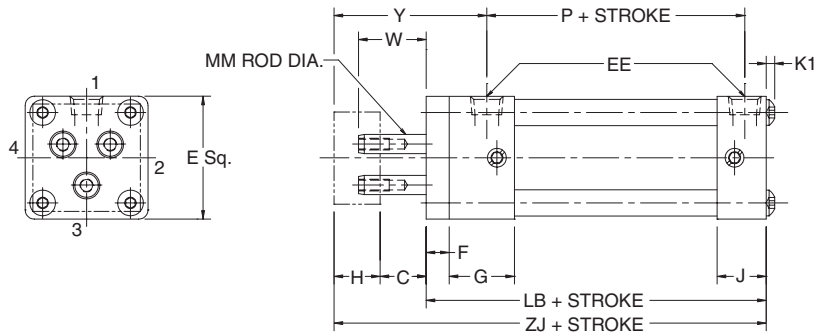
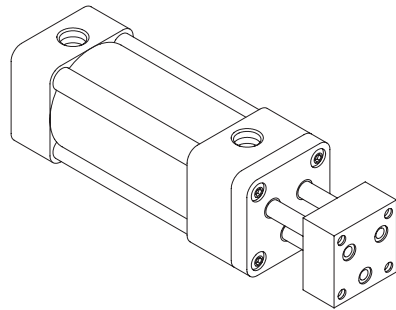

**Style T and Dimensions**

Bore	Rod Dia. mm	C	E	EE (NPTF)	F	G	H	J	K1	W	Y	Add Stroke		
												LB	P	ZJ
1-1/2	8mm	3/4	2	1/4	3/8	1-7/16	3/4	15/16	1/8	1.10	2-3/4	4	2-5/16	5-1/2
2	12mm	3/4	2-1/2	1/4	3/8	1-7/16	3/4	15/16	5/32	1.10	2-3/4	4	2-5/16	5-1/2
2-1/2	16mm	3/4	3	3/8	3/8	1-7/16	1	15/16	5/32	1.35	3-1/16	4-1/8	2-3/8	5-7/8
3-1/4	16mm	3/4	3-3/4	1/2	5/8	1-11/16	1	1-3/16	3/16	1.10	3-7/16	4-7/8	2-5/8	6-5/8
4	16mm	3/4	4-1/2	1/2	5/8	1-11/16	1	1-3/16	3/16	1.10	3-7/16	4-7/8	2-5/8	6-5/8

**Tie Rods Extend Cap End – Style TC**

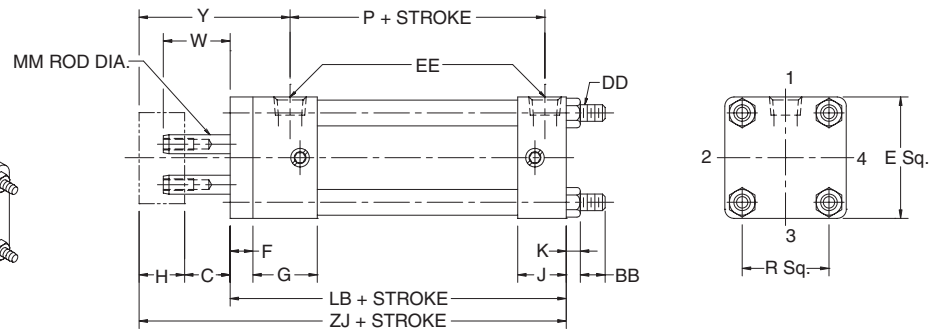
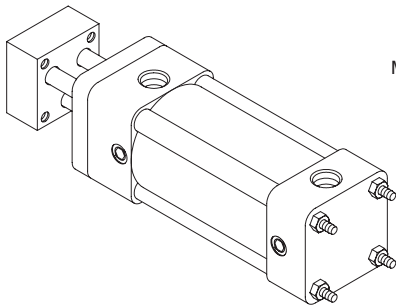

**Style TC and Dimensions**

Bore	Rod Dia. mm	BB	C	DD	E	EE (NPTF)	F	G	H	J	K	R	W	Y	Add Stroke		
															LB	P	ZJ
1-1/2	8mm	1	3/4	1/4-28	2	1/4	3/8	1-7/16	3/4	15-16	1/4	1.43	1.10	2-3/4	4	2-5/16	5-1/2
2	12mm	1-1/8	3/4	5/16-24	2-1/2	1/4	3/8	1-7/16	3/4	15-16	5/16	1.84	1.10	2-3/4	4	2-5/16	5-1/2
2-1/2	16mm	1-1/8	3/4	5/16-24	3	3/8	3/8	1-7/16	1	15-16	5/16	2.19	1.35	3-1/16	4-1/8	2-3/8	5-7/8
3-1/4	16mm	1-3/8	3/4	3/8-24	3-3/4	1/2	5/8	1-11/16	1	1-3/16	3/8	2.76	1.10	3-7/16	4-7/8	2-5/8	6-5/8
4	16mm	1-3/8	3/4	3/8-24	4-1/2	1/2	5/8	1-11/16	1	1-3/16	3/8	3.32	1.10	3-7/16	4-7/8	2-5/8	6-5/8

**B**

Tie Rod Pneumatic  
Cylinders

4MA  
Series

4MAJ  
Series

ACVB  
Option

LPSO  
Option

P1D  
Series

P1F  
Series

2MNR  
Series



**Head Rectangular Flange – Style J (NFPA MF1)**

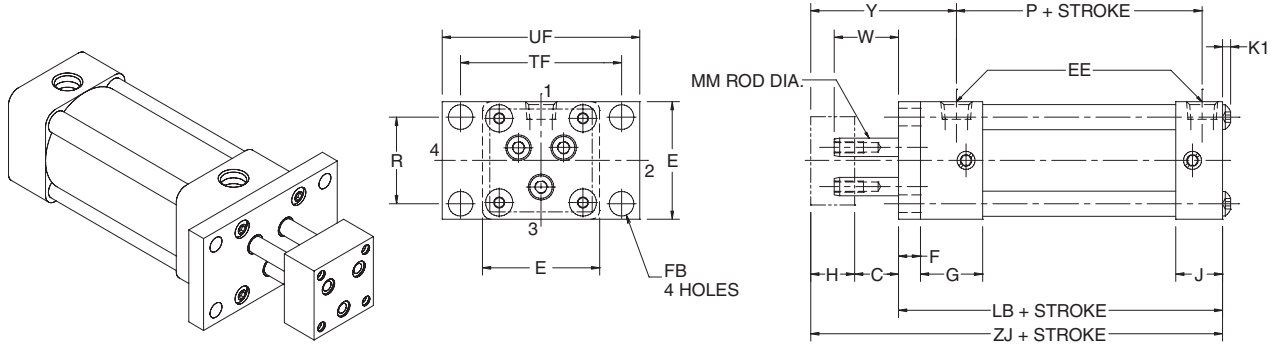

**Style J and Dimensions**

Bore	Rod Dia. mm	C	E	EE (NPTF)	F	FB	G	H	J	K1	R	TF	UF	W	Y	Add Stroke		
																LB	P	ZJ
1-1/2	8mm	3/4	2	1/4	3/8	5/16	1-7/16	3/4	15/16	1/8	1.43	2-3/4	3-3/8	1.10	2-3/4	4	2-5/16	5-1/2
2	12mm	3/4	2-1/2	1/4	3/8	3/8	1-7/16	3/4	15/16	5/32	1.84	3-3/8	4-1/8	1.10	2-3/4	4	2-5/16	5-1/2
2-1/2	16mm	3/4	3	3/8	3/8	3/8	1-7/16	1	15/16	5/32	2.19	3-7/8	4-5/8	1.35	3-1/16	4-1/8	2-3/8	5-7/8
3-1/4	16mm	3/4	3-3/4	1/2	5/8	7/16	1-11/16	1	1-3/16	3/16	2.76	4-11/16	5-1/2	1.10	3-7/16	4-7/8	2-5/8	6-5/8
4	16mm	3/4	4-1/2	1/2	5/8	7/16	1-11/16	1	1-3/16	3/16	3.32	5-7/16	6-1/4	1.10	3-7/16	4-7/8	2-5/8	6-5/8

**Cap Rectangular Flange – Style H (NFPA MF2)**

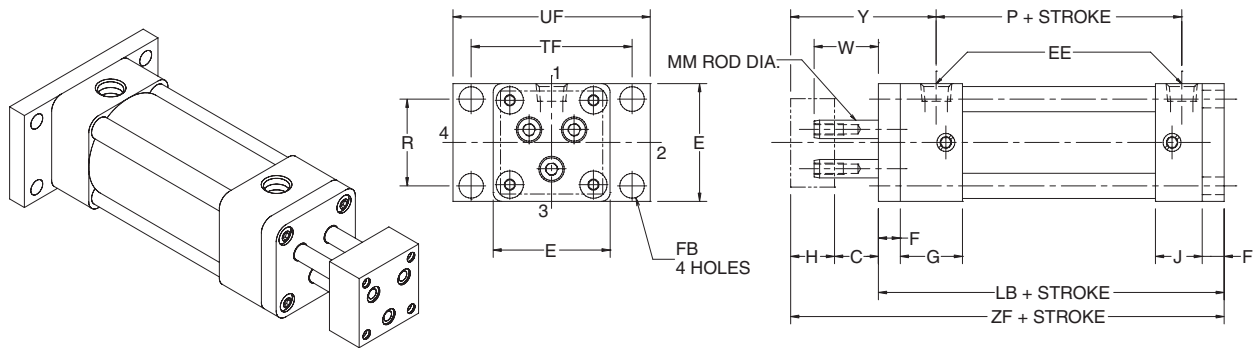

**Style H and Dimensions**

Bore	Rod Dia. mm	C	E	EE (NPTF)	F	FB	G	H	J	R	TF	UF	W	Y	Add Stroke		
															LB	P	ZJ
1-1/2	8mm	3/4	2	1/4	3/8	5/16	1-7/16	3/4	15-16	1.43	2-3/4	3-3/8	1.10	2-3/4	4-3/8	2-5/16	5-7/8
2	12mm	3/4	2-1/2	1/4	3/8	3/8	1-7/16	3/4	15-16	1.84	3-3/8	4-1/8	1.10	2-3/4	4-3/8	2-5/16	5-7/8
2-1/2	16mm	3/4	3	3/8	3/8	3/8	1-7/16	1	15-16	2.19	3-7/8	4-5/8	1.35	3-1/16	4-1/2	2-3/8	6-1-4
3-1/4	16mm	3/4	3-3/4	1/2	5/8	7/16	1-11/16	1	1-3/16	2.76	4-11/16	5-1/2	1.10	3-7/16	5-1/2	2-5/8	7-1/4
4	16mm	3/4	4-1/2	1/2	5/8	7/16	1-11/16	1	1-3/16	3.32	5-7/16	6-1/4	1.10	3-7/16	5-1/2	2-5/8	7-1/4



**Sleeve Nut (Cap End Only) – Style TE (NFPA MX5)**

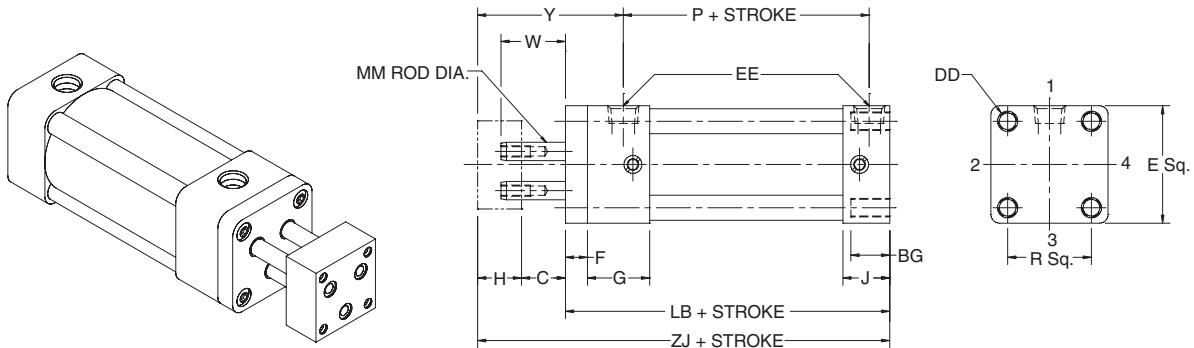

**Style TE and Dimensions**

Bore	Rod Dia. mm	BG	C	DD	E	EE (NPTF)	F	G	H	J	R	W	Y	Add Stroke			
														LB	P	ZF	ZJ
1-1/2	8mm	0.45	3/4	1/4-28	2	1/4	3/8	1-7/16	3/4	15/16	1.43	1.10	2-3/4	4	2-5/16	5.10	5-1/2
2	12mm	0.48	3/4	5/16-24	2-1/2	1/4	3/8	1-7/16	3/4	15/16	1.84	1.10	2-3/4	4	2-5/16	5.10	5-1/2
2-1/2	16mm	0.48	3/4	5/16-24	3	3/8	3/8	1-7/16	1	15/16	2.19	1.35	3-1/16	4-1/8	2-3/8	5.35	5-7/8
3-1/4	16mm	0.50	3/4	3/8-24	3-3/4	1/2	5/8	1-11/16	1	1-3/16	2.76	1.10	3-7/16	4-7/8	2-5/8	5.23	6-5/8
4	16mm	0.50	3/4	3/8-24	4-1/2	1/2	5/8	1-11/16	1	1-3/16	3.32	1.10	3-7/16	4-7/8	2-5/8	5.98	6-5/8

**Side Tapped Mount – Style F (NFPA MS4)**

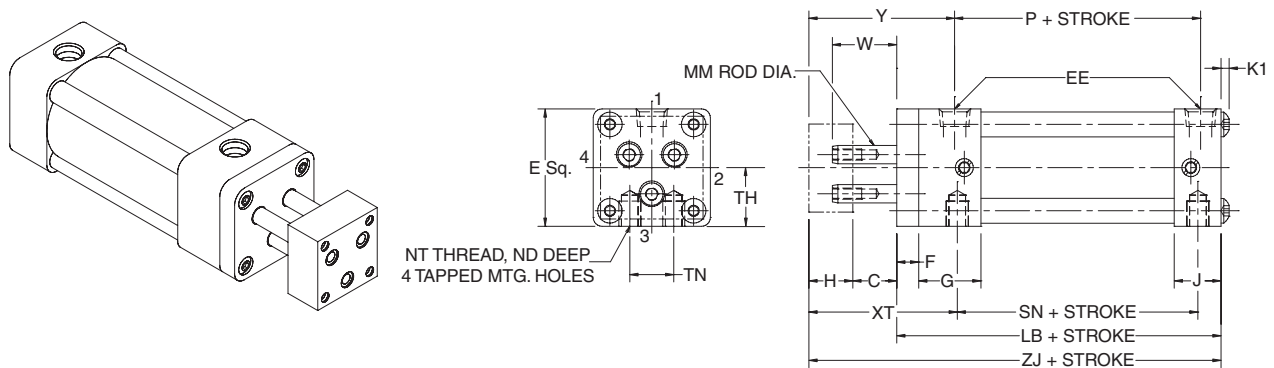

**Style TC and Dimensions**

Bore	Rod Dia. mm	C	E	EE (NPTF)	F	G	H	J	K1	ND	NT	TH ±0.003	TN	W	XT	Y	Add Stroke			
																	LB	P	SN	ZJ
1-1/2	8mm	3/4	2	1/4	3/8	1-7/16	3/4	15-16	1/8	3/8	1/4-20	0.993	5/8	1.10	2-13/16	2-3/4	4	2-5/16	2-1/4	5-1/2
2	12mm	3/4	2-1/2	1/4	3/8	1-7/16	3/4	15-16	5/32	7/16	5/16-18	1.243	7/8	1.10	2-13/16	2-3/4	4	2-5/16	2-1/4	5-1/2
2-1/2	16mm	3/4	3	3/8	3/8	1-7/16	1	15-16	5/32	5/8	3/8-16	1.493	1-1/4	1.35	3-1/16	3-1/16	4-1/8	2-3/8	2-3/8	5-7/8
3-1/4	16mm	3/4	3-3/4	1/2	5/8	1-11/16	1	1-3/16	3/16	3/4	1/2-13	1.868	1-1/2	1.10	3-7/16	3-7/16	4-7/8	2-5/8	2-3/8	6-5/8
4	16mm	3/4	4-1/2	1/2	5/8	1-11/16	1	1-3/16	3/16	3/4	1/2-13	2.243	2-1/16	1.10	3-7/16	3-7/16	4-7/8	2-5/8	2-3/8	6-5/8

**B**

Tie Rod Pneumatic  
Cylinders

4MA  
Series

4MAJ  
Series

ACVB  
Option

LPSO  
Option

P1D  
Series

P1F  
Series

2MNR  
Series

**Cap Detachable Clevis – Style BC (NFPA MP2)**

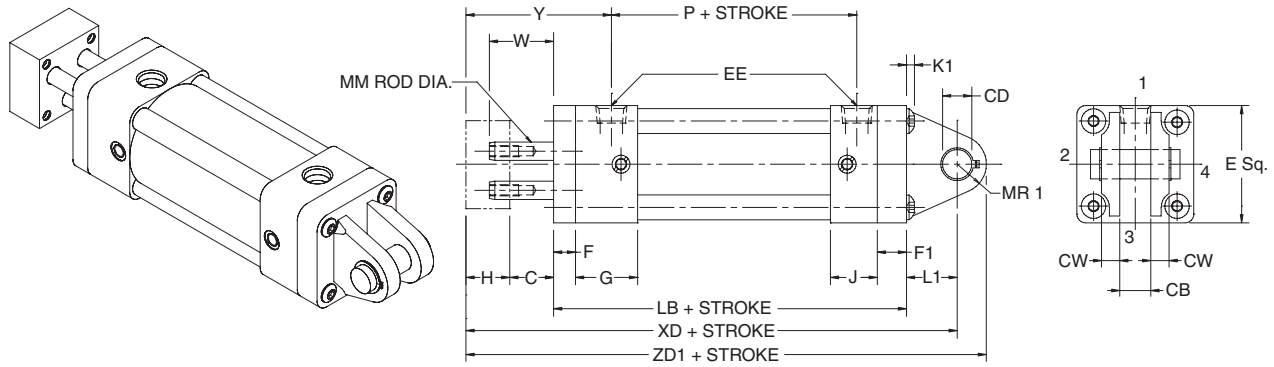

**Style BC and Dimensions**

Series	Bore	Rod Dia. mm	C	CB	CD +.000 -.002	CW	E	EE (NPTF)	F	F1	G	H	J	K1	L1	MR1	W	Y	Add Stroke			
																			LB	P	XD	ZD1
4MA	1-1/2	8mm	3/4	3/4	0.501	1/2	2	1/4	3/8	3/8	1-7/16	3/4	15/16	1/8	3/4	1/2	1.10	2-3/4	4-3/8	2-5/16	6-5/8	7-1/8
	2	12mm	3/4	3/4	0.501	1/2	2-1/2	1/4	3/8	3/8	1-7/16	3/4	15/16	5/32	3/4	1/2	1.10	2-3/4	4-3/8	2-5/16	6-5/8	7-1/8
	2-1/2	16mm	3/4	3/4	0.501	1/2	3	3/8	3/8	3/8	1-7/16	1	15/16	5/32	3/4	1/2	1.35	3-1/16	4-1/2	2-3/8	7	7-1/2
4MAJ	3-1/4	16mm	3/4	1-1/4	0.751	5/8	3-3/4	1/2	5/8	5/8	1-11/16	1	1-3/16	3/16	1-1/4	3/4	1.10	3-7/16	5-1/2	2-5/8	8-1/2	9-1/4
	4	16mm	3/4	1-1/4	0.751	5/8	4-1/2	1/2	5/8	5/8	1-11/16	1	1-3/16	3/16	1-1/4	3/4	1.10	3-7/16	5-1/2	2-5/8	8-1/2	9-1/4

**Cap Fixed Clevis – Style BB (NFPA MP1)**

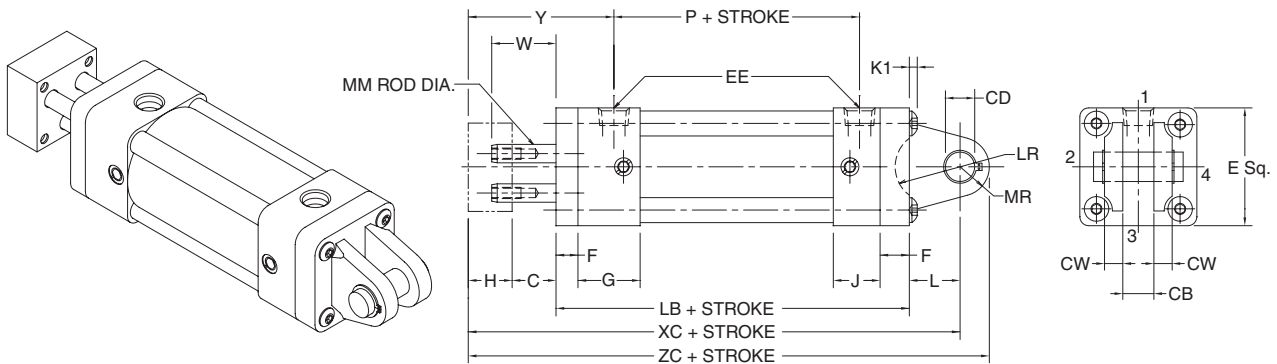

**Style BB and Dimensions**

Series	Bore	Rod Dia. mm	C	CB	CD +.000 -.002	CW	E	EE (NPTF)	F	G	H	J	L	LR	MR	W	Y	Add Stroke			
																		LB	P	XC	ZC
2MNR	1-1/2	8mm	3/4	3/4	0.501	1/2	2	1/4	3/8	1-7/16	3/4	15-16	15/16	3/4	5/8	1.10	2-3/4	4-3/8	2-5/16	6-1/4	6-7/8
	2	12mm	3/4	3/4	0.501	1/2	2-1/2	1/4	3/8	1-7/16	3/4	15-16	15/16	3/4	5/8	1.10	2-3/4	4-3/8	2-5/16	6-1/4	6-7/8
	2-1/2	16mm	3/4	3/4	0.501	1/2	3	3/8	3/8	1-7/16	1	15-16	15/16	3/4	5/8	1.35	3-1/16	4-1/2	2-3/8	6-5/8	7-1/4
2MNR	3-1/4	16mm	3/4	1-1/4	0.751	5/8	3-3/4	1/2	5/8	1-11/16	1	1-3/16	1-3/16	1	15/16	1.10	3-7/16	5-1/2	2-5/8	7-7/8	8-13/16
	4	16mm	3/4	1-1/4	0.751	5/8	4-1/2	1/2	5/8	1-11/16	1	1-3/16	1-3/16	1	15/16	1.10	3-7/16	5-1/2	2-5/8	7-7/8	8-13/16

**Detachable Pivot Eye – Style BE (NFPA MP4)**

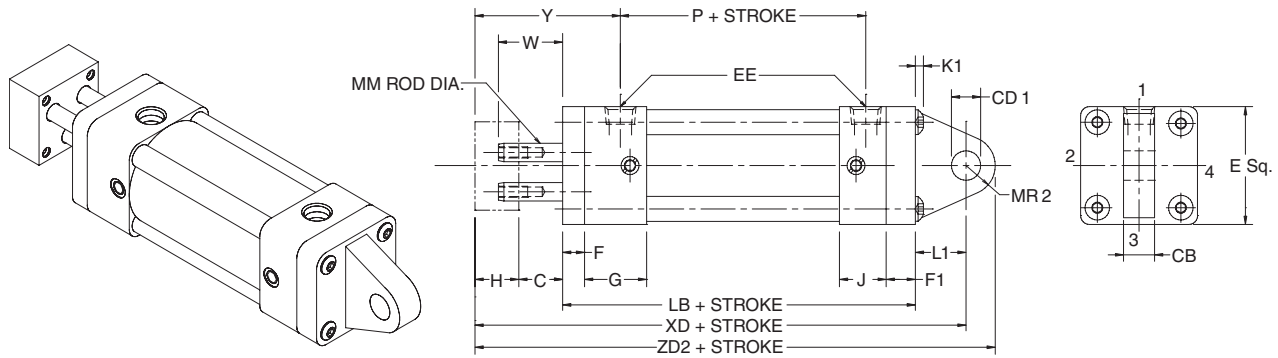

**Style BE and Dimensions**

Bore	Rod Dia. mm	C	CB	CD +.000 -.002	E	EE (NPTF)	F	F1	G	H	J	K1	L1	MR2	W	Y	Add Stroke			
																	LB	P	XD	ZD2
1-1/2	8mm	3/4	3/4	0.500	2	1/4	3/8	3/8	1-7/16	3/4	15/16	1/8	3/4	5/8	1.10	2-3/4	4-3/8	2-5/16	6-5/8	7-1/4
2	12mm	3/4	3/4	0.500	2-1/2	1/4	3/8	3/8	1-7/16	3/4	15/16	5/32	3/4	5/8	1.10	2-3/4	4-3/8	2-5/16	6-5/8	7-1/4
2-1/2	16mm	3/4	3/4	0.500	3	3/8	3/8	3/8	1-7/16	1	15/16	5/32	3/4	11/16	1.35	3-1/16	4-1/2	2-3/8	7	7-11/16
3-1/4	16mm	3/4	1-1/4	0.750	3-3/4	1/2	5/8	5/8	1-11/16	1	1-3/16	3/16	1-1/4	7/8	1.10	3-7/16	5-1/2	2-5/8	8-1/2	9-3/8
4	16mm	3/4	1-1/4	0.750	4-1/2	1/2	5/8	5/8	1-11/16	1	1-3/16	3/16	1-1/4	7/8	1.10	3-7/16	5-1/2	2-5/8	8-1/2	9-3/8

**Base Bar – Style NB**

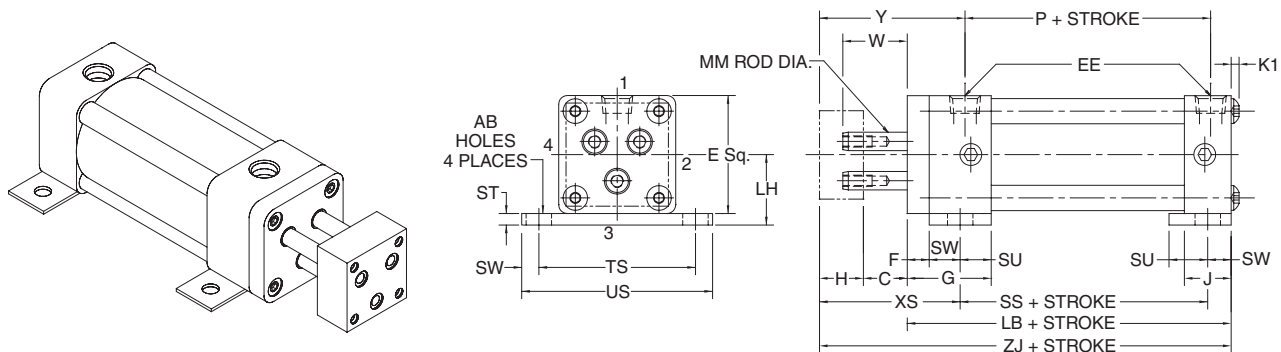

**Style NB and Dimensions**

Bore	Rod Dia. mm	AB	C	E	EE (NPTF)	F	G	H	J	K1	LH ±.000	ST	SU	SW	TS	US	W	XS	Y	Add Stroke			
																				LB	P	SS	ZJ
1-1/2	8mm	7/16	3/4	2	1/4	3/8	1-1/2	3/4	15-16	1/8	15/16	1/4	1-1/8	3/8	2-3/4	3-1/2	1.10	2-1/4	2-3/4	4	2-5/16	2-7/8	5-1/2
2	12mm	7/16	3/4	2-1/2	1/4	3/8	1-1/2	3/4	15-16	5/32	15/16	1/4	1-1/8	3/8	3-1/4	4	1.10	2-1/4	2-3/4	4	2-5/16	2-7/8	5-1/2
2-1/2	16mm	7/16	3/4	3	3/8	3/8	1-1/2	1	15-16	5/32	15/16	3/8	1-1/8	3/8	3-3/4	4-1/2	1.35	2-1/2	3-1/16	4-1/8	2-3/8	3	5-7/8
3-1/4	16mm	9/16	3/4	3-3/4	1/2	5/8	1-3/4	1	1-3/16	3/16	1-3/16	1/2	1-1/4	1/2	4-3/4	5-3/4	1.10	2-7/8	3-7/16	4-7/8	2-5/8	3-1/4	6-5/8
4	16mm	9/16	3/4	4-1/2	1/2	5/8	1-3/4	1	1-3/16	3/16	1-3/16	1/2	1-1/4	1/2	5-1/2	6-1/2	1.10	2-7/8	3-7/16	4-7/8	2-5/8	3-1/4	6-5/8

**B**

Tie Rod Pneumatic  
Cylinders

4MA  
Series

4MAJ  
Series

ACVB  
Option

LPSO  
Option

P1D  
Series

P1F  
Series

2MNR  
Series



**Standard Tooling Plate – Style T**

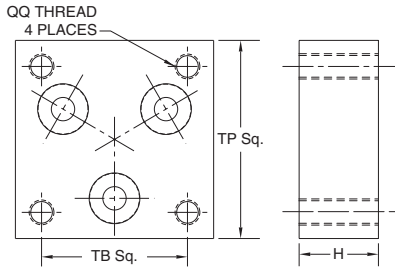

Bore	H	QQ	TB	TP
1-1/2	3/4	10-32	1.12	1-1/2
2	3/4	1/4-28	1.43	2
2-1/2	1	5/16-24	1.84	2-1/2
3-1/4	1	3/8-24	2.19	3-1/4
4	1	3/8-24	2.76	4

**Mounting Plate & Eye Bracket**

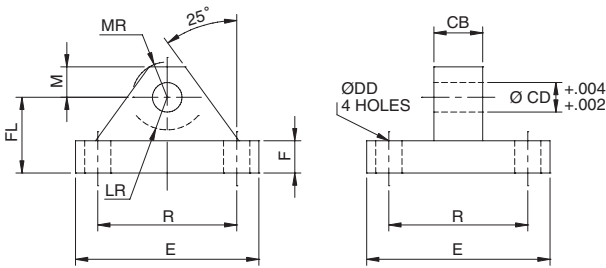

**Clevis Bracket**

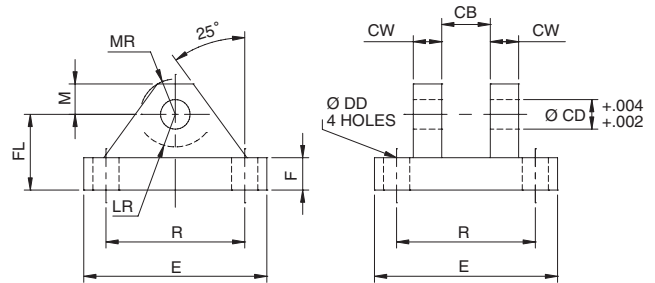

Bore Size	1-1/2, 2, 2-1/2	3-1/4, 4
Part Number	1458060050	1458060075
CB	3/4	1-1/4
CD	1/2	3/4
DD	13/32	17/32
E	2-1/2	3-1/2
F	3/8	5/8
FL	1-1/8	1-7/8
LR	3/4	1-1/4
M	1/2	3/4
MR	9/16	7/8
R	1.63	2.55

Bore Size	1-1/2, 2, 2-1/2	3-1/4, 4
Part Number	1458050050	1458050075
CB	3/4	1-1/4
CD	1/2	3/4
CW	1/2	5/8
DD	13/32	17/32
E	3-1/2	5
F	1/2	5/8
FL	1-1/2	1-7/8
LR	3/4	1-3/16
M	1/2	3/4
MR	5/8	2/32
R	2.55	3.82

**Pivot Pin**

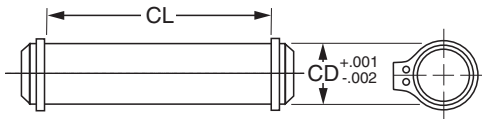

Part Number	0683680000	068369000
CD	1/2	3/4
CL	1-7/8	2-5/8

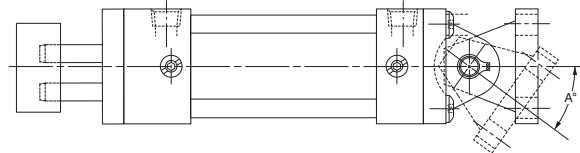

Bore Size	1-1/2	2	2-1/2	3-1/4	4
Angle A *	52	43	29	50	49

\* Angle of rotation specified is for BB style mount only.

**Seal Kits**

Bore Size	Part Number	
	Standard Seal Kit	Fluorocarbon Seal Kit
1-1/2	<b>SG2MNR1501</b>	<b>SG2MNR1505</b>
2	<b>SG2MNR2001</b>	<b>SG2MNR2005</b>
2-1/2	<b>SG2MNR2501</b>	<b>SG2MNR2505</b>
3-1/4	<b>SG2MNR3201</b>	<b>SG2MNR3205</b>
4	<b>SG2MNR4001</b>	<b>SG2MNR4005</b>

**B**

Tie Rod Pneumatic  
Cylinders

4MA  
Series

4MAJ  
Series

ACVB  
Option

LPSO  
Option

P1D  
Series

P1F  
Series

2MNR  
Series



For inventory, lead times, and kit lookup, visit [www.pdnplu.com](http://www.pdnplu.com)

<b>B</b>
Tie Rod Pneumatic Cylinders
4MA Series
4MAJ Series
ACVB Option
LP50 Option
P1D Series
P1F Series
2MNR Series



For inventory, lead times, and kit lookup, visit [www.pdnplu.com](http://www.pdnplu.com)

**Round Body Design  
Pneumatic Cylinders**

**SR/SRM, SRD/SRDM Series, Stainless Steel Body**

Features	C2-C3
Ordering Information	C3
Mounting Styles	C4
Specifications	C5
Technical Data	C6
Dimensional Data	C7-28
Air Reservoirs	C29
Options	C30
Adjustable Cushion Option	C31
Accessories	C32-C33



**SRG/SRGM Series with Stainless Caps**

Features	C34
Ordering Information	C34
Dimensional Data	C35
Mounting Style	C36
Accessories	C37



**SRX Series with Continuous Position Feedback**

Features	C38-C39
Ordering Information	C39
Mounting Styles	C40
Specifications	C40-C41
Dimensional Data	C42-C46
Accessories	C47
Connector Options	C48
Electrical Accessories	C49



**P1A Series - Mini ISO 6432, Stainless Steel**

Features	C50-C51
Ordering Information / Stroke Lengths	C51
Specifications	C52-C54
Dimensional Data	C55
Accessories	C56-C57



**P Series - Aluminum**

Features	C58-C59
Ordering Information	C59
Specifications	C60
Mountings	C60
Dimensional Data	C61-C65
Sensor Mounting / Service Kits	C66-C68





SR Series

**STAINLESS STEEL PISTON RODS**

Corrosion resistant stainless steel is now the standard piston rod material for all bore sizes up to and including 1.50 inch bore at no additional cost. The only exception to the stainless steel standard is when a hollow rod or non-rotating hexagonal rod option is specified. Stainless steel is also the standard material on block, trunnion and KDX mounts.

**PRE-LUBRICATION**

All SR Series cylinders are factory prelubricated for use with or without added lubrication.

**ROD BUSHINGS**

Oil impregnated bronze, reamed to a close tolerance provides for smooth operation and long life.

**SEALS**

All piston and rod seals are of a lipseal construction. Buna-N is standard on all models. Fluorocarbon seals are available as an option.

**PISTON BODY**

Pistons are precision machined aluminum construction. Piston rod connections are threaded and loctited to provide for leakproof and durable service.

**UNITIZED CONSTRUCTION**

Precision double-rolled unitized construction provides durable, leak-proof service and long life.



**HEADS AND CAPS**

Aluminum construction with precision machining provides a smooth break away. The tube-to-head connection is a strong double rolled construction.

**CYLINDER TUBE**

Type 304 stainless steel, polished to a micro-inch finish on the I.D. provides low friction and long life. A matte finish on the O.D. provides smudge resistance.

**TWELVE BORE SIZES** – 5/16" thru 3". SR Series cylinders are designed to be dimensionally interchangeable with other major stainless steel cylinders.

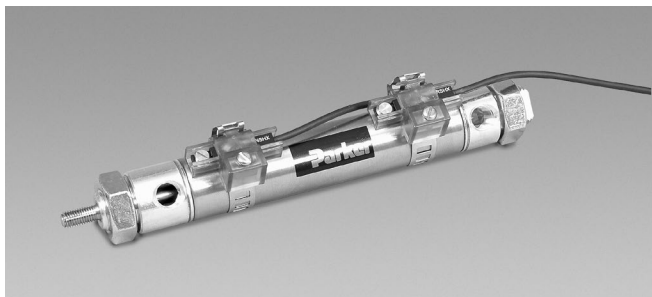

SRM Series

The SRM Series air cylinder can be ordered with reed or solid state sensors that are easily adjustable anywhere on the cylinder body, with no special mounting rail required. Nitrile-barium particle composite surrounds the entire piston diameter for non-contact sensing.

Sensors are compatible with Programmable Controllers; an LED indicator is also standard. A shielded cable is standard, and can be extended to 32 feet maximum by the user.



SRD/SRDM Series

SRD/SRDM Series cylinders are designed to withstand a wide range of operating environments to tolerate moisture and many types of lubricants and solvents. The cylinders have a acetal resin head and cap, an anodized aluminum piston, stainless steel cylinder tube and stainless steel piston rod. Stainless steel accessories are available.



Round Body  
Pneumatic Cylinders

SR/SRM/SRD/SRDM  
Series

SRG/SRGM  
Series

SRX  
Series

P1A  
Series

P  
Series



For inventory, lead times, and kit lookup, visit [www.pdnplu.com](http://www.pdnplu.com)

**Features**

- 304 stainless steel cylinder body, non repairable construction
- Aluminum heads and caps, acetal resin heads and caps are optional
- 12 bore sizes — 5/16" through 3" (see dimensional tables for SRM and SRD/SRDM exclusions).
- Stainless steel piston rods are standard up to 1.50" bore
- 28 standard mounting styles (not all available on SRM and SRD/SRDM – see table on following page)
- Single and double acting
- Adjustable cushions optional on both ends



**Operating information**

Operating pressure: 250 PSIG (17 bar) for SR and SRM  
100 PSIG (7 bar) for SRD/SRDM

Temperature range: -10°F to 165°F (-23°C to 74°C) for SR  
14°F to 140°F (-10°C to 60°C) for SRM  
32°F to 160°F (0°C to 71°C) for SRD/SRDM

Filtration requirements: 40 micron, dry filtered air

**Ordering information**

<b>1.06</b>	<b>C</b>	<b>D</b>	<b>SR</b>	<b>B</b>	<b>V</b>	<b>C</b>	<b>2.00</b>																																																						
<table border="1"> <tr><th colspan="2">Bore Size <sup>1,6</sup></th></tr> <tr><td>.31</td><td>5/16"</td></tr> <tr><td>.44</td><td>7/16"</td></tr> <tr><td>.56</td><td>9/16"</td></tr> <tr><td>.75</td><td>3/4"</td></tr> <tr><td>.88</td><td>7/8"</td></tr> <tr><td>1.06</td><td>1-1/16"</td></tr> <tr><td>1.25</td><td>1-1/4"</td></tr> <tr><td>1.50</td><td>1-1/2"</td></tr> <tr><td>1.75</td><td>1-3/4"</td></tr> <tr><td>2.00</td><td>2"</td></tr> <tr><td>2.50</td><td>2-1/2"</td></tr> <tr><td>3.00</td><td>3"</td></tr> </table>	Bore Size <sup>1,6</sup>		.31	5/16"	.44	7/16"	.56	9/16"	.75	3/4"	.88	7/8"	1.06	1-1/16"	1.25	1-1/4"	1.50	1-1/2"	1.75	1-3/4"	2.00	2"	2.50	2-1/2"	3.00	3"	<table border="1"> <tr><th colspan="2">Cushion Head <sup>2</sup></th></tr> <tr><td colspan="2">Use "C" only when cushion head is required.</td></tr> </table>	Cushion Head <sup>2</sup>		Use "C" only when cushion head is required.			<table border="1"> <tr><th colspan="2">Series</th></tr> <tr><td>SR</td><td>Standard Cylinder</td></tr> <tr><td>SRM</td><td>With Magnetic Piston <sup>6</sup></td></tr> <tr><td>SRD</td><td>With Acetal Resin Caps</td></tr> <tr><td>SRDM</td><td>With Acetal Resin Caps and Magnetic Piston <sup>6</sup></td></tr> </table>	Series		SR	Standard Cylinder	SRM	With Magnetic Piston <sup>6</sup>	SRD	With Acetal Resin Caps	SRDM	With Acetal Resin Caps and Magnetic Piston <sup>6</sup>	<table border="1"> <tr><th colspan="2">Piston</th></tr> <tr><td>Blank</td><td>No Bumpers</td></tr> <tr><td>B</td><td>With Bumpers <sup>3,8</sup></td></tr> </table>	Piston		Blank	No Bumpers	B	With Bumpers <sup>3,8</sup>		<table border="1"> <tr><th colspan="2">Cushion Cap <sup>2</sup></th></tr> <tr><td colspan="2">Use "C" only when cushion cap is required.</td></tr> </table>	Cushion Cap <sup>2</sup>		Use "C" only when cushion cap is required.		<table border="1"> <tr><th colspan="2">Stroke</th></tr> <tr><td colspan="2">Specify in inches.</td></tr> </table>	Stroke		Specify in inches.	
Bore Size <sup>1,6</sup>																																																													
.31	5/16"																																																												
.44	7/16"																																																												
.56	9/16"																																																												
.75	3/4"																																																												
.88	7/8"																																																												
1.06	1-1/16"																																																												
1.25	1-1/4"																																																												
1.50	1-1/2"																																																												
1.75	1-3/4"																																																												
2.00	2"																																																												
2.50	2-1/2"																																																												
3.00	3"																																																												
Cushion Head <sup>2</sup>																																																													
Use "C" only when cushion head is required.																																																													
Series																																																													
SR	Standard Cylinder																																																												
SRM	With Magnetic Piston <sup>6</sup>																																																												
SRD	With Acetal Resin Caps																																																												
SRDM	With Acetal Resin Caps and Magnetic Piston <sup>6</sup>																																																												
Piston																																																													
Blank	No Bumpers																																																												
B	With Bumpers <sup>3,8</sup>																																																												
Cushion Cap <sup>2</sup>																																																													
Use "C" only when cushion cap is required.																																																													
Stroke																																																													
Specify in inches.																																																													
<table border="1"> <tr><th colspan="2">Double Rod <sup>7</sup></th></tr> <tr><td colspan="2">Use "K" only when double rod is required. Available on DX and DXH mounting only.</td></tr> </table>	Double Rod <sup>7</sup>		Use "K" only when double rod is required. Available on DX and DXH mounting only.							<table border="1"> <tr><th colspan="2">Non-Standard Piston Rod</th></tr> <tr><td colspan="2">Use "3" only when special piston rod end is required. Specify CC, LE and A dimensions (see page C7).</td></tr> </table>	Non-Standard Piston Rod		Use "3" only when special piston rod end is required. Specify CC, LE and A dimensions (see page C7).																																																
Double Rod <sup>7</sup>																																																													
Use "K" only when double rod is required. Available on DX and DXH mounting only.																																																													
Non-Standard Piston Rod																																																													
Use "3" only when special piston rod end is required. Specify CC, LE and A dimensions (see page C7).																																																													
					<table border="1"> <tr><th colspan="2">Non-Standard Rod</th></tr> <tr><td colspan="2">Specify Y for stainless steel piston rod. Stainless steel is standard on all bore sizes up to and including 1.50" Bore and all SRD/ SRDM versions.</td></tr> </table>	Non-Standard Rod		Specify Y for stainless steel piston rod. Stainless steel is standard on all bore sizes up to and including 1.50" Bore and all SRD/ SRDM versions.																																																					
Non-Standard Rod																																																													
Specify Y for stainless steel piston rod. Stainless steel is standard on all bore sizes up to and including 1.50" Bore and all SRD/ SRDM versions.																																																													
					<table border="1"> <tr><th colspan="2">Special</th></tr> <tr><td colspan="2">Use "S" only if special modifications are required, except piston rod end (see page C7).</td></tr> </table>	Special		Use "S" only if special modifications are required, except piston rod end (see page C7).																																																					
Special																																																													
Use "S" only if special modifications are required, except piston rod end (see page C7).																																																													
					<table border="1"> <tr><th colspan="2">Seals</th></tr> <tr><td>Blank</td><td>Standard Seals</td></tr> <tr><td>V</td><td>Fluorocarbon Seals <sup>4</sup></td></tr> <tr><td>W</td><td>Rod Wiper <sup>9</sup></td></tr> </table>	Seals		Blank	Standard Seals	V	Fluorocarbon Seals <sup>4</sup>	W	Rod Wiper <sup>9</sup>																																																
Seals																																																													
Blank	Standard Seals																																																												
V	Fluorocarbon Seals <sup>4</sup>																																																												
W	Rod Wiper <sup>9</sup>																																																												
						<table border="1"> <tr><th colspan="2">Sensors</th></tr> <tr><td colspan="2">See section L for sensors.</td></tr> </table> 	Sensors		See section L for sensors.																																																				
Sensors																																																													
See section L for sensors.																																																													

<sup>1</sup> Bore sizes and mounting styles are limited by series. See table on next page for availability.

<sup>2</sup> Cushions not available on SRD/SRDM series, only available on D, DP, DXP mounts, reference page C31.

<sup>3</sup> Bumpers may increase cylinder length. Please reference page C30 for adders.

<sup>4</sup> Fluorocarbon seals only available on SRM/SRDM series for chemical compatibility, not high heat.

<sup>6</sup> Magnet not available on bore sizes .31, .44, .88

<sup>7</sup> Not available with cushions.

<sup>8</sup> Not available on bore size 3.0

<sup>9</sup> Not available on bore sizes .31, .44 and .56

For ordering purposes, when special options or common modifications are requested, the factory will assign a sequential part number in place of the model number.



For inventory, lead times, and kit lookup, visit [www.pdnplu.com](http://www.pdnplu.com)

C  
 Round Body  
 Pneumatic Cylinders  
 SR/SRM/SRD/SRDM  
 Series  
 SRG/SRGM  
 Series  
 SRX  
 Series  
 P1A  
 Series  
 P  
 Series

**Available Mounting Styles**

Mount Style	Description	Bore Size (Reference Notes 1 & 2 for availability)											Max. Stroke (in.)	
		5/16" (1,2)	7/16" (1,2)	9/16"	3/4"	7/8" (1,2)	1-1/16"	1-1/4" (2)	1-1/2" (2)	1-3/4" (2)	2" (2)	2-1/2" (2)		3" (1,2)
N <sup>(2)</sup>	Nose Mount, Spring Return	●	●	●	●	●	●	●	●	●	▲	—	—	6" <sup>(3)</sup>
NR <sup>(2)</sup>	Nose Mount, Spring Return, Hex Rod (Non-Rotating)	—	●	●	●	●	●	●	●	●	—	—	—	6"
NRP <sup>(2)</sup>	Pivot And Nose Mount, Spring Return, Hex Rod (Non-Rotating)	—	●	●	●	●	●	●	●	●	—	—	—	6"
P <sup>(2)</sup>	Pivot Mount, Spring Return	●	●	●	●	●	●	●	●	●	▲	—	—	6"
R <sup>(2)</sup>	Nose Mount, Spring Extended	●	●	●	●	●	●	●	●	●	▲	—	—	6"
RP <sup>(2)</sup>	Pivot And Nose Mount, Spring Extend	●	●	●	●	●	●	●	—	▲	—	—	—	6"
D	Nose Mount, Double Acting	●	●	●	●	●	●	●	●	●	●	●	●	12"
DP <sup>(2)</sup>	Pivot And Nose Mount, Double Acting, Pivot Pin	—	●	—	●	—	●	—	●	—	—	—	—	12"
DXP	Pivot And Nose Mount, Double Acting, No Pivot Pin	●	●	●	●	●	●	●	●	●	●	●	●	See Note 4
DX	Threaded Both Ends, Double Acting	—	See DXP	See DXP	See DXP	See DXP	See DXP	See DXP	●	—	See DXP	—	—	32"
KDX	Threaded Both Ends, Double Acting, Double Rod	—	●	●	●	●	●	●	●	●	●	●	●	See Note 5
KDXH <sup>(2)</sup>	Threaded Both Ends, Double Rod, Hollow Rod	—	—	—	—	—	●	●	●	—	—	—	—	12"
A <sup>(1,2)</sup>	Nose Mount, Spring Return, Head Adjustable Stroke	—	—	—	●	—	●	—	●	—	—	—	—	6"
RA <sup>(1,2)</sup>	Nose Mount, Spring Extend, Cap Adjustable Stroke	—	—	—	●	—	●	—	●	—	—	—	—	6"
AP <sup>(1,2)</sup>	Pivot Mount, Spring Return, Head Adjustable Stroke	—	—	—	●	—	●	—	●	—	—	—	—	6"
AR <sup>(1,2)</sup>	Air Reservoirs	—	—	—	●	—	●	—	●	—	—	—	—	12"
BRN <sup>(2)</sup>	Rear Block Mount, Single Acting,	—	●	—	●	—	●	—	●	—	—	—	—	6"
BRR <sup>(2)</sup>	Rear Block Mount, Single Acting, Spring Return	—	—	—	●	—	●	—	●	—	—	—	—	6"
BFD <sup>(2)</sup>	Front Block Mount, Double Acting	●	●	—	●	—	●	—	●	—	—	—	—	12"
BRD <sup>(2)</sup>	Rear Block Mount, Double Acting	—	●	—	●	—	●	—	●	—	—	—	—	12"
BFN <sup>(2)</sup>	Front Block Mount, Single Acting Spring Return	—	●	—	●	—	●	—	●	—	—	—	—	6"
BFR <sup>(2)</sup>	Front Block Mount, Single Acting Spring Extend	—	—	—	●	—	●	—	●	—	—	—	—	6"
TRN <sup>(2)</sup>	Rear Trunnion Mount, Single Acting, Spring Return	—	●	—	●	—	●	—	●	—	—	—	—	6"
TRR <sup>(2)</sup>	Rear Trunnion Mount, Single Acting Spring Extend	—	—	—	●	—	●	—	●	—	—	—	—	6"
TFD <sup>(2)</sup>	Front Trunnion Mount, Double Acting	—	●	—	●	—	●	—	●	—	—	—	—	12"
TRD <sup>(2)</sup>	Rear Trunnion Mount, Double Acting	—	●	—	●	—	●	—	●	—	—	—	—	12"
TFN <sup>(2)</sup>	Front Trunnion Mount, Single Acting Spring Return	—	●	—	●	—	●	—	●	—	—	—	—	6"
TFR <sup>(2)</sup>	Front Trunnion Mount, Single Acting Spring Extend	—	—	—	●	—	●	—	●	—	—	—	—	6"

- ▲ Recommended maximum stroke is 4" in models N, P, R & RP.
- 1 Not available on SRM (magnetic piston) cylinders.
- 2 Not available on SRD/DM (acetel resin caps) cylinders.
- 3 Recommended maximum stroke is 4" for 5/16" bore models.
- 4 Max stroke 12" for bore sizes under 3/4"; 32" for bore sizes 3/4" and up.
- 5 Max stroke 6" for bore sizes under 3/4"; 12" for bore sizes 3/4" and up.

**C**  
**Round Body Pneumatic Cylinders**  
**SR/SRM/SRD/SRDM Series**  
**SRG/SRGM Series**  
**SRX Series**  
**P1A Series**  
**P Series**



For inventory, lead times, and kit lookup, visit [www.pdnplu.com](http://www.pdnplu.com)

Specifications / Technical Data

Specifications

- 304 stainless steel cylinder body.
- Aluminum heads and caps.
- Stainless steel piston rods are standard up to 1.50" bore.
- Nominal pressure rating: 250 psi for SR and SRM  
100 psi for SRD/SRDM
- Standard temperature: -10°F to 165°F (SR)  
14°F to 140°F (SRM)  
32°F to 160°F (SRD/SRDM)  
-10°F to 250°F (Fluorocarbon seals)

In line with our policy of continuing product improvement, the specifications in this catalog are subject to change without notice.

- Twelve bore sizes — 5/16" through 3" (see table for SRD/SRDM or SRD/M exclusions).
- 28 standard mounting styles (not all available on SRM and SRD/SRDM – see table on previous page).
- Single and double acting
- Bumpers
- Adjustable cushions
- Rod wipers

For additional mounting styles please consult factory.

Port Locations

Mounting Style	Standard Head Port Location	Standard Cap Port Location	Standard Vent Location
AR	Face	Face	None
BFR	2	None	2
BFN	None	Face	2
BRD	2	2	None
BFD	2	Face	None
BRR	2	None	2
BRN	None	2	2
TFR	1	None	1
TFN	None	Face	1
TRD	1	1	None
TFD	1	Face	None
TRR	1	None	1
TRN	None	1	1
AP	None	2	2
RA	2	None	2
A	None	Face	2
KDXH	2	2	None
KDX	2	2	None
DX	2	2	None
DXP	2	2	None
DP	2	2	None
D	2	Face	None
RP	2	None	2
R	2	None	2
P	None	2	2
NRP	None	2	2
NR	None	Face	2
N	None	Face	2

End View of Mountings for Port Location

Mounting Styles N, NR, D, R, AR

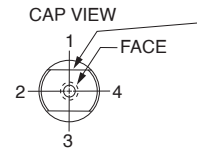

Standard location for cushion adjustment needle when cushions are specified on D mounts.

Mounting Styles P, RP, DXP, NRP, DP, AP

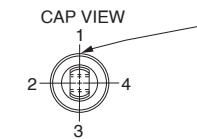

Standard location for cushion adjustment needle when cushions are specified on DXP mounts.

Mounting Style A

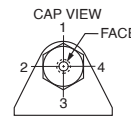

Mounting Style RA

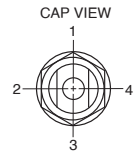

Mounting Styles BFD, BFN, BFR

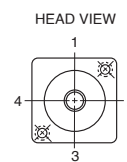

Mounting Styles BRN, BRR, BRD

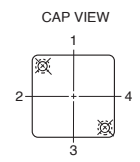

Mounting Styles KDXH, KDX

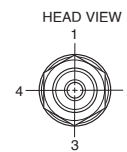

Mounting Style DX

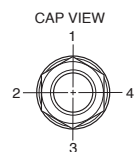

Mounting Styles TFD, TFN, TFR

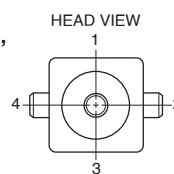

Mounting Styles TRN, TRR, TRD

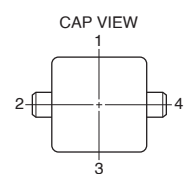

Cylinders will have ports at these locations unless otherwise specified.



Round Body  
Pneumatic Cylinders

SR/SRM/SRD/SRDM  
Series

SRG/SRGM  
Series

SRX  
Series

P1A  
Series

P  
Series



For inventory, lead times, and kit lookup, visit [www.pdnplu.com](http://www.pdnplu.com)

**Port Size – Rod Diameter, Spring Force Data**

Bore Size	Port Size	Rod Diameter (or Hex)	Force Factor		Spring Return (lbs)		Spring Extend (lbs)	
			Push	Pull	Normal	Extended	Normal	Retracted
.31 (5/16")	#10-32	1/8"	0.08	0.06	0.5	1	0.5	1
.44 (7/16")	#10-32	3/16"	0.15	0.12	1	2	1	2
.56 (9/16")	#10-32	3/16"	0.25	0.22	2	4	2	4
.75 (3/4")	1/8 NPTF	1/4"	0.44	0.39	3	6	3	6
.88 (7/8")	1/8 NPTF	1/4"	0.60	0.55	3	6	3	6
1.06 (1-1/16")	1/8 NPTF	5/16"	0.89	0.81	3†	6†	7.5	15
1.25 (1-1/4")	1/8 NPTF	7/16"	1.23	1.08	7.5	15	7.5	15
1.50 (1-1/2")	1/8 NPTF	7/16"	1.77	1.62	6†	12†	9	18
1.75 (1-3/4")	1/4 NPTF	1/2"	2.40	2.21	11	24	11	24
2.00 (2")	1/4 NPTF	5/8"	3.14	2.84	15	30	15	30
2.50 (2-1/2")	1/4 NPTF	5/8"	4.91	4.60	N/A	N/A	N/A	N/A
3.00 (3")	3/8 NPTF	3/4"	7.07	6.63	N/A	N/A	N/A	N/A

\* Non-rotating version uses 3/8" hex.  
 † Block mount and trunnion mount spring return lbs. equals spring extend lbs.

**Springs** — shot peened music wire for high cycle life. Spring spacers are provided for every one inch of stroke (1/2" for 5/16" and 7/16" bores) to insure uniform spring rate and prevent spring failure.

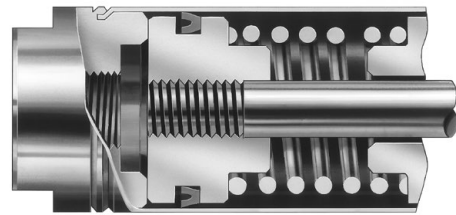

**Option Availability**

Option	Bumpers	Fluorocarbon Seals	Rod Wipers	Cushions	Acetal Resin end Caps
Bumpers	—	◆	◆	X	◆
Fluorocarbon Seals	—	—	X	S	◆
Rod Wiper	—	—	—	◆	◆
Cushions	—	—	—	—	X

◆ = Available Options  
 S = Available as Special  
 X = Not Available

**C**  
 Round Body Pneumatic Cylinders  
 SR/SRM/SRD/SRDM Series  
 SRG/SRGM Series  
 SRX Series  
 P1A Series  
 P Series



For inventory, lead times, and kit lookup, visit [www.pdnplu.com](http://www.pdnplu.com)

**Non-Standard Rods, Mounting Style – N**

**Non-Standard Rods**

For non-standard rod dimensions, or undersized rod end threads, put a "3" in model number and describe the rod using the letters shown in the drawing. Specify CC, LE and A dimensions. LE is measured in retracted position.

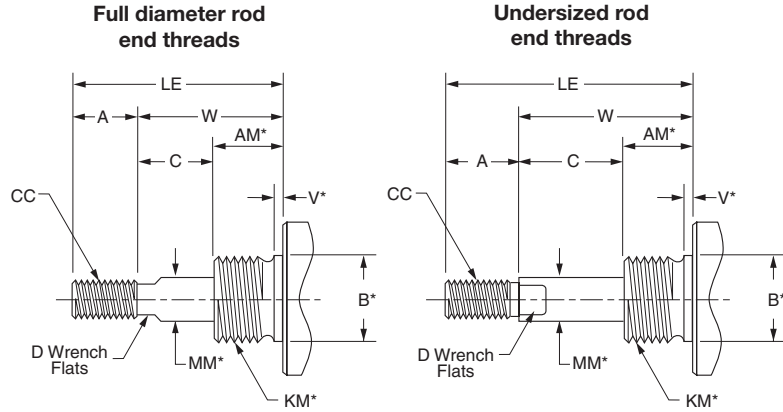

\* Requires an S designation in model number.

**Style N**

**Nose mount, spring return**

Bore Size	SR	SRM	Std. Stroke (in)	Max. Stroke (in)	SS Rod Std
5/16"	•		1/2, 1, 1-1/2, 2, 2-1/2, 3, 4	4	✓
7/16"	•		1/2, 1, 1-1/2, 2, 2-1/2, 3, 4	6	✓
9/16"	•	•	1/2, 1, 1-1/2, 2, 3, 4	6	✓
3/4"	•	•	1/2, 1, 1-1/2, 2, 3, 4	6	✓
7/8"	•		1/2, 1, 1-1/2, 2, 3, 4	6	✓
1-1/16"	•	•	1/2, 1, 1-1/2, 2, 3, 4	6	✓
1-1/4"	•	•	1/2, 1, 2, 3, 4	6	✓
1-1/2"	•	•	1/2, 1, 2, 3, 4	6	✓
1-3/4"	•	•	1/2, 1, 1-1/2, 2, 2-1/2, 3, 4	6	✓
2"	•	•	-	4	

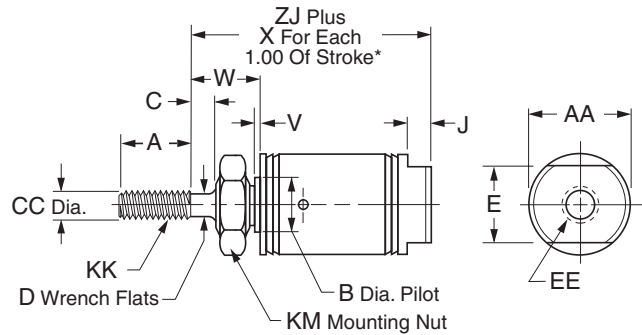

Bore Size															SR	SRM
	A	AA	B	C	CC	D	E	EE	J	KK	KM	V	W	X	ZJ	ZJ
5/16"	0.38	0.36	-	-	0.125	-	0.36	#10-32	-	#5-40 UNC	1/4-28	0	0.25	0.75**	1.12	-
7/16"	0.50	0.50	0.374	-	0.188	-	0.38	#10-32	0.19	#10-32 UNF	3/8-24	0.05	0.31	0.94**	1.31	-
9/16"	0.50	0.62	0.437	-	0.188	-	0.50	#10-32	0.19	#10-32 UNF	7/16-20	0.06	0.38	1.62	1.53	1.76
3/4"	0.50	0.81	0.499	-	0.250	-	0.62	1/8 NPTF	0.19	1/4-28 UNF	1/2-20	0.09	0.44	1.69	1.50	1.75
7/8"	0.50	0.93	0.624	-	0.250	-	0.62	1/8 NPTF	0.19	1/4-28 UNF	5/8-18	0.09	0.50	1.56	1.84	-
1-1/16"	0.50	1.12	0.624	0.12	0.312	0.25	0.88	1/8 NPTF	0.19	5/16-24 UNF	5/8-18	0.09	0.62	1.56	2.06	2.31
1-1/4"	0.75	1.34	0.749	0.25	0.437	0.38	0.88	1/8 NPTF	0.25	7/16-20 UNF	3/4-16	0.09	0.88	1.81	2.66	2.78
1-1/2"	0.75	1.56	0.749	0.25	0.437	0.38	0.88	1/8 NPTF	0.25	7/16-20 UNF	3/4-16	0.09	0.88	1.69	2.44	2.69
1-3/4"	0.88	1.84	1.031	0.31	0.500	7/16	1.25	1/4 NPTF	0.25	1/2-20 UNF	1-14	0.09	1.06	2.0	2.97	3.22
2"	0.88	2.08	1.374	0.38	0.625	0.50	1.25	1/4 NPTF	0.31	1/2-20 UNF	1-1/4 †	0.12	1.19	-	▲	▲

▲ SR: 5.41" for 1" stroke, 7.41" for 2" stroke, 8.66" for 3" stroke, 11.59" for 4" stroke.  
SRM: 5.66" for 1" stroke, 7.66" for 2" stroke, 8.91" for 3" stroke, 11.84" for 4" stroke.

\* To determine lengths for half inch stroke increments, determine length for next highest whole number stroke and subtract a half inch.

\*\* For each 0.50" of stroke

† No mounting nut



For inventory, lead times, and kit lookup, visit [www.pdnplu.com](http://www.pdnplu.com)

**Style NR**

Nose mount, spring return, hex rod

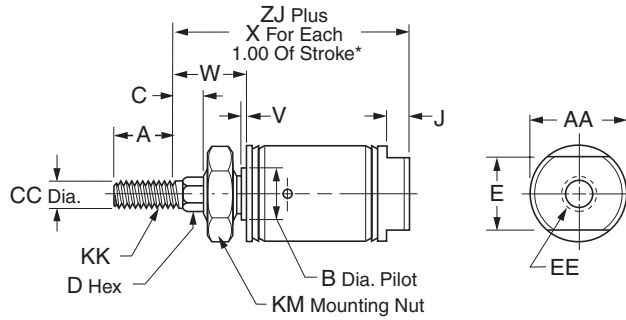

Bore Size	SR	SRM	Std. Stroke (in)	Max. Stroke (in)	SS Rod Std
7/16"	•		1/2, 1, 1-1/2, 2, 3, 4	6	✓
9/16"	•	•	1/2, 1, 1-1/2, 2, 3, 4	6	✓
3/4"	•	•	1/2, 1, 1-1/2, 2, 3, 4	6	✓
7/8"	•		1/2, 1, 1-1/2, 2, 3, 4	6	✓
1-1/16"	•	•	1/2, 1, 1-1/2, 2, 3, 4	6	✓
1-1/4"	•	•	1, 2, 3, 4	6	✓
1-1/2"	•	•	1/2, 1, 2, 3, 4	6	✓
1-3/4"	•	•	1/2, 1, 1-1/2, 2, 2-1/2, 3, 4	6	

Bore Size	A	AA	B	C	CC	D	E	EE	J	KK	KM	V	W	X	SR ZJ	SRM ZJ
7/16"	0.50	-	0.374	0.25	0.188	3/16	-	#10-32	0.19	#10-32 UNF	3/8-24	0.05	0.56	0.94	1.56	-
9/16"	0.50	-	0.437	0.25	0.188	3/16	-	#10-32	0.19	#10-32 UNF	7/16-20	0.06	0.62	1.62	1.78	2.03
3/4"	0.50	-	0.499	0.25	0.250	1/4	-	1/8 NPTF	0.19	1/4-28 UNF	1/2-20	0.09	0.69	1.69	1.75	2.00
7/8"	0.50	-	0.624	0.25	0.250	1/4	-	1/8 NPTF	0.19	1/4-28 UNF	5/8-18	0.09	0.75	1.56	2.09	-
1-1/16"	0.50	1.12	0.624	0.25	0.312	3/8	0.88	1/8 NPTF	0.19	5/16-24 UNF	5/8-18	0.09	0.75	1.56	2.19	2.44
1-1/4"	0.88	1.34	0.749	0.25	0.437	7/16	0.88	1/8 NPTF	0.25	7/16-20 UNF	3/4-16	0.09	0.88	1.81	2.66	2.78
1-1/2"	0.88	1.56	0.749	0.38	0.437	7/16	0.88	1/8 NPTF	0.25	7/16-20 UNF	3/4-16	0.09	1.00	1.69	2.56	2.81
1-3/4"	0.88	1.84	1.031	0.38	0.500	1/2	1.25	1/4 NPTF	0.25	1/2-20 UNF	1-14	0.09	1.12	2.0	3.03	3.28

\* To determine lengths for half inch stroke increments, determine length for next highest whole number stroke and subtract one half inch.



For inventory, lead times, and kit lookup, visit [www.pdnplu.com](http://www.pdnplu.com)



**Style NRP**

Pivot & nose mount, spring return, hex rod

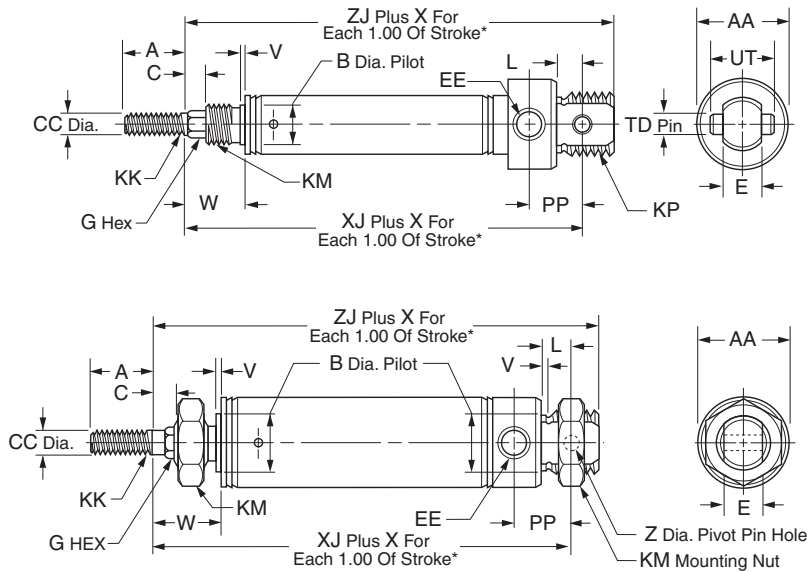

**Bore Sizes**

7/16" *
3/4"

\* No mounting nuts

**Bore Sizes**

9/16" *
7/8" *
1-1/16" *
1-1/4"
1-1/2" *
1-3/4"

\* No mounting nuts

Bore Size	SR	SRM	Std. Stroke (in)	Max. Stroke (in)	SS Rod Std	A	AA	B	C	CC	E	EE
7/16"	•		1/2, 1, 1-1/2, 2, 3, 4	6	✓	0.50	0.74	0.374	0.25	0.188	0.31	#10-32
9/16"	•	•	1/2, 1, 1-1/2, 2, 3, 4	6	✓	0.50	0.62	0.437	0.25	0.188	0.31	#10-32
3/4"	•	•	1, 2, 3, 4	6	✓	0.50	0.86	0.499	0.25	0.250	0.38	1/8 NPTF
7/8"	•		1, 2, 3, 4	6	✓	0.50	0.93	0.624	0.25	0.250	0.38	1/8 NPTF
1-1/16"	•	•	1, 2, 3, 4	6	✓	0.50	1.12	0.624	0.25	0.312	0.38	1/8 NPTF
1-1/4"	•	•	1, 2, 3, 4	6	✓	0.88	1.34	0.749	0.25	0.437	0.50	1/8 NPTF
1-1/2"	•	•	1, 2, 3, 4	6	✓	0.88	1.56	0.749	0.38	0.437	0.62	1/8 NPTF
1-3/4"	•	•	1/2, 1, 1-1/2, 2, 2-1/2, 3, 4	6		0.88	1.84	1.031	0.38	0.500	0.62	1/4 NPTF

Bore Size	SR		SRM		L	PP	TD	UT	V	W	X	SR			SRM	
	G HEX	KK	KM	KP								Z	ZJ	ZJ		
7/16"	3/16	#10-32 UNF	3/8-24	7/16-20 UNF	0.25	0.44	0.156	0.50	0.05	0.56	0.94	2.00	-	-	2.25	-
9/16"	3/16	#10-32 UNF	7/16-20	7/16-20 UNF	0.25	0.38	-	-	0.06	0.62	1.62	2.06	2.31	0.157	2.25	2.50
3/4"	1/4	1/4-28 UNF	1/2-20	5/8-18 UNF	0.34	0.62	0.250	0.75	0.09	0.69	1.69	2.53	2.78	-	2.81	3.06
7/8"	1/4	1/4-28 UNF	5/8-18	5/8-18 UNF	0.34	0.62	0.250	0.75	0.09	0.75	1.56	2.72	-	-	3.00	-
1-1/16"	3/8	5/16-24 UNF	5/8-18	5/8-18 UNF	0.34	0.62	0.250	0.75	0.09	0.75	1.56	2.78	3.03	-	3.06	3.31
1-1/4"	7/16	7/16-20 UNF	3/4-16	-	0.41	0.78	0.251	-	0.09	0.88	1.81	3.38	3.50	0.251	3.78	3.91
1-1/2"	7/16	7/16-20 UNF	3/4-16	-	0.50	0.77	0.375	1.00	0.09	1.00	1.69	3.25	3.50	-	3.62	3.87
1-3/4"	1/2	1/2-20 UNF	1-14	-	0.50	1.12	-	-	0.09	1.12	2.0	4.09	4.34	0.376	4.59	4.84

\* To determine lengths for half inch stroke increments, determine length for next highest whole number stroke and subtract one half inch.



For inventory, lead times, and kit lookup, visit [www.pdnplu.com](http://www.pdnplu.com)



Round Body  
 Pneumatic Cylinders

SR/SRM/SRD/SRDM  
 Series

SRG/SRGM  
 Series

SRX  
 Series

P1A  
 Series

P  
 Series

Mounting Style – P

Style P

Pivot mount, spring return

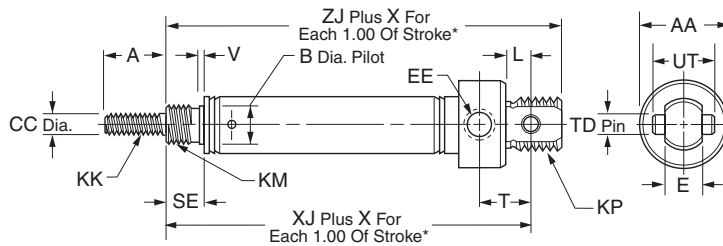

Bore Sizes

- 5/16" \*
- 7/16"
- 3/4"

\* No mounting nuts

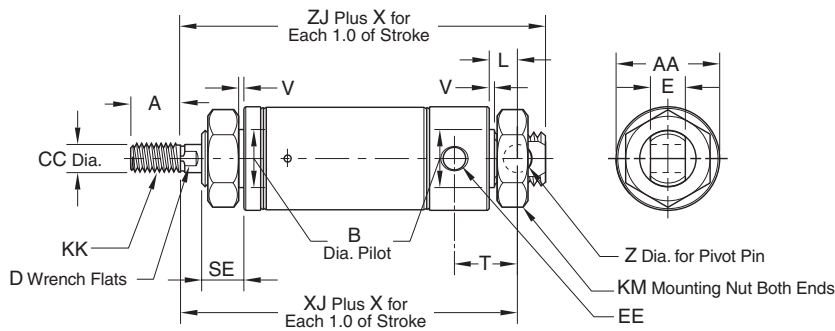

Bore Sizes

- 9/16" \*
- 7/8" \*
- 1-1/16" \*
- 1-1/4"
- 1-1/2" \*
- 1-3/4"
- 2" \*

\* No mounting nuts

Bore Size	SR	SRM	Std. Stroke (in)	Max. Stroke (in)	SS Rod Std	A	AA	B	CC	D	E	EE
5/16"	•		1/2, 1, 1-1/2, 2, 3, 4	4	✓	0.38	0.39	-	0.125	-	0.25	#10-32
7/16"	•		1/2, 1, 1-1/2, 2, 3, 4	6	✓	0.50	0.74	0.374	0.188	-	0.31	#10-32
9/16"	•	•	1/2, 1, 1-1/2, 2, 3, 4	6	✓	0.50	0.62	0.437	0.188	-	0.31	#10-32
3/4"	•	•	1/2, 1, 1-1/2, 2, 3, 4	6	✓	0.50	0.86	0.499	0.250	-	0.38	1/8 NPTF
7/8"	•		1/2, 1, 1-1/2, 2, 3, 4	6	✓	0.50	0.93	0.624	0.250	-	0.38	1/8 NPTF
1-1/16"	•	•	1/2, 1, 1-1/2, 2, 3, 4	6	✓	0.50	1.12	0.624	0.312	0.25	0.38	1/8 NPTF
1-1/4"	•	•	1, 2, 3, 4	6	✓	0.75	1.34	0.749	0.437	0.38	0.50	1/8 NPTF
1-1/2"	•	•	1, 2, 3, 4	6	✓	0.75	1.56	0.749	0.437	0.38	0.62	1/8 NPTF
1-3/4"	•	•	1/2, 1, 1-1/2, 2, 2-1/2, 3, 4	6		0.88	1.84	1.031	0.500	7/16	0.62	1/4 NPTF
2"	•	•	-	4		0.88	2.08	1.374	0.625	0.50	0.75	1/4 NPTF

Bore Size	KK	KM	KP	L	SE	T	TD	UT	V	X	SR XJ	SRM XJ	Z	SR ZJ	SRM ZJ
5/16"	#5-40 UNC	3/8-24	-	0.34	0.25	0.34	-	-	-	0.75	1.52	-	0.125	1.68	-
7/16"	#10-32 UNF	3/8-24	7/16-20 UNF	0.25	0.31	0.44	0.156	0.50	0.05	0.94	1.75	-	-	2.00	-
9/16"	#10-32 UNF	7/16-20	7/16-20 UNF	0.25	0.38	0.38	-	-	0.06	1.62	1.81	2.06	0.157	2.00	2.25
3/4"	1/4-28 UNF	1/2-20	5/8-18 UNF	0.34	0.44	0.62	0.250	0.75	0.09	1.69	2.28	2.53	-	2.56	2.81
7/8"	1/4-28 UNF	5/8-18	5/8-18 UNF	0.34	0.50	0.62	0.250	0.75	0.09	1.56	2.47	-	-	2.75	-
1-1/16"	5/16-24 UNF	5/8-18	5/8-18 UNF	0.34	0.50	0.62	0.250	0.75	0.09	1.56	2.66	2.91	-	2.94	3.19
1-1/4"	7/16-20 UNF	3/4-16	-	0.41	0.63	0.78	-	-	0.09	1.81	3.38	3.91	0.251	3.78	3.50
1-1/2"	7/16-20 UNF	3/4-16	-	0.50	0.63	0.77	0.375	1.00	0.09	1.81	3.12	3.37	-	3.50	3.75
1-3/4"	1/2-20 UNF	1-14	-	0.50	0.75	1.12	-	-	0.09	2.0	4.03	4.28	0.376	4.53	4.78
2"	1/2-20 UNF	1-1/4-12	-	0.56	0.81	1.03	-	-	0.12	-	■	*	-	▲	◆

- 6.34" for 1" stroke, 8.34" for 2" stroke, 9.59" for 3" stroke, 12.53" for 4" stroke\*
- ▲ 6.78" for 1" stroke, 8.78" for 2" stroke, 10.03" for 3" stroke, 12.97" for 4" stroke\*
- \* 6.59" for 1" stroke, 8.59" for 2" stroke, 9.84" for 3" stroke, 12.78" for 4" stroke\*
- ◆ 7.03" for 1" stroke, 9.03" for 2" stroke, 10.28" for 3" stroke, 13.22" for 4" stroke\*

\* To determine lengths for half inch stroke increments, determine length for next highest whole number stroke and subtract a half inch.



For inventory, lead times, and kit lookup, visit [www.pdnplu.com](http://www.pdnplu.com)

C10

Parker Hannifin Corporation  
Pneumatic Division  
Wadsworth, Ohio  
[www.parker.com/pneumatics](http://www.parker.com/pneumatics)

Mounting Style – R

Style R

Nose mount, spring extended

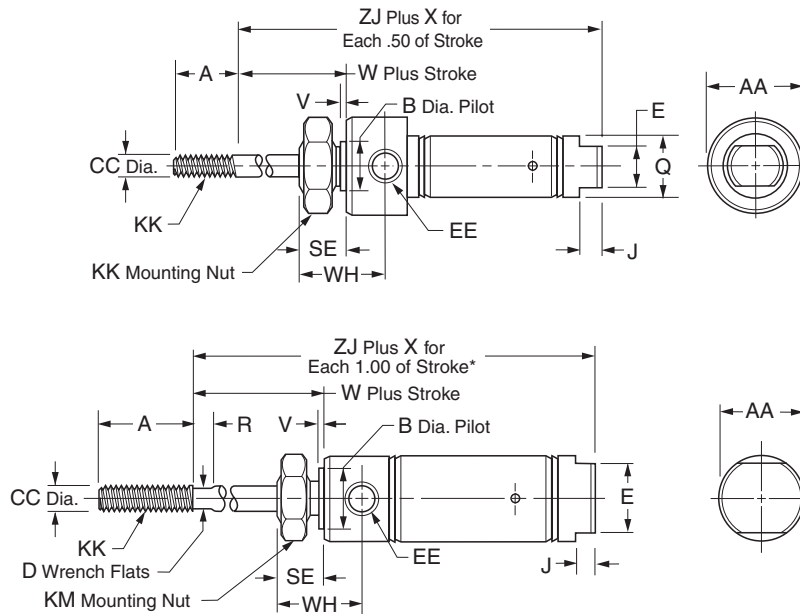

Bore Sizes
5/16"
7/16"
3/4"

Bore Sizes
9/16"
7/8"
1-1/16"
1-1/4"
1-1/2"
1-3/4"
2" *

\* No mounting nuts

Bore Size	SR	SRM	Std. Stroke (in)	Max. Stroke (in)	SS Rod Std	A	AA	B	CC	D	E
5/16"	•		1/2, 1, 1-1/2, 2, 2-1/2, 3	4	✓	0.38	0.50 SQ.	-	0.125	-	-
7/16"	•		1/2, 1, 1-1/2, 2, 3	6	✓	0.50	0.74	0.437	0.188	-	0.38
9/16"	•	•	1/2, 1, 1-1/2, 2, 3	6	✓	0.50	0.62	0.437	0.188	-	0.50
3/4"	•	•	1/2, 1, 2, 3, 4	6	✓	0.50	0.86	0.624	0.250	-	-
7/8"	•		1/2, 1, 2, 3, 4	6	✓	0.50	0.93	0.624	0.250	-	-
1-1/16"	•	•	1/2, 1, 1-1/2, 2, 3, 4	6	✓	0.50	1.12	0.624	0.312	0.25	-
1-1/4"	•	•	1, 2, 3, 4	6	✓	0.75	1.34	0.749	0.437	0.38	-
1-1/2"	•	•	1, 2, 3, 4	6	✓	1.25	1.56	0.749	0.437	0.38	0.88
1-3/4"	•	•	1/2, 1, 1-1/2, 2, 2-1/2, 3, 4	6		0.88	1.84	1.031	0.500	7/16	-
2"	•	•	-	4		0.88	2.08	1.374	0.625	0.50	-

Bore Size	EE	J	KK	KM	Q	R	SE	V	W	WH	X	SR ZJ	SRM ZJ
5/16"	#10-32	-	#5-40 UNC	3/8-24	0.36	-	0.31	-	0.31	0.47	1.25	1.49	-
7/16"	#10-32	0.19	#10-32 UNF	7/16-20	0.50	-	0.38	0.05	0.38	0.72	1.44	1.94	-
9/16"	#10-32	0.19	#10-32 UNF	7/16-20	0.62	-	0.38	0.05	0.38	0.78	2.62	2.00	2.25
3/4"	1/8 NPTF	-	1/4-28 UNF	5/8-18	0.81	-	0.50	0.09	0.50	0.97	2.69**	2.31	2.56
7/8"	1/8 NPTF	-	1/4-28 UNF	5/8-18	-	-	0.50	0.09	0.50	0.97	2.56	2.31	-
1-1/16"	1/8 NPTF	-	5/16-24 UNF	5/8-18	-	0.12	0.50	0.09	0.62	1.06	2.81	2.62	2.87
1-1/4"	1/8 NPTF	-	7/16-20 UNF	3/4-16	-	0.25	0.62	0.09	0.88	1.38	2.81	3.47	3.60
1-1/2"	1/8 NPTF	0.25	7/16-20 UNF	3/4-16	-	0.25	0.62	0.09	0.88	1.25	3.00	3.19	3.44
1-3/4"	1/4 NPTF	-	1/2-20 UNF	1-14	-	-	0.75	0.09	1.06	1.63	3.0	4.03	4.28
2"	1/4 NPTF	-	1/2-20 UNF	1-1/4-12	-	0.38	0.81	0.12	1.19	1.50	-	▲	◆

▲ 7.11" for 1" stroke, 10.11" for 2" stroke, 12.34" for 3" stroke, 16.34" for 4" stroke.\*

◆ 7.36" for 1" stroke, 10.36" for 2" stroke, 12.59" for 3" stroke, 16.59" for 4" stroke\*

\* To determine lengths for half inch stroke increments, determine length for next highest whole number stroke and subtract one half inch.

\*\* For each 1.00" of stroke.



For inventory, lead times, and kit lookup, visit [www.pdnplu.com](http://www.pdnplu.com)

C  
 Round Body Pneumatic Cylinders  
 SR/SRM/SRD/SRDM Series  
 SRG/SRGM Series  
 SRX Series  
 P1A Series  
 P Series

Mounting Style – RP

Style RP

Pivot and nose mount, spring extended

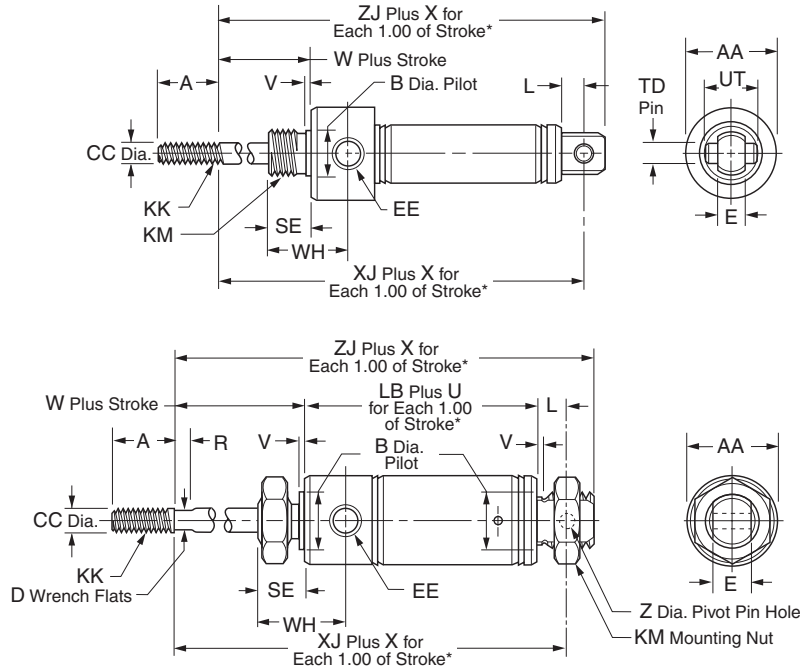

Bore Sizes
5/16" *
7/16"
3/4"

\* No mounting nuts

Bore Sizes
9/16" *
7/8" *
1-1/16" *
1-1/4"
1-1/2" *
1-3/4"
2" *

\* No mounting nuts

Bore Size	Series		Std. Stroke (in)	Max. Stroke (in)	SS Rod Std	Dimensions																		
	SR	SRM				A	AA	B	CC	D	E	EE	KK	LB	R	SE	TD	U	UT	V	W	WH	X	XJ
5/16"	•		1/2, 1, 1-1/2, 2, 2-1/2, 3	4	✓	0.38	0.50 SQ.	-	0.125	-	0.25	#10-32	#5-40 UNC											
7/16"	•		1/2, 1, 1-1/2, 2, 3	6	✓	0.50	0.74	0.437	0.188	-	0.31	#10-32	#10-32 UNF											
9/16"	•	•	1/2, 1, 1-1/2, 2, 3	6	✓	0.50	0.62	0.437	0.188	-	0.31	#10-32	#10-32 UNF											
3/4"	•	•	1/2, 1, 2, 3, 4	6	✓	0.50	0.86	0.624	0.250	-	0.38	1/8 NPTF	1/4-28 UNF											
7/8"	•		1/2, 1, 2, 3, 4	6	✓	0.50	0.93	0.624	0.250	-	0.38	1/8 NPTF	1/4-28 UNF											
1-1/16"	•	•	1/2, 1, 1-1/2, 2, 3, 4	6	✓	0.50	1.12	0.624	0.312	0.25	0.38	1/8 NPTF	5/16-24 UNF											
1-1/4"	•	•	1, 2, 3, 4	6	✓	0.75	1.34	0.749	0.437	0.38	0.50	1/8 NPTF	7/16-20 UNF											
1-1/2"	•	•	1, 2, 3, 4	6	✓	1.25	1.56	0.749	0.437	0.38	0.62	1/8 NPTF	7/16-20 UNF											
2"	•	•	-	4		.88	2.08	1.374	0.625	0.50	0.75	1/4 NPTF	1/2-20 UNF											

Bore Size	Series		Dimensions													SR	SRM	SR	SRM
	KM	L	LB	R	SE	TD	U	UT	V	W	WH	X	XJ	XJ	Z	ZJ	ZJ		
5/16"	3/8-24	0.19	-	-	0.31	-	-	-	-	0.31	0.47	1.25	1.88	-	-	2.04	-		
7/16"	7/16-20	0.25	-	-	0.38	0.156	-	0.50	0.05	0.38	0.72	1.44	2.38	-	-	2.62	-		
9/16"	7/16-20	0.25	-	-	0.38	-	-	-	0.06	0.38	0.78	2.62	2.28	2.53	0.157	2.47	2.72		
3/4"	5/8-18	0.34	-	-	0.50	0.250	-	0.75	0.09	0.50	0.97	2.69	2.44	2.69	-	2.72	2.97		
7/8"	5/8-18	0.34	-	-	0.50	0.250	-	0.75	0.09	0.50	0.97	2.56	2.63	-	-	2.91	-		
1-1/16"	5/8-18	0.34	-	0.12	0.50	0.250	-	0.75	0.09	0.62	1.06	2.81	2.78	3.03	-	3.06	3.31		
1-1/4"	3/4-16	0.41	2.47	0.25	0.62	-	1.81	-	0.09	0.88	1.38	2.81	3.78	3.91	0.251	4.16	4.28		
1-1/2"	3/4-16	0.50	-	0.25	0.62	0.375	-	1.00	0.09	0.88	1.25	3.00	3.88	4.13	-	4.25	4.50		
2"	1-1/4 -12	0.56	-	0.38	0.81	-	-	-	0.12	1.19	1.50	-	■	*	0.376	▲	◆		

- 8.05" for 1" stroke, 11.05" for 2" stroke, 13.28" for 3" stroke, 17.28" for 4" stroke\*
- ▲ 8.50" for 1" stroke, 11.50" for 2" stroke, 13.72" for 3" stroke, 17.72" for 4" stroke\*
- \* 8.31" for 1" stroke, 11.31" for 2" stroke, 13.53" for 3" stroke, 17.53" for 4" stroke\*
- ◆ 8.75" for 1" stroke, 11.75" for 2" stroke, 13.97" for 3" stroke, 17.97" for 4" stroke\*

\* To determine lengths for half inch stroke increments, determine length for next highest whole number stroke and subtract one half inch.



For inventory, lead times, and kit lookup, visit [www.pdnplu.com](http://www.pdnplu.com)

Mounting Style – D

Style D

Nose mount, double acting

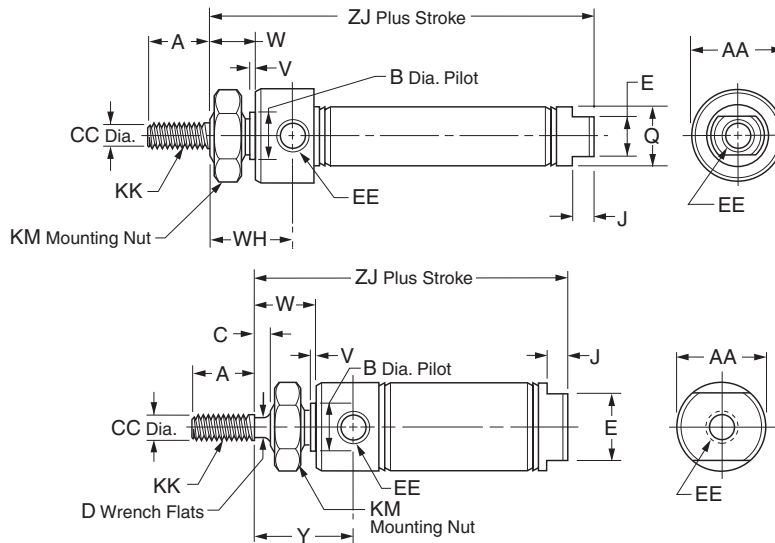

Bore Sizes

- 5/16"
- 7/16"
- 3/4"

Bore Sizes

- 9/16"
- 7/8"
- 1-1/16"
- 1-1/4"
- 1-1/2"
- 1-3/4"
- 2" \*
- 2-1/2" \*
- 3" \*

\* No mounting nuts

Bore Size	SR	SRM	SRD SRDM	Std. Stroke (in)	Max. Stroke (in)	SS Rod Std	A	AA	B	C	CC
5/16"	•			1/2, 1, 1-1/2, 2, 2-1/2, 3, 4	4	✓	0.38	0.50 SQ.	-	-	0.125
7/16"	•			1/2, 1, 1-1/2, 2, 3, 4	12	✓	0.50	0.74	0.437	-	0.188
9/16"	•	•	•	1/2, 1, 1-1/2, 2, 3, 4	12	✓	0.50	0.62	0.437	-	0.188
3/4"	•	•	•	1/2, 1, 2, 2-1/2, 3, 4, 5, 6, 8, 10	12	✓	0.50	0.86	0.624	-	0.250
7/8"	•			1/2, 1, 2, 3, 4, 5, 6	12	✓	0.50	0.93	0.624	-	0.250
1-1/16"	•	•	•	1/2, 1, 1-1/2, 2, 2-1/2, 3, 4, 5, 6, 8, 10, 12	12	✓	0.50	1.12	0.624	0.12	0.312
1-1/4"	•	•		1, 2, 3, 4, 5, 6	12	✓	0.75	1.34	0.749	0.25	0.437
1-1/2"	•	•	•	1/2, 1, 2, 3, 4, 5, 6, 8, 10, 12	12	✓	0.75	1.56	0.749	0.25	0.437
1-3/4"	•	•		1/2, 1, 1-1/2, 2, 2-1/2, 3, 4, 5, 6	12		0.88	1.84	1.031	0.31	0.500
2"	•	•	•	-	12		0.88	2.08	1.374	0.38	0.625
2-1/2"	•	•		-	12		0.88	2.62	1.500	0.38	0.625
3"	•			-	12		1.25	3.16	1.630	0.38	0.750

Bore Size	D	E	EE	J	KK	KM	Q	V	W	WH	Y	SR ZJ	SRM ZJ
5/16"	-	-	#10-32	-	#5-40 UNC	3/8-24	0.36	-	0.31	0.47	-	1.67	-
7/16"	-	0.38	#10-32	0.19	#10-32 UNF	7/16-20	0.50	0.05	0.38	0.72	-	2.12	-
9/16"	-	0.50	#10-32	0.19	#10-32 UNF	7/16-20	-	0.06	0.38	0.78	-	2.28	2.53
3/4"	-	0.62	1/8 NPTF	0.19	1/4-28 UNF	5/8-18	0.81	0.09	0.50	0.97	-	2.97	2.97
7/8"	-	0.62	1/8 NPTF	0.19	1/4-28 UNF	5/8-18	-	0.09	0.50	0.97	-	2.94	-
1-1/16"	0.25	0.88	1/8 NPTF	0.19	5/16-24 UNF	5/8-18	-	0.09	0.62	-	1.19	3.25	3.41
1-1/4"	0.38	0.88	1/8 NPTF	0.25	7/16-20 UNF	3/4-16	-	0.09	0.88	-	1.62	4.00	4.03
1-1/2"	0.38	0.88	1/8 NPTF	0.25	7/16-20 UNF	3/4-16	-	0.09	0.88	-	1.50	3.69	3.94
1-3/4"	7/16	1.25	1/4 NPTF	0.25	1/2-20 UNF	1-14	-	0.09	1.06	1.63	-	4.69	4.94
2"	0.50	1.25	1/4 NPTF	0.31	1/2-20 UNF	1-1/4-12	-	0.12	1.19	-	1.88	4.69	4.97
2-1/2"	1/2	1.75	1/4 NPTF	0.31	1/2-20 UNF	1-3/8-12	-	0.13	1.19	-	1.84	4.69	4.69
3"	5/8	2.00	3/8 NPTF	0.31	5/8-18 UNF	1-1/2-12	-	0.19	1.38	-	2.09	5.25	-



For inventory, lead times, and kit lookup, visit [www.pdnplu.com](http://www.pdnplu.com)



Round Body  
Pneumatic Cylinders

SR/SRM/SRD/SRDM  
Series

SRG/SRGM  
Series

SRX  
Series

P1A  
Series

P  
Series

Mounting Style – DP

Style DP

Pivot and nose mount, double acting, pivot pin

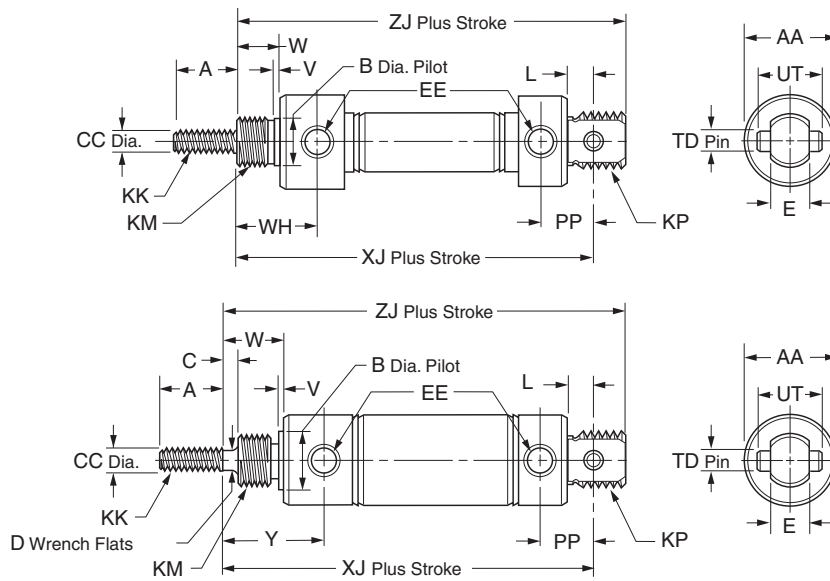

Bore Sizes

- 5/16"
- 7/16"
- 3/4"

Bore Sizes

- 1-1/16"
- 1-1/2"

**C**  
 Round Body  
 Pneumatic Cylinders  
 SR/SRM/SRD/SRDM  
 Series  
 SRG/SRGM  
 Series  
 SRX  
 Series  
 P1A  
 Series  
 P  
 Series

Bore Size	SR	SRM	Std. Stroke (in)	Max. Stroke (in)	SS Rod	A	AA	B	CC	D	E
7/16"	•		1/2, 1, 1-1/2, 2, 3, 4	12	✓	0.50	0.74	0.437	0.188	-	0.31
3/4"	•	•	1/2, 1, 2, 2-1/2, 3, 4, 5, 6, 8, 10	12	✓	0.50	0.86	0.624	0.250	-	0.38
1-1/16"	•	•	1/2, 1, 1-1/2, 2, 2-1/2, 3, 4, 5, 6, 8, 10, 12	12	✓	0.50	1.12	0.624	0.312	0.25	0.38
1-1/2"	•	•	1, 2, 3, 4, 5, 6, 8, 10, 12	12	✓	0.75	1.56	0.749	0.437	0.38	0.62

Bore Size	EE	KK	KM	KP	L	PP	TD	UT	V	W	WH	SR XJ	SRM XJ	Y	SR ZJ	SRM ZJ
7/16"	#10-32	#10-32 UNF	7/16-20	7/16-20 UNF	0.25	0.44	0.156	0.50	0.05	0.38	0.72	2.56	-	-	2.81	-
3/4"	1/8 NPTF	1/4-28 UNF	5/8-18	5/8-18 UNF	0.34	0.62	0.250	0.75	0.09	0.50	0.97	3.75	3.75	-	4.03	4.03
1-1/16"	1/8 NPTF	5/16-24 UNF	5/8-18	5/8-18 UNF	0.34	0.62	0.250	0.75	0.09	0.62	-	3.84	4.00	1.19	4.12	4.28
1-1/2"	1/8 NPTF	7/16-20 UNF	3/4-16	-	0.50	0.77	0.375	1.00	0.09	0.87	-	4.38	4.63	1.50	4.75	5.00



For inventory, lead times, and kit lookup, visit [www.pdnplu.com](http://www.pdnplu.com)

Mounting Style – DXP

Style DXP

Pivot & nose mount, double acting, no pivot pin

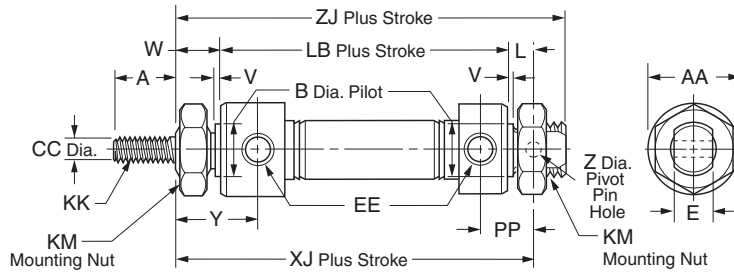

Bore Sizes

- 5/16"
- 7/16"
- 3/4"

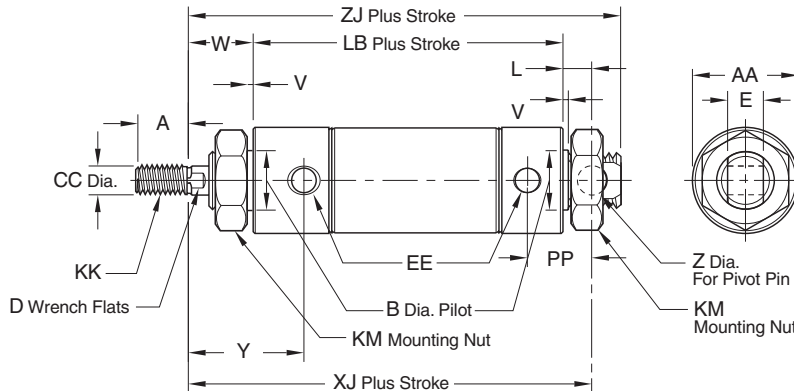

Bore Sizes

- 9/16" \*
- 7/8"
- 1-1/16"
- 1-1/4"
- 1-1/2"
- 1-3/4"
- 2" \*
- 2-1/2" \*
- 3" \*

\* No mounting nuts

Bore Size	SR	SRM	SRD SRDM	Std. Stroke (in)	Max. Stroke (in)	SS Rod Std	A	AA	B	CC	D	E
5/16"	•			1/2, 1, 1-1/2, 2, 2-1/2, 3, 4	4	✓	0.38	0.50 SQ.	-	0.125	-	0.25
7/16"	•			1/2, 1, 1-1/2, 2, 3, 4	12	✓	0.50	0.74	0.437	0.188	-	0.31
9/16"	•	•	•	1/2, 1, 1-1/2, 2, 3, 4	12	✓	0.50	0.62	0.437	0.188	-	0.31
3/4"	•	•	•	1, 2, 3, 4, 5, 6, 8, 10	32	✓	0.50	0.86	0.624	0.250	-	0.38
7/8"	•			1, 2, 3, 4, 5, 6, 8, 10	32	✓	0.50	0.93	0.624	0.250	-	0.38
1-1/16"	•	•	•	1/2, 1, 1-1/2, 2, 2-1/2, 3, 4, 5, 6, 8, 10, 12	32	✓	0.50	1.12	0.624	0.312	0.25	0.38
1-1/4"	•	•		1, 2, 3, 4, 5, 6, 7, 8, 10, 12	32	✓	0.75	1.34	0.749	0.437	0.38	0.50
1-1/2"	•	•	•	-	32	✓	0.75	1.56	0.749	0.437	0.38	0.62
1-3/4"	•	•		1, 2, 3, 4, 5, 6, 8, 10, 12	32		0.88	1.84	1.031	0.500	7/16	0.62
2"	•	•	•	-	32		0.88	2.08	1.374	0.625	0.50	0.75
2-1/2"	•	•		-	32		0.88	2.62	1.500	0.625	1/2	0.75
3"	•			-	32		1.25	3.16	1.630	0.750	5/8	0.88

Bore Size	SR								SRM			SR		SRM	
	EE	KK	KM	L	LB	PP	V	W	XJ	XJ	Y	Z	ZJ	ZJ	
5/16"	#10-32	#5-40 UNC	3/8-24	0.19	-	0.34	-	0.31	2.03	-	-	0.125	2.19	-	
7/16"	#10-32	#10-32 UNF	7/16-20	0.25	1.94	0.44	0.05	0.38	2.56	-	0.72	0.157	2.81	-	
9/16"	#10-32	#10-32 UNF	7/16-20	0.25	-	0.38	0.06	0.38	2.56	2.81	0.78	0.157	2.75	3.00	
3/4"	1/8 NPTF	1/4-28 UNF	5/8-18	0.34	2.91	0.62	0.09	0.50	3.75	3.75	0.97	0.251	4.03	4.03	
7/8"	1/8 NPTF	1/4-28 UNF	5/8-18	0.34	-	0.62	0.09	0.50	3.56	-	0.97	0.251	3.84	-	
1-1/16"	1/8 NPTF	5/16-24 UNF	5/8-18	0.34	-	0.62	0.09	0.62	3.84	4.01	1.19	0.251	4.12	4.28	
1-1/4"	1/8 NPTF	7/16-20 UNF	3/4-16	0.41	-	0.78	0.09	0.88	4.72	4.75	1.62	0.251	5.12	5.16	
1-1/2"	1/8 NPTF	7/16-20 UNF	3/4-16	0.50	-	0.77	0.09	0.88	4.38	4.63	1.50	0.376	4.75	5.00	
1-3/4"	1/4 NPTF	1/2-20 UNF	1-14	0.50	4.19 SR 4.44 SRM	1.12	0.09	1.06	5.75	6.00	1.94	0.376	6.25	6.50	
2"	1/4 NPTF	1/2-20 UNF	1-1/4-12	0.56	-	1.03	0.12	1.19	5.62	5.91	1.88	0.376	6.06	6.34	
2-1/2"	1/4 NPTF	1/2-20 UNF	1-3/8-12	0.56	-	1.03	0.13	1.19	5.62	5.62	1.84	0.376	6.06	6.06	
3"	3/8 NPTF	5/8-18 UNF	1-1/2-12	0.81	-	1.34	0.19	1.38	6.50	-	2.09	0.500	7.12	-	



For inventory, lead times, and kit lookup, visit [www.pdnplu.com](http://www.pdnplu.com)



Round Body  
Pneumatic Cylinders

SR/SRM/SRD/SRDM  
Series

SRG/SRGM  
Series

SRX  
Series

P1A  
Series

P  
Series



**Style DX**

Threaded both ends, double acting

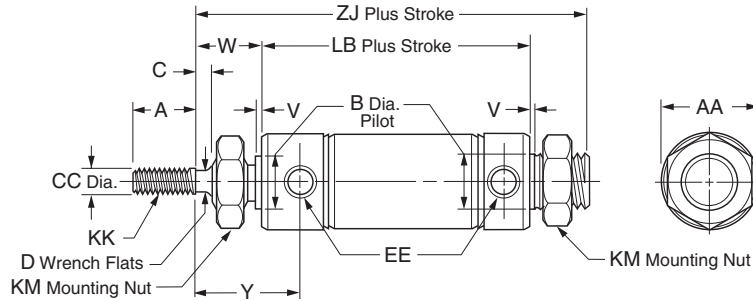

- C**
- Round Body  
Pneumatic Cylinders
- SR/SRM/SRD/SRDM  
Series
- SRG/SRGM  
Series
- SRX  
Series
- P1A  
Series
- P  
Series

Bore Size	SR	SRM	Std. Stroke (in)	Max. Stroke (in)	SS Rod Std
1-1/2"	•	•	1, 2, 3, 4, 5, 6, 8, 10, 12	32	✓

Bore Size	SR		SRM		SR		SRM									
	A	AA	B	C	CC	D	EE	KK	KM	LB	LB	V	W	Y	ZJ	ZJ
1-1/2"	0.75	1.56	0.749	0.25	0.437	0.38	1/8 NPTF	7/16-20 UNF	3/4-16	3.00	-	0.09	0.88	1.50	4.50	-



For inventory, lead times, and kit lookup, visit [www.pdnplu.com](http://www.pdnplu.com)

Mounting Style – KDX

Style KDX

Threaded both ends, double acting, double rod

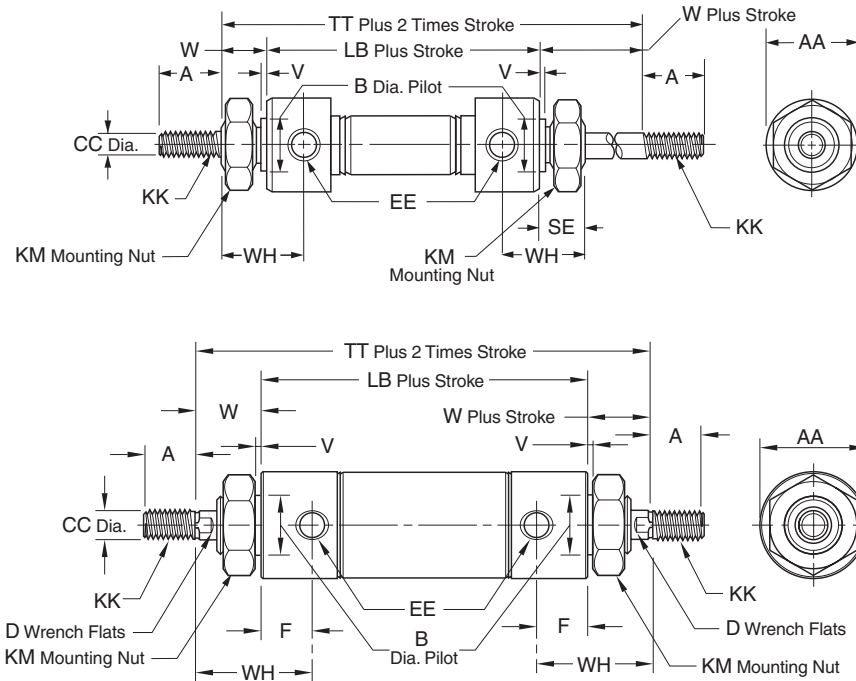

Bore Sizes

- 7/16"
- 3/4"

Bore Sizes

- 9/16" \*
- 7/8"
- 1-1/16"
- 1-1/4"
- 1-1/2"
- 1-3/4"
- 2" \*
- 2-1/2" \*
- 3" \*

\* No mounting nuts

Bore Size	SR	SRM	SRD SRDM	Std. Stroke (in)	Max. Stroke (in)	SS Rod	A	AA	B	CC
7/16"	•			1/2, 1, 1-1/2, 2, 3, 4	6	✓	0.50	0.74	0.437	0.188
9/16"	•	•	•	1/2, 1, 1-1/2, 2, 3, 4	6	✓	0.50	0.62	0.437	0.188
3/4"	•	•	•	1, 2, 3, 4, 5, 6	12	✓	0.50	0.86	0.624	0.250
7/8"	•			1, 2, 3, 4, 6	12	✓	0.50	0.93	0.624	0.250
1-1/16"	•	•	•	1, 2, 3, 4, 5, 6	12	✓	0.50	1.12	0.624	0.312
1-1/4"	•	•	•	1, 2, 3, 4, 5, 6	12	✓	0.75	1.34	0.749	0.437
1-1/2"	•	•	•	1, 2, 3, 4, 5, 6	12	✓	0.75	1.56	0.749	0.437
1-3/4"	•	•		1, 2, 3, 4, 5, 6	12	✓	0.88	1.84	1.031	0.500
2"	•	•	•	-	12	✓	0.88	2.08	1.374	0.625
2-1/2"	•	•		-	18	✓	0.88	2.62	1.500	0.625
3"	•			-	12	✓	1.25	3.16	1.630	0.750

Bore Size	D	EE	F	KK	KM	SR	SRM	SE	SR	SRM	V	W	WH
						LB	LB		TT	TT			
7/16"	-	#10-32	0.34	#10-32 UNF	7/16-20	2.06	-	0.38	2.81	-	0.05	0.38	0.72
9/16"	-	#10-32	0.40	#10-32 UNF	7/16-20	2.19	2.44	0.38	2.94	3.19	0.06	0.38	0.78
3/4"	-	1/8 NPTF	0.47	1/4-28 UNF	5/8-18	3.00	3.00	0.50	4.00	4.00	0.09	0.50	0.97
7/8"	-	1/8 NPTF	0.47	1/4-28 UNF	5/8-18	2.91	-	0.50	3.91	-	0.09	0.50	0.97
1-1/16"	0.25	1/8 NPTF	0.56	5/16-24 UNF	5/8-18	2.75	3.28	0.50	4.00	4.53	0.09	0.62	1.19
1-1/4"	0.38	1/8 NPTF	0.75	7/16-20 UNF	3/4-16	3.81	3.84	0.63	5.56	5.59	0.09	0.88	1.62
1-1/2"	0.38	1/8 NPTF	0.62	7/16-20 UNF	3/4-16	3.38	3.63	0.63	5.12	5.38	0.09	0.88	1.50
1-3/4"	7/16	1/4 NPTF	0.88	1/2-20 UNF	1-14	4.44	4.69	0.75	6.56	6.81	0.09	1.06	1.94
2"	0.50	1/4 NPTF	0.65	1/2-20 UNF	1-1/4-12	4.19	4.47	-	6.56	6.84	0.12	1.19	1.88
2-1/2"	1/2	1/4 NPTF	0.65	1/2-20 UNF	1-3/8-12	4.19	4.19	-	6.56	6.56	0.13	1.19	1.84
3"	5/8	3/8 NPTF	0.71	5/8-18 UNF	1-1/2-12	4.56	-	-	7.31	-	0.19	1.38	2.09



Round Body  
Pneumatic Cylinders

SR/SRM/SRD/SRDM  
Series

SRG/SRGM  
Series

SRX  
Series

P1A  
Series

P  
Series



For inventory, lead times, and kit lookup, visit [www.pdnplu.com](http://www.pdnplu.com)

Mounting Style – KDXH, A

Style KDXH

Threaded both ends, double rod, hollow rod

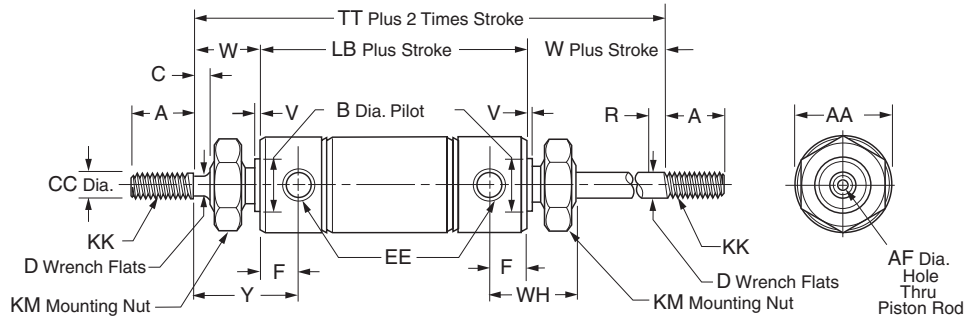

Bore Size	SR	SRM	Std. Stroke (in)	Max. Stroke (in)	SS Rod	A	AA	AF	B	C	CC
1-1/16"	•	•	1, 2, 3, 4, 5, 6	12	N/A	0.50	1.12	0.187	0.624	0.12	0.312
1-1/4"	•	•	1, 2, 3, 4, 5, 6	12	N/A	0.75	1.34	0.250	0.749	0.25	0.437
1-1/2"	•	•	1, 2, 3, 4, 5, 6	12	N/A	0.75	1.56	0.250	0.749	0.25	0.437
1-3/4"	•	•	1, 2, 3, 4, 5, 6	12	N/A	0.88	1.84	0.328	1.031	0.38	0.500

Bore Size	D	EE	F	KK	KM	LB		R	TT		V	W	WH	Y
						SR	SRM		SR	SRM				
1-1/16"	0.25	1/8 NPTF	0.56	5/16-24 UNF	5/8-18	2.75	3.28	0.12	4.00	4.53	0.09	0.62	1.06	1.19
1-1/4"	0.38	1/8 NPTF	0.75	7/16-20 UNF	3/4-16	3.81	3.84	0.25	5.56	5.59	0.09	0.88	1.38	1.62
1-1/2"	0.38	1/8 NPTF	0.62	7/16-20 UNF	3/4-16	3.38	3.63	0.25	5.12	5.38	0.09	0.88	1.25	1.50
1-3/4"	7/16	1/4 NPTF	0.88	1/2-20 UNF	1-14	4.44	4.69	-	6.56	6.81	0.09	1.06	1.63	1.63

Style A

Nose mount, spring return, head adjustable stroke

No partial stroke lengths. Only available in full inch strokes.

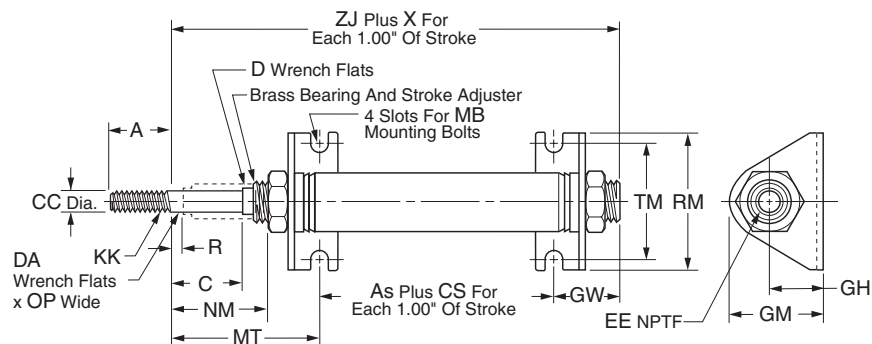

Bore Size	SR	SRM	Std. Stroke	Max. Stroke (in)	SS Rod Std	A	AS	C	CC	CS	D
3/4"	•	•	Stroke adjustment in 1" increments to 3": 1" stroke adjusts 0-1" 2" stroke adjusts 1-2" 3" stroke adjusts 2-3"	6	✓	0.50	-0.03	1.19	0.250	1.69	-
1-1/16"	•	•		6	✓	0.50	0.32	1.25	0.312	1.56	0.25
1-1/2"	•	•		6	✓	0.75	0.19	1.25	0.437	2.00	0.62

Bore Size	EE	GH	GM	GW	KK	MB	MT	NM	OP	R	RM	TM	X	ZJ
3/4"	1/8 NPTF	0.81	1.38	0.94	1/4-28 UNF	0.250	2.21	1.40	-	0.32	1.88	1.50	1.69	3.14
1-1/16"	1/8 NPTF	0.81	1.38	0.93	5/16-24 UNF	0.250	2.38	1.44	0.12	0.25	1.88	1.50	1.56	3.63
1-1/2"	1/8 NPTF	1.00	1.78	1.25	7/16-20 UNF	0.250	2.56	1.50	-	0.25	2.50	1.88	2.00	4.00



For inventory, lead times, and kit lookup, visit [www.pdnplu.com](http://www.pdnplu.com)

**Style RA**

**Nose mount, spring extend, cap adjustable stroke**

No partial stroke lengths. Only available in full inch strokes.

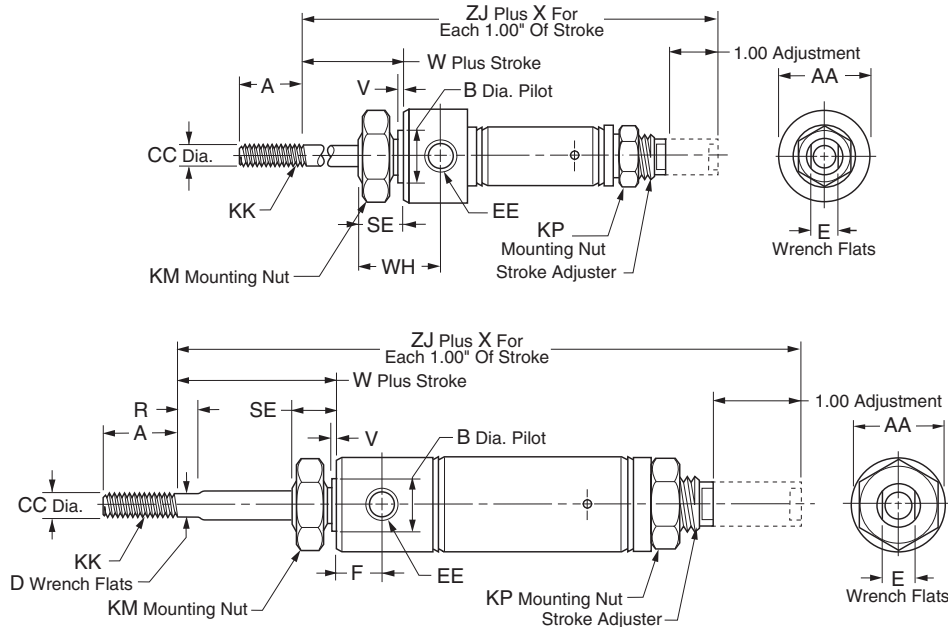

Bore Sizes

3/4"

Bore Sizes

1-1/16"

1-1/2"

Bore Size	SR	SRM	Std. Stroke	Max. Stroke (in)	SS Rod Std
3/4"	•		Stroke adjustment in 1" increments to 3":	6	✓
1-1/16"	•		1" stroke adjusts 0-1" 2" stroke adjusts 1-2"	6	✓
1-1/2"	•		3" stroke adjusts 2-3"	6	✓

Bore Size	A	AS	AA	B	CC	D	E	EE	F
3/4"	0.50	1.69	0.86	0.624	0.250	-	0.34	1/8 NPTF	-
1-1/16"	0.50	0.32	1.12	0.624	0.312	0.25	0.50	1/8 NPTF	0.56
1-1/2"	1.25	0.19	1.56	0.749	0.437	0.38	0.62	1/8 NPTF	0.62

Bore Size	KK	KM	SE	R	V	W	WH	X	ZJ
3/4"	1/4-28 UNF	5/8-18	0.50	-	0.09	0.53	0.97	2.69	3.61
1-1/16"	5/16-24 UNF	5/8-18	0.50	0.12	0.09	0.50	-	2.56	4.03
1-1/2"	7/16-20 UNF	3/4-16	0.62	0.25	0.09	0.88	-	3.00	4.81



Round Body  
Pneumatic Cylinders

SR/SRM/SRD/SRDM  
Series

SRG/SRGM  
Series

SRX  
Series

P1A  
Series

P  
Series



For inventory, lead times, and kit lookup, visit [www.pdnplu.com](http://www.pdnplu.com)

Mounting Style – AP

Style AP

Pivot mount, spring return, head adjustable stroke

No partial stroke lengths. Only available in full inch strokes.

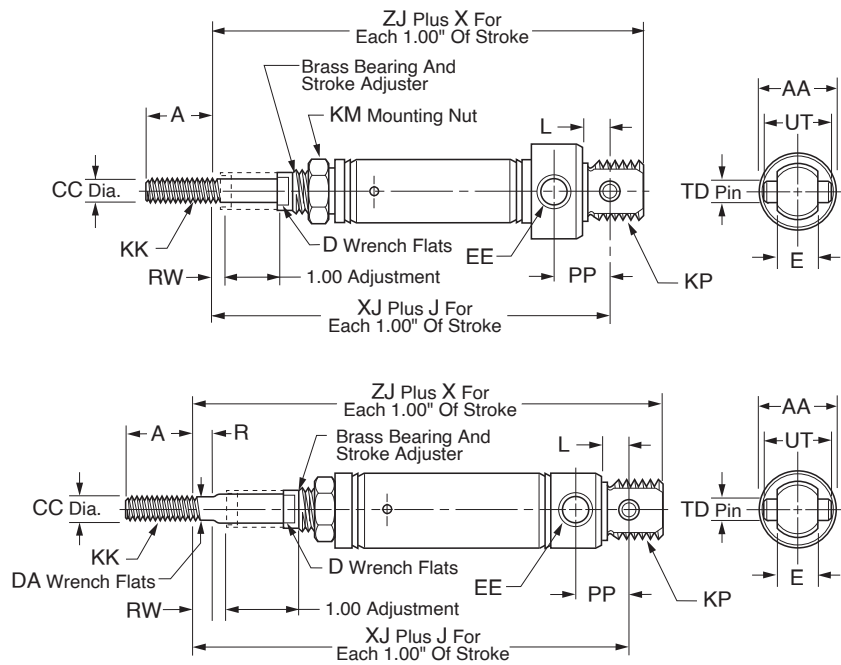

Bore Sizes

3/4"

Bore Sizes

1-1/16"

1-1/2"

C  
Round Body  
Pneumatic Cylinders  
SR/SRM/SRD/SRDM  
Series  
SRG/SRGM  
Series  
SRX  
Series  
P1A  
Series  
P  
Series

Bore Size	SR	SRM	Std. Stroke	Max. Stroke (in)	SS Rod Std
3/4"	•		Stroke adjustment in 1" increments to 3":	6	✓
1-1/16"	•		1" stroke adjusts 0-1" 2" stroke adjusts 1-2"	6	✓
1-1/2"	•		3" stroke adjusts 2-3"	6	✓

Bore Size	A	AA	CC	D	DA	E	EE	J	KK
3/4"	0.50	0.86	0.250	0.34	–	0.38	1/8 NPTF	1.69	1/4-28 UNF
1-1/16"	0.50	1.12	0.312	0.50	0.25	0.38	1/8 NPTF	1.56	5/16-24 UNF
1-1/2"	0.75	1.56	0.437	0.62	0.38	0.62	1/8 NPTF	2.00	7/16-20 UNF

Bore Size	KM	KP	L	OP	PP	R	RW	TD	UT	X	XJ	ZJ
3/4"	7/16-20	5/8-18 UNF	0.34	–	0.62	0.32	0.19	0.250	0.75	1.69	3.60	3.88
1-1/16"	–	5/8-18 UNF	0.34	0.25	0.62	0.12	0.25	0.250	0.75	1.56	3.89	4.16
1-1/2"	3/4-16	–	0.50	–	0.77	0.25	0.25	0.375	1.00	2.00	4.31	4.69



For inventory, lead times, and kit lookup, visit [www.pdnplu.com](http://www.pdnplu.com)

C20

Parker Hannifin Corporation  
Pneumatic Division  
Wadsworth, Ohio  
[www.parker.com/pneumatics](http://www.parker.com/pneumatics)

**Style BRN**

Rear block mount, single acting, spring return

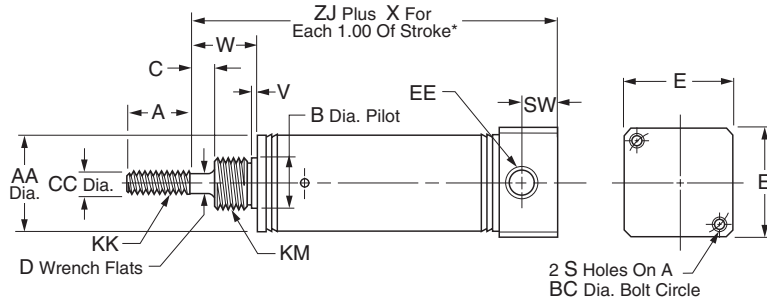

Bore Size	SR	SRM	Std. Stroke (in)	Max. Stroke (in)	SS Rod Std	A	AA	B	C	CC	D
7/16"	•		1/2, 1, 2, 3, 4	6	✓	0.50	0.5	0.374	–	0.188	–
3/4"	•	•	1, 2, 3, 4	6	✓	0.75	0.81	0.499	0.25	0.250	0.22
1-1/16"	•	•	1, 2, 3, 4	6	✓	0.75	1.12	0.624	0.38	0.312	0.25
1-1/2"	•	•	1, 2, 3, 4	6	✓	1.25	1.56	0.749	0.25	0.437	0.38

Bore Size	E	EE	KK	KM	SW	V	W	X	SR ZJ	SRM ZJ
7/16"	0.75	#10-32	#10-32 UNF	3/8-24	0.38	0.05	0.31	0.94	1.62	–
3/4"	1.00	1/8 NPTF	1/4-28 UNF	1/2-20	0.44	0.09	0.62	1.69	2.31	2.56
1-1/16"	1.25	1/8 NPTF	5/16-24 UNF	5/8-18	0.44	0.09	0.88	1.81	2.81	3.06
1-1/2"	1.75	1/4 NPTF	7/16-20 UNF	3/4-16	0.62	0.09	0.88	2.00	3.06	3.31

\* To determine lengths for half inch stroke increments, determine length for next highest whole number stroke and subtract one half inch.

**Style BRR**

Rear block mount, single acting, spring extend

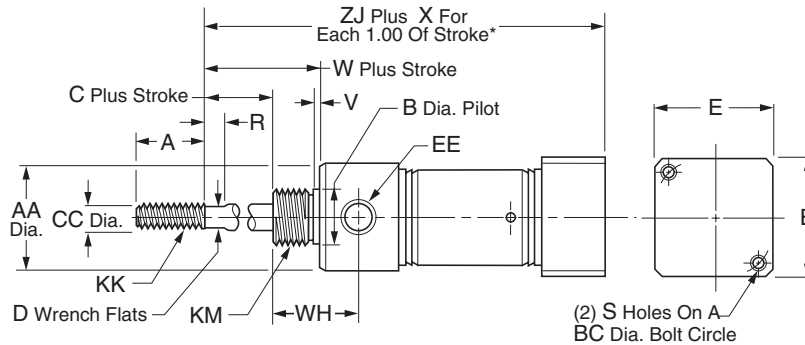

Bore Size	SR	SRM	Std. Stroke (in)	Max. Stroke (in)	SS Rod Std	A	AA	B	BC	C	CC	D
3/4"	•	•	1, 2, 3, 4	6	✓	0.75	0.86	0.624	1.00	0.25	0.250	0.22
1-1/16"	•	•	1, 2, 3, 4	6	✓	0.75	1.12	0.624	1.25	0.38	0.312	0.25
1-1/2"	•	•	1, 2, 3, 4	6	✓	1.25	1.56	0.749	1.75	0.25	0.437	0.38

Bore Size	E	EE	KK	KM	R	S	V	W	WH	X	ZJ SR	SRM
3/4"	1.00	1/8 NPTF	1/4-28 UNF	5/8-18	0.25	#10-32 UNF	0.09	0.75	0.97	2.69	3.22	3.47
1-1/16"	1.25	1/8 NPTF	5/16-24 UNF	5/8-18	0.25	#10-32 UNF	0.09	0.88	1.06	2.81	3.53	3.78
1-1/2"	1.75	1/4 NPTF	7/16-20 UNF	3/4-16	0.25	1/4-20 UNC	0.09	0.88	1.25	3.00	3.88	4.13

\* To determine lengths for half inch stroke increments, determine length for next highest whole number stroke and subtract one half inch.

**C**  
 Round Body  
 Pneumatic Cylinders  
 SR/SRM/SRD/SRDM  
 Series  
 SRG/SRGM  
 Series  
 SRX  
 Series  
 P1A  
 Series  
 P  
 Series



For inventory, lead times, and kit lookup, visit [www.pdnplu.com](http://www.pdnplu.com)

Mounting Style – BFD

Style BFD

Front block mount, double acting

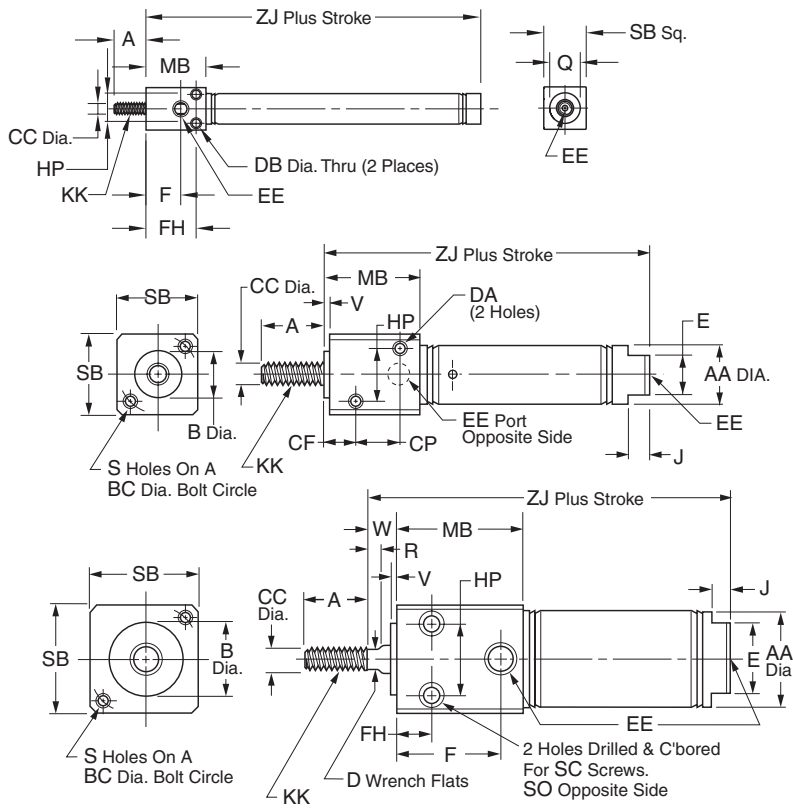

Bore Sizes
5/16"

Bore Sizes
7/16"

Bore Sizes
3/4"
1-1/16"
1-1/2"

Bore Size	Std. Stroke (in)		Max. Stroke (in)	SS Rod Std	A	AA	B	BC	CC
	SR	SRM							
5/16"	•	1/2, 1, 1-1/2, 2, 2-1/2, 3, 4	4	✓	0.38	-	-	-	0.125
7/16"	•	1/2, 1, 1-1/2, 2, 3, 4	12	✓	0.50	0.50	0.437	0.75	0.188
3/4"	•	1/2, 1, 2, 3, 4, 5, 6	12	✓	0.75	0.81	0.624	1.00	0.250
1-1/16"	•	1, 2, 3, 4, 5, 6	12	✓	0.75	1.12	0.750	1.25	0.312
1-1/2"	•	1, 2, 3, 4, 5, 6	12	✓	1.25	1.56	1.00	1.75	0.437

Bore Size	CF	CP	D	DA	DB	E	EE	F	FH	HP	J
	5/16"	-	-	-	-	0.11	-	#10-32	0.41	0.59	0.34
7/16"	0.31	0.44	-	#8-32	-	0.38	#10-32	-	0.31	0.44	0.19
3/4"	-	-	0.22	-	-	0.62	1/8 NPTF	0.88	0.38	0.62	0.19
1-1/16"	-	-	0.25	-	-	0.88	1/8 NPTF	1.16	0.62	0.81	0.19
1-1/2"	-	-	0.38	-	-	0.88	1/4 NPTF	1.53	0.88	1.12	0.25

Bore Size											SR	SRM
	KK	MB	Q	R	S	SB	SC	SO	V	W	ZJ	ZJ
5/16"	#5-40 UNC	0.71	0.36	-	-	0.50 SQ	-	-	-	-	1.75	-
7/16"	#10-32 UNF	0.88	-	-	#8-32 UNC	0.75	-	-	0.062	-	2.12	-
3/4"	1/4-28 UNF	1.12	-	-	#10-32 UNF	1.00	#10-32	1/4-20 UNC	0.093	0.34	3.22	3.22
1-1/16"	5/16-24 UNF	1.41	-	0.25	#10-32 UNF	1.25	#10-32	1/4-20 UNC	0.093	0.47	3.75	3.91
1-1/2"	7/16-20 UNF	1.88	-	-	1/4-20 UNC	1.75	1/4-20	5/16-18 UNC	0.125	0.38	4.19	4.44



For inventory, lead times, and kit lookup, visit [www.pdnplu.com](http://www.pdnplu.com)

C  
 Round Body Pneumatic Cylinders  
 SR/SRM/SRD/SRDM Series  
 SRG/SRGM Series  
 SRX Series  
 P1A Series  
 P Series



**Style BRD**

Rear block mount, double acting

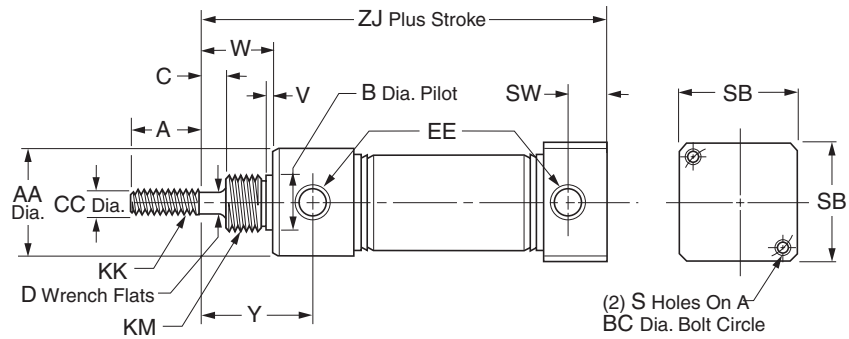

Bore Size	SR	SRM	Std. Stroke (in)	Max. Stroke (in)	SS Rod Std
7/16"	•		1/2, 1, 2, 3, 4	12	✓
3/4"	•	•	1, 2, 3, 4, 5, 6	12	✓
1-1/16"	•	•	1, 2, 3, 4	12	✓
1-1/2"	•	•	1, 2, 3, 4, 5, 6	12	✓

Bore Size	A	AA	B	BC	C	CC	D	EE	KK
7/16"	0.50	0.74	0.437	0.75	–	0.188	–	#10-32	#10-32 UNF
3/4"	0.75	0.86	0.624	1.00	0.25	0.250	0.22	1/8 NPTF	1/4-28 UNF
1-1/16"	0.75	1.12	0.624	1.25	0.38	0.312	0.25	1/8 NPTF	5/16-24 UNF
1-1/2"	1.25	1.56	0.749	1.75	0.25	0.437	0.38	1/4 NPTF	7/16-20 UNF

Bore Size	KM	S	SB	SW	V	W	Y	SR		SRM	
								ZJ	ZJ	ZJ	ZJ
7/16"	7/16-20 UNF	#8-32 UNC	0.75	0.38	0.05	0.43	0.72	2.44	–		
3/4"	5/8-18 UNF	#10-32 UNF	1.00	0.44	0.09	0.75	1.22	3.78	3.78		
1-1/16"	5/8-18 UNF	#10-32 UNF	1.25	0.44	0.09	0.88	1.44	4.00	4.16		
1-1/2"	3/4-16 UNF	1/4-20 UNC	1.75	0.62	0.09	0.88	1.47	4.38	4.63		

**C**

Round Body  
Pneumatic Cylinders

---

SR/SRM/SRD/SRDM  
Series

---

SRG/SRGM  
Series

---

SRX  
Series

---

P1A  
Series

---

P  
Series



For inventory, lead times, and kit lookup, visit [www.pdnplu.com](http://www.pdnplu.com)

**Style BFN**

Front block mount, single acting, spring return

**Bore Sizes**

7/16"

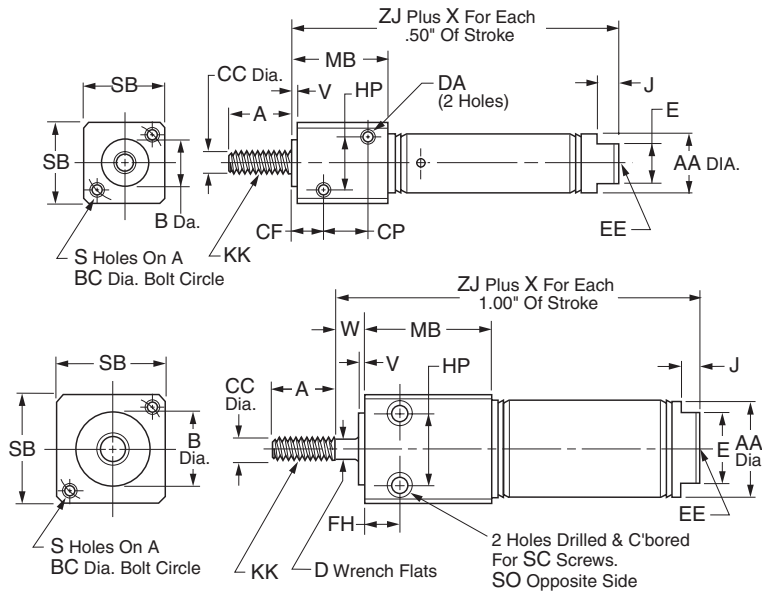

**Bore Sizes**

3/4"

1-1/16"

1-1/2"

Bore Size	SR	SRM	Std. Stroke (in)	Max Stroke (in)	SS Rod Std
7/16"	•		1/2, 1, 1-1/2, 2, 3	6	✓
3/4"	•	•	1/2, 1, 2, 3, 4	6	✓
1-1/16"	•	•	1, 2, 3, 4	6	✓
1-1/2"	•	•	1, 2, 3, 4	6	✓

Bore Size	A	AA	B	BC	CC	CF	CP	D	DA	E	EE	FH
7/16"	0.50	0.50	0.437	0.75	0.188	0.31	0.44	-	#8-32 UNC	0.38	#10-32	0.31
3/4"	0.75	0.81	0.624	1.00	0.250	-	-	0.22	-	0.62	1/8 NPTF	0.38
1-1/16"	0.75	1.12	0.750	1.25	0.312	-	-	0.25	-	0.88	1/8 NPTF	0.62
1-1/2"	1.25	1.56	1.00	1.75	0.437	-	-	0.38	-	0.88	1/4 NPTF	0.88

Bore Size													SR	SRM
	HP	J	KK	MB	S	SB	SC	SO	V	W	X	ZJ	ZJ	
7/16"	0.44	0.19	#10-32 UNF	0.88	#8-32 UNC	0.75	-	-	0.062	-	0.94	1.94	-	
3/4"	0.62	0.19	1/4-28 UNF	1.12	#10-32 UNF	1.00	#10-32	1/4-20 UNC	0.093	0.34	1.69	2.66	2.91	
1-1/16"	0.81	0.19	5/16-24 UNF	1.41	#10-32 UNF	1.25	#10-32	1/4-20 UNC	0.093	0.47	1.81	3.38	3.63	
1-1/2"	1.12	0.25	7/16-20 UNF	1.88	1/4 UNC	1.75	1/4-20	5/16-18 UNC	0.125	0.38	2.00	3.69	3.94	

\* To determine lengths for half inch stroke increments, determine length for next highest whole number stroke and subtract one half inch.

**C**  
 Round Body Pneumatic Cylinders  
 SR/SRM/SRD/SRDM Series  
 SRG/SRGM Series  
 SRX Series  
 P1A Series  
 P Series



For inventory, lead times, and kit lookup, visit [www.pdnplu.com](http://www.pdnplu.com)

**Style BFR**

Front block mount, single acting, spring extend

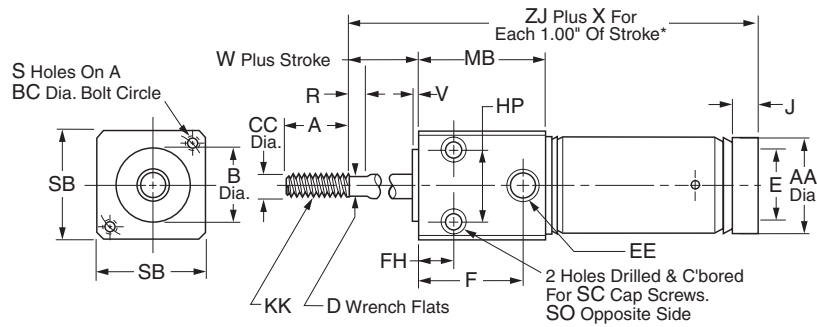

Bore Size	SR	SRM	Std. Stroke (in)	Max Stroke (in)	SS Rod Std
3/4"	•	•	1, 2, 3, 4	6	✓
1-1/16"	•	•	1, 2, 3, 4	6	✓
1-1/2"	•	•	1, 2, 3, 4	6	✓

Bore Size	A	AA	B	BC	CC	D	E	EE	F	FH	HP	J
3/4"	0.75	0.81	0.624	1.00	0.250	0.22	-	1/8 NPTF	0.88	0.38	0.62	0.19
1-1/16"	0.75	1.12	0.750	1.25	0.312	0.25	-	1/8 NPTF	1.16	0.62	0.81	-
1-1/2"	1.25	1.56	1.00	1.75	0.437	0.38	0.88	1/4 NPTF	1.53	0.88	1.12	0.25

Bore Size	KK	MB	R	S	SB	SC	SO	V	W	X	SR		SRM	
											ZJ	ZJ	ZJ	ZJ
3/4"	1/4-28 UNF	1.12	0.25	#10-32 UNF	1.00	#10-32	1/4-20 UNC	0.093	0.34	2.69	2.56	2.81		
1-1/16"	5/16-24 UNF	1.41	0.25	#10-32 UNF	1.25	#10-32	1/4-20 UNC	0.093	0.47	2.81	3.12	3.37		
1-1/2"	7/16-20 UNF	1.88	0.25	1/4-20 UNC	1.75	1/4-20	5/16-18 UNC	0.125	0.38	3.00	3.69	3.94		

\* To determine lengths for half inch stroke increments, determine length for next highest whole number stroke and subtract one half inch.

C

Round Body  
Pneumatic Cylinders

SR/SRM/SRD/SRDM  
Series

SRG/SRGM  
Series

SRX  
Series

P1A  
Series

P  
Series



For inventory, lead times, and kit lookup, visit [www.pdnplu.com](http://www.pdnplu.com)

Style TRN

Rear trunnion mount, single acting, spring return

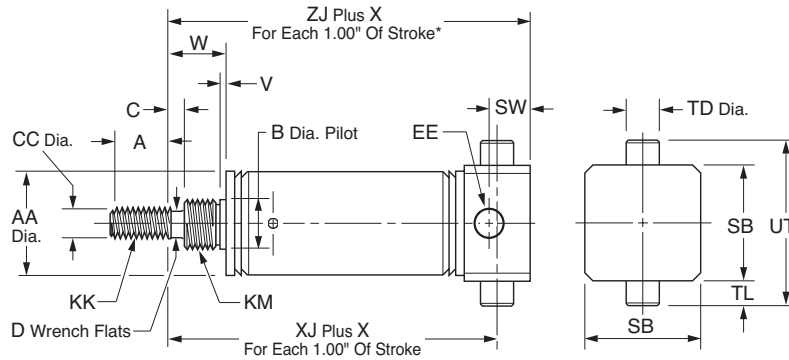

Bore Size	SR	SRM	Std. Stroke (in)	Max. Stroke (in)	SS Rod Std	A	AA	B	C	CC	D	EE
7/16"	•		1/2, 1, 2, 3, 4	6	✓	0.50	0.50	0.374	–	0.188	–	#10-32
3/4"	•	•	1, 2, 3, 4	6	✓	0.75	0.81	0.499	0.25	0.250	0.22	1/8 NPTF
1-1/16"	•	•	1, 2, 3, 4	6	✓	0.75	1.12	0.624	0.38	0.312	0.25	1/8 NPTF
1-1/2"	•	•	1, 2, 3, 4	6	✓	1.25	1.56	0.749	0.25	0.437	0.38	1/4 NPTF

Bore Size	KK	KM	SB	SW	TD	TL	UT	V	W	X	SR XJ	SRM XJ	SR ZJ	SRM ZJ
7/16"	#10-32 UNF	3/8-24 UNF	0.75	0.38	0.374	0.50	1.25	0.05	0.32	0.94**	1.38	–	1.62	–
3/4"	1/4-28 UNF	1/2-20 UNF	1.00	0.44	0.500	0.38	1.75	0.09	0.62	1.69	1.94	2.19	2.31	2.56
1-1/16"	5/16-24 UNF	5/8-18 UNF	1.25	0.44	0.500	0.38	2.00	0.09	0.88	1.81	2.44	2.69	2.81	3.06
1-1/2"	7/16-20 UNF	3/4-16 UNF	1.75	0.62	0.500	0.38	2.50	0.09	0.88	2.00	2.56	2.81	3.06	3.31

\* To determine lengths for half inch stroke increments, determine length for next highest whole number stroke and subtract one half inch.

\*\* For each 0.50" of stroke.

Style TRR

Rear trunnion mount, single acting, spring extend

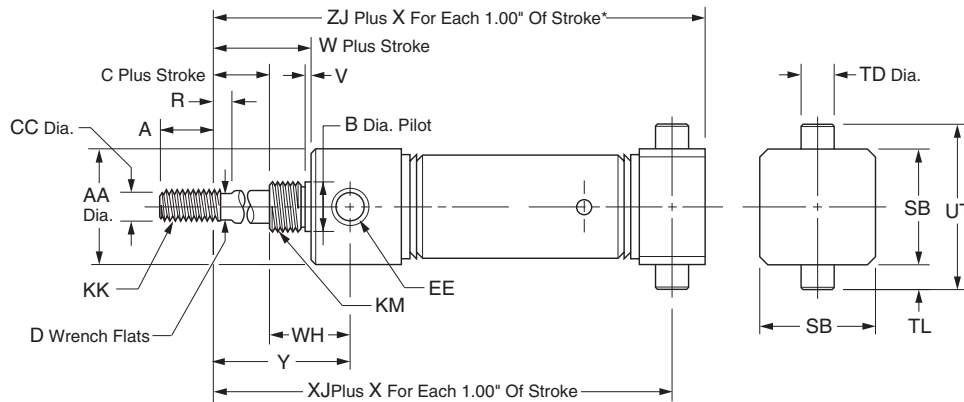

Bore Size	SR	SRM	Std. Stroke (in)	Max. Stroke (in)	SS Rod Std	A	AA	B	C	CC	D	EE
3/4"	•	•	1, 2, 3, 4	6	3	0.75	0.86	0.624	0.25	0.250	0.22	1/8 NPTF
1-1/16"	•	•	1, 2, 3, 4	6	3	0.75	1.12	0.624	0.38	0.312	0.25	1/8 NPTF
1-1/2"	•	•	1, 2, 3, 4	6	3	1.25	1.56	0.749	0.25	0.437	0.38	1/4 NPTF

Bore Size	KK	KM	R	SB	TD	TL	UT	V	W	WH	X	SR XJ	SRM XJ	SR ZJ	SRM ZJ
3/4"	1/4-28 UNF	1/2-20 UNF	0.25	1.00	0.500	0.38	1.75	0.09	0.75	0.72	2.69	2.85	3.10	3.22	3.47
1-1/16"	5/16-24 UNF	5/8-18 UNF	0.25	1.25	0.500	0.38	2.00	0.09	0.88	0.68	2.81	3.15	3.40	3.53	3.78
1-1/2"	7/16-20 UNF	3/4-16 UNF	0.25	1.75	0.500	0.38	2.50	0.09	0.88	1.25	3.00	3.38	3.63	3.88	4.13

\* To determine lengths for half inch stroke increments, determine length for next highest whole number stroke and subtract one half inch.

**C**  
 Round Body  
 Pneumatic Cylinders  

---

**SR/SRM/SRD/SRDM**  
 Series  

---

**SRG/SRGM**  
 Series  

---

**SRX**  
 Series  

---

**P1A**  
 Series  

---

**P**  
 Series



For inventory, lead times, and kit lookup, visit [www.pdnplu.com](http://www.pdnplu.com)

**Style TFD**

Front trunnion mount, double acting

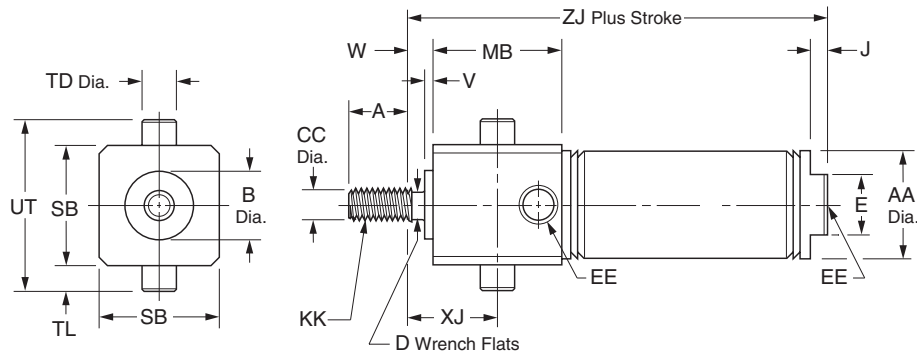

Bore Size	SR	SRM	Std. Stroke (in)	Max. Stroke (in)	SS Rod Std	A	AA	B	CC	D	E	EE
7/16"	•		1/2, 1, 1-1/2, 2, 3, 4	12	✓	0.50	0.50	0.437	0.188	–	0.38	#10-32
3/4"	•	•	1, 2, 3, 4, 5, 6	12	✓	0.75	0.81	0.624	0.250	0.22	0.62	1/8 NPTF
1-1/16"	•	•	1, 2, 3, 4, 5, 6	12	✓	0.75	1.12	0.750	0.312	0.25	0.88	1/8 NPTF
1-1/2"	•	•	1, 2, 3, 4, 5, 6	12	✓	1.25	1.56	1.000	0.437	0.38	0.88	1/4 NPTF

Bore Size	J	KK	MB	SB	TD	TL	UT	V	W	XJ	SR ZJ	SRM ZJ
7/16"	0.19	#10-32 UNF	0.88	0.75	0.374	0.250	1.25	0.062	–	0.31	2.12	–
3/4"	0.19	1/4-28 UNF	1.12	1.00	0.500	0.38	1.75	0.093	0.34	0.69	3.22	3.22
1-1/16"	0.19	5/16-24 UNF	1.41	1.25	0.500	0.38	2.00	0.093	0.47	1.09	3.75	3.91
1-1/2"	0.25	7/16-20 UNF	1.88	1.75	0.500	0.38	2.50	0.125	0.38	1.31	4.19	4.44

**Style TRD**

Rear trunnion mount, double acting

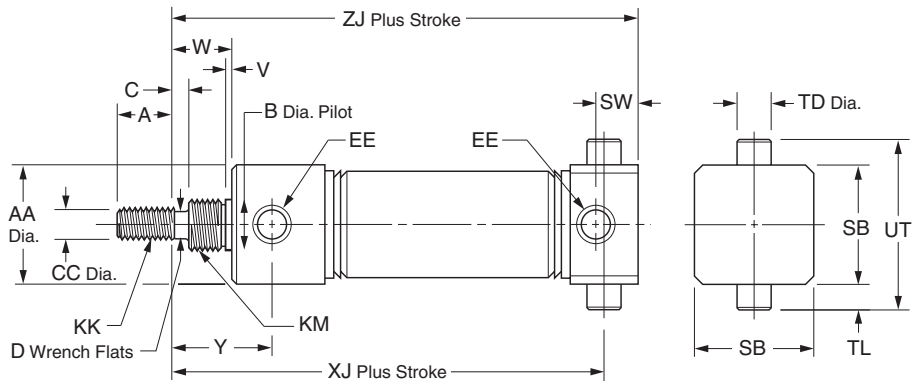

Bore Size	SR	SRM	Std. Stroke (in)	Max. Stroke (in)	SS Rod Std	A	AA	B	C	CC	D	EE
7/16"	•		1/2, 1, 1-1/2, 2, 3, 4	12	✓	0.50	0.74	0.437	–	0.188	–	#10-32
3/4"	•	•	1, 2, 3, 4, 5, 6	12	✓	0.75	0.86	0.624	0.25	0.250	0.22	1/8 NPTF
1-1/16"	•	•	1, 2, 3, 4	12	✓	0.75	1.12	0.624	0.38	0.312	0.25	1/8 NPTF
1-1/2"	•	•	1, 2, 3, 4, 5, 6	12	✓	1.25	1.56	0.749	0.25	0.437	0.38	1/4 NPTF

Bore Size	KK	KM	SB	SW	TD	TL	UT	V	W	SR XJ	SRM XJ	Y	SR ZJ	SRM ZJ
7/16"	1/4-28 UNF	5/8-18 UNF	0.75	0.38	0.374	0.25	1.25	0.05	0.38	2.19	–	0.72	2.44	–
3/4"	5/16-24 UNF	5/8-18 UNF	1.00	0.44	0.500	0.38	1.75	0.09	0.75	3.41	3.41	1.22	3.78	3.78
1-1/16"	7/16-20 UNF	3/4-16 UNF	1.25	0.44	0.500	0.38	2.00	0.09	0.88	3.62	3.62	1.44	4.00	4.16
1-1/2"			1.75	0.62	0.500	0.38	2.50	0.09	0.88	3.88	4.13	1.47	4.38	4.63



Round Body  
Pneumatic Cylinders

SR/SRM/SRD/SRDM  
Series

SRG/SRGM  
Series

SRX  
Series

P1A  
Series

P  
Series



For inventory, lead times, and kit lookup, visit [www.pdnplu.com](http://www.pdnplu.com)

Style TFN

Front trunnion mount, single acting, spring return

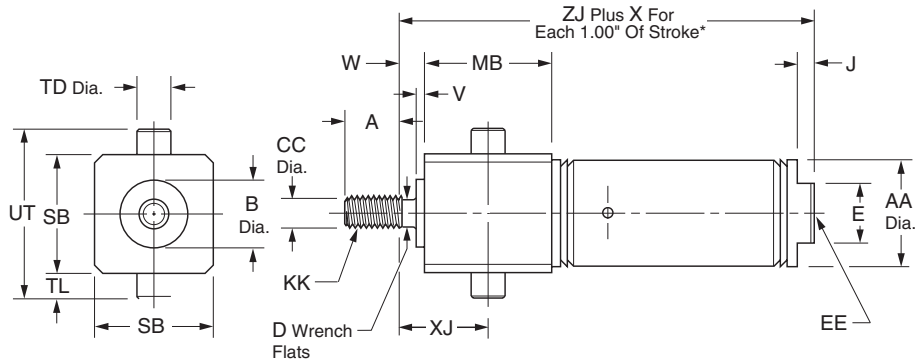

Bore Size	SR	SRM	Std. Stroke (in)	Max. Stroke (in)	SS Rod Std	A	AA	B	CC	D	E	EE
7/16"	•		1/2, 1, 1-1/2, 2, 3	6	✓	0.50	0.50	0.437	0.188	–	0.38	#10-32
3/4"	•	•	1/2, 1, 2, 3, 4	6	✓	0.75	0.81	0.624	0.250	0.22	0.62	1/8 NPTF
1-1/16"	•	•	1, 2, 3, 4	6	✓	0.75	1.12	0.750	0.312	0.25	0.88	1/8 NPTF
1-1/2"	•	•	1, 2, 3, 4	6	✓	1.25	1.56	1.000	0.437	0.38	0.88	1/4 NPTF

Bore Size	J	KK	MB	SB	TD	TL	UT	V	W	X	XJ	SR ZJ	SRM ZJ
7/16"	0.19	#10-32 UNF	0.88	0.75	0.374	0.25	1.25	0.062	0	0.94**	0.31	1.94	–
3/4"	0.19	5/16-24 UNF	1.12	1.00	0.500	0.38	1.75	0.093	0.34	1.69	0.69	2.66	2.91
1-1/16"	0.25	7/16-20 UNF	1.41	1.25	0.500	0.38	2.00	0.093	0.47	1.81	1.09	3.38	3.63
1-1/2"			1.88	1.75	0.500	0.38	2.50	0.125	0.38	2.00	1.31	3.69	3.94

\* To determine lengths for half inch stroke increments, determine length for next highest whole number stroke and subtract one half inch.

\*\* For each 0.50" of stroke

Mounting Style TFR

Front trunnion mount, single acting, spring extend

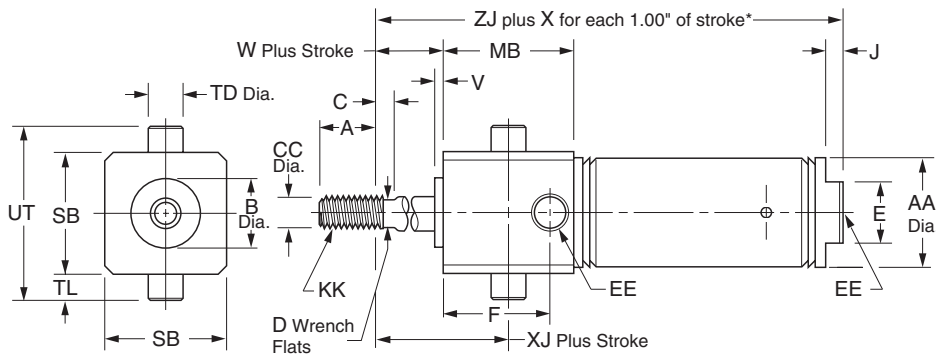

Bore Size	SR	SRM	Std. Stroke (in)	Max. Stroke (in)	Ss Rod Std	A	AA	B	C	CC	D	E
3/4"	•	•	1, 2, 3, 4	6	✓	0.75	0.81	0.624	0.25	0.250	0.22	0
1-1/16"	•	•	1, 2, 3, 4	6	✓	0.75	1.12	0.750	0.25	0.312	0.25	0
1-1/2"	•	•	1, 2, 3, 4	6	✓	1.25	1.56	1.000	0.25	0.437	0.38	0.88

Bore Size	F	EE	J	KK	MB	SB	TD	TL	UT	V	W	X	XJ	SR ZJ	SRM ZJ
3/4"	0.88	1/8 NPTF	–	1/4-28 UNF	1.12	1.00	0.500	0.38	1.75	0.093	0.34	2.69	0.69	2.56	2.81
1-1/16"	1.16	1/8 NPTF	–	5/16-24 UNF	1.41	1.25	0.500	0.38	2.00	0.093	0.47	2.81	1.09	3.12	3.37
1-1/2"	–	1/4 NPTF	0.25	7/16-20 UNF	1.88	1.75	0.500	0.38	2.50	0.125	0.38	3.00	1.31	3.69	3.94

\* To determine lengths for half inch stroke increments, determine length for next highest whole number stroke and subtract one half inch.



For inventory, lead times, and kit lookup, visit [www.pdnplu.com](http://www.pdnplu.com)

**Air Reservoirs**

Air Reservoirs installed can significantly reduce the pulsation of a system. In addition air reservoirs can be used as a means to store energy. Caution should always be used when storing energy. Air reservoirs if installed in the correct location and sized correctly can temporarily increase the flow of an actuator or cylinder.

As always never exceed the rated pressure of the cylinder.

**Ordering information**

<div style="border: 1px solid black; padding: 5px; width: fit-content; margin: 0 auto;">.75</div> <div style="border: 1px solid black; padding: 5px; width: fit-content; margin: 5px auto;"> <b>Bore Size*</b>  <table border="1" style="width: 100%; border-collapse: collapse;"> <tr><td>.75</td><td>3/4"</td></tr> <tr><td>1.06</td><td>1-1/16"</td></tr> <tr><td>1.50</td><td>1-1/2"</td></tr> <tr><td>2.00</td><td>2"</td></tr> <tr><td>2.50</td><td>2-1/2"</td></tr> <tr><td>3.00</td><td>3"</td></tr> </table> </div>	.75	3/4"	1.06	1-1/16"	1.50	1-1/2"	2.00	2"	2.50	2-1/2"	3.00	3"	<div style="border: 1px solid black; padding: 5px; width: fit-content; margin: 0 auto;">AR</div> <div style="border: 1px solid black; padding: 5px; width: fit-content; margin: 5px auto;"> <b>Mounting</b>  <table border="1" style="width: 100%; border-collapse: collapse;"> <tr><td>AR</td><td>Air Reservoir</td></tr> </table> </div>	AR	Air Reservoir	<div style="border: 1px solid black; padding: 5px; width: fit-content; margin: 0 auto;">SR</div>	<div style="border: 1px solid black; padding: 5px; width: fit-content; margin: 0 auto;">2.00</div> <div style="border: 1px solid black; padding: 5px; width: fit-content; margin: 5px auto;"> <b>Length</b>                  Specify in inches.                  See table below.             </div>
.75	3/4"																
1.06	1-1/16"																
1.50	1-1/2"																
2.00	2"																
2.50	2-1/2"																
3.00	3"																
AR	Air Reservoir																

Bore Size	Standard Lengths	Max. Length	Volume (in <sup>3</sup> )
3/4"	1" increments to 4"	32"	0.39 plus 0.44 per inch length
1-1/16"	1" increments to 8"	32"	0.99 plus 0.89 per inch length
1-1/2"	1" increments to 16"	32"	1.91 plus 1.77 per inch length
2"	1" increments to 16"	32"	4.22 plus 3.14 per inch length
2-1/2"	1" increments to 16"	32"	7.04 plus 4.91 per inch length
3"	1" increments to 16"	32"	9.90 plus 7.07 per inch length

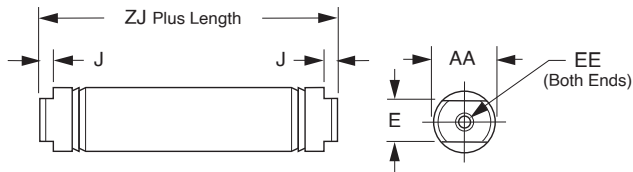

Bore Size	AA	E	EE	J	ZJ
3/4"	0.813	0.625	1/8" NPTF	0.19	1.938
1-1/16"	1.125	0.88	1/8" NPTF	0.19	2.375
1-1/2"	1.56	0.88	1/8" NPTF	0.250	2.250
2"	2.08	1.25	1/4" NPTF	0.312	2.875
2-1/2"	2.62	1.75	1/4" NPTF	0.312	2.875
3"	3.16	2.00	3/8" NPTF	0.312	3.190

C

Round Body Pneumatic Cylinders

SR/SRM/SRD/SRDM Series

SRG/SRGM Series

SRX Series

P1A Series

P Series



Options

Bumpers

Bumpers are available at extra cost except where noted as standard. Add the following dimensions to the overall cylinder length by bore.

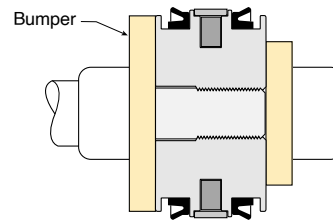

SR Bumper Adder

Cylinder Type	SR Series Bore Size											
	5/16"	7/16"	9/16"	3/4"	7/8"	1-1/16"	1-1/4"	1-1/2"	1-3/4"	2"	2-1/2"	3"
Spring Return	*	0.062"	0.062"	0.125"	*	0.125"	*	**	*	0.125"	N/A	N/A
Spring Extend	*	0.125"	0.062"	0.125"	*	0.125"	*	**	*	0.125"	N/A	N/A
Double Acting	*	0.188"	0.125"	**	*	0.125"	*	0.125"	*	0.250"	0.250"	N/A
K-type	N/A	0.250"	0.125"	**	*	0.250"	*	0.125"	*	0.250"	0.250"	N/A

\* Bumpers are furnished as standard and do not affect overall length.

\*\* Bumpers do not affect overall length.

SRM Bumper Adder

Cylinder Type	SRM Series Bore Size							
	9/16"	3/4"	1-1/16"	1-1/4"	1-1/2"	1-3/4"	2"	2-1/2"
Spring Return	0.062"	0.125"	0.125"	0.125"	0.125"	*	0.125"	N/A
Spring Extend	0.062"	0.125"	0.125"	0.125"	0.125"	*	0.125"	N/A
Double Acting	0.125"	0.250"	0.250"	0.250"	0.250"	*	0.250"	0.250"
K-type	0.125"	0.312"	0.250"	0.250"	0.250"	*	0.250"	0.250"

Fluorocarbon Seals

Available on all bore sizes at extra cost. Only available on SRM/SRDM for chemical compatibility, not high heat.

Rod Wiper

SR/SRM Series cylinders can be fitted with a rod wiper that is specially designed to prevent contaminants from clinging to the piston rod and damaging the piston rod seal. Available in 3/4", 1-1/16", and 1-1/2" bores, the piston rod wiper can be added to the SR/SRM and SRD/SRDM series.

Stainless Steel Piston Rods

Corrosion resistant stainless steel is the standard piston rod material for all bore sizes up to and including 1-1/2 inch bore at no additional cost. The only exception to the stainless steel standard is when a hollow rod, KDXH option is specified. Stainless steel is also the standard material on block, trunnion, hex/non-rotating and KDX mounts. Stainless steel is available on other sizes for an additional charge.

**C**  
 Round Body  
 Pneumatic Cylinders  
 SR/SRM/SRD/SRDM  
 Series  
 SRG/SRGM  
 Series  
 SRX  
 Series  
 P1A  
 Series  
 P  
 Series



For inventory, lead times, and kit lookup, visit [www.pdnplu.com](http://www.pdnplu.com)

Options

Adjustable Cushion Option

Cushions can be selected on nine bore sizes, ranging from 0.75" bore to 3.0" bore with mounting styles D, front nose mount, and DXP, rear pivot mount. Adjustable cushions are not available with double rod SR Series cylinders.

Cushion Adjusting Needle Valves

The fine-thread cushion needle valves make precise adjustment quick and easy. The needle valve is fully captured to allow for safe cushion adjustment while cylinder is pressurized. The brass needle valves are corrosion resistant. The standard position for needle valve adjustments is position 1, 90° from the port. See port location table for SR Series Cylinders.

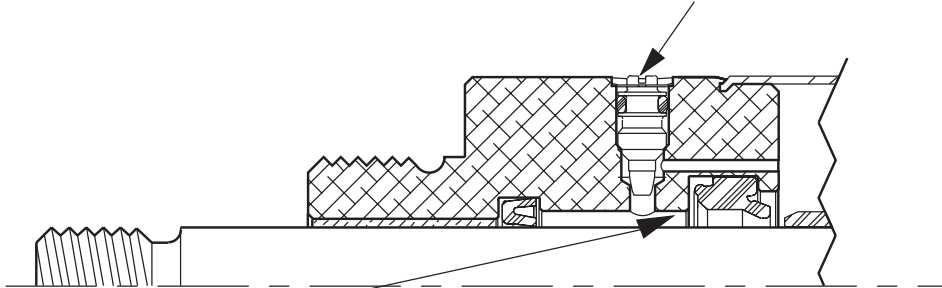

Check Seal Cushion

The "Check Seal" system offers excellent cushioning efficiency and long cushion seal life. This seal is specifically designed for cushion applications and has a long proven history in our products. Extensive side by side testing of the check seal in SR Series cylinders significantly outlasted and outperformed competitors' o-ring shaped seals.

The Check Seal's unique geometry exhibits the dynamic sealing capabilities of a lipseal. As the cushion sleeve enters the Check Seal at the end of stroke, the Check Seal blocks the air from exhausting directly through the port and forces the air through

the adjustable needle valve orifice. The exhaust airflow is precisely metered to control the desired rate of deceleration of the cylinder piston.

During stroke reversal, the check valve action of the Check Seal induces a fast out-of-cushion response. The Check Seal floats forward in the retainer groove as the cushion sleeve exits the Cushion Seal, thereby creating a path for maximum air flow around the Check Seal to access the piston face. The quick response of the Check Seal design yields faster cycle times and increased productivity.

Critical Mounting Dimensions for SR Series and SRM Cylinders with Adjustable Cushions

In most cases, cylinder mounting dimensions are not affected when cushions are specified. Standard catalog dimensions apply when cushions are specified at either end of a DXP mount and when specified at the head end only of a D mount. **The only exception to standard catalog dimensions is when a cushion is specified on the cap end or both ends of a D mount.** Please consult Table A for the critical mounting dimensions on D mount SR and SRM cylinders with cushions both ends or cushions cap end only.

Table B shows the cushion lengths for SR and SRM cylinders.

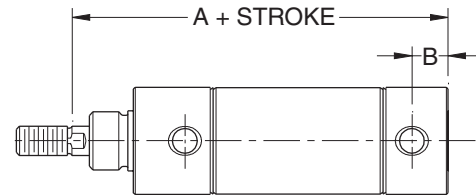

D Mount

Table A:  
Critical Mounting Dimensions for D Mount SR and SRM Cylinders with Cushions Both Ends or Cushions Cap End Only.

Bore Size	SR Dimensions		SRM Dimensions	
	A + Stroke	B	A + Stroke	B
.75	3.40	0.28	3.40	0.28
.88	3.25	0.28	N/A	N/A
1.06	3.49	0.28	3.65	0.28
1.25	4.31	0.38	4.34	0.38
1.50	3.88	0.31	4.12	0.31
1.75	5.25	0.42	5.53	0.42
2.00	5.06	0.47	5.34	0.47
2.50	5.06	0.47	5.06	0.47
3.00	5.69	0.53	N/A	N/A

Table B:  
Cushion Lengths for SR and SRM Cylinders.

Bore Size	Cushion Lengths	
	Head	Cap
.75	0.750	0.625
.88	0.750	0.625
1.06	0.750	0.625
1.25	0.750	0.625
1.50	0.750	0.625
1.75	0.875	0.625
2.00	0.875	0.750
2.50	0.875	0.750
3.00	0.875	1.000

C

Round Body Pneumatic Cylinders

SR/SRM/SRD/SRDM Series

SRG/SRGM Series

SRX Series

P1A Series

P Series



For inventory, lead times, and kit lookup, visit [www.pdnplu.com](http://www.pdnplu.com)

**Piston Rod Clevis**

Assembly includes pin and (2) retainer rings and (1) jam nut.

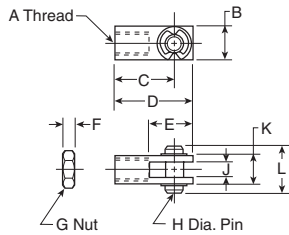

Bore Size	A	B	C	D	E	F	G	H	J	K	L	Part Number
5/16	#5-40	.31	.44	.56	.38	.11	#5-40	.12	.13	.31	.50	L071300025
7/16, 9/16	#10-32	.38	.75	.94	.56	.12	#10-32	.19	.19	.38	.56	L071300100 L077130100*
3/4, 7/8	1/4-28	.50	.94	1.19	.68	.16	1/4-28	.25	.25	.50	.69	L071300200 L077130200*
1-1/16	5/16-24	.50	.94	1.19	.68	.19	5/16-24	.25	.25	.50	.69	L071300300 L077130300*
1-1/4, 1-1/2	7/16-20	.75	1.31	1.69	.94	.25	7/16-20	.38	.38	.75	1.03	L071300400 L077130400*
1-3/4, 2, 2-1/2	1/2-20	.75	1.31	1.69	.94	.31	1/2-20	.38	.38	.75	1.03	L071300500 L077130500*
3	5/8-18	1.00	2.25	2.75	1.50	.38	5/8-18	.50	.50	1.00	1.38	L071300600

\* Stainless Steel for use with SRD/SRDM cylinders.

**Pivot Brackets**

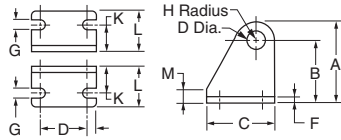

Bore Size	A	B	C	D	E	F	G	H	J	K	L	M	Part Number
7/16	.76	.56	.75	.50	.12	.06	.19	.20	.160	.28	.50	.12	L071310100
3/4, 7/8, 1-1/16	1.19	.88	1.12	.75	.19	.12	.27	.31	.255	.44	.81	.25	L071310200
1-1/2	1.75	1.38	1.50	1.00	.25	.12	.27	.38	.380	.62	1.00	.25	L071310300

**Pivot Bracket Assembly**

Assembly includes pin and (2) retainer rings.

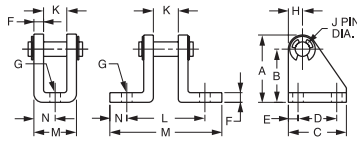

Bore Size	A	B	C	D	E	F	G	H	J	K	L	M	N	Part Number
5/16	.53	.40	.62	.38	.12	.04	16	.12	.12	.26	-	.36	.18	L071320025
7/16, 9/16	.76	.56	.75	.50	.12	.06	.19	.19	.156	.34	.91	1.34	.22	L071320100 L077150100*
3/4, 7/8, 1-1/16	1.18	.88	1.12	.75	.19	.12	.27	.30	.250	.38	1.25	2.00	.38	L071320200 L077150200*
1-1/4	1.18	.88	1.12	.75	.19	.12	.27	.30	.250	.50	1.38	2.14	.38	L071320300
1-1/2, 1-3/4	1.75	1.38	1.50	1.00	.25	.25	.27	.37	.375	.62	2.00	2.88	.44	L071320400 L077150400*
2, 2-1/2	1.75	1.38	1.50	1.00	.25	.25	.27	.37	.375	.75	2.12	3.00	.44	L071320500 L077150500*
3	2.25	1.75	1.75	1.25	.25	.25	.27	50	.50	.88	2.62	3.88	.62	L071320600

\* Stainless steel for use with SRD/SRDM cylinders.

**SR Series Trunnion Brackets**

Select brackets for SR series trunnion mount cylinders from the table below. (Note: trunnion brackets are ordered as a separate item from the cylinder.)

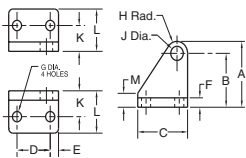

Bore Size	A	B	C	D	E	F	G	H	J	K	L	M	Part Number
7/16	1.75	1.38	1.50	1	.25	.25	.27	.38	.375	.69	1.12	.37	L076600100
3/4, 1-1/16, 1-1/2	1.75	1.38	1.50	1	.25	.25	.27	.38	.500	.69	1.12	.37	L076600200

Most popular.



For inventory, lead times, and kit lookup, visit [www.pdnplu.com](http://www.pdnplu.com)

Foot Brackets

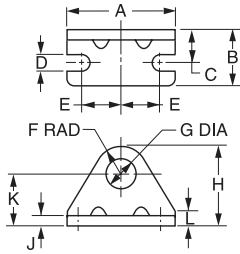

Bore Size	A	B	C	D	E	F	G	H	J	K	L	Part Number
5/16 †	1.00	.37	.25	.13	.37	.31	.25	.75	.06	.44	.12	L073790016
5/16	1.00	.37	.25	.13	.37	.31	.38	.75	.06	.44	.12	L073790023
7/16 †	1.38	.62	.31	.19	.50	.31	.38	.88	.07	.56	.12	L073790024
7/16, 9/16	1.38	.62	.38	.19	.50	.38	.44	.94	.09	.56	.12	L073790028 L077160028*
3/4 †	1.62	.75	.44	.19	.62	.41	.50	1.09	.10	.69	.19	L073790032
3/4, 7/8, 1-1/16	1.88	1.00	.56	.27	.75	.56	.63	1.38	.12	.81	.25	L073790040 L077160040*
1-1/4, 1-1/2	2.50	1.50	.75	.27	.94	.75	.75	1.75	.12	1.00	.38	L073790048 L077160048*
1-3/4	3.00	1.50	.87	.35	1.12	.91	1.03	2.16	.19	1.25	.50	L073790102
2	3.12	1.62	1.00	.34	1.12	1.00	1.38	2.50	.25	1.50	.62	L073790124 L077160124*
2-1/2	3.75	1.62	1.00	.35	1.44	1.25	1.51	3.00	.25	1.75	.75	L073790132
3	4.37	1.62	1.00	.35	1.75	1.25	1.64	3.14	.25	1.89	.89	L073790140

\* Stainless Steel for use with SRD/SRDM cylinders.  
† Used for spring return, non-ported head cylinders only.

Mounting Nut

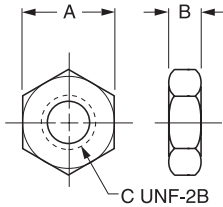

Bore Size	A	B	C	Part Number
5/16 †	.44	.16	1/4-28	L073800200
5/16, 7/16 †	.56	.22	3/8-24	L073800400
7/16, 9/16	.69	.25	7/16-20	L073800500 L077170500*
3/4 †	.75	.31	1/2-20	L073800600
3/4, 7/8, 1-1/16	.94	.38	5/8-18	L073800800 L077170800*
1-1/4, 1-1/2	1.12	.42	3/4-16	L073800900
1-1/4, 1-1/2	1.12	.72	3/4-16	L077170900*
1-3/4	1.50	.55	1-14	L073801100
2	1.88	.50	1-1/4-12	L073801200 L077171200*
2-1/2	2.06	.78	1-3/8-12	L073801400
3	2.25	.84	1-1/2-12	L073801500

\* Stainless Steel for use with SRD/SRDM cylinders.  
† Used for spring return, non-ported head cylinders only.

Most popular.



For inventory, lead times, and kit lookup, visit [www.pdnplu.com](http://www.pdnplu.com)

Features

SRG & SRGM Series

- 304 stainless steel cylinder body, non repairable construction
- 303 Stainless steel heads and caps
- 303 Stainless steel piston rod standard on all bore sizes
- Urethane rod wiper standard
- Available with bumpers and magnetic pistons
- Double acting models only
- Available with Nose, Foot and Pivot Mounts
- Corrosion resistant, reinforced plastic pivot bushing
- Not available with cushions
- Order mounting nut separately



Operating information

Operating pressure: 250 PSIG (17 bar) for SRG and SRGM  
 Temperature range: -10°F to 165°F (-23°C to 74°C) for SRG  
 14°F to 140°F (-10°C to 60°C) for SRGM  
 -10°F to 250°F (Fluorocarbon seals) for SRG  
 Filtration requirements: 40 micron, dry filtered air

Ordering Information

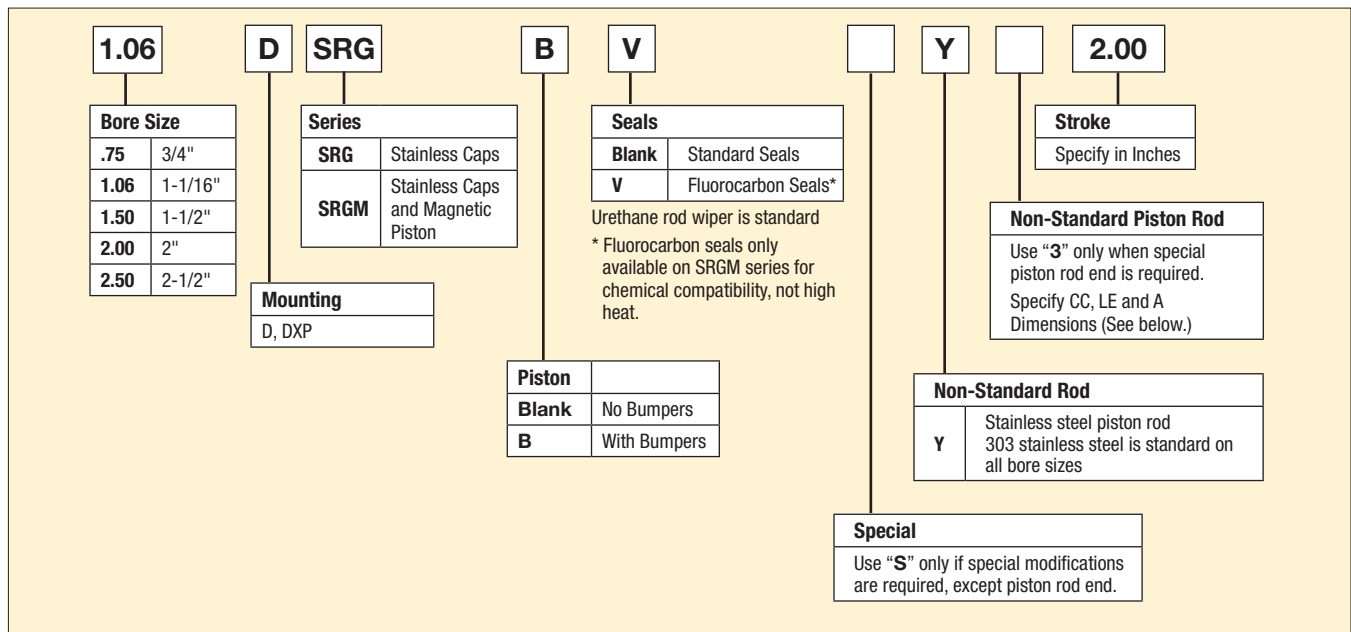

Non-Standard Rods

For non-standard rod dimensions, or undersized rod end threads, put a "3" in model number and describe the rod using the letters shown in the drawing. Specify CC, LE and A dimensions. LE is measured in retracted position.

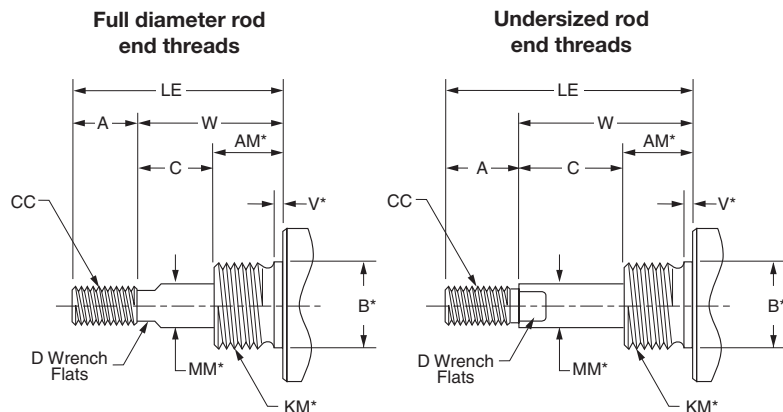

\* Requires an S designation in model number.



For inventory, lead times, and kit lookup, visit [www.pdnplu.com](http://www.pdnplu.com)

Round Body Pneumatic Cylinders  
 SR/SRM/SRD/SRDM Series  
 SRG/SRGM Series  
 SRX Series  
 P1A Series  
 P Series

Mounting Style – D

Mounting Style D

Nose mount, double acting

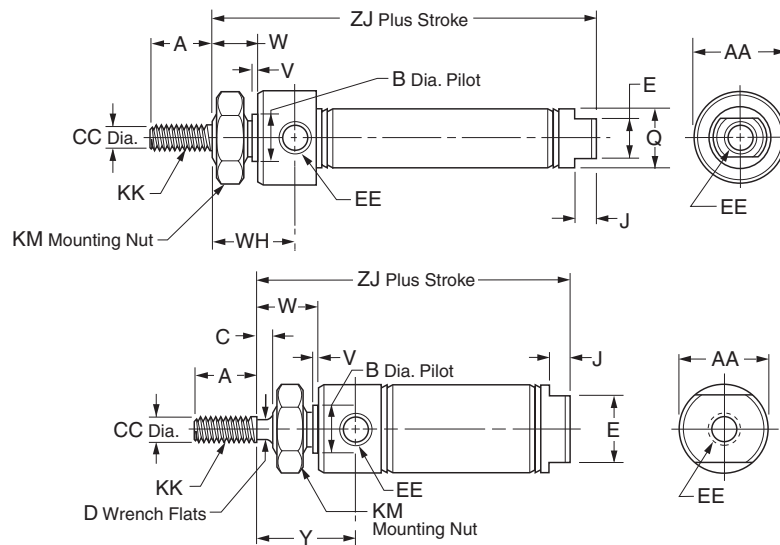

Bore Sizes †

3/4" \*

Bore Sizes †

1-1/16" \*

1-1/2" \*

2" \*

2-1/2" \*

\* No mounting nuts

† Mounting nuts sold separately for all series SRG

Bore Size	Std. Stroke (in)	Max. Stroke (in)	SS Rod Std	A	AA	B	C	CC	D
3/4"	1/2, 1, 2, 2-1/2, 3, 4, 5, 6, 8, 10	12	✓	0.50	0.86	0.624	-	0.250	-
1-1/16"	1/2, 1, 1-1/2, 2, 2-1/2, 3, 4, 5, 6, 8, 10, 12	12	✓	0.50	1.12	0.624	0.12	0.312	0.25
1-1/2"	1/2, 1, 2, 3, 4, 5, 6, 8, 10, 12	12	✓	0.75	1.56	0.749	0.25	0.437	0.38
2"	-	12	✓	0.88	2.08	1.374	0.38	0.625	0.50
2-1/2"	-	12	✓	0.88	2.62	1.500	0.38	0.625	1/2

Bore Size	E	EE	J	KK	KM	Q	V	W	WH	Y	ZJ	
											SRG	SRGM
3/4"	0.62	1/8 NPTF	0.19	1/4-28 UNF	5/8-18	0.81	0.09	0.50	0.97	-	2.97	2.97
1-1/16"	0.88	1/8 NPTF	0.19	5/16-24 UNF	5/8-18	-	0.09	0.62	-	1.19	3.25	3.41
1-1/2"	0.88	1/8 NPTF	0.25	7/16-20 UNF	3/4-16	-	0.09	0.88	-	1.50	3.69	3.94
2"	1.25	1/4 NPTF	0.31	1/2-20 UNF	1-1/4-12	-	0.12	1.19	-	1.88	4.69	4.97
2-1/2"	1.75	1/4 NPTF	0.31	1/2-20 UNF	1-3/8-12	-	0.13	1.19	-	1.84	4.69	4.69

† Mounting nuts sold separately for all series SRG

**C**

Round Body  
Pneumatic Cylinders

---

SR/SRM/SRD/SRDM  
Series

---

SRG/SRGM  
Series

---

SRX  
Series

---

P1A  
Series

---

P  
Series



For inventory, lead times, and kit lookup, visit [www.pdnplu.com](http://www.pdnplu.com)

**Style DXP**

Pivot & nose mount, double acting, no pivot pin

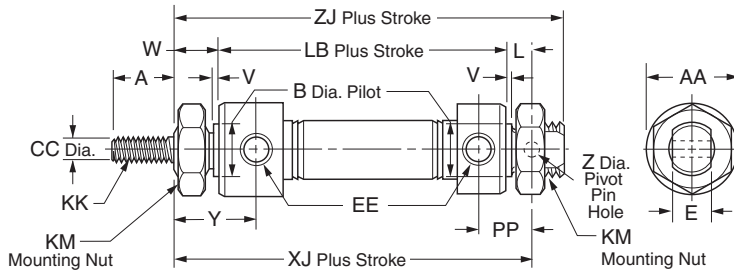

Bore Sizes †
3/4" *

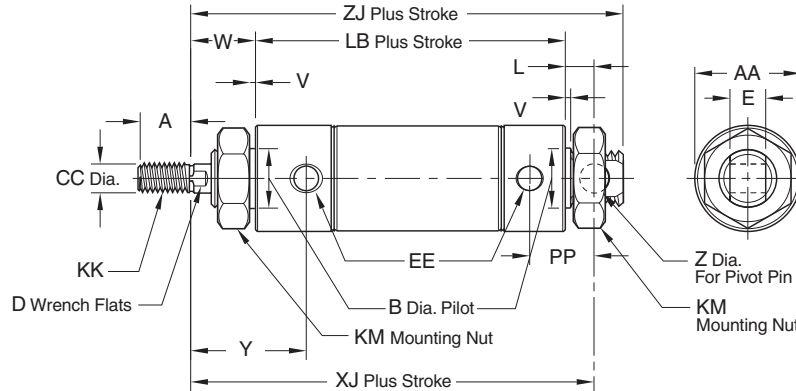

Bore Sizes †
1-1/16" *
1-1/2" *
2" *
2-1/2" *

\* No mounting nuts  
 † Mounting nuts sold separately for all series SRG

Bore Size	Std. Stroke (in)	Max. Stroke (in)	SS Rod Std	A	AA	B	CC	D	E	EE
3/4"	1, 2, 3, 4, 5, 6, 8, 10	32	✓	0.50	0.86	0.624	0.250	-	0.38	1/8 NPTF
1-1/16"	1/2, 1, 1-1/2, 2, 2-1/2, 3, 4, 5, 6, 8, 10, 12	32	✓	0.50	1.12	0.624	0.312	0.25	0.38	1/8 NPTF
1-1/2"	-	32	✓	0.75	1.56	0.749	0.437	0.38	0.62	1/8 NPTF
2"	-	32	✓	0.88	2.08	1.374	0.625	0.50	0.75	1/4 NPTF
2-1/2"	-	32	✓	0.88	2.62	1.500	0.625	1/2	0.75	1/4 NPTF

Bore Size	XJ							SRG		SRGM		ZJ	
	KK	KM	L	LB	PP	V	W	SRG	SRGM	Y	Z	SRG	SRGM
3/4"	1/4-28 UNF	5/8-18	0.34	2.91	0.62	0.09	0.50	3.75	3.75	0.97	0.251	4.03	4.03
1-1/16"	5/16-24 UNF	5/8-18	0.34	-	0.62	0.09	0.62	3.84	-	1.19	0.251	4.12	4.28
1-1/2"	7/16-20 UNF	3/4-16	0.50	-	0.81	0.09	0.88	4.38	4.63	1.50	0.376	4.75	5.00
2"	1/2-20 UNF	1-1/4-12	0.56	-	1.03	0.12	1.19	5.62	5.91	-	0.376	6.06	6.34
2-1/2"	1/2-20 UNF	1-3/8-12	0.56	-	1.03	0.13	1.19	5.62	5.62	1.84	0.376	6.06	6.06

† Mounting nuts sold separately for all series SRG

**C**  
 Round Body Pneumatic Cylinders  
 SR/SRM/SRD/SRDM Series  
 SRG/SRGM Series  
 SRX Series  
 P1A Series  
 P Series



For inventory, lead times, and kit lookup, visit [www.pdnplu.com](http://www.pdnplu.com)



**Piston Rod Clevis**

Assembly includes pin and (2) retainer rings and (1) jam nut.

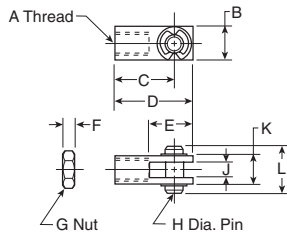

Bore Size	A	B	C	D	E	F	G	H	J	K	L	Part Number
3/4	1/4-28	.50	.94	1.19	.68	.16	1/4-28	.25	.25	.50	.69	L077130200
1-1/16	5/16-24	.50	.94	1.19	.68	.19	5/16-24	.25	.25	.50	.69	L077130300
1-1/2	7/16-20	.75	1.31	1.69	.94	.25	7/16-20	.38	.38	.75	1.03	L077130400
2, 2-1/2	1/2-20	.75	1.31	1.69	.94	.31	1/2-20	.38	.38	.75	1.03	L077130500

**Pivot Bracket Assembly**

Assembly includes pin and (2) retainer rings.

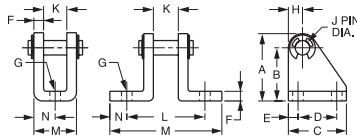

Bore Size	A	B	C	D	E	F	G	H	J	K	L	M	N	Part Number
3/4, 1-1/16	1.18	.88	1.12	.75	.19	.12	.27	.30	.250	.38	1.25	2.00	.38	L077150200
1-1/2	1.75	1.38	1.50	1.00	.25	.25	.27	.37	.375	.62	2.00	2.88	.44	L077150400
2, 2-1/2	1.75	1.38	1.50	1.00	.25	.25	.27	.37	.375	.75	2.12	3.00	.44	L077150500

Stainless steel.

**Foot Brackets**

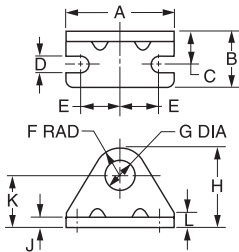

Bore Size	A	B	C	D	E	F	G	H	J	K	L	Part Number
3/4, 1-1/16	1.88	1.00	.56	.27	.75	.56	.63	1.38	.12	.81	.25	L077160040
1-1/2	2.50	1.50	.75	.27	.94	.75	.75	1.75	.12	1.00	.38	L077160048
2	3.12	1.62	1.00	.34	1.12	1.00	1.38	2.50	.25	1.50	.62	L077160124
2-1/2	3.75	1.62	1.00	.35	1.44	1.25	1.51	3.00	.25	1.75	.75	L077160132

Stainless steel.

**Mounting Nut**

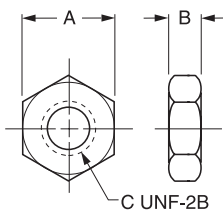

Bore Size	A	B	C	Part Number
3/4, 1-1/16	.94	.38	5/8-18	L077170800
1-1/2	1.12	.42	3/4-16	L077170900
2	1.88	.50	1-1/4-12	L077171200
2-1/2	2.06	.78	1-3/8-12	L077171400

Stainless steel.



Round Body  
Pneumatic Cylinders

SR/SRM/SRD/SRDM  
Series

SRG/SRGM  
Series

SRX  
Series

P1A  
Series

P  
Series



For inventory, lead times, and kit lookup, visit [www.pdnplu.com](http://www.pdnplu.com)

**Features**

**SRX Series**

C	Round Body Pneumatic Cylinders
	SR/SRM/SRD/SRDM Series
	SRG/SRGM Series
	SRX Series
	P1A Series
	P Series

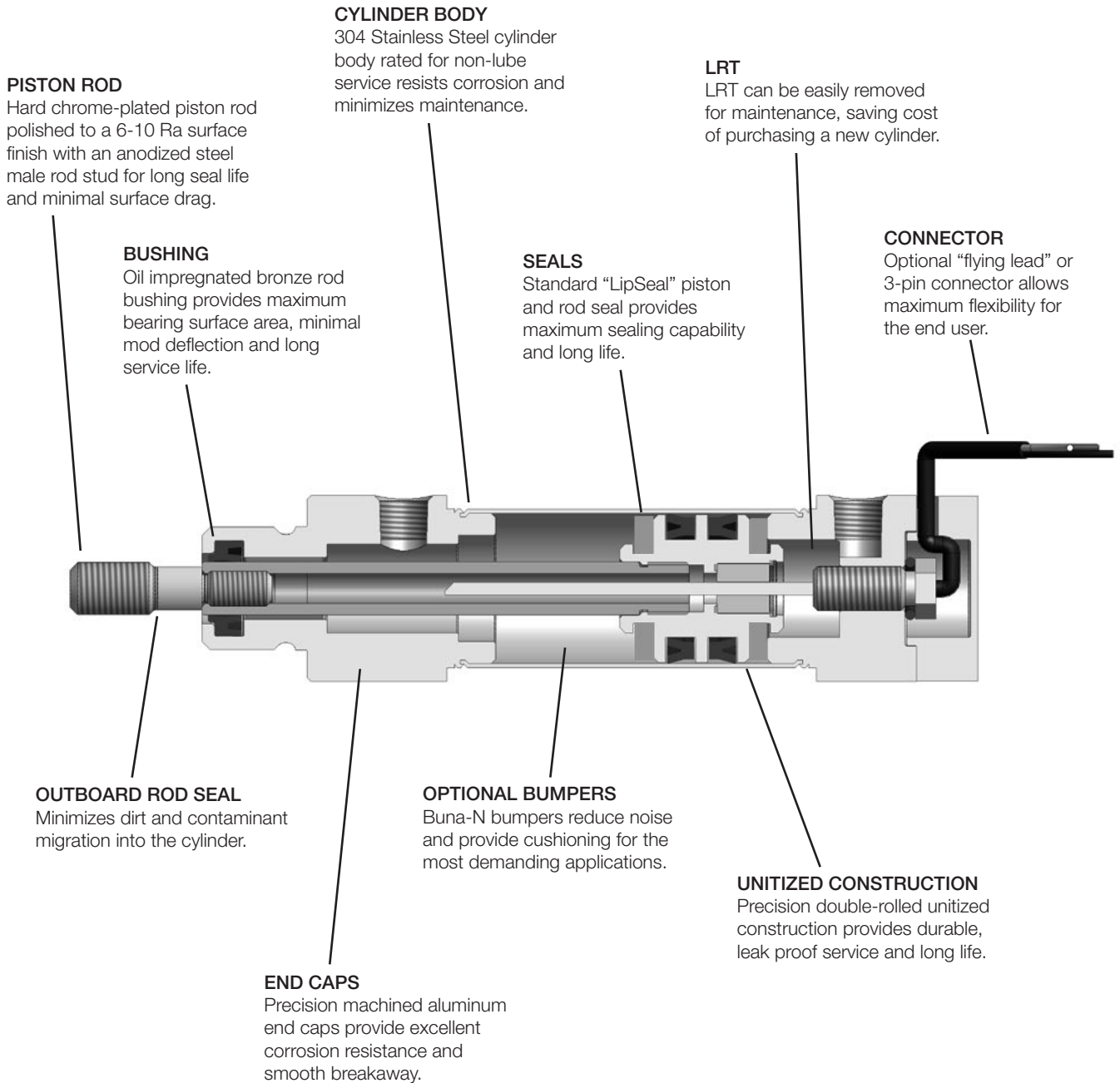

For inventory, lead times, and kit lookup, visit [www.pdnplu.com](http://www.pdnplu.com)

## Features

- Continuous position feedback
- Bore sizes: 1-1/16" to 3"
- Signal input: 5 to 24 VDC
- Signal output (w/o controls): DC ratiometric voltage\*
- Signal output (w/controls): 0 to 10 VDC or 4 to 20 mA
- Strokes: Available in any practical stroke length up to 24"

\* Mega Ohm impedance interface device suggested for limiting sensor current if controller is not used.



### Operating information

Operating pressure:	150 PSIG (10.3 bar)
Temperature range:	40°F to 160°F (4.4°C to 71°C)
Filtration requirements:	40 micron, dry filtered air

### Ordering Information

<b>1.50"</b>	<b>DXP</b>	<b>P</b>	<b>SRX</b>	<b>B</b>	<b>S</b>	<b>3</b>	<b>6.00"</b>
<b>Bore Size</b>		<b>Connector Style</b>		<b>Piston</b>	<b>Special</b>		<b>Stroke</b>
1.06"		<b>P</b> Plug		<b>B</b> Bumper*	<b>S</b> Special		Stroke in Inches
1.50"		<b>F</b> Flying Leads		Leave blank if not required.	Leave blank if special modification is not required.		
2.00"							
2.50"							
3.00"							
	<b>Mounting Style</b>					<b>Non-Standard Rod Dimension</b>	
	<b>D</b> Nose Mount					<b>3</b> Non-Standard Dimension	
	<b>DXP</b> Nose and Pivot Mount					Leave blank if special rod end dimension is not required.	
	<b>BFD</b> Front Block Mount						

\* Incorporating bumpers adds 1/4" of overall length to the cylinder.

**Sensors**  
See section L for sensors.

**NOTE:** For non-standard / special rod ends, see below.

For ordering purposes, when special options or common modifications are requested, the factory will assign a sequential part number in place of the model number.

### Non-standard rods

For non-standard rod dimensions, or undersized rod end threads, put a "3" in model number and describe the rod using the letters shown in the drawing. It is necessary to specify only those dimensions that are non-standard. LE is measured in retracted position.

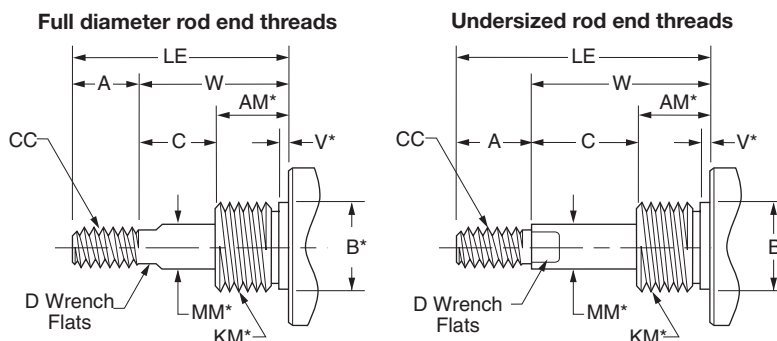

\* Requires an "S" designation in model number.

C	Round Body Pneumatic Cylinders
	SR/SRM/SRD/SRDM Series
	SRG/SRGM Series
	SRX Series
	P1A Series
	P Series



For inventory, lead times, and kit lookup, visit [www.pdnplu.com](http://www.pdnplu.com)

**General Specifications**

- Bore sizes: 1-1/16", 1-1/2", 2", 2-1/2", 3"
- Rod sizes: 0.38" – 0.75"
- Rod ends: Standard male
- Mounts:
  - Nose mount (D)
  - Front block mount (BFD)
  - Nose and pivot mount (DXP)
- Rated air pressure: 150 PSI Air
- Standard temperature: 40°F to 160°F
- Strokes: Available in any practical stroke length up to 24", 1/2" minimum stroke
- Bumpers: Optional
- Not available with fluorocarbon seals

**Available Mountings**



**Style D**  
**Nose Mount**

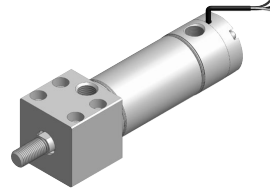

**Style BFD**  
**Front Block Mount**



**Style DXP**  
**Nose and Pivot Mount**

**Theory of Operation**

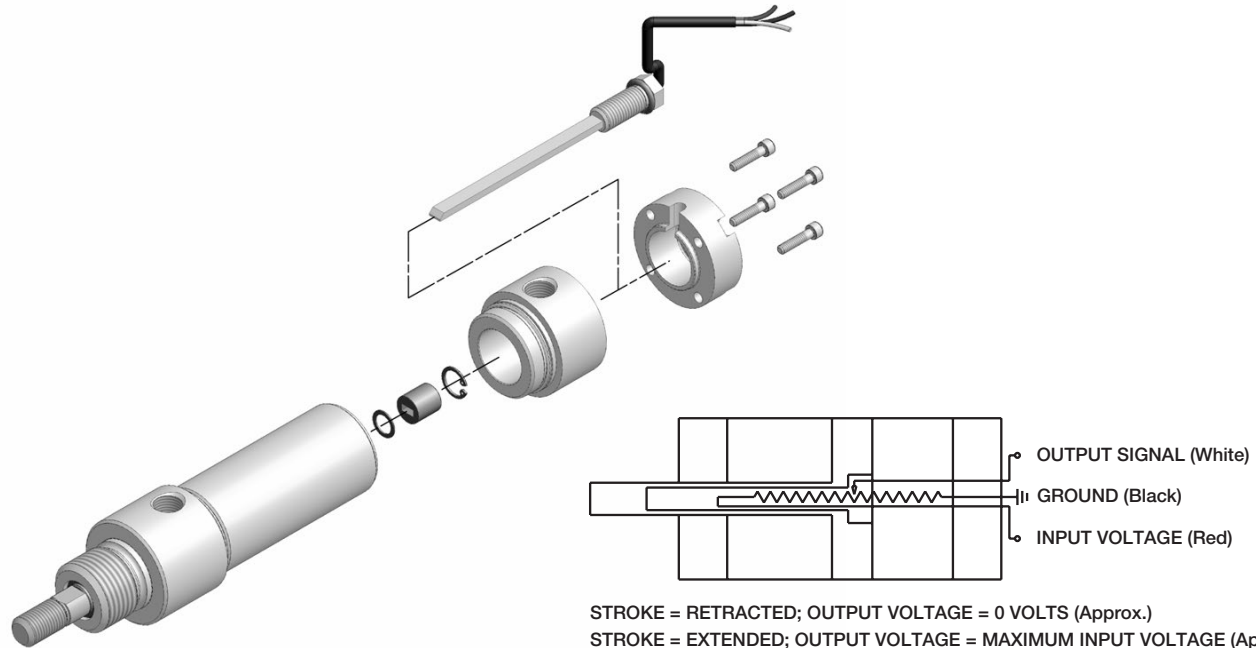

The SRX Series Linear Resistive Transducer (LRT) is a position sensor that uses a resistive element, and wiper assembly, to provide a continuous analog output signal relative to the cylinders position. The LRT is a single element type linear potentiometer, with two independent elements mounted on either side of an anodized aluminum extrusion. The LRT operates as a voltage divider by creating a short between the wiper extrusion and the wiper assembly. The position of the wiper changes the resistive load proportionally to its position along the stroke length of the cylinder.

Supplying a 5 to 24VDC voltage energizes the LRT. As the cylinder travels through its range of stroke, the resistive load changes, thus causing a proportional voltage output change of the LRT. The output voltage, at the endpoint of cylinder stroke, is dictated by the input voltage applied across the device.

The probe is mounted into the cap end of the cylinder and inserted into the hollow piston rod assembly. When replacing the probe, care must be taken to align the wiper block with the profile of the LRT extrusion. Please review the above schematic and cutaway drawing for reference purposes.

C	Round Body Pneumatic Cylinders
	SR/SRM/SRD/SRDM Series
	SRG/SRGM Series
	SRX Series
	P1A Series
	P Series

**MLRT**

Repeatability	±0.001" (interface electronics dependent)
Non Linearity	±1% of Full stroke (24" stroke max.)
Resolution	Infinite
Signal Input	5 to 24 VDC
Signal Output (w/o controls):	DC ratiometric voltage*
Signal Output (w/ controls):	0 to 10 VDC or 4 to 20 mA
Maximum Speed	50" per second
Rated Life of MLRT	500 Million inches of wiper travel
Pressure Rating	150 psi
Temperature Rating	40°F to 165°F
Resistance Rating	1,000 Ohms per inch ±20%
Connection Options	6" Flying leads or 3-pin nano connector

\* 1 Mega Ohm impedance interface device suggested for limiting sensor current if the controller is not used.

**MLRT Circuit Diagram**

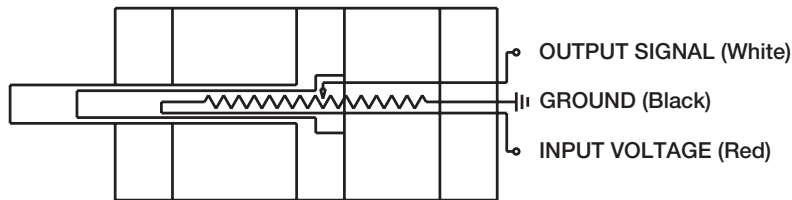

STROKE = RETRACTED; OUTPUT VOLTAGE = 0 VOLTS (Approx.)  
 STROKE = EXTENDED; OUTPUT VOLTAGE = MAXIMUM INPUT VOLTAGE (Approx.)



Round Body  
 Pneumatic Cylinders

SR/SRM/SRD/SRDM  
 Series

SRG/SRGM  
 Series

SRX  
 Series

P1A  
 Series

P  
 Series



1-1/16" Bore Cylinders

Style D

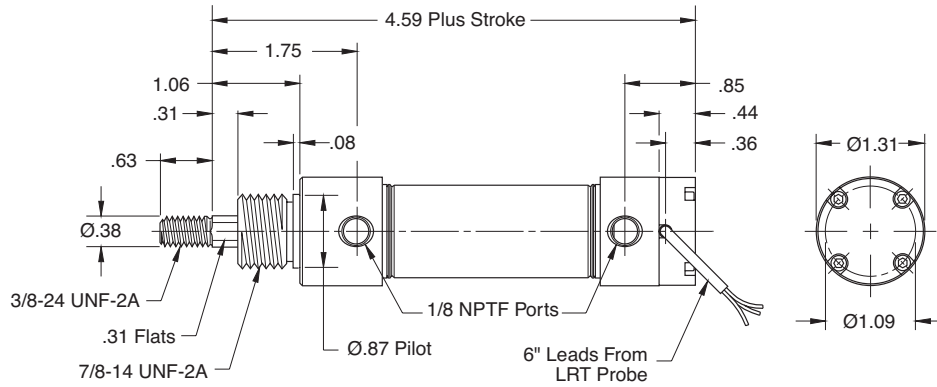

Style DXP

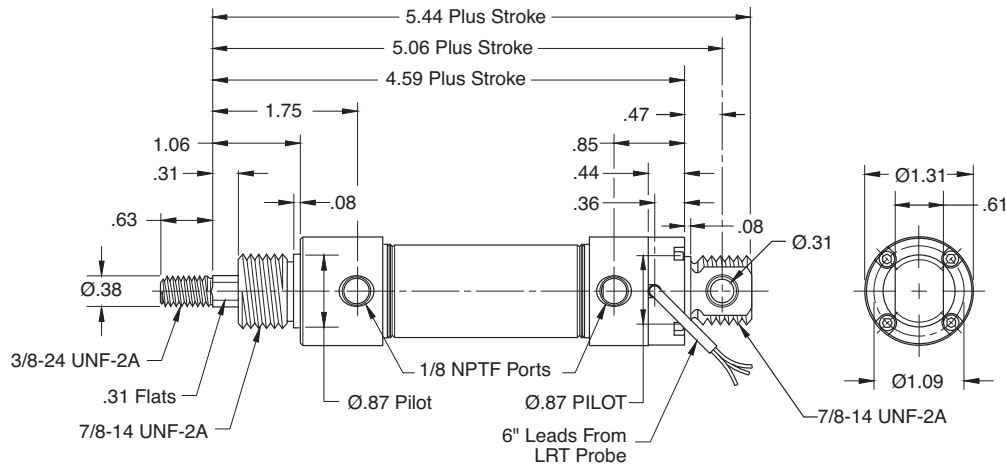

Style BFD

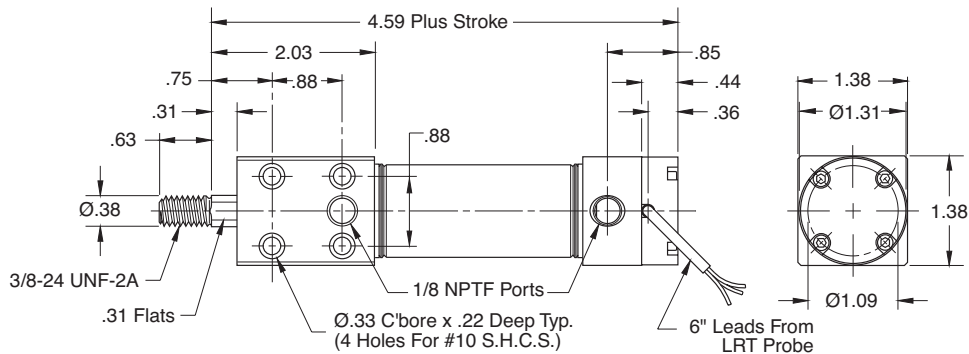

C	Round Body Pneumatic Cylinders
	SR/SRM/SRD/SRDM Series
SRG/SRGM	SRG/SRGM Series
	SRX Series
P1A	P1A Series
	P Series



For inventory, lead times, and kit lookup, visit [www.pdnplu.com](http://www.pdnplu.com)

1-1/2" Bore Cylinders

Style D

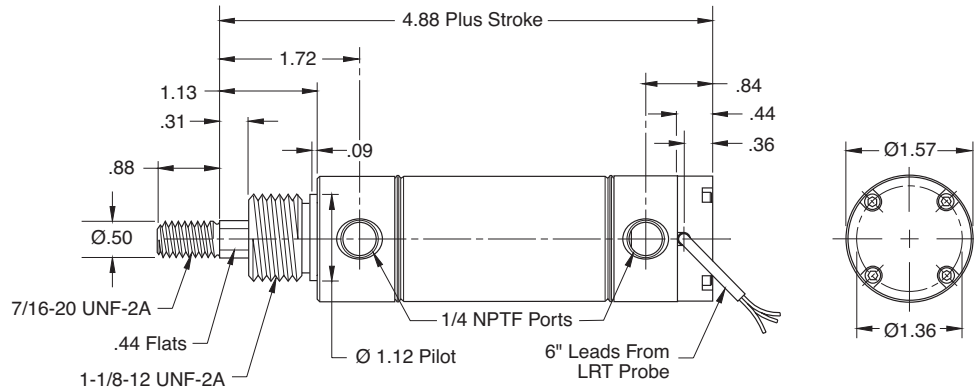

Style DXP

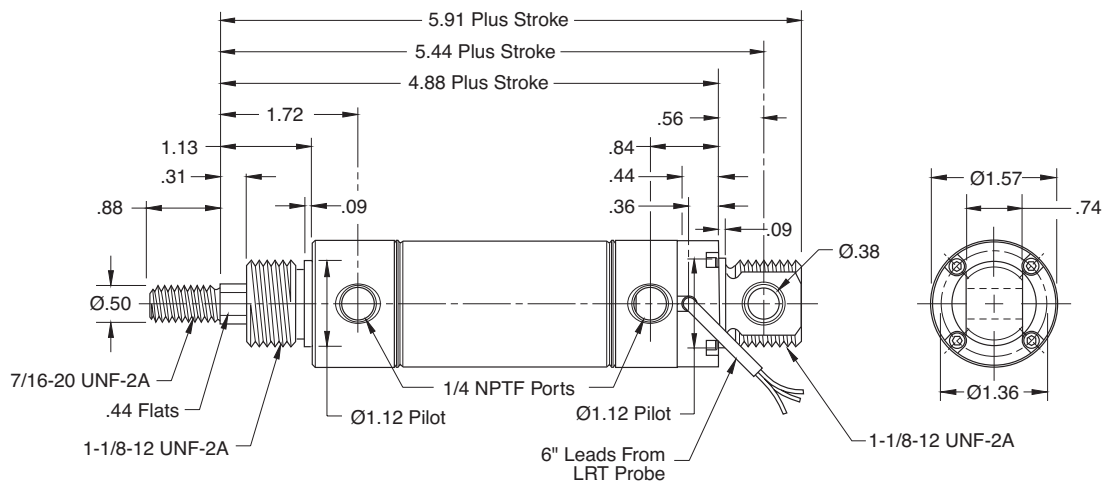

Style BFD

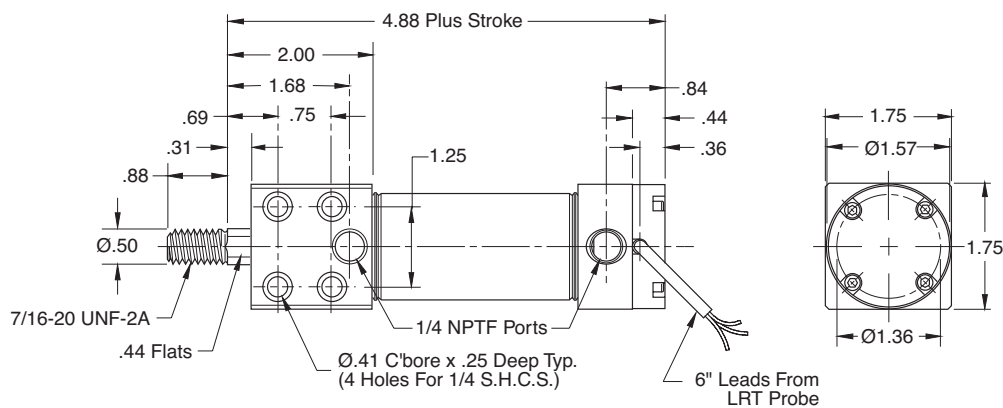

C	Round Body Pneumatic Cylinders
	SR/SRM/SRD/SRDM Series
SRG/SRGM	Series
SRX	Series
P1A	Series
P	Series



2" Bore Cylinders

Style D

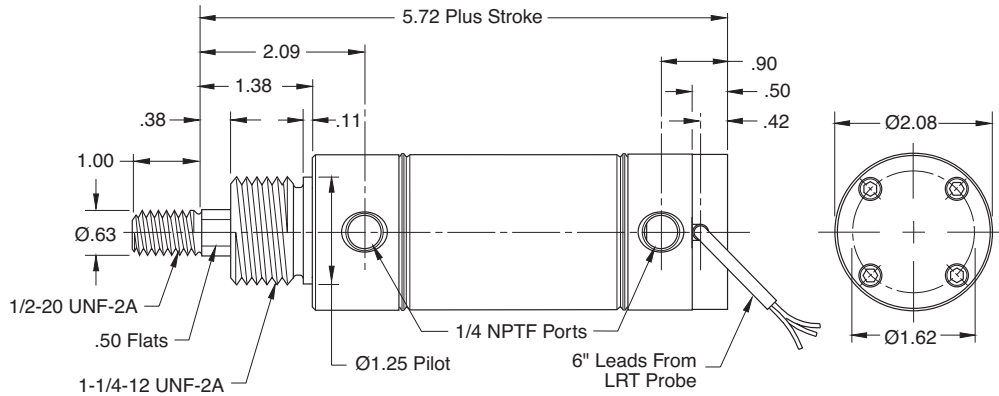

Style DXP

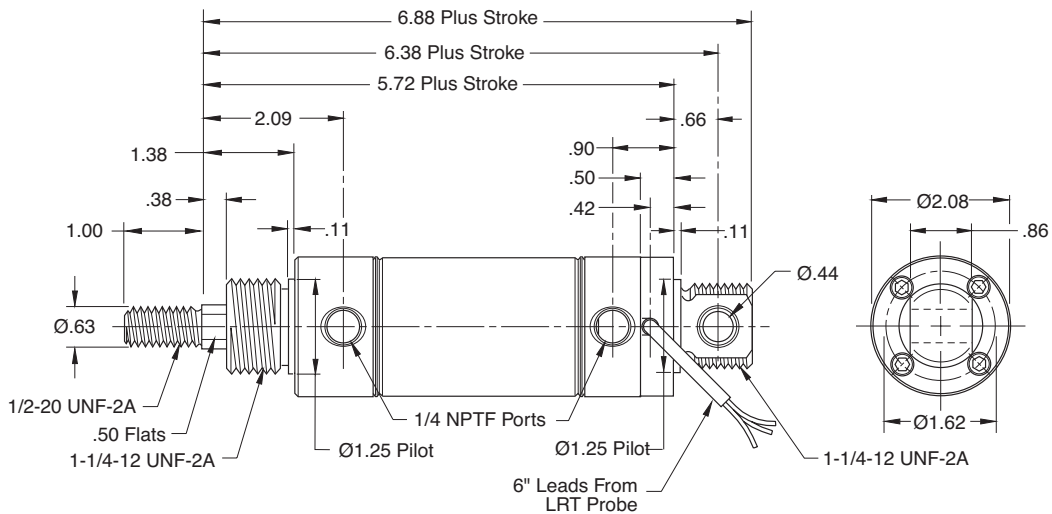

Style BFD

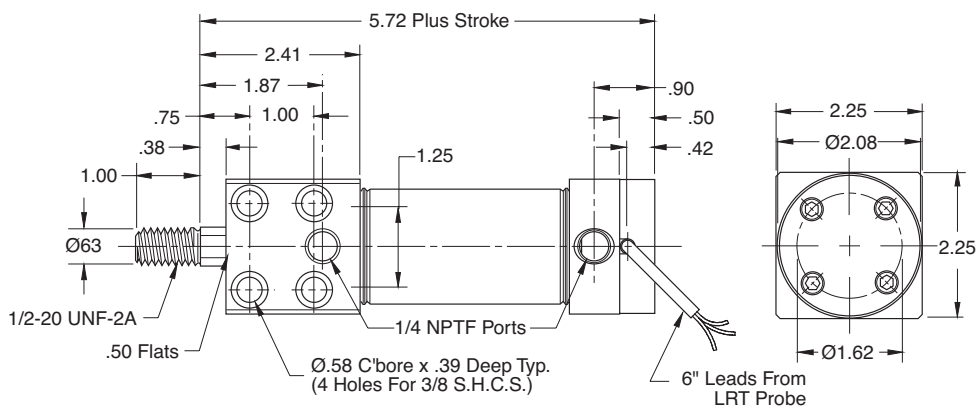

C	Round Body Pneumatic Cylinders
	SR/SRM/SRD/SRDM Series
SRG/SRGM	SRG/SRGM Series
	SRX Series
P1A	P1A Series
P	P Series



For inventory, lead times, and kit lookup, visit [www.pdnplu.com](http://www.pdnplu.com)

C44

Parker Hannifin Corporation  
Pneumatic Division  
Wadsworth, Ohio  
[www.parker.com/pneumatics](http://www.parker.com/pneumatics)

2-1/2" Bore Cylinders

Style D

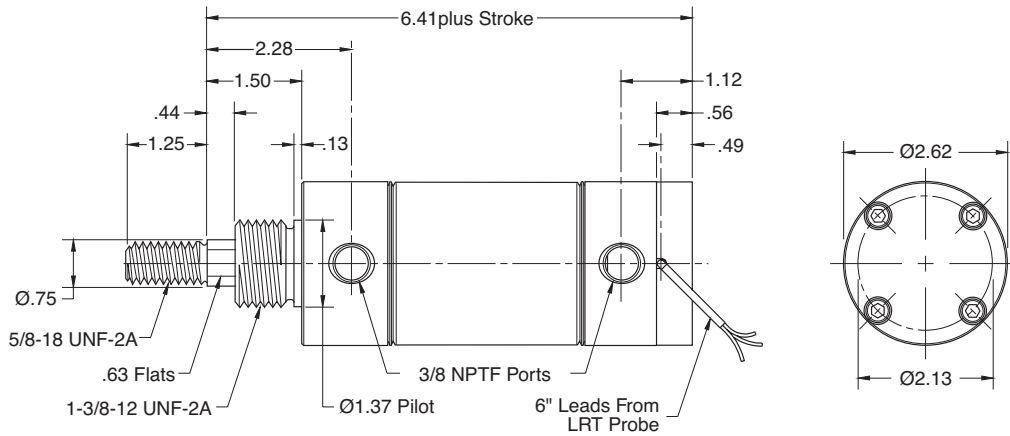

Style DXP

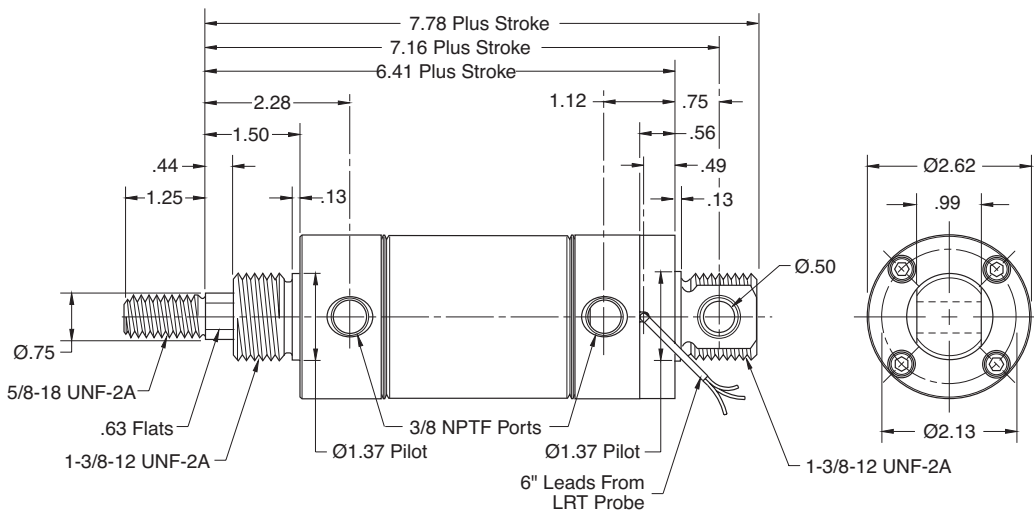

Style BFD

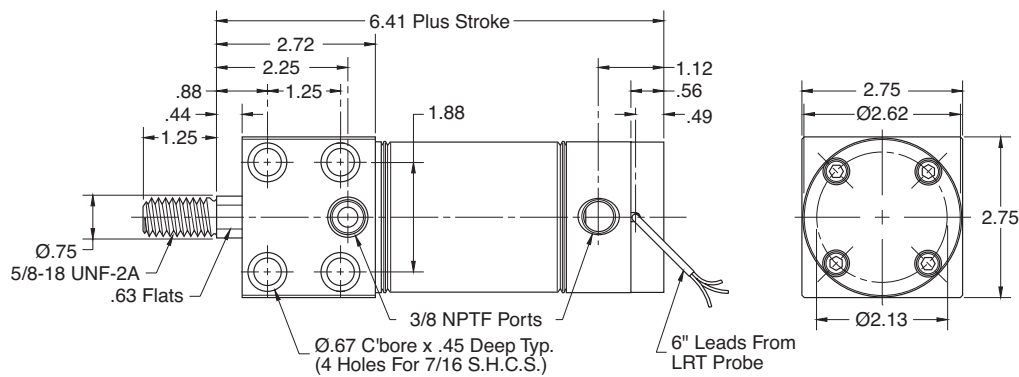

	Round Body Pneumatic Cylinders
SR/SRM/SRD/SRDM Series	SRG/SRGM Series
SRX Series	P1A Series
P Series	

3" Bore Cylinders

Style D

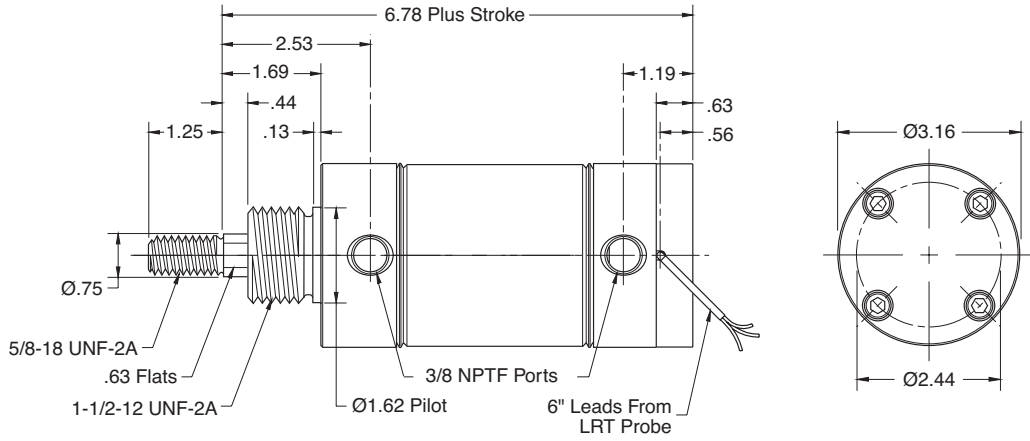

Style DXP

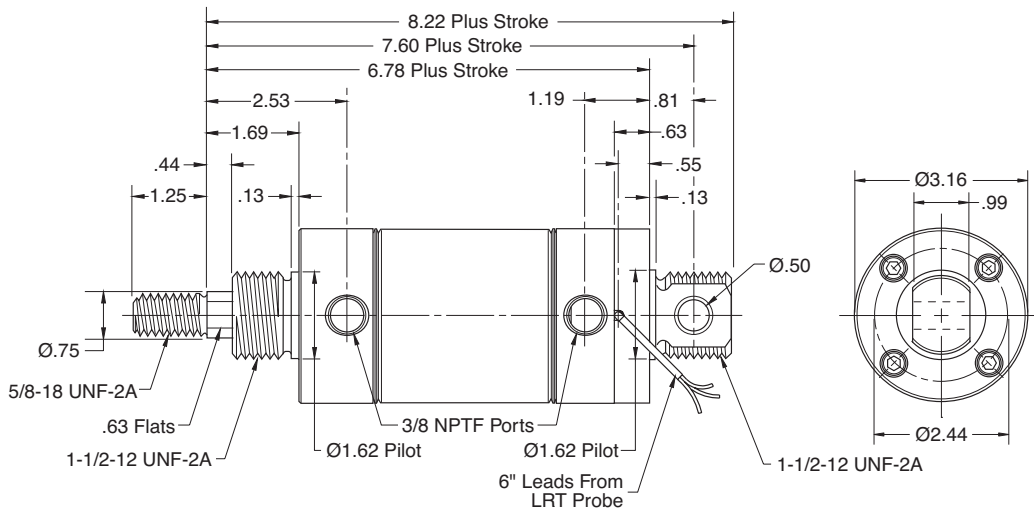

Style BFD

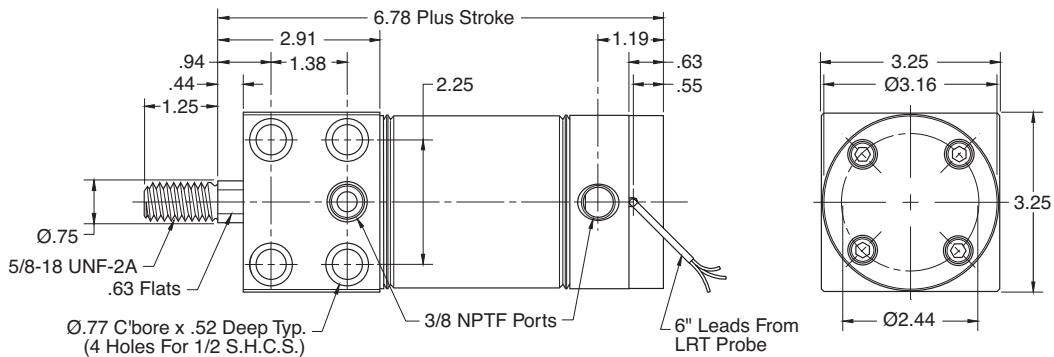

C	Round Body Pneumatic Cylinders
	SR/SRM/SRD/SRDM Series
SRG/SRGM	SRG/SRGM Series
	SRX Series
P1A	P1A Series
	P Series



For inventory, lead times, and kit lookup, visit [www.pdnplu.com](http://www.pdnplu.com)

Piston Rod Clevis

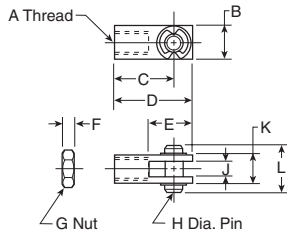

Bore Size	A	B	C	D	E	F	G	H	J	K	L	Part Number
1-1/16	3/8-24	.63	1.38	1.69	.94	.22	3/8-24	.31	.32	.63	.88	L071300350
1-1/2	7/16-20	.75	1.31	1.69	.94	.25	7/16-20	.38	.38	.75	1.03	L071300400
2	1/2-20	.88	1.88	2.31	1.31	.31	1/2-20	.44	.45	.88	1.14	L071300550
2-1/2, 3	5/8-18	1.00	2.25	2.75	1.50	.38	5/8-18	.50	.51	1.00	1.38	L071300600

Pivot Brackets

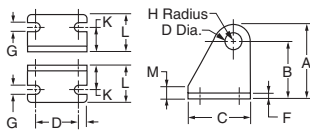

Bore Size	A	B	C	D	E	F	G	H	J	K	L	M	Part Number
1-1/16	1.31	1.00	1.31	.81	.25	.16	.28	.31	.315	.56	.88	.28	L071310400
1-1/2	1.63	1.25	1.63	1.00	.31	.19	.34	.38	.378	.69	1.13	.31	L071310500
2	1.81	1.38	1.81	1.19	.31	.25	.34	.44	.440	.75	1.19	.38	L071310600
2-1/2, 3	2.13	1.63	2.13	1.38	.38	.25	.41	.50	.503	.88	1.38	.38	L071310700

Pivot Brackets

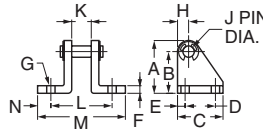

Bore Size	A	B	C	D	E	F	G	H	J	K	L	M	N	Part Number
1-1/16	1.31	1.00	1.31	.81	.25	.16	.28	.31	.312	.62	1.75	2.38	.31	L071320250
1-1/2	1.63	1.25	1.63	1.00	.31	.19	.34	.38	.375	.75	2.13	3.00	.44	L071320350
2	1.81	1.38	1.81	1.19	.31	.25	.34	.44	.437	.88	2.38	3.25	.44	L071320450
2-1/2, 3	2.13	1.63	2.13	1.38	.38	.25	.41	.50	.500	1.00	2.75	3.75	.50	L071320550

Foot Brackets

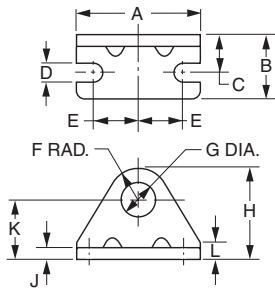

Bore Size	A	B	C	D	E	F	G	H	J	K	L	Part Number
1-1/16	2.13	1.16	.66	.28	.75	.75	.88	1.75	.16	1.00	.38	L073790056
1-1/2	2.75	1.44	.81	.35	1.00	.94	1.13	2.19	.19	1.25	.38	L073790108
2	3.00	1.59	.91	.35	1.19	1.06	1.26	2.44	.22	1.38	.44	L073790116
2-1/2	3.75	1.88	1.06	.41	1.50	1.19	1.38	2.81	.25	1.63	.50	L073790125
3	4.38	1.62	1.00	.35	1.75	1.25	1.64	3.14	.25	1.89	.89	L073790140

Mounting Nut

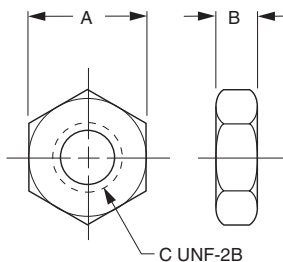

Bore Size	A	B	C	Part Number
1-1/16	1.31	.48	7/8-14	L073801000
1-1/2	1.69	.61	1-1/8-12	L073801300
2	1.88	.50	1-1/4-12	L073801200
2-1/2	2.06	.78	1-3/8-12	L073801400
3	2.25	.84	1-1/2-12	L073801500

Most popular.



For inventory, lead times, and kit lookup, visit [www.pdnplu.com](http://www.pdnplu.com)

**3-pin Nano Connector**

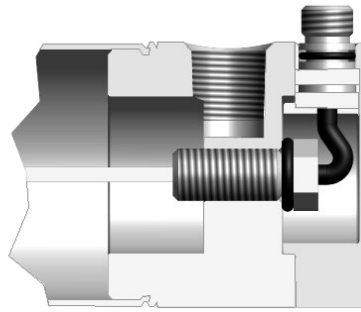
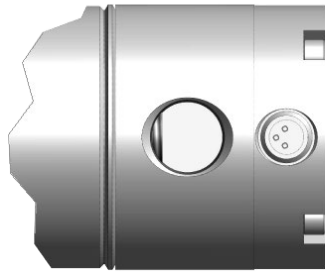

**Wire Color**

Wires	6" Leads	Plug Option
Input	Red	Brown
Ground	Black	Blue
Output	White	Black

**Connectors**

Cable Length	Threaded Straight Connector	Threaded Right Angle Connector
5 meters	<b>086620T005</b>	<b>086620R005</b>
2 meters	<b>086620T002</b>	<b>086620R002</b>

**Straight Connector**

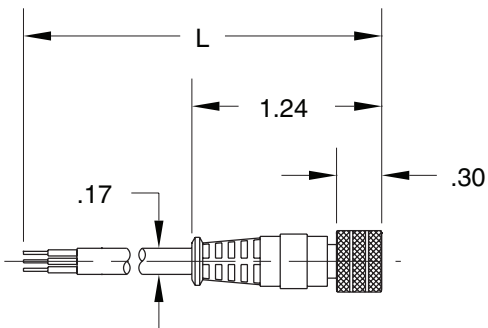

**Right-angle Connector**

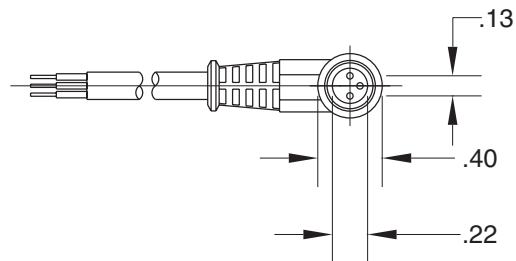
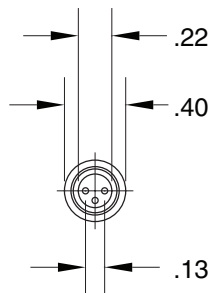
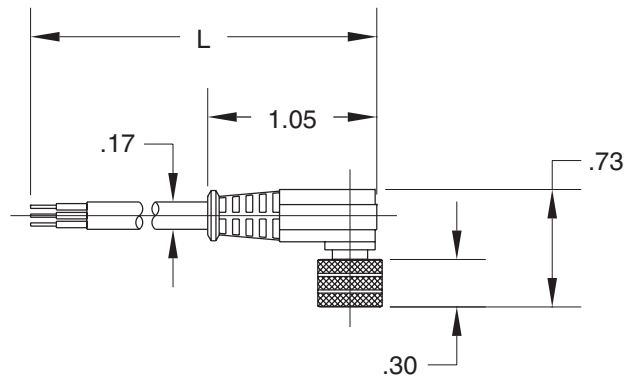

**C**

Round Body  
Pneumatic Cylinders

SR/SRM/SRD/SRDM  
Series

SRG/SRGM  
Series

SRX  
Series

P1A  
Series

P  
Series

**Dual Set Point Controller, Part #149344000**

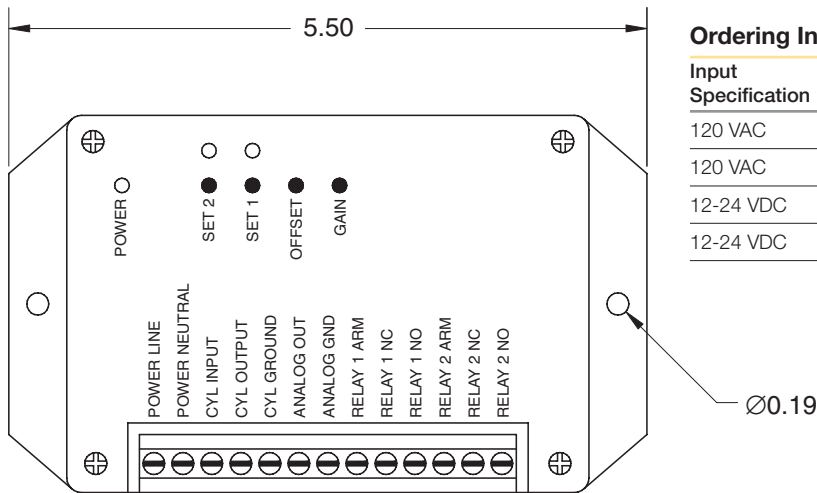

**Ordering Information**

Input Specification	Output Specification	Part Number
120 VAC	0-10 V	1493440002
120 VAC	4-20 mA	1493440003
12-24 VDC	0-10 V	1493440004
12-24 VDC	4-20mA	1493440005

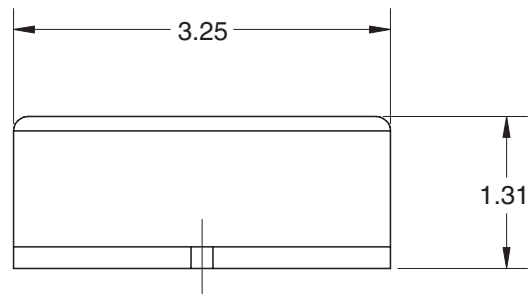
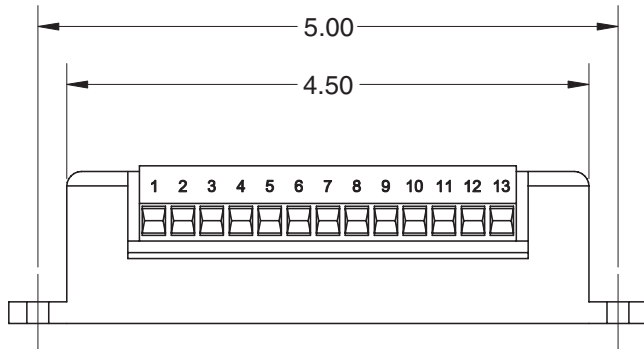

**Specifications \***

Power Input Requirements	12 to 24 VDC, 0.1 amps, or 120 VAC, 60 Hz, 0.1 amps
Output specifications – Set Point	Relay (2) 2 amps @ 24 VDC or 120 VAC
Output Specifications – Scalable	0 to 10 V, 1 mA max. output current (10K ohm impedance min.) 4 to 20mA, into 500-ohm max. impedance
Maximum Zero Offset	50% of cylinder stroke
Minimum Span Range	50% of cylinder stroke
Enclosure Dimensions	1.31" h x 5.50" w x 3.25" d
Electronics Temperature Operating Range	40°F to 160°F

\* Compatible with 6" stroke cylinder unless otherwise specified, or ordered with cylinder.

Please reference Parker Bulletin #0971-G-B2 for information regarding programming and operation of this controller.

**Round Body  
Pneumatic Cylinders**  

---

**SR/SRM/SRD/SRDM  
Series**  

---

**SRG/SRGM  
Series**  

---

**SRX  
Series**  



---

**P1A  
Series**  

---

**P  
Series**

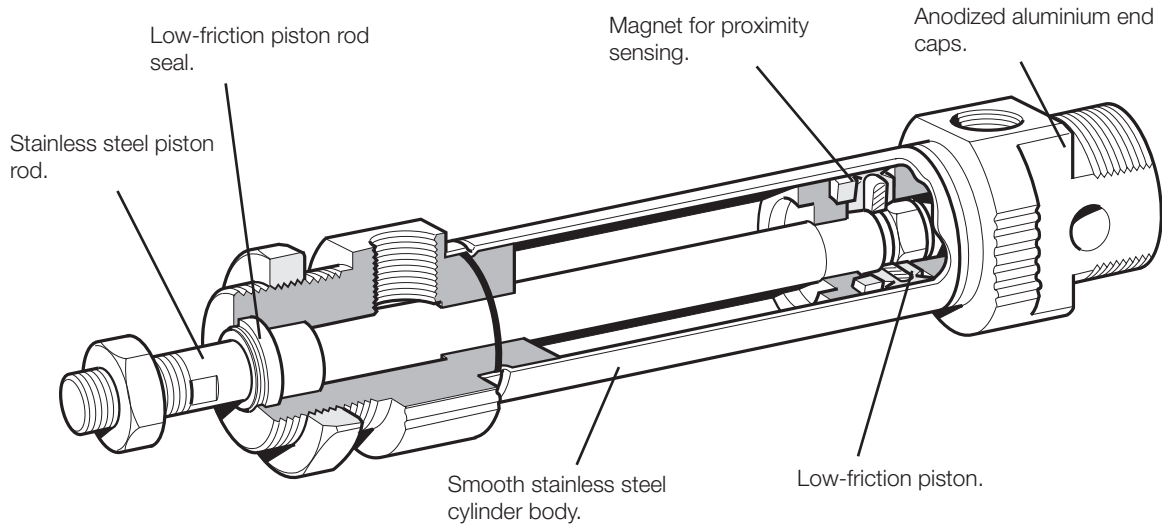
**P1A Series**



C	Round Body Pneumatic Cylinders
	SR/SRM/SRD/SRDM Series
	SRG/SRGM Series
	SRX Series
	P1A Series
	P Series

The Parker P1A series of pneumatic cylinders are intended for use in a wide range of applications. These cylinders are particularly suitable for lighter duties in the packaging, food and textile industries. Hygienic design, the use of corrosion-resistant materials and initial lubrication with our food-grade grease makes the cylinders suitable for food industry applications.

Proven design and high quality manufacturing throughout ensure long service life and optimum performance.

Mounting dimensions are in accordance with ISO 6432 and CETOP RP52P. This greatly simplifies installation and worldwide interchangeability.

The Mini ISO range is available with bumpers or adjustable pneumatic cushioning. Controlled by simple bleed screws for fine adjustment, the adjustable cushioned cylinders can be operated with higher mass loads and at higher speeds than those with fixed end cushioning bumpers.

The Mini ISO range is also available in an all-stainless version with piston rod, cylinder body and end covers of stainless steel for use in extremely severe environments. Consult the Wadsworth, Ohio facility for more information.

A complete range of sensors for proximity sensing is available as accessories: both reed and solid state sensors are available. Either can be supplied with flying leads or cable and multi-pin connector. See Electronic Sensors section for specifications and part numbers.

**Double Acting**

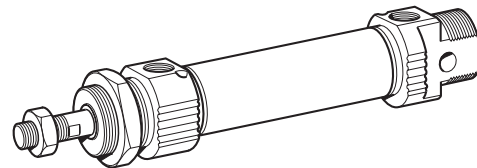

**Double Acting, Double Rod**

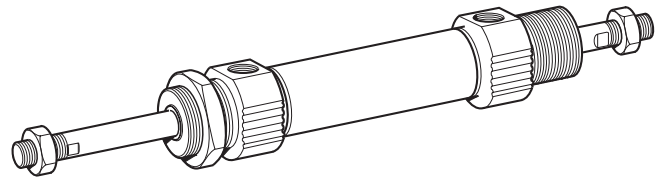

**Single-Acting, Spring Return**

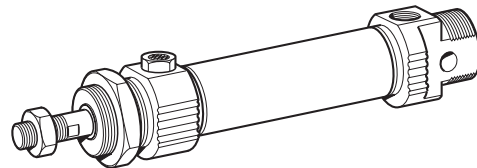

**Single-Acting, Spring Extend**

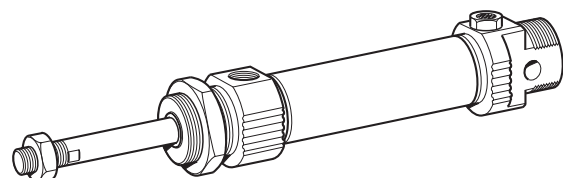

For inventory, lead times, and kit lookup, visit [www.pdnplu.com](http://www.pdnplu.com)



Features

- Conforms to ISO 6432 and CETOP RP52P standards
- 5 bore sizes, 10mm to 25mm
- Stainless steel body with black anodized aluminum end caps
- Stainless steel piston rod
- Magnetic piston and bumpers standard



Operating information

Operating pressure:	10 bar (145 PSIG)
Temperature range:	
Working	-20°C to 80°C (-4°F to 176°F)
High temperature version	
20mm, 25mm	-10°C to 150°C (14°F to 302°F)
10mm, 12mm, 16mm	-10°C to 120°C (14°F to 248°F)
Filtration requirements:	40 micron, dry filtered air

Ordering Information

**P1A - S**

Bore Size	
010	10mm
012	12mm
016	16mm
020	20mm
025	25mm

**016**

Cylinder Type / Function	
M	Double-Acting, Adjustable Cushioning, Ø16-25 mm. Not for Sealing Material Type F.
D	Double-Acting, Bumpers, Ø10 - Ø25
F	Double-Acting, Adjustable Cushioning, Double Rod, Ø16-25 mm. Not for Sealing Material Type F.
K	Double-Acting, Bumpers, Double Rod, Ø10 - Ø25
S	Single-Acting, Bumpers, Spring Return for Retract Stroke, Ø10-25 mm
T	Single-Acting, Bumpers, Spring Extend for Advance Stroke, Ø16-25 mm

**M**

**S**

Sealing Material	
S	Standard -20°C to 80°C (-4°F to 176°F) Magnetic Piston
F	High Temperature: Ø12 mm, 16 mm, 20 mm and 25 mm -10°C to 150°C. (14°F to 302°F) Non Magnetic Piston
V	External Seals of Fluorinated Rubber -20°C to +80°C (-4°F to 176°F) Magnetic Piston

**-**

**0025**

Stroke Length, mm
E.g. 0025 = 25 mm For standard stroke length and max length see table below.

Stroke Lengths		Stroke Length (* = standard, ° = non-standard, blank = N/A)															
Cylinder Model	Bore Size	10	15	20	25*	30	40	50*	80*	100*	125*	160*	200*	250*	320*	400*	500*
<b>Double Acting with Fixed End-Cushioning:</b>																	
P1A-S 010 D	10	•	•	•	•	•	•	•	•	•	•	•	•	•	•	•	•
P1A-S 012 D	12	•	•	•	•	•	•	•	•	•	•	•	•	•	•	•	•
P1A-S 016 D	16	•	•	•	•	•	•	•	•	•	•	•	•	•	•	•	•
P1A-S 020 D	20	•	•	•	•	•	•	•	•	•	•	•	•	•	•	•	•
P1A-S 025 D	25	•	•	•	•	•	•	•	•	•	•	•	•	•	•	•	•
<b>Double Acting with Adjustable End-Cushioning:</b>																	
P1A-S 016 M	16			•	•	•	•	•	•	•	•	•	•	•	•	•	•
P1A-S 020 M	20			•	•	•	•	•	•	•	•	•	•	•	•	•	•
P1A-S 025 M	25			•	•	•	•	•	•	•	•	•	•	•	•	•	•
<b>Single Acting:</b>																	
P1A-S 010 SS	10	•	•	•	•	•	•	•	•								
P1A-S 012 SS	12	•	•	•	•	•	•	•	•								
P1A-S 016 SS(TS)	16	•	•	•	•	•	•	•	•**								
P1A-S 020 SS(TS)	20	•	•	•	•	•	•	•	•								
P1A-S 025 SS(TS)	25	•	•	•	•	•	•	•	•								

\* Standard stroke lengths in mm according to ISO 4393  
\*\* Not for the TS version

**Sensors**

See section L for sensors.

C

Round Body Pneumatic Cylinders

SR/SRM/SRD/SRDM Series

SRG/SRGM Series

SRX Series

P1A Series

P Series



For inventory, lead times, and kit lookup, visit [www.pdnplu.com](http://www.pdnplu.com)

**Technical Data**

**Standard Specifications**

- Working pressure max 10 bar (145 PSI)
- Working temperature max 80°C (176°F)  
min -20°C (4°F)
- High-temperature version max 150°C (Ø20 and 25 mm) 302°F  
120°C (Ø10, 12 and 16 mm) 248°F  
min -10°C (14°F)
- Prelubricated, further lubrication is not normally necessary.
- If additional lubrication is introduced it must be continued.



**Material Specification**

Piston rod	Stainless steel, DIN X 10 CrNiS 18 9
Piston rod seal	Fluorocarbon rubber FPM
Piston rod bearing	Multilayer PTFE/steel
End covers	Anodized aluminium
O-ring, internal	Nitrile rubber, NBR
Cylinder barrel	Stainless steel, DIN X 5 CrNi 18 10
Piston, complete	Nitrile rubber, NBR/steel
Magnet holder	Thermoplastic elastomer
Magnet	Plastic-coated magnetic material
Return spring	Surface-treated steel
Cushioning screw	Stainless steel, DIN X 10 CrNiS 18 9

Cylinders are supplied complete with nose mounting and piston rod nuts.

Cylinders with double piston rods are supplied with two piston rod nuts

**Variants Mini ISO:**

**High-temperature version, type F:**

Piston rod seal	Fluorocarbon rubber, FPM
Piston complete, Ø10-Ø16	HNBR/steel
Piston complete, Ø20-Ø25	FPM/steel

**PTFE and copper free cylinders, type N:**

Piston rod bearing	PA plastic
--------------------	------------

**Cylinders with outer sealings in fluorocarbon, type V:**

Piston rod seal/ Scraper ring	Fluorocarbon rubber, FPM
----------------------------------	--------------------------

Note: Spare part = new cylinder

**Quick Reference**

Model #	Cylinder		Piston Rod			Thread	Total Weight at 0mm Stroke (lbs)	Additional Weight per 10mm Stroke (lbs)	Air Consumption	Port Size
	Bore (mm)	Area (cm²)	Dia. (mm)	Area (cm²)	Area (cm²)					
<b>Double Acting, Cushioned Stroke</b>										
P1A-S 010 D	10	0.78	4	0.13	M4	0.09	0.007	0.0004 †	M5	
P1A-S 012 D	12	1.13	6	0.28	M6	0.15	0.009	0.0005 †	M5	
P1A-S 016 D	16	2.01	6	0.28	M6	0.20	0.012	0.0009 †	M5	
P1A-S 020 D	20	3.14	8	0.50	M8	0.40	0.015	0.0010 †	G1/8	
P1A-S 025 D	25	4.91	10	0.78	M10x1.25	0.89	0.025	0.0023 †	G1/8	
<b>Double Acting, Adjustable Cushioning</b>										
P1A-S 016 M	16	2.01	6	0.28	M6	0.20	0.012	0.0009 †	M5	
P1A-S 020 M	20	3.14	8	0.50	M8	0.40	0.015	0.0010 †	G1/8	
P1A-S 025 M	25	4.91	10	0.78	M10x1.25	0.89	0.025	0.0023 †	G1/8	
<b>Single Acting</b>										
P1A-S 010 SS	10	0.78	4	0.13	M4	0.09	0.007	0.0002 †	M5	
P1A-S 012 SS	12	1.13	6	0.28	M6	0.18	0.009	0.0003 †	M5	
P1A-S 016 SS(TS)	16	2.01	6	0.28	M6	0.22	0.012	0.0005 †	M5	
P1A-S 020 SS(TS)	20	3.14	8	0.50	M8	0.40	0.015	0.0008 †	G1/8	
P1A-S 025 SS(TS)	25	4.91	10	0.78	M10x1.25	0.58	0.025	0.0013 †	G1/8	

† Free air consumption per 10 mm stroke length for a double stroke at 6 bar (87 PSI)

C  
 Round Body  
 Pneumatic Cylinders  
 SR/SRM/SRD/SRDM  
 Series  
 SRG/SRGM  
 Series  
 SRX  
 Series  
 P1A  
 Series  
 P  
 Series



For inventory, lead times, and kit lookup, visit [www.pdnplu.com](http://www.pdnplu.com)

**Cylinder Forces**

Indicated cylinder forces are theoretical and should be reduced according to the working conditions.

**Double Acting**

Model Number	Bore Size mm	Theoretical Piston Force (lbs) at 6 Bar (87 PSI)	
		Extension	Retraction
P1A-S 010 D	10	10.57	8.76
P1A-S 012 D	12	15.07	11.25
P1A-S 016 D	16	26.98	23.15
P1A-S 020 D	20	42.27	35.52
P1A-S 025 D	25	66.10	55.53
P1A-S 016 M	16	26.98	23.16
P1A-S 020 M	20	42.27	35.52
P1A-S 025 M	25	66.10	55.53

**Single Acting**

Model Number	Stroke	Theoretical Piston Force (lbs) at 6 Bar (87 PSI)			
		Spring Retraction		Spring Extension	
		lbs. Max	lbs. Min	lbs. Max	lbs. Min
P1A-S 010 SS	10	8.5	8.1	2.4	2.0
	15	8.5	8.1	2.4	2.0
	25	8.7	8.1	2.4	2.0
	40	8.5	7.6	2.9	2.0
	50	8.7	7.6	2.9	1.7
	80	8.7	7.6	2.9	1.7
P1A-S 012 SS	10	11.9	11.4	3.6	3.1
	15	11.9	11.4	3.6	3.1
	25	12.3	11.4	3.6	2.7
	40	11.9	10.8	4.2	3.3
	50	11.9	10.8	4.2	3.1
	80	12.3	10.8	4.2	2.7
P1A-S 016 SS(TS)	10	22.0 (19.1)	22.2 (18.8)	4.7 (4.2)	4.0 (4.0)
	15	23.1 (19.3)	22.2 (18.8)	4.7 (4.2)	3.8 (3.8)
	25	23.8 (19.8)	22.2 (18.8)	4.7 (4.2)	3.3 (3.3)
	40	23.8 (20.3)	21.3 (18.8)	5.6 (4.2)	3.1 (3.1)
	50	24.2 (20.4)	21.3 (18.8)	5.6 (4.2)	2.7 (2.7)
	80	24.0 (21.3)	21.3 (18.8)	5.6 (4.2)	2.9 (2.9)
P1A-S 020 SS(TS)	10	36.6 (29.6)	36.1 (29.2)	6.1 (6.3)	5.6 (5.8)
	15	36.8 (29.8)	36.1 (29.2)	6.1 (6.3)	5.4 (5.6)
	25	37.5 (30.3)	36.1 (29.2)	6.1 (6.3)	4.7 (5.1)
	40	37.3 (31.0)	35.7 (29.2)	6.5 (6.3)	4.9 (4.9)
	50	37.7 (31.4)	35.7 (29.2)	6.5 (6.3)	4.5 (4.5)
	80	38.2 (31.2)	36.1 (24.2)	6.1 (11.2)	4.0 (4.2)
P1A-S 025 SS(TS)	10	57.5 (46.1)	56.9 (45.6)	9.2 (9.9)	8.5 (9.4)
	15	58.0 (46.5)	56.9 (45.6)	9.2 (9.9)	8.1 (9.0)
	25	58.9 (47.2)	56.9 (45.6)	9.2 (9.9)	7.2 (8.3)
	40	58.7 (48.1)	56.2 (45.6)	9.9 (9.9)	7.4 (7.4)
	50	59.4 (48.8)	56.2 (45.6)	9.9 (9.9)	6.7 (6.7)
	80	59.4 (50.1)	56.4 (46.3)	9.6 (9.2)	6.7 (5.4)

**C**

Round Body  
Pneumatic Cylinders

---

SR/SRM/SRD/SRDM  
Series

---

SRG/SRGM  
Series

---

SRX  
Series

---

P1A  
Series

---

P  
Series



For inventory, lead times, and kit lookup, visit [www.pdnplu.com](http://www.pdnplu.com)

**Cushioning**

Use the diagram below to determine the necessary size of cylinder to provide the requisite cushioning performance. The maximum cushioning performance, as indicated in the diagram, is based on the following assumptions:

- Low load, i.e. low pressure drop across the piston
- Steady-state piston speed
- Correctly adjusted cushioning screw

The load is the sum of the internal and external friction, together with any gravity forces. At high relative loading it is recommended that, for a given speed, the load should be reduced by a factor of 2.5, or that, for a given mass, the speed should be reduced by a factor of 1.5. These factors apply in relation to the maximum performance as shown in the diagram.

**Fixed End-Cushioning (Bumpers)**

Speed Ft./Sec.

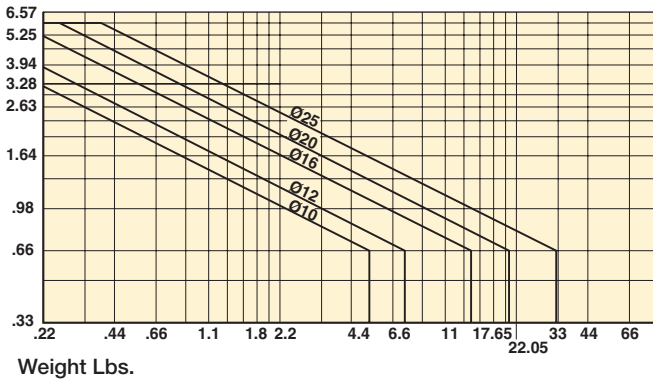

**Adjustable Pneumatic End-Cushioning**

Speed Ft./Sec.

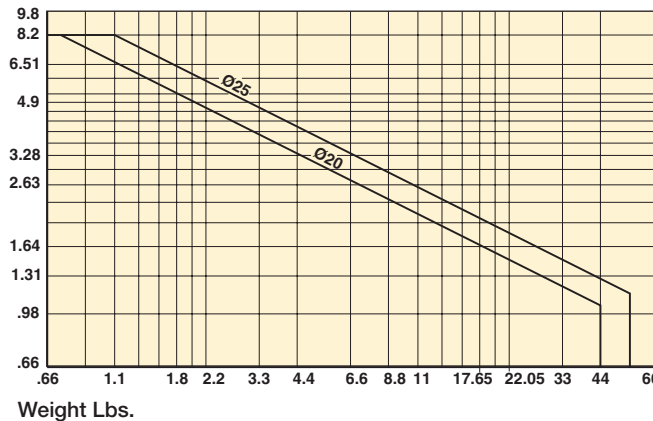

**Double-acting cushioned cylinders**

Adjustable pneumatic cushioning permits greater loads and higher operating speeds, making the cylinders suitable for more demanding applications.

These cylinders are available in bores of 16, 20 and 25 mm, with stroke lengths from 20 mm to 500 mm.

**C**  
**Round Body Pneumatic Cylinders**  
**SR/SRM/SRD/SRDM Series**  
**SRG/SRGM Series**  
**SRX Series**  
**P1A Series**  
**P Series**



For inventory, lead times, and kit lookup, visit [www.pdnplu.com](http://www.pdnplu.com)

Dimensional Data

Double acting cylinders

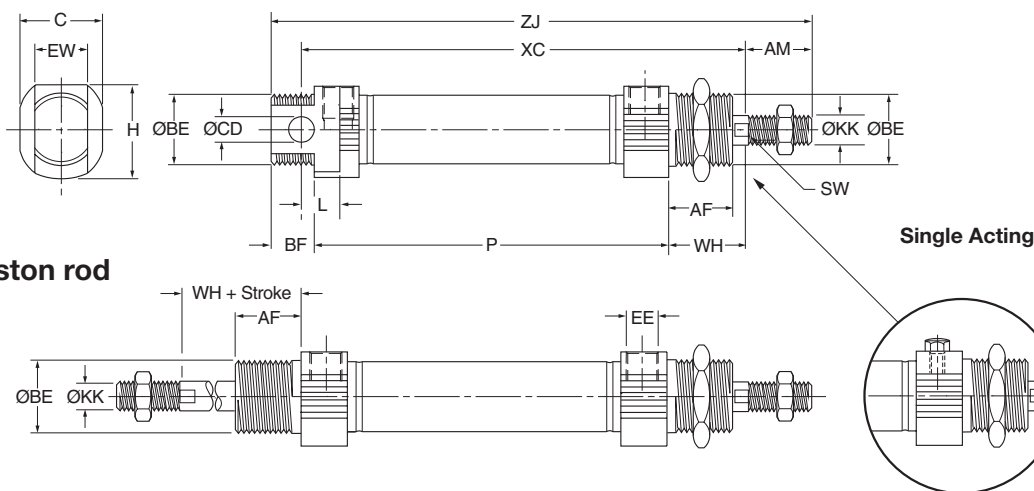

Double piston rod

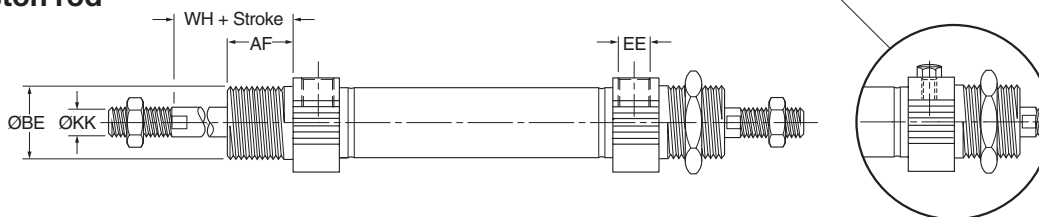

Bore Size mm	AM <sup>0/2</sup> mm	BE	AF mm	BF mm	C mm	CD <sup>h9</sup> mm	EE	EW mm	H mm	KK	L mm	SW mm	WH <sub>±1,2</sub> mm
10	12	M12x1.25	12	10	13.0	4	M5	8	13.5	M4	6	-	16
12	16	M16x1.5	18	13	17.8	6	M5	12	17.4	M6	9	5	22
16 <sup>1)</sup>	16	M16x1.5	18	13	23.8	6	M5	12	23.4	M6	9	5	22
16 <sup>2)</sup>	16	M16x1.5	18	13	17.8	6	M5	12	17.5	M6	9	5	22
20	20	M22x1.5	20	14	23.9	8	G1/8	16	23.9	M8	12	7	24
25	22	M22x1.5	22	14	26.9	8	G1/8	16	26.9	M10x1.25	12	9	28

1) P1A-S016DS/SS/TS

2) P1A-S016MS

Double acting cylinders

Bore Size mm	XC mm	ZJ mm	P mm
10	64 + stroke	84 + stroke	46 + stroke
12	75 + stroke	99 + stroke	48 + stroke
16	82 + stroke	104 + stroke	53 + stroke
20	95 + stroke	125 + stroke	67 + stroke
25	104 + stroke	132 + stroke	68 + stroke

Single-acting, spring return, type SS

Bore Size mm	XC (mm) at Various Strokes						ZJ (mm) at Various Strokes						P (mm) at Various Strokes					
	10	15	25	40	50	80	10	15	25	40	50	80	10	15	25	40	50	80
10	74	79	89	126	136	174	94	99	109	146	156	194	56	61	71	108	118	156
12	85	90	100	132	142	185	109	114	124	156	166	209	58	63	73	105	115	158
16	92	97	107	122	132	184	114	119	129	144	154	206	63	68	78	93	103	155
20	105	110	120	135	145	191	135	140	150	165	175	221	77	82	92	107	117	163
25	114	119	129	144	154	201	142	147	157	172	182	229	78	83	93	108	118	165

Single-acting, spring-extended, type TS

Bore Size mm	XC <sup>3)</sup> (mm) at Various Strokes						ZJ <sup>3)</sup> (mm) at Various Strokes						P (mm) at Various Strokes					
	10	15	25	40	50	80	10	15	25	40	50	80	10	15	25	40	50	80
16	107	112	122	137	147	-	129	134	144	159	169	-	78	83	93	108	118	-
20	120	125	135	150	160	195	150	155	165	180	190	225	92	97	107	122	132	167
25	129	134	144	159	169	205	157	162	172	187	197	233	93	98	108	123	133	169

3) With piston rod retracted, as shown in the dimension drawing  
Length tolerances ±1 mm Stroke length tolerance +1.5/0 mm



For inventory, lead times, and kit lookup, visit [www.pdnplu.com](http://www.pdnplu.com)

C55

Parker Hannifin Corporation  
Pneumatic Division  
Wadsworth, Ohio  
[www.parker.com/pneumatics](http://www.parker.com/pneumatics)

Round Body Pneumatic Cylinders  
 SR/SRM/SRD/SRDM Series  
 SRG/SRGM Series  
 SRX Series  
 P1A Series  
 P Series

**Flange - MF8**

Cylinder Ø mm	A	B	C	D	E	F	Weight lbs	Part Number
10	4.5	30	40	22	3	13	0.025	<b>P1A-4CMB</b>
12-16	5.5	40	52	30	4	18	0.055	<b>P1A-4DMB</b>
20	6.6	50	66	40	5	19	0.100	<b>P1A-4HMB</b>
25	6.6	50	66	40	5	23	0.100	<b>P1A-4HMB</b>

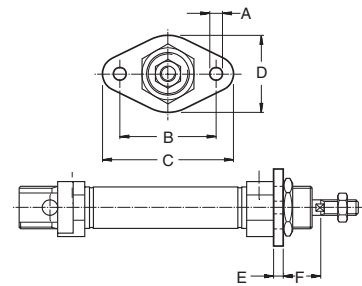
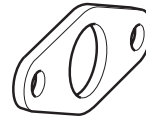

**Foot - MS3**

Cylinder Ø mm	A mm	B mm	C mm	D mm	E mm	F mm	G mm	H mm	I mm	Weight lbs	Part Number
10	4.5	16	25	35	3	24	26.0	16	11	0.045	<b>P1A-4CMF</b>
12-16	5.5	20	32	42	4	32	32.5	20	14	0.08	<b>P1A-4DMF</b>
20	6.5	25	40	54	5	36	45.0	25	17	0.18	<b>P1A-4HMF</b>
25	6.5	25	40	54	5	40	45.0	25	17	0.18	<b>P1A-4HMF</b>

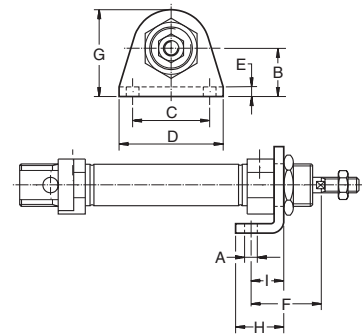
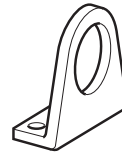

**Cover Trunnion**

Cylinder Ø mm	A mm	B h14 mm	C mm	D mm	E e9 mm	F mm	G mm	H mm	Weight lbs	Part Number
10	12.5	26	38	20	8	4	6	10	0.03	<b>P1A-4CMJ</b>
12-16	16.5	38	58	25	10	6	8	14	0.07	<b>P1A-4DMJ</b>
20	22.5	46	66	30	10	6	8	16	0.08	<b>P1A-4HMJ</b>
25	22.5	46	66	30	10	6	8	20	0.08	<b>P1A-4HMJ</b>

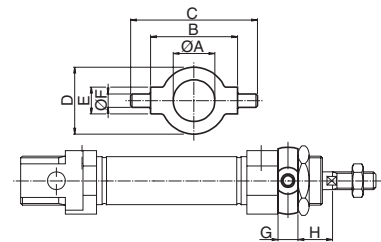
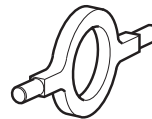

**Mounting Nut**

Cylinder Ø mm	A mm	B mm	C mm	Weight lbs	Part Number
10	19	6	M12x1.25	0.02	<b>9127385101</b>
12-16	24	8	M16x1.50	0.04	<b>9126725406</b>
20-25	32	11	M22x1.50	0.09	<b>9126725407</b>

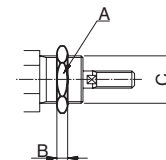

Most popular.



For inventory, lead times, and kit lookup, visit [www.pdnplu.com](http://www.pdnplu.com)

**C**  
 Round Body  
 Pneumatic Cylinders  
 SR/SRM/SRD/SRDM  
 Series  
 SRG/SRGM  
 Series  
 SRX  
 Series  
 P1A  
 Series  
 P  
 Series

**Clevis Bracket**

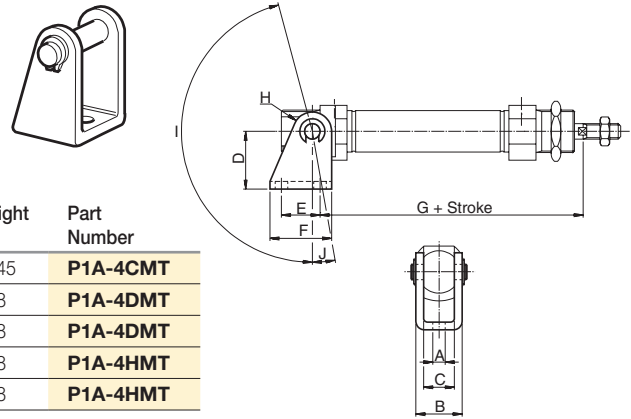

Cylinder Ø mm	A mm	B mm	C mm	D mm	E mm	F mm	G mm	H mm	I °	J °	Weight lbs	Part Number
10	4.5	13	8	24	12.5	20	65.3	5	160	17	0.045	<b>P1A-4CMT</b>
12	5.5	18	12	27	15.0	25	73.0	7	170	15	0.08	<b>P1A-4DMT</b>
16	5.5	18	12	27	15.0	25	80.0	7	170	15	0.08	<b>P1A-4DMT</b>
20	6.5	24	16	30	20.0	32	91.0	10	165	10	0.18	<b>P1A-4HMT</b>
25	6.5	24	16	30	20.0	32	100.0	10	165	10	0.18	<b>P1A-4HMT</b>

**Rod clevis**

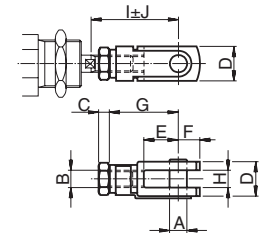
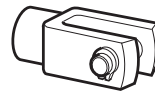

Cylinder Ø mm	A mm	B	C mm	D mm	E mm	F mm	G mm	H mm	I mm	J mm	Weight lbs	Part Number
10	4	M4	2.2	8	8	5	16	4	22.0	2.0	0.015	<b>P1A-4CRC</b>
12-16	6	M6	3.2	12	12	7	24	6	31.0	3.0	0.05	<b>P1A-4DRC</b>
20	8	M8	4.0	16	16	10	32	8	40.5	3.5	0.10	<b>P1A-4HRC</b>
25	10	M10 x 1.25	5.0	20	20	12	40	10	49.0	3.0	0.21	<b>P1A-4JRC</b>

**Swivel Rod Eye**

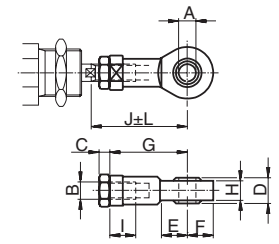

Cylinder Ø mm	A mm	B	C mm	D mm	E mm	F mm	G mm	H mm	I mm	J mm	K mm	L mm	Weight lbs	Part Number
10	5	M4	2.2	8	10	9	27	6.0	8	33.0	9	2.0	0.04	<b>P1A-4CRS</b>
12-16	6	M6	3.2	9	10	10	30	6.8	9	38.5	11	1.5	0.06	<b>P1A-4DRS</b>
20	8	M8	4.0	12	12	12	36	9.0	12	46.0	14	2.0	0.10	<b>P1A-4HRS</b>
25	10	M10 x 1.25	5.0	14	14	14	43	10.5	15	52.5	17	2.5	0.19	<b>P1A-4JRS</b>

**Rod Nut**

Stainless Steel, DIN x 5 CrNi 18 10

Cylinder Ø mm	D mm	F mm	E mm	Weight lbs	Part Number
10	M4	7	2.2	0.002	<b>9127385121</b>
12-16	M6	10	3.2	0.004	<b>9127385122</b>
20	M8	13	4.0	0.010	<b>9127385123</b>
25	M10x1.25	17	5.0	0.015	<b>9126725404</b>

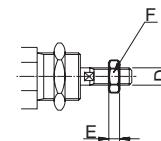

Most popular.



For inventory, lead times, and kit lookup, visit [www.pdnplu.com](http://www.pdnplu.com)



Features

P Series

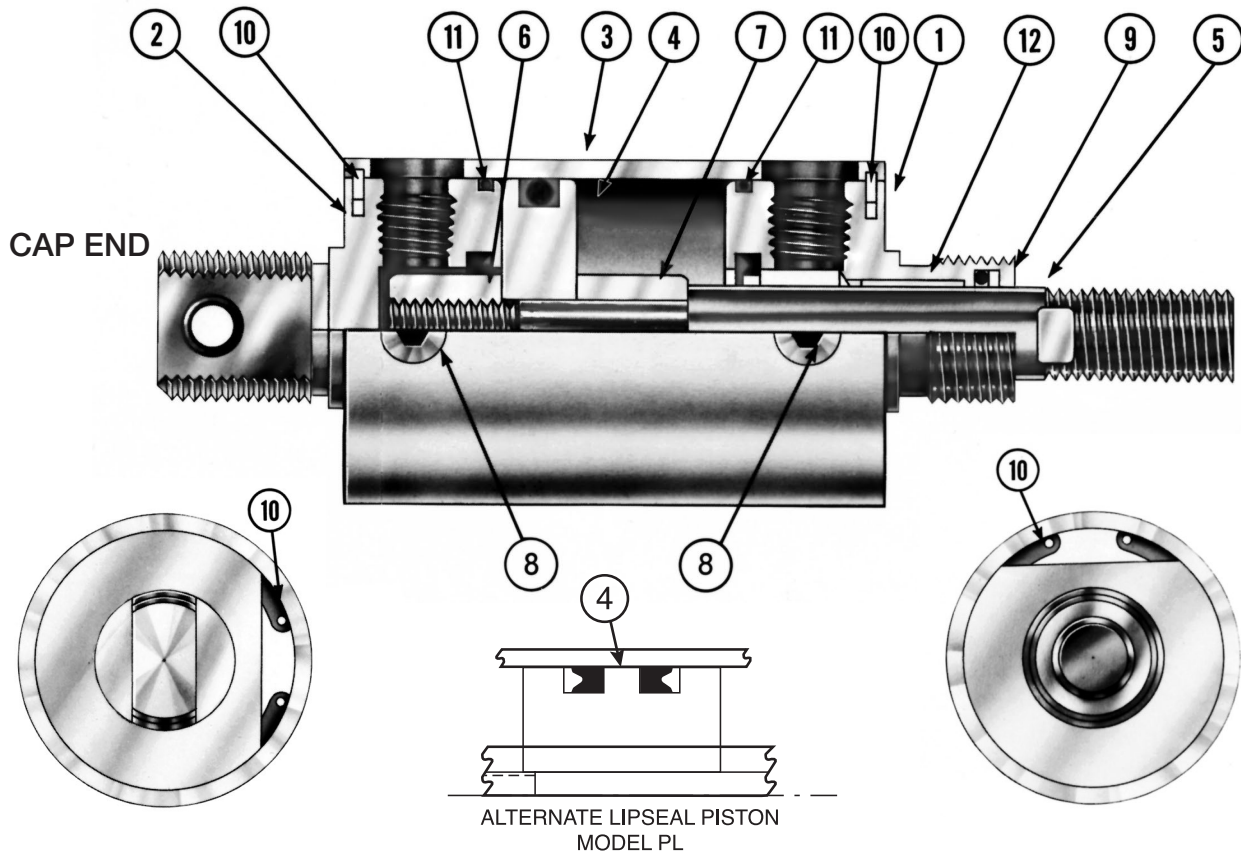

C  
Round Body  
Pneumatic Cylinders  
SR/SRM/SRD/SRDM  
Series  
SRG/SRGM  
Series  
SRX  
Series  
P1A  
Series  
P  
Series

Features

- ①② **Heads and Caps** are lightweight aluminum for maximum corrosion resistance. The cap is provided with a steel pivot bushing.
- ③ **Cylinder Body** is hard anodized aluminum for corrosion and abrasion resistance. The smooth I.D. finish provides long seal life.
- ④ **The Piston** is available with either O-Ring or Lipseal® design.
- ⑤ **Piston Rod** is chrome plated steel.\* The piston is secured to the rod with anaerobic adhesive. Full diameter threads are provided for maximum strength. Wrench flats are standard.
- ⑥⑦ **Adjustable Cushions** are available on 2" thru 4" bore sizes, while fixed cushions are available on 1-1/8" and 1-1/2" bore sizes.
- ⑧ **The Cushion Adjustment Needle** is recessed and retained for precise, safe adjustment on all adjustable cushions.
- ⑨ The wear-compensating **Rod Seal** design conforms to pressure variations and provides maximum seal life.
- ⑩ **High Strength Steel Retaining Snap Ring** (210,000 PSI ultimate) is precision made to securely lock the head and cap in place. Easily removed for quick disassembly.
- ⑪ **O-Ring Static Tube Seal** is standard for positive no-leak sealing.
- ⑫ **Rod Bearing** is low friction bronze for high performance and longer wear.

\* 1-1/8" bore has standard 416 stainless steel piston rod material.



For inventory, lead times, and kit lookup, visit [www.pdnplu.com](http://www.pdnplu.com)

## Features

- Repairable design, aluminum construction
- 6 bore sizes: 1-1/8" to 4"
- Double-acting, spring-return and spring-extend models
- Cushions optional at either or both ends
- Universal nose and tang mounts
- Standard stroke lengths to 20 inches in one inch increments, plus 1-1/2", 2-1/2" and 3-1/2" strokes. Fraction strokes and strokes over 20 inches are available upon request.



## Operating information

Operating pressure:	150 PSIG (8 bar)
Temperature range:	
Standard seals	-10°F to 165°F (-23°C to 74°C)
Fluorocarbon seals	-10°F to 250°F (-23°C to 121°C)
Filtration requirements:	40 micron, dry filtered air

## Ordering information

2-1/2"	K	P	L	U	1	6	A	C	6"
<b>Bore Size</b> 1-1/8" 1-1/2" 2" 2-1/2" 3" 4"		<b>Series</b>	<b>Piston</b> Blank O-Ring Piston L Lipseal Piston <small>Sensors available on lipseal pistons only.</small>						<b>Stroke</b> Specify in inches.
<b>Cushion Head End</b> Blank No Cushion C Cushion Head End			<b>Ports</b> U N.P.T.F.			<b>Rod End Threads</b> A Inch		<b>Cushion Cap End</b> Blank No Cushion C Cushion Cap End	
<b>Double Rod</b> Blank Single Rod K Double Rod			<b>Seals / Options</b> Blank Buna-N V Fluorocarbon M Magnet with Buna-N Seals <sup>1</sup>				<b>Rod Material</b> Blank Standard Rod D 416 Stainless Steel <sup>2</sup>		
<b>Mounting Style</b> Blank Standard N No Tang A Dual Tang			<b>Spring</b> E Spring Extend R Spring Return			<b>Rod Thread</b> 6 Standard 3 Special <small>(For special rod end specify "CC" thread Dia. A and LE or LE1 or Dim. or submit sketch.)</small>			
			<b>Special Number</b> Use "S" symbol only if special feature is required (specify). NOTE: Do not use symbol "S" for rod end modification.			<b>Rod Diameter Style</b> 1 Standard <small>For double rod cylinders specify rod code twice.</small>			
<p><b>Safety Cushion Adjustment Location</b></p> <p>With port in position 1, cushion location will be position 4.</p>									
<p><b>Notes:</b></p> <p><sup>1</sup> Must specify lipseal piston with magnet option.  <sup>2</sup> Standard on 1-1/8" bore. {D} not required.</p>									
								<p><b>Sensors</b> See section L for sensors.</p>	

For ordering purposes, when special options or common modifications are requested, the factory will assign a sequential part number in place of the model number.



For inventory, lead times, and kit lookup, visit [www.pdnplu.com](http://www.pdnplu.com)

- Nominal pressure – up to 150 PSI air
- Repairable design
- Bore sizes: 1-1/8", 1-1/2", 2", 2-1/2", 3" and 4"
- Double-acting, Spring-return and Spring-extend models
- Cushions optional at either or both ends
- Universal nose and tang mounts
- Factory pre-lubricated
- Standard temperature range: -10°F to 165°F fluorocarbon seals for operation up to 250°F are available at extra cost.
- Standard stroke lengths to 20 inches in one inch increments, plus 1-1/2", 2-1/2" and 3-1/2" strokes. Fraction strokes and strokes over 20 inches are available upon request.

**⚠ DANGER**

The piston to rod threaded connection is secured with an anaerobic adhesive which is temperature sensitive. Operating cylinders in excess of the following recommendations can cause the piston and piston rod assembly to unthread. Cylinders ordered with standard seals (Buna-N) are assembled with an anaerobic adhesive with a maximum operating temperature rating of 165°F. Cylinders ordered with Fluorocarbon seals are assembled with an anaerobic adhesive with a maximum operating temperature rating of 250°F.

Cylinders originally manufactured with standard seals (Buna-N) that will be exposed to an ambient temperature above 165°F must be modified for higher temperature service. Contact your local factory immediately and arrange for the piston to piston rod connection to be properly modified for the higher temperature service.

**Mounting Styles Available**

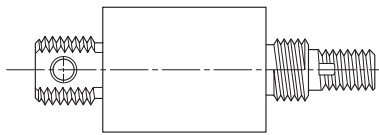

**Model P** – O-Ring Piston – Single Rod  
1-1/8" Bore thru 3" Bore

**Model PL** – Lipseal Piston – Single Rod  
1-1/8" Bore thru 4" Bore

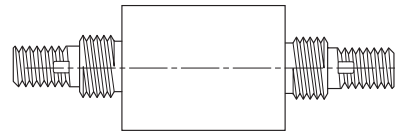

**Model KP** – O-Ring Piston – Double Rod  
1-1/8" Bore thru 3" Bore

**Model KPL** – Lipseal Piston – Double Rod  
1-1/8" Bore thru 4" Bore

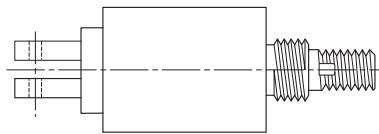

**Model AP** – O-Ring Piston – Single Rod  
1-1/8" Bore thru 3" Bore

**Model APL** – Lipseal Piston – Single Rod  
1-1/8" Bore thru 4" Bore

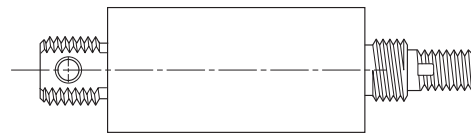

**Model PR** – O-Ring Piston – Spring Return

**Model PE** – O-Ring Piston – Spring Extend  
1-1/8" Bore thru 3" Bore

**Model PLR** – Lipseal Piston – Spring Return

**Model PLE** – Lipseal Piston – Spring Extend  
1-1/8" Bore thru 4" Bore

**Force Data**

(to determine force multiply operating pressure by area figures below)

Bore Size	Rod Dia.	Major Area (sq. in.)	Minor Area (sq. in.)
1-1/8"	3/8"	0.992	0.882
1-1/2"	1/2"	1.766	1.570
2"	5/8"	3.141	2.835
2-1/2"	3/4"	4.906	4.464
3"	3/4"	7.065	6.623
4"	1"	12.560	11.775

**Cylinder Cushion Lengths**

Bore	Head	Cap
1-1/8"	0.560"	0.560"
1-1/2" & 2"	0.750"	0.750"
2-1/2" & 3"	0.875"	0.875"
4"	1.250"	1.250"

**C**  
**Round Body Pneumatic Cylinders**  
**SR/SRM/SRD/SRDM Series**  
**SRG/SRGM Series**  
**SRX Series**  
**P1A Series**  
**P Series**



For inventory, lead times, and kit lookup, visit [www.pdnplu.com](http://www.pdnplu.com)

**Model P**

O-ring piston – single rod

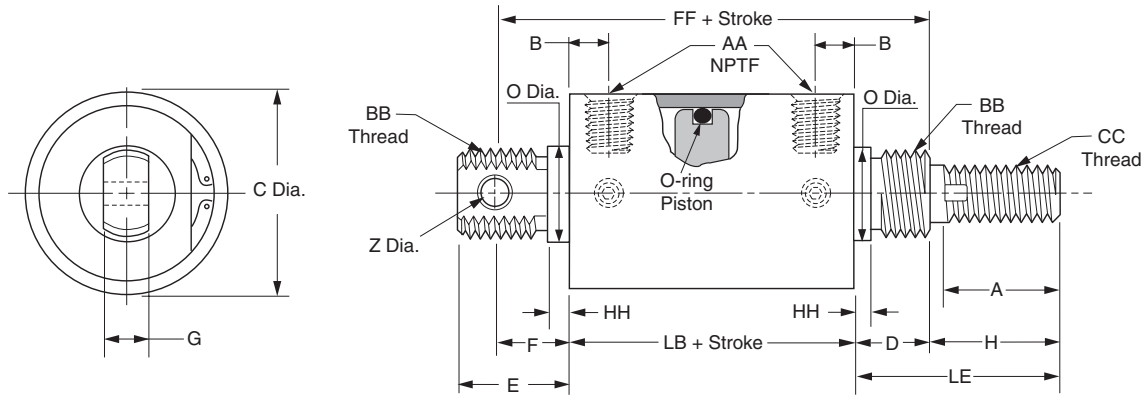

Model P cylinders are available without tang covered by dimension E minus HH at no extra charge. To order specify Model NP.

**Model KP**

O-ring piston – double rod

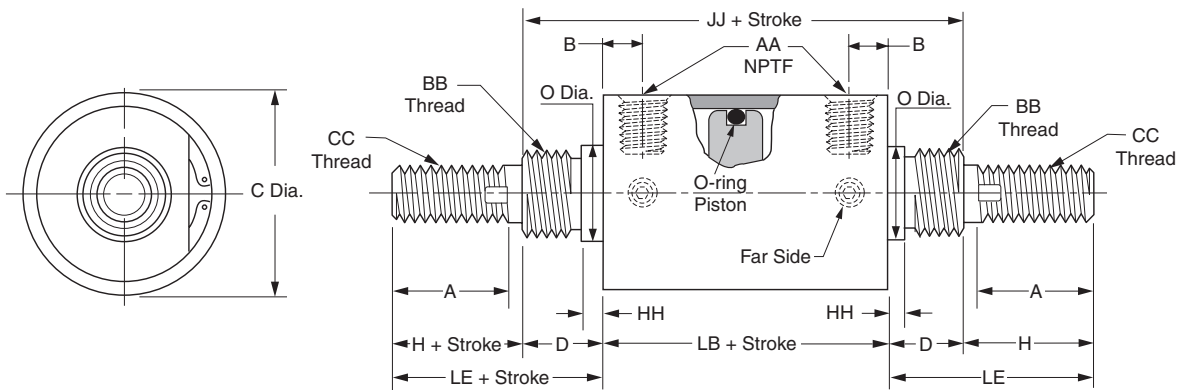

Mounting nuts not supplied with cylinder.

**Model P and KP single and double rod cylinders**

Bore Size	Rod Dia.	LB	B	C	D	E	F	G	H	A	O	Z	AA	BB	CC	FF	HH	JJ	LE
1-1/8	3/8	2-1/16	13/32	1-3/8	5/8	1	11/16	3/8	1	7/8	3/4	1/4	1/8	3/4-16	3/8-16	3-3/8	3/32	3-5/16	1-5/8
1-1/2	1/2	2-5/8	1/2	1-3/4	7/8	1-1/4	7/8	1/2	1-7/16	1-1/4	1-1/16	5/16	1/4	1-14	1/2-13	4-3/8	1/8	4-3/8	2-5/16
2	5/8	2-5/8	1/2	2-1/4	7/8	1-1/4	7/8	1/2	1-7/16	1-1/4	1-1/16	5/16	1/4	1-14	5/8-11	4-3/8	1/8	4-3/8	2-5/16
2-1/2	3/4	3	5/8	2-3/4	1	2	1-3/8	5/8	1-11/16	1-1/2	1-3/8	7/16	3/8	1-3/8-12	3/4-10	5-3/8	3/16	5	2-11/16
3	3/4	3	5/8	3-1/4	1	2	1-3/8	5/8	1-11/16	1-1/2	1-3/8	7/16	3/8	1-3/8-12	3/4-10	5-3/8	3/16	5	2-11/16

Note: 4" bore size offered only with Lipseal Piston.  
 FLUOROCARBON SEALS for operation to 250°F are available at extra cost. Specify model PV or KP.V.



For inventory, lead times, and kit lookup, visit [www.pdnplu.com](http://www.pdnplu.com)

**C**  
 Round Body  
 Pneumatic Cylinders  
 SR/SRM/SRD/SRDM  
 Series  
 SRG/SRGM  
 Series  
 SRX  
 Series  
 P1A  
 Series  
 P  
 Series

**Model PL**

Lipseal piston – single rod

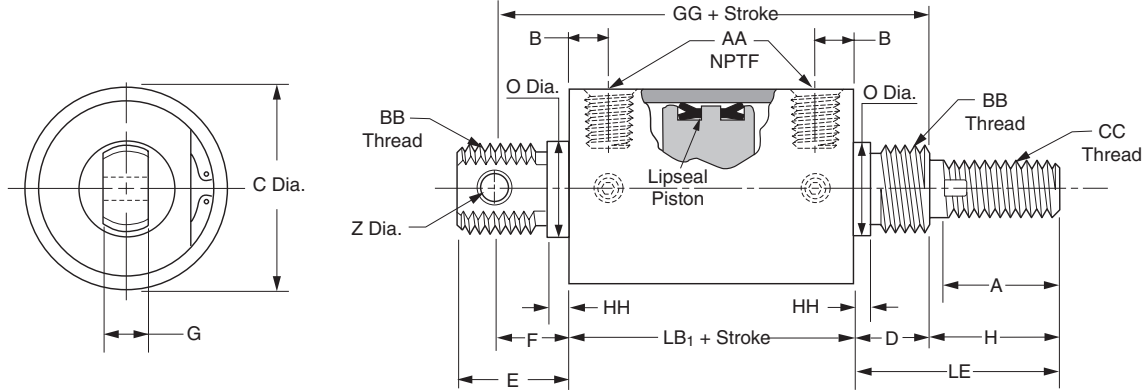

Model PL cylinders are available without tang covered by dimension E minus HH at no extra charge. To order specify Model NPL.

**Model KPL**

Lipseal piston – double rod

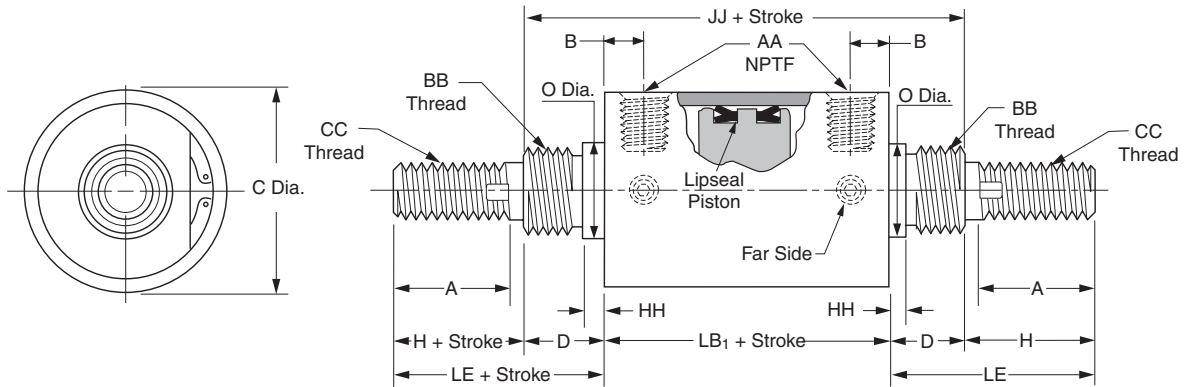

Mounting nuts not supplied with cylinder.

**Model PL and KPL single and double rod cylinders**

Bore Size	Rod Dia.	LB <sub>1</sub>	B	C	D	E	F	G	H	A	O	Z	AA	BB	CC	GG	HH	KK	LE
1-1/8	3/8	3-1/16	13/32	1-3/8	5/8	1	11/16	3/8	1	7/8	3/4	1/4	1/8	3/4-16	3/8-16	4-3/8	3/32	4-5/16	1-5/8
1-1/2	1/2	3-5/8	1/2	1-3/4	7/8	1-1/4	7/8	1/2	1-7/16	1-1/4	1-1/16	5/16	1/4	1-14	1/2-13	5-3/8	1/8	5-3/8	2-5/16
2	5/8	3-5/8	1/2	2-1/4	7/8	1-1/4	7/8	1/2	1-7/16	1-1/4	1-1/16	5/16	1/4	1-14	5/8-11	5-3/8	1/8	4-3/8	2-5/16
2-1/2	3/4	4	5/8	2-3/4	1	2	1-3/8	5/8	1-11/16	1-1/2	1-3/8	7/16	3/8	1-3/8-12	3/4-10	6-3/8	3/16	6	2-11/16
3	3/4	4	5/8	3-1/4	1	2	1-3/8	5/8	1-11/16	1-1/2	1-3/8	7/16	3/8	1-3/8-12	3/4-10	6-3/8	3/16	6	2-11/16
4	1	5-1/2	15/16	4-3/8	1-1/8	2-3/16	1-7/16	3/4	2-1/4	1-7/8	1-3/4	1/2	1/2	1-3/4-12	1-14	8-1/16	3/16	7-1/4	3-3/8

FLUOROCARBON SEALS for operation to 250°F are available at extra cost. Specify model PLV or KPLV.

**C**  
 Round Body Pneumatic Cylinders  
 SR/SRM/SRD/SRDM Series  
 SRG/SRGM Series  
 SRX Series  
 P1A Series  
 P Series



For inventory, lead times, and kit lookup, visit [www.pdnplu.com](http://www.pdnplu.com)

**Model AP**

O-ring piston – single rod  
1-1/8" bore thru 3" bore

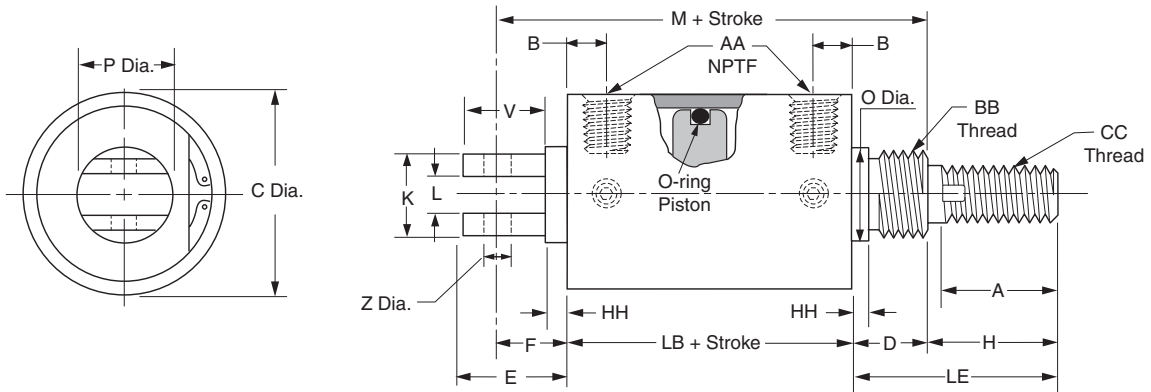

**Model APL**

Lipseal piston – single rod  
1-1/8" bore thru 4" bore

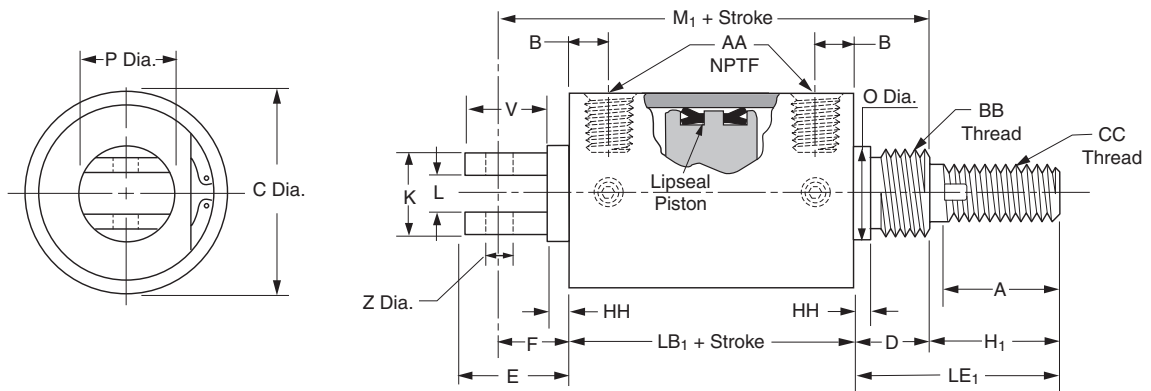

Mounting nuts not supplied with cylinder.

**Models AP and APL only**

Bore Size	Rod Dia.	LB	LB <sub>1</sub>	B	C	D	E	F	H	H <sub>1</sub>	A	K	L	M	M <sub>1</sub>	O	P	V	Z	AA	BB	CC	HH	LE	LE <sub>1</sub>
1-1/8	3/8	2-1/16	3-1/16	13/32	1-3/8	5/8	1	11/16	1	1	7/8	15/16	3/8	4-3/8	5-3/8	3/4	15/16	7/8	3/8	1/8	3/4-16	3/8-16	3/32	1-5/8	1-5/8
1-1/2	1/2	2-5/8	3-5/8	1/2	1-3/4	7/8	1-5/8	15/16	2-7/16	1-7/16	1-1/4	1-1/4	1/2	6-7/8	6-7/8	1-1/16	1-1/4	1-1/2	3/8	1/4	1-14	1/2-13	1/8	3-5/16	2-5/16
2	5/8	2-5/8	3-5/8	1/2	2-1/4	7/8	2-1/4	1-9/16	2-7/16	1-7/16	1-1/4	1-1/2	1/2	7-1/2	7-1/2	1-1/16	1-11/16	1-3/4	1/2	1/4	1-14	5/8-11	1/8	3-5/16	2-5/16
2-1/2	3/4	3	4	5/8	2-3/4	1	2-1/4	1-13/16	2-11/16	1-1/2	1-1/2	1/2	8-13/16	8-13/16	1-3/8	2-1/4	1-11/16	1/2	3/8	1-3/8-12	3/4-10	3/16	4-11/16	3-11/16	
3	3/4	3	4	5/8	3-1/4	1	2-5/8	1-5/8	3-11/16	2-11/16	1-1/2	1-1/2	1/2	9-5/16	9-5/16	1-3/8	2-1/4	1-3/4	1/2	3/8	1-3/8-12	3/4-10	3/16	4-11/16	3-11/16
4	1	-	5-1/2	15/16	4-3/8	1-1/8	2-7/8	1-7/8	-	2-1/4	1-7/8	2-1/4	3/4	-	10-3/4	1-3/4	3	2-1/2	3/4	1/2	1-3/4-12	1-14	3/16	-	3-3/8

FLUOROCARBON Seals for operation to 250°F are available at extra cost. Specify model ASPV or ASPLV.

**C**  
Round Body  
Pneumatic Cylinders

SR/SRM/SRD/SRDM  
Series

SRG/SRGM  
Series

SRX  
Series

P1A  
Series

P  
Series



For inventory, lead times, and kit lookup, visit [www.pdnplu.com](http://www.pdnplu.com)

C63

**Parker Hannifin Corporation**  
Pneumatic Division  
Wadsworth, Ohio  
[www.parker.com/pneumatics](http://www.parker.com/pneumatics)

**Model PR – Spring return**  
**Model PE – Spring extend**

O-ring piston

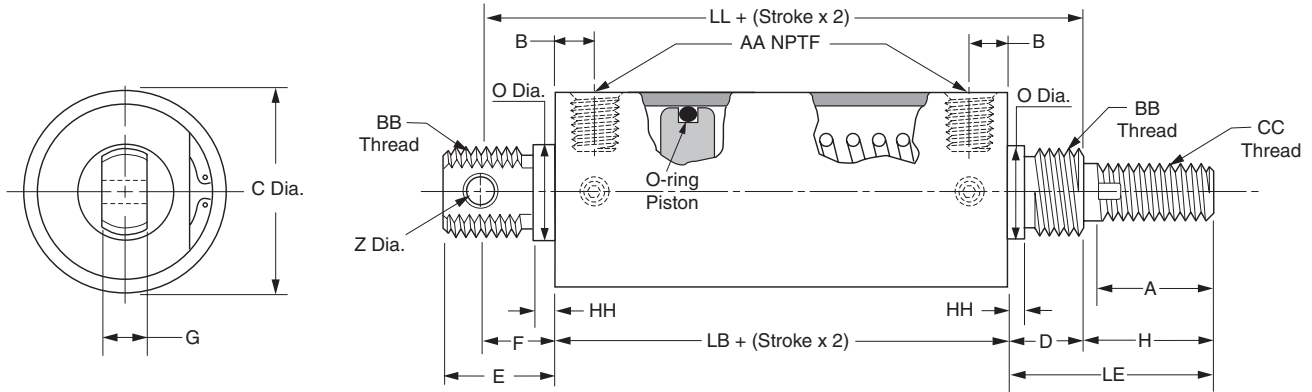

Spring return cylinders are available without tail section covered by dimension E minus HH at no extra charge. To order, add letter "N" to model number.

**Model PLR – Spring return**  
**Model PLE – Spring extend**

Lipseal piston

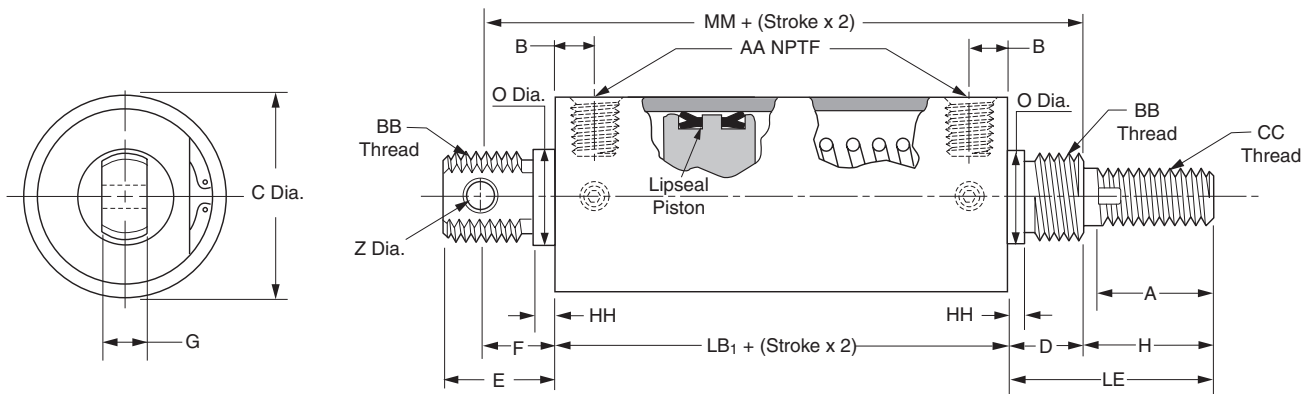

Mounting nuts not supplied with cylinder.

**For single rod spring return cylinders up to 6" stroke (no load spring)**

Bore Size	Rod Dia.	LB	LB <sub>1</sub>	B	C	D	E	F	G	H	A	O	Z	AA	BB	CC	HH	LL	MM	LE	Spring Force	
																					Pre-Load (lbs.)	Max. Load (lbs.)
1-1/8	3/8	2-1/16	3-1/16	13/32	1-3/8	5/8	1	11/16	3/8	1	7/8	3/4	1/4	1/8	3/4-16	3/8-16	3/32	3-3/8	4-3/8	1-5/8	12	36
1-1/2	1/2	2-5/8	3-5/8	1/2	1-3/4	7/8	1-1/4	7/8	1/2	1-7/16	1-1/4	1-1/16	5/16	1/4	1-14	1/2-13	1/8	4-3/8	5-3/8	2-5/16	14	45
2	5/8	2-5/8	3-5/8	1/2	2-1/4	7-8	1-1/4	7/8	1/2	1-7/16	1-1/4	1-1/16	5/16	1/4	1-14	5/8-11	1/8	4-3/8	5-3/8	2-5/16	18	48
2-1/2	3/4	3	4	5/8	2-3/4	1	2	1-3/8	5/8	1-11/16	1-1/2	1-3/8	7/16	3/8	1-3/8-12	3/4-10	3/16	5-3/8	6-3/8	2-11/16	30	64
3	3/4	3	4	5/8	3 1/4	1	2	1-3/8	5/8	1-11/16	1-1/2	1-3/8	7/16	3/8	1-3/8-12	3/4-10	3/16	5-3/8	6-3/8	2-11/16	30	64
4	1	▲	5-1/2	15/16	4-3/8	1-1/8	2-3/16	1-7/16	3/4	2-1/4	1-7/8	1-3/4	1/2	1/2	1-3/4-12	1-14	3/16	▲	8-1/16	3-3/8	50	148

▲ 4" bore spring return cylinders, available only with lipseal type piston.

\*\* Net stroke plus stop tube = gross stroke.

FLUOROCARBON SEALS for operation to 250°F are available at extra cost. Specify model PVR, PVE, PLVR or PLVE.

\* Dimensions shown are for cylinder with no load spring. For heavier springs or double rod spring return cylinders, consult factory.



For inventory, lead times, and kit lookup, visit [www.pdnplu.com](http://www.pdnplu.com)



Foot and Flange Mounts

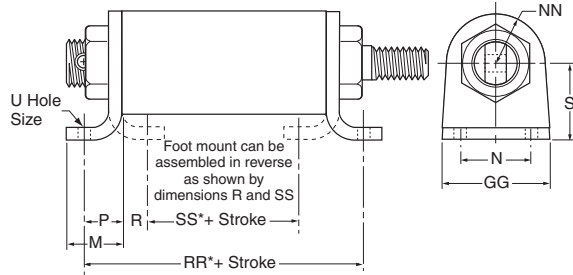

No tang type shown.  
When specified this modification is available on all P series cylinders

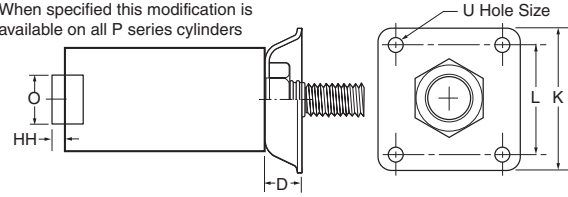

Bore Size	D	K	L	M	N	O	P	R	S	U	GG	HH	NN	RR	SS	Foot Mount*	Flange Mount**
1-1/8	5/8	2-1/2	2	1-3/8	1-11/16	3/4	7/8	5/8	1-9/32	9/32	2-11/16	3/32	11/16	3-13/16	13/16	L069190000	L069230000
1-1/2	7/8	3-1/4	2-1/2	1-9/32	1-5/8	1-1/16	7/8	9/16	1-3/4	9/32	2-7/16	1/8	1-1/8	4-3/8	1-1/2	L069200000	L069240000
2	7/8	3-1/4	2-1/2	1-9/32	1-5/8	1-1/16	7/8	9/16	1-3/4	9/32	2-7/16	1/8	1-1/8	4-3/8	1-1/2	L069200000	L069240000
2-1/2	1	4-1/2	3-3/8	1-29/32	2-1/4	1-3/8	1-1/4	7/8	2-3/8	13/32	3-9/16	3/16	1-5/8	5-1/2	1-1/4	L069210000	L069250000
3	1	4-1/2	3-3/8	1-29/32	2-1/4	1-3/8	1-1/4	7/8	2-3/8	13/32	3-9/16	3/16	1-5/8	5-1/2	1-1/4	L069210000	L069250000
4	1-1/8	5-1/4	4	2-17/32	3-1/4	1-3/4	1-3/4	1-5/16	3-3/16	15/32	4-13/16	3/16	2-3/16	9▲	2-7/8▲	L069220000	L069260000

▲ Dimension shown is for lipseal piston type.  
\* Part number includes one foot mounting and one mounting nut.  
\*\* Includes mounting nut.

Clevis Bracket

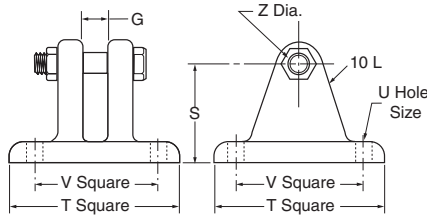

Bore Size	G	S	T	U	V	Z	Part Number
1-1/8	3/8	1-9/32	2-1/4	9/32	1-3/4	1/4	L067300000
1-1/2	1/2	1-3/4	3	9/32	2-1/4	5/16	L067310000
2	1/2	1-3/4	3	9/32	2-1/4	5/16	L067310000
2-1/2	5/8	2-3/8	4	13/32	3	7/16	L067320000
3	5/8	2-3/8	4	13/32	3	7/16	L067320000
4	3/4	3-3/16	5	15/32	3-3/4	1/2	L067330000

Connecting pin and locknut furnished with clevis bracket.

Rod Clevis

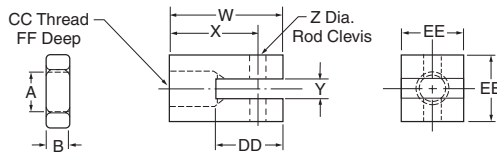

Cyl. Bore	Rod Dia.	A	B	CC	DD	EE	FF	W	X	Y	Z	Part Number
1-1/8	3/8	3/8-16	7/32	3/8-16	1-1/8	3/4	5/8	1-3/4	1-3/8	5/16	1/4	L067340000
1-1/2	1/2	1/2-13	5/16	1/2-13	1-5/16	1	15/16	2-1/4	1-3/4	3/8	5/16	L067350000
2	5/8	5/8-11	3/8	5/8-11	1-5/16	1	15/16	2-1/4	1-3/4	3/8	5/16	L067360000
2-1/2	3/4	3/4-10	27/64	3/4-10	1-5/16	1-1/4	1-1/16	2-3/8	1-13/16	1/2	7/16	L067370000
3	3/4	3/4-10	27/64	3/4-10	1-5/16	1-1/4	1-1/16	2-3/8	1-13/16	1/2	7/16	L067370000
4	1	1-14	35/64	1-14	1-13/16	1-1/2	1-9/16	3-3/8	2-5/8	5/8	1/2	L067380000

Note: Rod end jam nut furnished with rod clevis.

Most popular.

Mounting Nut for Cylinders\*\*

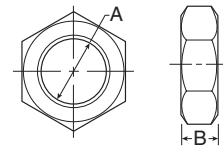

Bore Size	A	B	Part Number
1-1/8	3/4-16	27/64	0833010048
1-1/2 & 2	1-14	35/64	0849881100
2-1/2 & 3	1-3/8-12	25/32	0833010124
4	1-3/4-12	15/16	0831830000

Sensors

See section L for sensors.



For inventory, lead times, and kit lookup, visit [www.pdnplu.com](http://www.pdnplu.com)

Sensors Mounting Data / Service Kits

Sensors

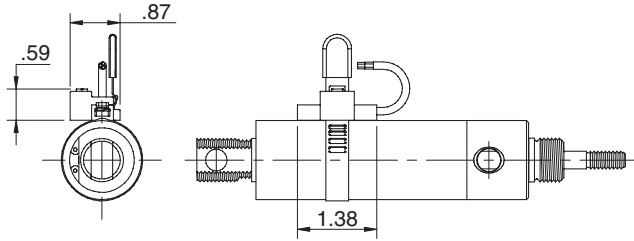

Example:

To order a 1-1/2" x 6" cylinder with P Series sensors to sense the end of stroke at both head and cap end.

Item	Qty.	Description
A	(2)	P8SAGPCHX Sensor
B	(2)	P8S-TMC02 Clamp Assembly

How To Order P Series Sensors

P Series sensors are not mounted to the cylinder prior to shipment. When ordering a cylinder to accommodate a P Series sensor:

1. Derive a proper cylinder number as shown on the Ordering Information page and include magnet, option "M" in Seals/Option Code.
2. As a separate item specify the number of sensors required.\*
3. As a third item specify the quantity of the proper clamp assembly.\*

\* For information regarding sensors, please refer to the Electronic Sensors section.

Bore	Piston Travel at Mid Stroke* (Sensor Activated)
1-1/8"	0.33
1-1/2"	0.37
2"	0.49
2-1/2"	0.44
3"	0.40
4"	0.33

\* Sensing distance at "End of Stroke" can be adjusted from 'mid-stroke' sensing distance to zero. For sensor specifications and part numbers, see Electronic Sensors section.

† Piston travel ±.01".

Service Kits

Table A

Seal kit for series "P" cylinders with o-ring piston

Contains: 2 each symbol #15 & 1 each symbol #16, 24 & 25

Bore Size	Standard Seal Kit Part Number	Hi-Temp Seal Kit Part Number
1-1/8"	L067680000	L067730000
1-1/2"	L067690000	L067740000
2"	L067700000	L067750000
2-1/2"	L067710000	L067760000
3"	L067720000	L067770000

Table B

Seal kit for series "P" cylinders with lipseal piston

Contains: 2 each symbol #15 & 23 & 1 each symbol #24 & 25

Bore Size	Standard Seal Kit Part Number	Hi-Temp Seal Kit Part Number
1-1/8"	L067780000	L067840000
1-1/2"	L067790000	L067850000
2"	L067800000	L067860000
2-1/2"	L067810000	L067870000
3"	L067820000	L067880000
4"	L067830000	L067890000

Table C

Cushion seal kit for series "P" cylinders

Contains: 2 each symbol #19 & 21 (Symbol #21 not required or supplied for 1-1/8" & 1-1/2" bore size cylinders)

Bore Size	Standard Seal Kit Part Number	Hi-Temp Seal Kit Part Number
1-1/8"	L067900000	L067950000
1-1/2"	L067910000	L067960000
2"	L067920000	L067970000
2-1/2"	L067930000	L067980000
3"	L067930000	L067980000
4"	L067940000	L067990000

**C**  
 Round Body  
 Pneumatic Cylinders  
 SR/SRM/SRD/SRDM  
 Series  
 SRG/SRGM  
 Series  
 SRX  
 Series  
 P1A  
 Series  
 P  
 Series



For inventory, lead times, and kit lookup, visit [www.pdnplu.com](http://www.pdnplu.com)

**Parts Identification**

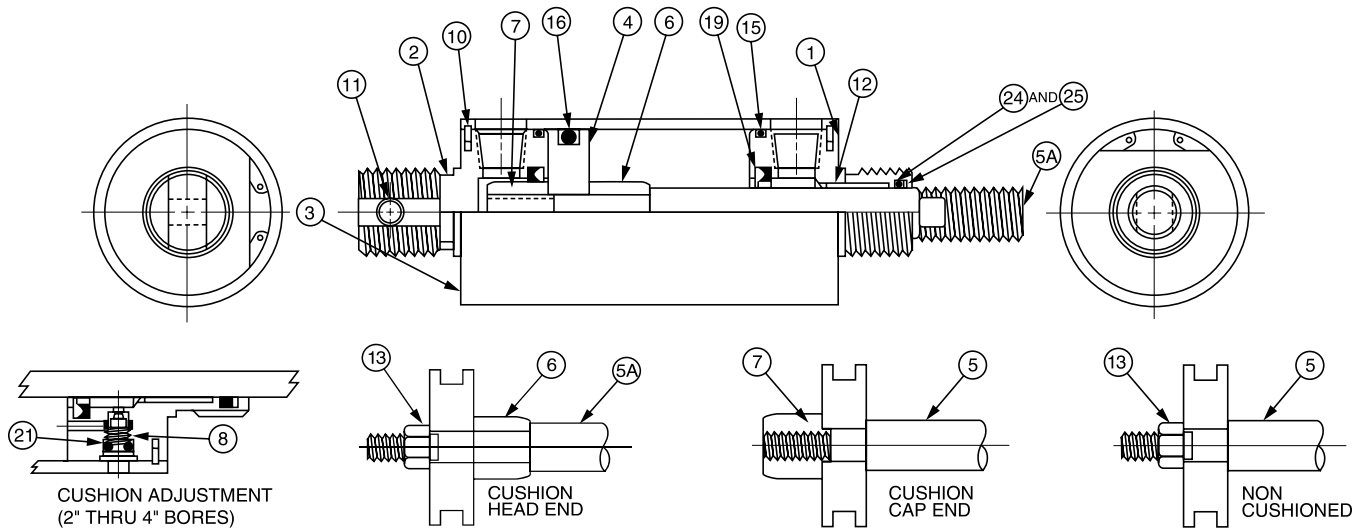

Symbol	Description
1	Head
2	Cap
3	Cylinder Body
4	Piston - O-Ring Style
4A	Piston - Lipseal Style
5	Rod - Cap Cushioned Or Non-Cushioned
5A	Rod - Head Cushioned Or Cushioned Both Ends
6	Cushion Sleeve
7	Cushion Spear
8	Cushion Needle
10	Retaining Ring
11	Pivot Bushing (Included In #2 Cap) Not Sold Separately
12	Rod Bushing (Included In #1 Head) Not Sold Separately
13	Nut - Piston
15	O-Ring - End Seal
16	O-Ring - Piston Seal
19	Lipseal - Cushion
21	O-Ring - Needle Valve
23	Lipseal - Piston Seals
24	O-Ring - Rod Seal
25	Back Up Washer - Rod Seal

**Lipseal Piston**

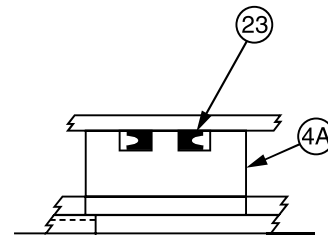

C	Round Body Pneumatic Cylinders
	SR/SRM/SRD/SRDM Series
	SRG/SRGM Series
	SRX Series
	P1A Series
	P Series

Round Body Pneumatic Cylinders
SR/SRM/SRD/SRDM Series
SRG/SRGM Series
SRX Series
P1A Series
P Series



For inventory, lead times, and kit lookup, visit [www.pdnplu.com](http://www.pdnplu.com)

**Compact Design  
Pneumatic Cylinders**



**LP / LPM Series - Low Profile**

Features	D2-D3
Ordering Information	D3
Specifications	D4
Technical Data	D5
Dimensional Data	D6-D8
Accessories	D9-D10

**D**

Compact  
Pneumatic Cylinders



Features

LP/LPM Series

- Reduces Design Height
- Light Weight
- Reduces Cylinder Overhang
- Specials Available

D

Compact  
Pneumatic Cylinders

LP/LPM  
Series

**PISTON ROD SEAL**

Buna-N quad seal provides positive sealing to keep pressure in and dirt out for less maintenance and trouble free performance.

**PISTON ROD**

High strength steel, hard chrome plated for reliable smooth performance, long life, and extended seal life.

**CYLINDER BODY**

Hard coated heavy wall aluminum alloy. The tube I.D. coating has extreme hardness, excellent wear and seizure resistance, low coefficient of friction, and high corrosion resistance. This provides excellent wear qualities and quick break-a-ways.

**PISTON**

Attached securely to the rod to provide maximum strength and durability.

**ROD BEARING**

High density iron provides maximum support for longer life.

**HEADS AND CAPS**

Anodized aluminum alloy for solid, lightweight, high strength performance. This provides excellent corrosion resistance, durability, and a long lasting quality appearance.

**PISTON SEAL**

Buna-N quad seal provides positive sealing with air.



## Features

- Low profile design
- Flexible construction with special modification capability
- High density iron rod bearing provides maximum support for longer life
- Single and double acting versions available
- 6 mounting styles
- 8 bore sizes from 9/16" to 4"
- Strokes from 1/8" to 6"
- Permanent lubrication
- Non-lube service



### Operating information

Operating pressure:	145 PSIG (10 bar)	
Temperature range:	LP	-10°F to 200°F (-23°C to 93°C)
	LPM	-10°F to 140°F (-23°C to 60°C)
Filtration requirements:	40 micron, dry filtered air	

## Ordering information

<b>1.50</b>	<b>K</b>	<b>N</b>	<b>LP</b>	<b>L</b>	<b>V</b>	<b>B</b>	<b>E</b>	<b>S</b>	<b>9</b>	<b>1.25"</b>																																																																													
<table border="1"> <tr><th colspan="2">Bore Size</th></tr> <tr><td>0.56</td><td>9/16"</td></tr> <tr><td>0.75</td><td>3/4"</td></tr> <tr><td>1.12</td><td>1-1/8"</td></tr> <tr><td>1.50</td><td>1-1/2"</td></tr> <tr><td>2.00</td><td>2"</td></tr> <tr><td>2.50</td><td>2-1/2"</td></tr> <tr><td>3.00</td><td>3"</td></tr> <tr><td>4.00</td><td>4"</td></tr> </table>	Bore Size		0.56	9/16"	0.75	3/4"	1.12	1-1/8"	1.50	1-1/2"	2.00	2"	2.50	2-1/2"	3.00	3"	4.00	4"	<table border="1"> <tr><th colspan="2">Double Rod Cylinder</th></tr> <tr><td>Blank</td><td>Single Rod</td></tr> <tr><td>K</td><td>Double Rod</td></tr> </table>	Double Rod Cylinder		Blank	Single Rod	K	Double Rod	<table border="1"> <tr><th colspan="2">Series</th></tr> <tr><td>LP</td><td>Standard</td></tr> <tr><td>LPM</td><td>Magnetic Piston<sup>5</sup></td></tr> </table>	Series		LP	Standard	LPM	Magnetic Piston <sup>5</sup>	<table border="1"> <tr><th colspan="2">Piston Seal</th></tr> <tr><td>Blank</td><td>Standard Seal</td></tr> <tr><td>L</td><td>Lipseal Piston Seal<sup>3</sup></td></tr> </table>	Piston Seal		Blank	Standard Seal	L	Lipseal Piston Seal <sup>3</sup>	<table border="1"> <tr><th colspan="2">Seals</th></tr> <tr><td>Blank</td><td>Standard</td></tr> <tr><td>V</td><td>Class 5 Seals</td></tr> </table>	Seals		Blank	Standard	V	Class 5 Seals	<table border="1"> <tr><th colspan="2">Bumpers*</th></tr> <tr><td>Blank</td><td>No Bumpers</td></tr> <tr><td>B</td><td>Bumpers Both Ends</td></tr> <tr><td>H</td><td>Head End Only<sup>6</sup></td></tr> <tr><td>C</td><td>Cap End Only<sup>4</sup></td></tr> </table>	Bumpers*		Blank	No Bumpers	B	Bumpers Both Ends	H	Head End Only <sup>6</sup>	C	Cap End Only <sup>4</sup>	<table border="1"> <tr><th colspan="2">Spring</th></tr> <tr><td>Blank</td><td>None</td></tr> <tr><td>E</td><td>Spring Extended</td></tr> <tr><td>R</td><td>Spring Return</td></tr> </table>	Spring		Blank	None	E	Spring Extended	R	Spring Return	<table border="1"> <tr><th colspan="2">Special features</th></tr> <tr><td>Blank</td><td>No Special Feature</td></tr> <tr><td>S</td><td>Special Feature</td></tr> </table>	Special features		Blank	No Special Feature	S	Special Feature	<table border="1"> <tr><th colspan="2">Rod End Thread Style</th></tr> <tr><td>9</td><td>Standard Female Rod End</td></tr> <tr><td>4</td><td>Optional Male Rod End</td></tr> <tr><td>3</td><td>Special Rod End (Specify Dimensions Or Sketch)</td></tr> </table>	Rod End Thread Style		9	Standard Female Rod End	4	Optional Male Rod End	3	Special Rod End (Specify Dimensions Or Sketch)	<table border="1"> <tr><th colspan="2">Stroke Length</th></tr> <tr><td colspan="2">Specify Stroke Length Required In Inches.</td></tr> </table>	Stroke Length		Specify Stroke Length Required In Inches.	
Bore Size																																																																																							
0.56	9/16"																																																																																						
0.75	3/4"																																																																																						
1.12	1-1/8"																																																																																						
1.50	1-1/2"																																																																																						
2.00	2"																																																																																						
2.50	2-1/2"																																																																																						
3.00	3"																																																																																						
4.00	4"																																																																																						
Double Rod Cylinder																																																																																							
Blank	Single Rod																																																																																						
K	Double Rod																																																																																						
Series																																																																																							
LP	Standard																																																																																						
LPM	Magnetic Piston <sup>5</sup>																																																																																						
Piston Seal																																																																																							
Blank	Standard Seal																																																																																						
L	Lipseal Piston Seal <sup>3</sup>																																																																																						
Seals																																																																																							
Blank	Standard																																																																																						
V	Class 5 Seals																																																																																						
Bumpers*																																																																																							
Blank	No Bumpers																																																																																						
B	Bumpers Both Ends																																																																																						
H	Head End Only <sup>6</sup>																																																																																						
C	Cap End Only <sup>4</sup>																																																																																						
Spring																																																																																							
Blank	None																																																																																						
E	Spring Extended																																																																																						
R	Spring Return																																																																																						
Special features																																																																																							
Blank	No Special Feature																																																																																						
S	Special Feature																																																																																						
Rod End Thread Style																																																																																							
9	Standard Female Rod End																																																																																						
4	Optional Male Rod End																																																																																						
3	Special Rod End (Specify Dimensions Or Sketch)																																																																																						
Stroke Length																																																																																							
Specify Stroke Length Required In Inches.																																																																																							
<table border="1"> <tr><th colspan="2">Mounting Style</th></tr> <tr><td>N</td><td>Basic (Std.)</td></tr> <tr><th colspan="2">Single Rod Styles</th></tr> <tr><td>4F</td><td>Head Bolt</td></tr> <tr><td>4R</td><td>Cap Bolt</td></tr> <tr><td>2F</td><td>Head Trunnion<sup>1</sup></td></tr> <tr><td>2R</td><td>Cap Trunnion<sup>1</sup></td></tr> <tr><td>1</td><td>Cap Pivot Eye</td></tr> <tr><th colspan="2">Double Rod Styles</th></tr> <tr><td>N</td><td>Basic</td></tr> <tr><td>4r</td><td>Cap Bolt</td></tr> <tr><td>2f</td><td>Head Trunnion</td></tr> <tr><th colspan="2">Hollow Rod Styles<sup>1,2,5,6</sup></th></tr> <tr><td>NH</td><td>Basic</td></tr> <tr><td>4RH</td><td>Cap Bolt</td></tr> <tr><td>2FH</td><td>Head Trunnion</td></tr> </table>		Mounting Style		N	Basic (Std.)	Single Rod Styles		4F	Head Bolt	4R	Cap Bolt	2F	Head Trunnion <sup>1</sup>	2R	Cap Trunnion <sup>1</sup>	1	Cap Pivot Eye	Double Rod Styles		N	Basic	4r	Cap Bolt	2f	Head Trunnion	Hollow Rod Styles <sup>1,2,5,6</sup>		NH	Basic	4RH	Cap Bolt	2FH	Head Trunnion	<p><b>Note:</b> For sensor specifications and part numbers, please refer to the Electronic Sensors section.</p>																																																					
Mounting Style																																																																																							
N	Basic (Std.)																																																																																						
Single Rod Styles																																																																																							
4F	Head Bolt																																																																																						
4R	Cap Bolt																																																																																						
2F	Head Trunnion <sup>1</sup>																																																																																						
2R	Cap Trunnion <sup>1</sup>																																																																																						
1	Cap Pivot Eye																																																																																						
Double Rod Styles																																																																																							
N	Basic																																																																																						
4r	Cap Bolt																																																																																						
2f	Head Trunnion																																																																																						
Hollow Rod Styles <sup>1,2,5,6</sup>																																																																																							
NH	Basic																																																																																						
4RH	Cap Bolt																																																																																						
2FH	Head Trunnion																																																																																						
<table border="1"> <tr><th colspan="2">Sensors</th></tr> <tr><td colspan="2">See section L for sensors.</td></tr> </table>										Sensors		See section L for sensors.																																																																											
Sensors																																																																																							
See section L for sensors.																																																																																							

For ordering purposes, when special options or common modifications are requested, the factory will assign a sequential part number in place of the model number.

**D**  
Compact  
Pneumatic Cylinders  
  
LP/LPM  
Series



For inventory, lead times, and kit lookup, visit [www.pdnplu.com](http://www.pdnplu.com)



**General Specifications**

- Low Profile Design
- 6 Mounting Styles
- 8 Bore Sizes from 9/16" to 4"
- Temperature Range: -10°F to 200°F  
 (LPM Series 140°F max.)
- Strokes from 1/8" to 6"
- Permanent Lubrication
- Maximum Operating Pressure: 145 PSI Air

**D**  
**Compact Pneumatic Cylinders**  
**LP/LPM Series**

**Push/Pull Forces**

Bore Dia.	Rod Area	Piston Area Push/Pull		PSI									
				40	50	60	80	100	125	150	175	200	250
9/16		Push	0.248	10	12.5	15	20	25	31	37	43	50	62
	0.048	Pull	0.200	8	10	12	16	20	25	30	35	40	50
3/4		Push	0.442	17.5	22	26.5	35	44	55	66	77	88	111
	0.076	Pull	0.366	14.6	18	22	29	37	46	55	64	73	92
1-1/8		Push	0.994	40	50	60	80	99	124	149	174	200	249
	0.196	Pull	0.798	32	40	48	64	80	100	120	140	160	200
1-1/2		Push	1.767	71	88	106	141	177	221	265	309	353	443
	0.307	Pull	1.460	58	73	88	117	146	182	219	256	292	365
2		Push	3.141	126	157	188	251	314	393	471	550	628	785
	0.442	Pull	2.699	108	135	162	216	270	337	405	472	540	675
2-1/2		Push	4.908	196	245	294	393	491	613	736	859	982	1227
	0.442	Pull	4.466	178	223	268	357	447	558	670	781	893	1116
3		Push	7.069	283	353	424	566	707	884	1060	1237	1414	1767
	.601	Pull	6.468	259	324	389	519	649	811	973	1135	1297	1622
4		Push	12.57	503	628	754	1006	1257	1571	1885	2200	2514	3142
	0.781	Pull	11.79	471	589	707	942	1178	1484	1767	2062	2356	2945

**Weights – Basic Cylinders**

Bore Dia.	Basic N Mount Weight in Ounces*	Add per 1/8" of Stroke (ounces)
9/16	1.1	0.08
3/4	2.0	0.1
1-1/8	5.0	0.2
1-1/2	8.5	0.4
2	11.7	0.5
2-1/2	18.6	0.6
3	25.1	0.7
4	51.1	1.1

\* Base weight includes 1/8 inch of stroke.

**Tie Rod Torque**

Bore	Torque (inch pounds)
9/16	8 - 10
3/4	20 - 25
1-1/8	20 - 25
1-1/2	35 - 40
2	35 - 40
2-1/2	50 - 60
3	70 - 80
4	150 - 160



For inventory, lead times, and kit lookup, visit [www.pdnplu.com](http://www.pdnplu.com)

**Noise Dampening Bumpers**

Bumpers both ends – B  
 Bumpers rod end – R  
 Bumper cap end – C\*

Bumpers are available at either or both ends of the cylinder to reduce noise for quieter operation. Bumper material is a 70 durometer nitrile.

The table shows the distance the stroke is reduced when incorporating bumpers. This varies with operating pressure as indicated in the table.

**Example:** 1.50 NL PB9 x 0.50" stroke. Bumpers both ends cylinder will have a working stroke of 0.43" instead of 0.50" operating at 80 psi. For special applications call the factory.

**NOTES:**

Bumpers shorten actual strokes and are not practical on short stroke with low operating pressure.

Bumpers on Cap End or Both Ends will add the "BC" length in chart to "C" dimension (rod extension).

Bumpers on Double End Cylinders will add the "BR" length in chart to the "C" dimension (rod extension).

\* Not available on spring extend.

**Stroke Reduction (in.) Using Bumpers**

Bore Dia.	Bumper Location	Dim.	Operating Pressure (PSI)					
			0	20	40	60	80	100
0.56	Cap End	BC	0.03	0.02	0.02	0.01	0.01	0.01
	Head End	BR	0.07	0.07	0.06	0.06	0.05	0.04
	Both Ends	BB	0.10	0.09	0.08	0.07	0.06	0.05
0.75	Cap End	BC	0.07	0.07	0.06	0.05	0.05	0.04
	Head End	BR	0.07	0.06	0.05	0.05	0.04	0.03
	Both Ends	BB	0.14	0.13	0.11	0.10	0.09	0.07
1.12	Cap End	BC	0.10	0.09	0.09	0.07	0.07	0.06
	Head End	BR	0.10	0.09	0.08	0.07	0.07	0.06
	Both Ends	BB	0.20	0.18	0.17	0.14	0.14	0.12
1.50	Cap End	BC	0.11	0.10	0.09	0.08	0.07	0.06
	Head End	BR	0.10	0.08	0.08	0.07	0.06	0.06
	Both Ends	BB	0.21	0.18	0.17	0.15	0.13	0.12
2.00	Cap End	BC	0.11	0.09	0.08	0.07	0.06	0.05
	Head End	BR	0.10	0.08	0.06	0.06	0.06	0.05
	Both Ends	BB	0.21	0.17	0.14	0.13	0.12	0.10
2.50	Cap End	BC	0.08	0.06	0.05	0.03	0.03	0.03
	Head End	BR	0.10	0.07	0.06	0.05	0.05	0.04
	Both Ends	BB	0.18	0.13	0.11	0.08	0.08	0.07
3.00	Cap End	BC	0.10	0.06	0.04	0.03	0.02	0.01
	Head End	BR	0.14	0.09	0.08	0.08	0.07	0.07
	Both Ends	BB	0.24	0.15	0.12	0.11	0.09	0.08
4.00	Cap End	BC	0.10	0.08	0.05	0.03	0.03	0.02
	Head End	BR	0.21	0.15	0.13	0.12	0.11	0.11
	Both Ends	BB	0.31	0.23	0.18	0.15	0.14	0.13

**Sensor Mounting Data**

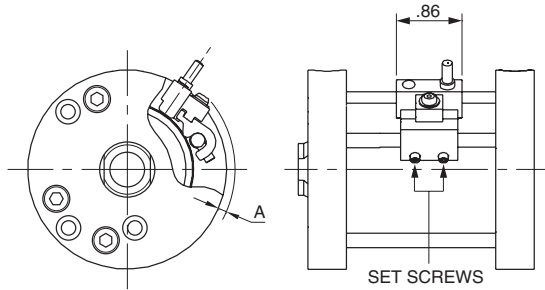

To sense piston position, mount sensor along tie rod using 2 each small set screws.

Size	A	Piston Travel at Midstroke (in ±0.01) (Sensor On)	Minimum Activation Distance from End of Stroke (in)	
			Head	Cap
9/16	0.32	0.20	0.13	0.13
3/4	0.25	0.23	0.13	0.13
1-1/8	0.20	0.32	0.13	0.13
1-1/2	0.10	0.32	0.07	0.07
2	0.10	0.35	0.06	0.06
2-1/2	0.03	0.42	0.06	0.06
3	0.03	0.47	0.12	0.12
4	0.00	0.47	0.12	0.12

**Seal Kits**

**Standard Piston**

		Single Rod Cylinders	
Bore Size	Rod Dia.	Class 1 Seals Part No.	Class 5 Seals Part No.
9/16	1/4"	SKS05LP251	SKS05LP255
3/4	5/16"	SKS07LP311	SKS07LP315
1-1/8	1/2"	SKS12LP501	SKS12LP505
1-1/2	5/8"	SKS15LP621	SKS15LP625
2	3/4"	SKS20LP751	SKS20LP755
2-1/2	3/4"	SKS25LP751	SKS25LP755
3	7/8"	SKS30LP871	SKS30LP875
4	1"	SKS40LP101	SKS40LP105

**Lipseal Piston**

		Single Rod Cylinders	
Bore Size	Rod Dia.	Class 1 Seals Part No.	Class 5 Seals Part No.
9/16	1/4"	KS05LPL251	KS05LPL255
3/4	5/16"	KS07LPL311	KS07LPL315
1-1/8	1/2"	KS12LPL501	KS12LPL505
1-1/2	5/8"	KS15LPL621	KS15LPL625
2	3/4"	KS20LPL751	KS20LPL755
2-1/2	3/4"	KS25LPL751	KS25LPL755
3	7/8"	KS30LPL871	KS30LPL875
4	1"	KS40LPL101	KS40LPL105



For inventory, lead times, and kit lookup, visit [www.pdnplu.com](http://www.pdnplu.com)

**Mounting Style N**

Cylinder Dimensions  
 Double Acting  
 Single Rod End,  
 Female Rod Style No. 9

Temperature: -10°F  
 to 200°F (optional  
 Fluorocarbon seals).  
 All air cylinders are  
 permanently lubricated.  
 LPM Series maximum  
 temperature 140°F.

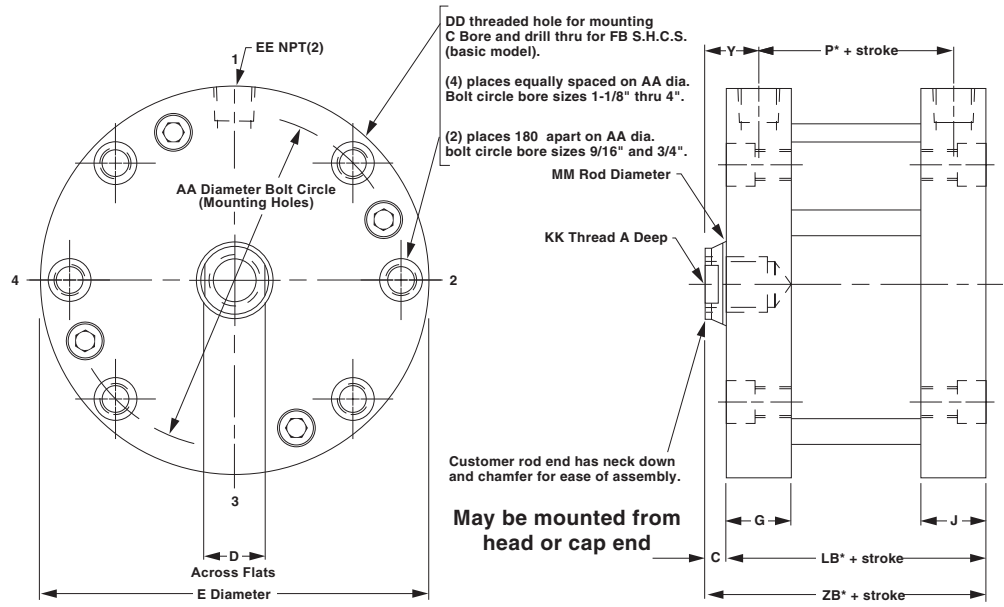

Bore Size	A	C	D	E	G	J	P*	Y	AA	DD	EE	FB	KK	LB*	MM	ZB*
9/16	0.40	1/8	7/32	1-1/8	23/64	23/64	11/32	17/64	0.875	#8-32	#10-32	#4	#8-32	5/8	1/4	3/4
3/4	0.44	1/8	1/4	1-1/2	23/64	23/64	3/8	17/64	1.219	#10-32	#10-32	#6	#10-32	21/32	5/16	25/32
1-1/8	0.62	1/8	7/16	2	1/2	1/2	27/64	3/8	1.687	#10-32	1/8	#6	5/16-24	59/64	1/2	1-3/64
1-1/2	0.62	1/8	1/2	2-5/8	1/2	1/2	1/2	3/8	2.187	1/4-28	1/8	#10	3/8-24	1	5/8	1-1/8
2	0.70†	1/8	5/8	3-1/8	1/2	1/2	9/16	3/8	2.687	1/4-28	1/8	#10	1/2-20	1-1/16	3/4	1-3/16
2-1/2	0.70†	1/8	5/8	3-3/4	5/8	5/8	5/8	7/16	3.250	5/16-24	1/4	.406	1/2-20	1-1/4	3/4	1-3/8
3	0.75†	1/8	3/4	4-1/4	43/64	43/64	21/32	7/16	3.781	5/16-24	1/4	.406	5/8-18	1-9/32	7/8	1-13/32
4	0.75†	1/8	7/8	5-1/2	27/32	27/32	49/64	17/32	4.937	3/8-24	3/8	5/16	3/4-16	1-5/8	1	1-3/4

\* These dimensions are for the LP Series with standard piston.  
 † For strokes less than 0.25", A dimension = 0.66".

**Added length table for LPM or lipseal piston options**

Bore Size	LPM Option*						LP with Lipseal Piston Option				
	P	LB	XD	XJ	ZB	Stroke	P	LB	XD	XJ	ZB
9/16†	15/16	1-7/32	2	-	1-11/32	1/2	5/8	29/32	1-11/16	-	1-1/32
3/4†	31/32	1-1/4	2-1/32	1-3/16	1-3/8	1/2	21/32	15/16	1-23/32	7/8	1-1/16
1-1/8†	63/64	1-31/64	2-3/8	1-23/64	1-39/64	9/16	43/64	1-11/64	2-1/16	1-3/64	1-19/64
1-1/2	1-1/8	1-5/8	2-13/16	1-1/2	1-3/4	7/16	13/16	1-5/16	2-1/2	1-3/16	1-7/16
2	1-9/32	1-25/32	3-1/32	1-21/32	1-29/32	7/16	61/64	1-29/64	2-45/64	1-21/64	1-37/64
2-1/2	1-21/64	1-61/64	3-21/64	1-3/4	2-5/64	1/2	1	1-5/8	3	1-27/64	1-3/4
3	1-27/64	2-3/64	3-53/64	1-53/64	2-11/64	1/2	1-3/32	1-23/32	3-1/2	1-1/2	1-27/32
4	1-1/2	2-23/64	4-11/64	2	2-31/64	1/2	1-11/64	2-1/32	3-27/32	1-43/64	2-5/32

Note minimum strokes for LPM option.  
 † These bore sizes not available for the LPM option with the hollow rod option.  
 \* The LPM option is only available with the standard quad seal.

**D**  
 Compact  
 Pneumatic Cylinders  
 LP/LPM  
 Series



For inventory, lead times, and kit  
 lookup, visit [www.pdnplu.com](http://www.pdnplu.com)

**Head Bolt Clearance Holes**

Mounting Style 4F  
 Available Head End

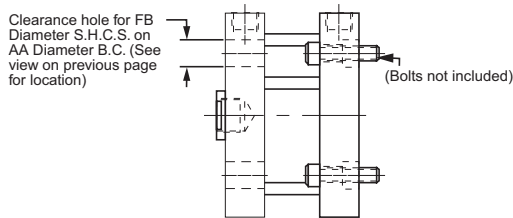

**Cap Bolt Clearance Holes**

Mounting Style 4R  
 Available Cap End

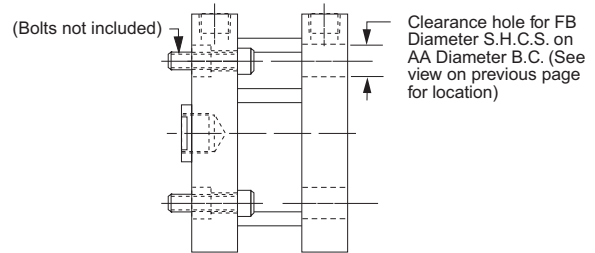

**Head Trunnion**

Mounting Style 2F (9/16" bore not available)

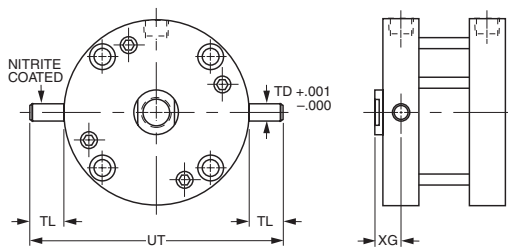

**Cap Trunnion**

Mounting Style 2R (9/16" bore not available)

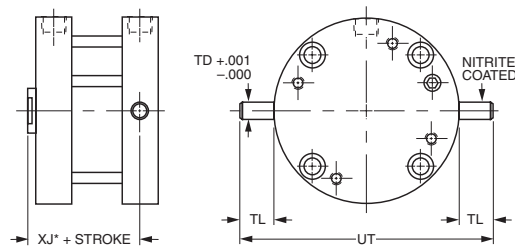

Bore Size	TD	TL	UT	XG	XJ*
3/4	0.125	5/16	2-1/8	5/16	19/32
1-1/8	0.250	1/2	3	3/8	51/64
1-1/2	0.250	1/2	3-5/8	3/8	7/8
2	0.250	1/2	4-1/8	3/8	15/16
2-1/2	0.312	5/8	5	29/64	1-3/64
3	0.312	5/8	5-1/2	15/32	1-1/16
4	0.375	3/4	7	35/64	1-17/64

\* These dimensions are for the LP Series with standard piston.

**Cap Pivot Eye**

Mounting Style 1

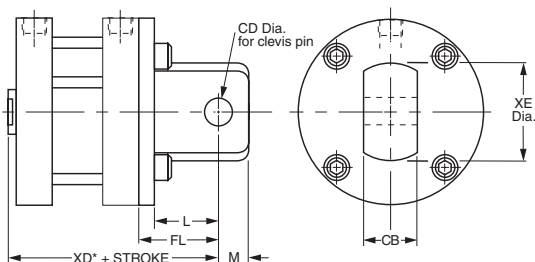

Bore Size	L	M	CB	CD	FL	XD*	XE
9/16	1/2	1/4	3/8	3/16	21/32	1-13/32	19/32
3/4	1/2	1/4	3/8	3/16	21/32	1-7/16	3/4
1-1/8	1/2	1/4	3/8	3/16	49/64	1-13/16	3/4
1-1/2	13/16	7/16	3/4	3/8	1-1/16	2-3/16	1-3/8
2	13/16	7/16	3/4	3/8	1-1/8	2-5/16	1-3/8
2-1/2	13/16	7/16	3/4	3/8	1-1/4	2-5/8	1-3/8
3	1-9/32	9/16	1	5/8	1-21/32	3-1/16	1-7/8
4	1-9/32	9/16	1	5/8	1-11/16	3-7/16	1-7/8

Order clevis pin from accessories when required.

\* These dimensions are for the LP Series with standard piston. See table on the previous page for dimensions for the lipseal piston or LPM options.



For inventory, lead times, and kit lookup, visit [www.pdnplu.com](http://www.pdnplu.com)

## Dimensional Data

## Compact Pneumatic Cylinders LP/LPM Series

### Spring Extend & Spring Return Cylinders

(Available through 2" stroke)

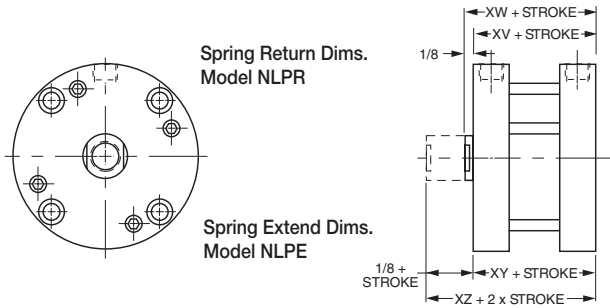

### Double Rod Spring Extend & Spring Return Cylinders

(Available through 2" stroke)

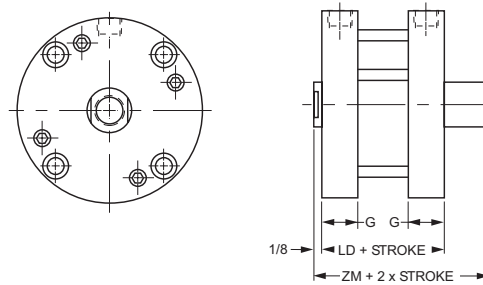

**D**  
Compact  
Pneumatic Cylinders

LP/LPM  
Series

Bore Size	1/8" to 1" stroke				Over 1" to 2" stroke				Add This Length to XV, XW, XY, XZ for Lipseal Piston
	XV	XW	XY	XZ	XV	XW	XY	XZ	
9/16	1	1-1/8	57/64	1-1/64	1-11/16	1-13/16	1-37/64	1-45/64	9/32
3/4	1-1/64	1-9/64	59/64	1-3/64	1-45/64	1-53/64	1-39/64	1-47/64	9/32
1-1/8	1-23/64	1-31/64	1-9/32	1-13/32	1-63/64	2-7/64	1-29/32	2-1/32	1/4
1-1/2	1-25/64	1-33/64	1-11/32	1-15/32	2-1/64	2-9/64	1-31/32	2-3/32	5/16
2	1-11/64	1-19/64	1-13/32	1-17/32	1-51/64	1-59/64	2-1/32	2-5/32	25/64
2-1/2	1-3/8	1-1/2	1-23/32	1-27/32	2	2-1/8	2-11/32	2-15/64	3/8
3	1-1/2	1-5/8	1-55/64	1-63/64	2-1/8	2-1/4	2-31/64	2-39/64	7/16
4	1-27/32	1-31/32	2-13/64	2-21/64	2-15/32	2-19/32	2-53/64	2-61/64	13/32

Bore Size	Spring Return/Extend – LP						Spring Return/Extend – LPM					
	≥ 1/8", ≤ 1"			<1", ≤ 2"			≥ 1/8", >1"			>1", ≤ 2"		
	G	LD	ZM	Min.* stroke	LD	ZM	LD	ZM	Min.* stroke	LD	ZM	
9/16	23/64	1-1/8	1-3/8	5/16	1-13/16	2-1/16	1-23/32	1.97	3/16	2-13/32	2.66	
3/4	23/64	1-11/64	1-27/64	1/8	1-55/64	2-7/64	1-49/64	2.02	3/16	2-29/64	2.70	
1-1/8	1/2	1-1/2	1-3/4	1/8	2-1/8	2-3/8	2-1/16	2.44	1/8	2-11/16	2.94	
1-1/2	1/2	1-11/16	1-15/16	1/8	2-5/16	2-9/16	2-5/16	2.56	1/4	2-15/16	3.19	
2	1/2	1-31/64	1-47/64	1/8	2-7/64	2-23/64	2-13/64	2.45	1/4	2-53/64	3.08	
2-1/2	5/8	1-3/4	2	1/8	2-3/8	2-5/8	2-29/64	2.70	3/16	3-5/64	3.33	
3	43/64	1-29/32	2-5/32	1/8	2-17/32	2-25/32	2-43/64	2.92	1/8	3-19/64	3.55	
4	27/32	2-1/4	2-1/2	1/8	2-7/8	3-1/8	2-63/64	3.23	1/8	3-39/64	3.86	

\* Note minimum strokes for LPM option.

### Spring force data

1/8" to 1" stroke			Over 1" to 2" stroke		
Bore Size	Max. Spring Force (lbs)	Spring Rate (lb/in)	Bore Dia.	Max. Spring Force (lbs)	Spring Rate (lb/in)
9/16	5.7	4.25	9/16	5.7	1.75
3/4	9	6	3/4	9	2.5
1-1/8	10	6	1-1/8	10	2.5
1-1/2	13	5.5	1-1/2	12	2.25
2	13	5.5	2	12	2.25
2-1/2	17.5	6	2-1/2	16	2.5
3 & 4	24	6.5	3 & 4	23	2.75



For inventory, lead times, and kit lookup, visit [www.pdnplu.com](http://www.pdnplu.com)

D8

**Parker Hannifin Corporation**  
Pneumatic Division  
Wadsworth, Ohio  
[www.parker.com/pneumatics](http://www.parker.com/pneumatics)

**Optional Male Rod End**

Specify #4

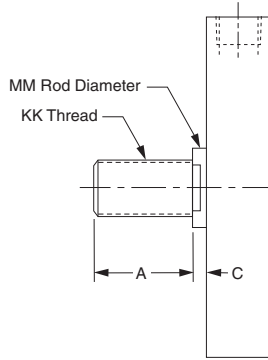

Bore Size	A	C	KK	MM
9/16	0.38	1/8	#8-32	1/4
3/4	0.50	1/8	#10-32	5/16
1-1/8	0.50	1/8	5/16-24	1/2
1-1/2	0.50	1/8	3/8-24	5/8
2	0.62	1/8	1/2-20	3/4
2-1/2	0.62	1/8	1/2-20	3/4
3	0.75	1/8	5/8-18	7/8
4	0.75	1/8	3/4-16	1

**Non-standard Rods**

For non-standard rod ends, please specify rod thread style 3 and provide the KK, A, and C dimensions as needed.

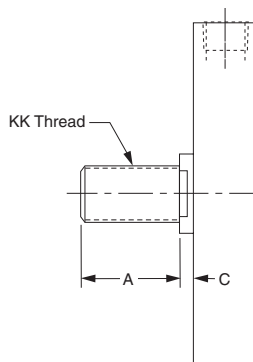

**Double or Hollow Rod Cylinders**

Note: Cylinders with hollow rod option should not be bottomed out during stroke.

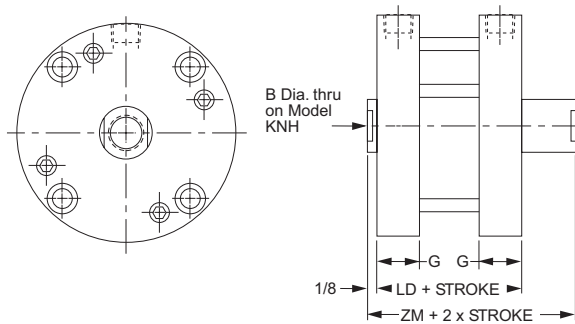

**LP double or hollow rod option, LPM, lipseal piston**

Bore Size	B	G	Standard Double Rod End Or With Hollow Rod		LPM Option		LP with Lipseal Piston Option	
			LD	ZM	LD	ZM	LD	ZM
9/16	*	23/64	3/4	1	1-11/32	1.59	1-1/32	1-9/32
3/4	9/64	23/64	13/16	1-1/16	1-13/32	1.66	1-3/32	1-11/32
1-1/8	7/32	1/2	1-3/16	1-7/16	1-3/4	2.00	1-7/16	1-11/16
1-1/2	9/32	1/2	1-19/64	1-35/64	1-59/64	2.19	1-39/64	1-55/64
2	3/8	1/2	1-3/8	1-5/8	2-3/32	2.34	1-49/64	2-1/64
2-1/2	3/8	5/8	1-5/8	1-7/8	2-21/64	2.58	2	2-1/4
3	7/16	43/64	1-11/16	1-15/16	2-29/64	2.70	2-1/8	2-3/8
4	1/2	27/32	2-1/32	2-9/32	2-49/64	3.01	2-7/16	2-11/16

\*Hollow rod not available on 9/16" bore.

**D**  
 Compact Pneumatic Cylinders  
 LP/LPM Series



For inventory, lead times, and kit lookup, visit [www.pdnplu.com](http://www.pdnplu.com)

Rod Eye

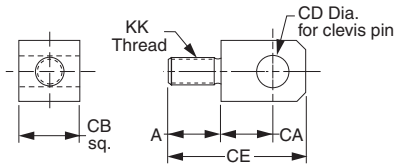

Bore Size	A	CA	CB	CD	CE	KK	Part Number
9/16	3/8	15/32	3/8	3/16	1-3/32	#8-32	L073810008
3/4	3/8	15/32	3/8	3/16	1-3/32	#10-32	L073810010
1-1/8	9/16	15/32	3/8	3/16	1-9/32	5/16-24	L073810020
1-1/2	5/8	23/32	3/4	3/8	1-25/32	3/8-24	L073810024
2-2-1/2	21/32	23/32	3/4	3/8	1-27/32	1/2-20	L073810032
3	21/32	1	1	5/8	2-3/8	5/8-18	L073810040
4	21/32	1	1	5/8	2-3/8	3/4-16	L073810048

Clevis Bracket

(Supplied with Pin)

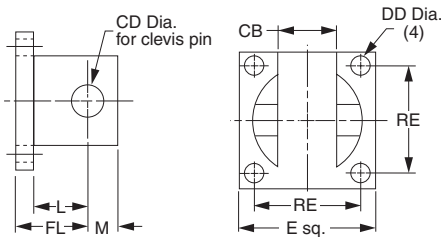

E	L	M	CB	CD	DD	FL	RE	Part Number
1	13/32	7/32	25/64	3/16	9/64	9/16	3/4	L073820012
1-3/4	25/32	13/32	49/64	3/8	11/64	15/16	1-3/8	L073820024
2-1/2	1	9/16	1-1/64	5/8	17/64	1-1/4	2	L073820040

Use L073820012 on 9/16", 3/4" and 1-1/8" bore.  
Use L073820024 on 1-1/2", 2" and 2-1/2" bore.  
Use L073820040 on 3" and 4" bore.

**Note:** The Clevis Bracket is an accessory for the rod eye or the cap pivot eye and cannot be mounted directly to the cylinder.

Trunnion Bracket

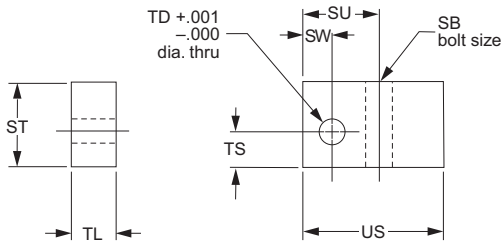

SB	ST	SU	SW	TD	TL	TS	US	Part Number
1/4	7/8	13/16	5/16	.252	1/2	3/8	1-1/2	L073840016
5/16	1	15/16	3/8	.314	5/8	29/64	1-5/8	L073840020
3/8	1-1/4	1-1/16	7/16	.377	3/4	35/64	1-7/8	L073840024

Use L073840016 on 1-1/8", 1-1/2" and 2" bore.  
Use L073840020 on 2- 1/2" and 3" bore.  
Use L073840024 on 4" bore.

Clevis Pin

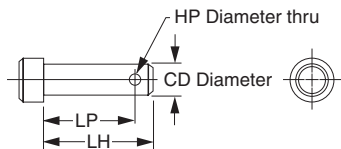

CD	HP	LH	LP	Part Number
3/16	3/32	1	29/32	L073830012
3/8	5/32	1-5/8	1-15/32	L073830024
5/8	5/32	2	1-27/32	L073830040

Service Kits

Bore Size	Rod Dia.	Standard Piston, Single Rod Cylinders		Lipseal Piston, Single Rod Cylinders	
		Class 1 Seals Part Number	Class 5 Seals Part Number	Class 1 Seals Part Number	Class 5 Seals Part Number
9/16	1/4"	SKS05LP251	SKS05LP255	KS05LPL251	KS05LPL255
3/4	5/16"	SKS07LP311	SKS07LP315	KS07LPL311	KS07LPL315
1-1/8	1/2"	SKS12LP501	SKS12LP505	KS12LPL501	KS12LPL505
1-1/2	5/8"	SKS15LP621	SKS15LP625	KS15LPL621	KS15LPL625
2	3/4"	SKS20LP751	SKS20LP755	KS20LPL751	KS20LPL755
2-1/2	3/4"	SKS25LP751	SKS25LP755	KS25LPL751	KS25LPL755
3	7/8"	SKS30LP871	SKS30LP875	KS30LPL871	KS30LPL875
4	1"	SKS40LP101	SKS40LP105	KS40LPL101	KS40LPL105



For inventory, lead times, and kit lookup, visit [www.pdnplu.com](http://www.pdnplu.com)

**D**  
 Compact Pneumatic Cylinders  
 LP/LPM Series



**Guided Design**  
**Pneumatic Cylinders**

<b>Selection Guide</b>	E2
------------------------	----

**P5T Series**

Features	E3-E4
Ordering Information	E4
Specifications	E5-E6
Dimensional Data	E7
Options	E8-E13



**HB Series - Compact, Thrust, Reach**

Features	E14-E15
Ordering Information	E15
Specifications	E16
Engineering Data	E17
Dimensional Data	E18-E21
Options	E22-E32

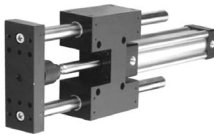

**P5E Series**

Features	E33-E34
Ordering Information	E34
Specifications	E35
Engineering Data	E35
Dimensional Data	E36
Options	E37-E42



**Virtual Engineer is an innovative design tool for Parker pneumatic actuators. Save engineering time with three simple steps:**

- 1) Enter application details using the intuitive interface
- 2) Size and select products that meet the demands of your specific application
- 3) Get a quote, share your project, and download files easily

Please visit Virtual Engineer to learn more and accurately size your pneumatic actuator requirements:

<http://solutions.parker.com/virtualEngineer>

**Selection Guide**

Basic performance features of the product line are shown below. See catalog sections for greater detail and ordering information. Consult factory for requirements beyond the scope of these guidelines.

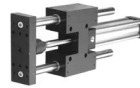

Cylinder Type	Built-in	NFPA/ISO Round	ISO
Series	P5T	HB	P5E
Bore Size Range	16 to 100mm	3/4 to 1-1/4 Round Body 32 to 63mm ISO 1-1/2" to 2-1/2" NPFA	32 to 100mm
Maximum Pressure Rating	10 Bar (145 PSI)	150 PSI	10 Bar (145 PSI)
Shaft Bearing Type	Composite or Linear Ball Bushings	Composite or Linear Ball Bushings	Composite or Linear Ball Bushings
Non-Lube Service	●	●	●
Sensor Options	Solid State	●	●
	Reed	●	●
	Proximity	●	
Mounting Faces	2	4	3
Mounting Through Holes		●	
Mounting T-Slots			
Stroke Adjustment	●	●	●
Piston Magnet Standard	●	●	●
Energy Dissipation	Cushions	●	●
	Bumpers	●	●
	Shock Absorbers		●
Port Relocation	●	●	
3-Position		●	●
Rod Lock Option		●	●
Hydraulic Service Option		●	●
Alignment Coupler		●	●
Fluorocarbon Seals	●	●	●
Corrosion Resistant	●	●	●

● = Available from catalog  
C = Consult Factory

**Guided Cylinders**

**P5T Series**

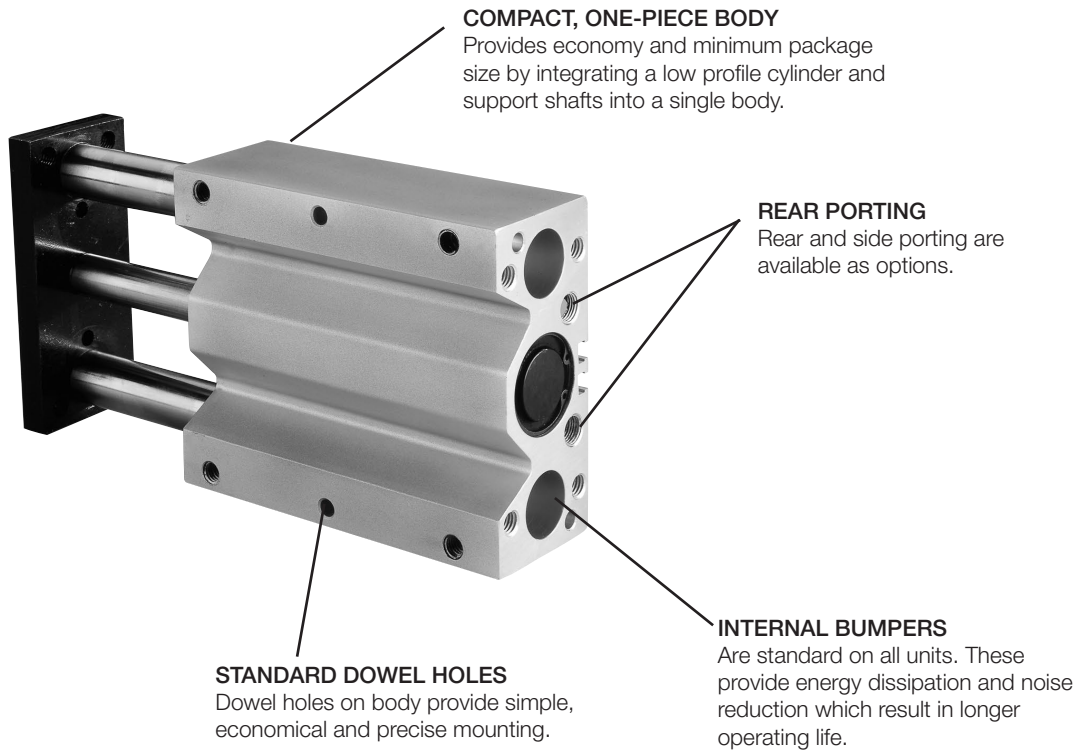

**TOP PORTING**  
Top porting is standard. Optional side and rear porting is available.

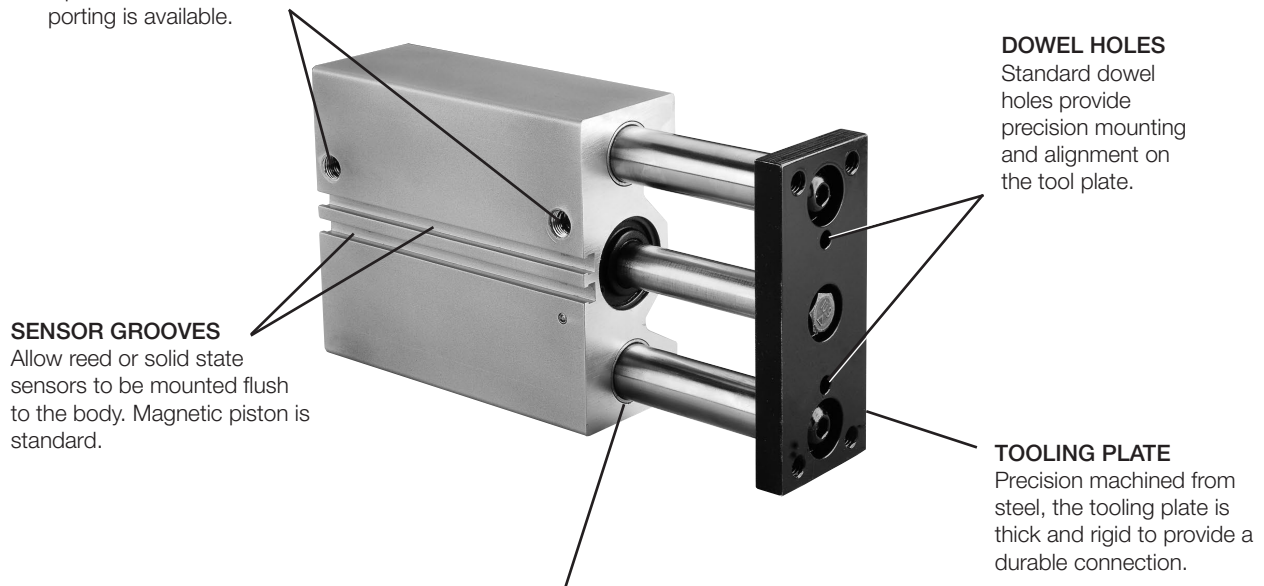

**COMPOSITE BUSHINGS OR LINEAR BALL BEARINGS**  
Parker uses a PTFE impregnated composite bushing which serves as a lubrication reservoir. This results in higher load carrying capabilities, both dynamic and static, with excellent resistance to shock loading. The impregnated lubricant also makes the bearings more dirt tolerant. **Composite bushings with oversized shafting** are available for high impact loads. Optional **recirculating ball bearings** provide precision operation with very low friction and wear.

E
Guided Cylinders
P5T Series
HB Series
P5E Series

Features

- Compact guided cylinder for short stroke applications
- 9 Bore sizes, 16mm to 100mm
- Strokes 10 to 400mm depending on model
- Standard dowel holes on body and tool plate
- High load bearing option
- Internal bumpers and magnetic piston are standard
- Flexible porting: top, rear, side



Operating information

Operating pressure: 145 PSIG (10 Bar / 1 MPa)  
 Temperature range:  
 Nitrile seals (standard) 0°F to 165°F (-18°C to 74°C)  
 Fluorocarbon seals\* 0°F to 250°F (-18°C to 121°C)  
 \* See fluorocarbon seal option for high temperature applications.  
 Filtration requirements: 40 micron, dry filtered air

Ordering information

**P5T - J 032 D H S N 100**

Shaft / Bearing Type		Bore Size		Seals		Options		Stroke Length									
<b>J</b>	Composite Bearing, Chrome Plated Shaft (std)	<b>016</b>	16mm	<b>S</b>	Nitrile (std)	<b>N</b>	None (std)	See Table Below for Standard Stroke Lengths. Consult Factory for Special Stroke Lengths.									
<b>H</b>	Ball Bearing, Stainless Steel Shaft	<b>020</b>	20mm	<b>F</b>	Fluorocarbon (high temp)	<b>B</b>	High Load Bearings <sup>2</sup>										
<b>C</b>	Composite Bearing, Stainless Steel Shaft	<b>025</b>	25mm	<table border="1"> <thead> <tr> <th colspan="2">Port Location / Mounting</th> </tr> </thead> <tbody> <tr> <td><b>D</b></td> <td>Dowel Holes, Top Ports (std)</td> </tr> <tr> <td><b>R</b></td> <td>Dowel Holes, Rear Ports, Top Plugged (std)<sup>9</sup></td> </tr> <tr> <td><b>S</b></td> <td>Dowel Holes, Side Ports and Top Ports<sup>1</sup></td> </tr> </tbody> </table>						Port Location / Mounting		<b>D</b>	Dowel Holes, Top Ports (std)	<b>R</b>	Dowel Holes, Rear Ports, Top Plugged (std) <sup>9</sup>	<b>S</b>	Dowel Holes, Side Ports and Top Ports <sup>1</sup>
Port Location / Mounting																	
<b>D</b>	Dowel Holes, Top Ports (std)																
<b>R</b>	Dowel Holes, Rear Ports, Top Plugged (std) <sup>9</sup>																
<b>S</b>	Dowel Holes, Side Ports and Top Ports <sup>1</sup>																
		<b>032</b>	32mm			<b>A</b>	Bumpers, Adjustable Stop Collars (extend only) and Dual Tool Plate (side ports rec) <sup>3,4</sup>										
		<b>040</b>	40mm			<b>E</b>	Bumpers and Adjustable Stop Collars (extend only) <sup>3</sup>										
		<b>050</b>	50mm			<b>G</b>	High Load Bearings, Bumpers and Adjustable Stop Collars (extend only) <sup>2,3</sup>										
		<b>063</b>	63mm			<b>D</b>	Dual Tool Plate <sup>3,4</sup>										
		<b>080</b>	80mm			<b>X</b>	Special										
		<b>100</b>	100mm														

Port Style		Stroke Type	
<b>H</b>	NPTF (std)	<b>Blank</b>	Standard Stroke (std hsg), or Special Stroke (custom hsg)
<b>G</b>	BSPP	<b>T</b>	Special Stroke (std hsg) <sup>5</sup>
<b>P</b>	Flow Control, BSPP Port, Prestolok Tube (mm) <sup>1</sup>		
<b>F</b>	Flow Control, NPTF Port, Prestolok Tube (inch) <sup>1</sup>		
<b>B</b>	Flow Control, BSPP <sup>1</sup>		
<b>N</b>	Flow Control, NPTF <sup>1</sup>		

  

Standard Strokes (mm)*														
Bore Size (mm)	10	25	40	50	75	100	125	150	175	200	250	300	350	400
16	•	•	•	•	•	•								
20		•	•	•	•	•								
25		•		•	•	•	•							
32		•		•	•	•	•	•						
40		•		•	•	•	•	•	•					
50		•		•	•	•	•	•	•	•				
63		•		•	•	•	•	•	•	•	•			
80		•		•	•	•	•	•	•	•	•	•		
100		•		•	•	•	•	•	•	•	•	•	•	

**NOTES:**  
<sup>1</sup> Cannot combine flow controls, side ports and 25mm stroke.  
<sup>2</sup> Not available with rear ports.  
<sup>3</sup> Not available with rear port location (R).  
<sup>4</sup> Includes high load bearings as standard.  
<sup>5</sup> Dimensions for special stroke length actuators will be the same as those of the next longest stroke actuator.  
<sup>9</sup> Not available above 200 mm stroke.

**Sensors**  
See section I for sensors.



Guided Cylinders  
 P5T Series  
 HB Series  
 P5E Series



For inventory, lead times, and kit lookup, visit [www.pdnplu.com](http://www.pdnplu.com)

**General Specifications****Specifications**

- Maximum operating pressure: 145 PSIG (10 Bar / 1 MPa)
- Operating characteristics: Double acting
- Support rod sizes: ø8 to 35mm
- Mounting: Unrestricted
- Operating temperature range (cylinder):
- Nitrile seals (standard) -18° to 74°C (0° to 165°F)
- Fluorocarbon seals\* -18° to 121°C (0° to 250°F)
- Filtration requirement: 40 micron, filtered dry air

\* See Fluorocarbon seal option for high temperature applications.

Online sizing: <http://solutions.parker.com/virtualEngineer>

**Construction**

Body	Aluminum
End Caps	Aluminum
Tool Plate	Steel
Piston Rod	Stainless Steel
Support Rods	Steel (Chrome Plated)
Rod Bolts	Steel

**Quick Reference Data**

Model (bore size)	Piston Rod (mm)	Bushings	Support Rods (mm)	Piston Bore Area Non-Rod Side		Max Stroke (mm)	Theoretical Force			
				mm <sup>2</sup>	in <sup>2</sup>		Extend @75 PSI (0.5 MPa)		Retract @75 PSI (0.5 MPa)	
							N	lb	N	lb
16	8	Ball	8	200	0.31	100	105	23.6	77.4	17.4
		Composite	10	200	0.31	100	105	23.6	77.4	17.4
20	10	Ball	10	316	0.49	125	164	36.8	123	27.8
		Composite	12	316	0.49	125	164	36.8	123	27.8
25	10	Ball	12	490	0.76	150	254	57	213.5	48
		Composite	16	490	0.76	150	254	57	213.5	48
32	16	Ball	16	804	1.25	200	402	93	302	70
		Composite	20	804	1.25	200	402	93	302	70
40	16	Ball	16	1257	1.95	200	628	146	528	123
		Composite	20	1257	1.95	200	628	146	528	123
50	20	Ball	20	1964	3.04	200	982	228	825	192
		Composite	25	1964	3.04	200	982	228	825	192
63	20	Ball	20	3117	4.83	200	1559	362	1492	326
		Composite	25	3117	4.83	200	1559	362	1492	326
80	25	Ball	25	5027	7.79	200	2513	584	2268	527
		Composite	30	5027	7.79	200	2513	584	2268	527
100	25	Ball	30	7854	12.17	200	3927	913	3574	856
		Composite	35	7854	12.17	200	3927	913	3574	856

**Mounting Bolts**

Bore Size	Socket Head Cap
16	M5 x .8
20	M5 x .8
25	M6 x 1.0
32	M8 x 1.25
40	M8 x 1.25
50	M10 x 1.5
63	M10 x 1.5
80	M12 x 1.75
100	M14 x 2.0

Note: When the P5T is used as an impact stopping system, mounting bolt thread engagement should be 1.5 times bolt diameter.



Guided  
Cylinders

P5T  
Series

HB  
Series

P5E  
Series



For inventory, lead times, and kit lookup, visit [www.pdnplu.com](http://www.pdnplu.com)

E5

Parker Hannifin Corporation  
Pneumatic Division  
Wadsworth, Ohio  
[www.parker.com/pneumatics](http://www.parker.com/pneumatics)

**Weights**

**Units with Composite Bushings**

Weights in kg (lb)

Model	Standard Stroke (mm)													
	10	25	40	50	75	100	125	150	175	200	250	300	350	400
16	.35 (.77)	.43 (.95)	.51 (1.13)	.57 (1.25)	0.70 (1.54)	.84 (1.84)	—	—	—	—	—	—	—	—
20	—	.76 (1.66)	.86 (1.90)	.94 (2.06)	1.11 (2.45)	1.29 (2.85)	1.47 (3.24)	—	—	—	—	—	—	—
25	—	1.13 (2.48)	—	1.39 (3.05)	1.65 (3.63)	1.91 (4.20)	2.17 (4.77)	2.43 (5.35)	—	—	—	—	—	—
32	—	1.67 (3.68)	—	2.07 (4.55)	2.46 (5.42)	2.86 (6.29)	3.26 (7.17)	3.65 (8.04)	4.05 (8.91)	4.45 (9.78)	—	—	—	—
40	—	2.00 (4.40)	—	2.42 (5.32)	2.84 (6.25)	3.26 (7.17)	3.68 (8.10)	4.10 (9.02)	4.52 (9.94)	4.94 (10.89)	5.36 (11.82)	5.78 (12.74)	—	—
50	—	2.63 (5.78)	—	3.22 (7.08)	3.81 (8.38)	4.40 (9.69)	4.99 (10.99)	5.59 (12.29)	6.18 (13.59)	6.77 (14.89)	7.36 (16.23)	7.95 (17.53)	—	—
63	—	3.29 (7.24)	—	3.98 (8.75)	4.66 (10.25)	5.34 (11.75)	6.02 (13.25)	6.71 (14.76)	7.39 (16.26)	8.07 (17.76)	8.75 (19.29)	9.43 (20.79)	10.11 (22.29)	10.79 (23.79)
80	—	6.06 (13.33)	—	7.12 (15.66)	8.18 (18.00)	9.24 (20.33)	10.30 (22.66)	11.36 (24.99)	12.42 (27.33)	13.48 (29.66)	14.54 (32.06)	15.60 (34.39)	16.66 (36.73)	17.72 (39.07)
100	—	10.69 (23.52)	—	12.03 (26.47)	13.37 (29.42)	14.71 (32.37)	16.05 (35.32)	17.39 (38.27)	18.73 (41.22)	20.08 (44.17)	21.42 (47.22)	22.76 (50.18)	24.1 (53.13)	25.44 (56.09)

**Units with Linear Ball Bushings**

Weights in kg (lb)

Model	Standard Stroke (mm)													
	10	25	40	50	75	100	125	150	175	200	250	300	350	400
16	0.32 (.70)	.39 (.86)	.46 (1.02)	.51 (1.13)	.64 (1.40)	.76 (1.67)	—	—	—	—	—	—	—	—
20	—	.70 (1.53)	.80 (1.75)	.86 (1.90)	1.03 (2.26)	1.19 (2.62)	1.36 (2.99)	—	—	—	—	—	—	—
25	—	.98 (2.15)	—	1.20 (2.64)	1.43 (3.14)	1.65 (3.64)	1.88 (4.14)	2.11 (4.63)	—	—	—	—	—	—
32	—	1.51 (3.31)	—	1.86 (4.09)	2.21 (4.86)	2.56 (5.63)	2.91 (6.41)	3.27 (7.18)	3.62 (7.96)	3.97 (8.73)	—	—	—	—
40	—	1.82 (4.01)	—	2.20 (4.83)	2.57 (5.66)	2.95 (6.49)	3.32 (7.31)	3.70 (8.14)	4.08 (8.97)	4.45 (9.79)	4.83 (10.65)	5.21 (11.49)	—	—
50	—	2.35 (5.17)	—	2.87 (6.32)	3.39 (7.47)	3.92 (8.62)	4.44 (9.76)	4.96 (10.91)	5.48 (12.06)	6.01 (13.21)	6.54 (14.42)	7.07 (15.59)	—	—
63	—	2.99 (6.58)	—	3.60 (7.93)	4.22 (9.28)	4.83 (10.63)	5.45 (11.98)	6.06 (13.33)	6.67 (14.68)	7.29 (16.03)	7.91 (17.44)	8.53 (18.81)	9.15 (20.17)	9.77 (21.54)
80	—	5.66 (12.45)	—	6.63 (14.59)	7.61 (16.74)	8.58 (18.88)	9.56 (21.03)	10.53 (23.18)	11.51 (25.32)	12.49 (27.47)	13.47 (29.70)	14.45 (31.86)	15.43 (34.02)	16.41 (36.18)
100	—	10.16 (22.36)	—	11.40 (25.09)	12.64 (27.82)	13.89 (30.55)	15.13 (33.28)	16.37 (36.01)	17.61 (38.74)	18.85 (41.46)	20.09 (44.29)	21.33 (47.02)	22.57 (49.76)	23.81 (52.49)

 Guided Cylinders  
 P5T Series  
 HB Series  
 P5E Series



For inventory, lead times, and kit lookup, visit [www.pdnplu.com](http://www.pdnplu.com)

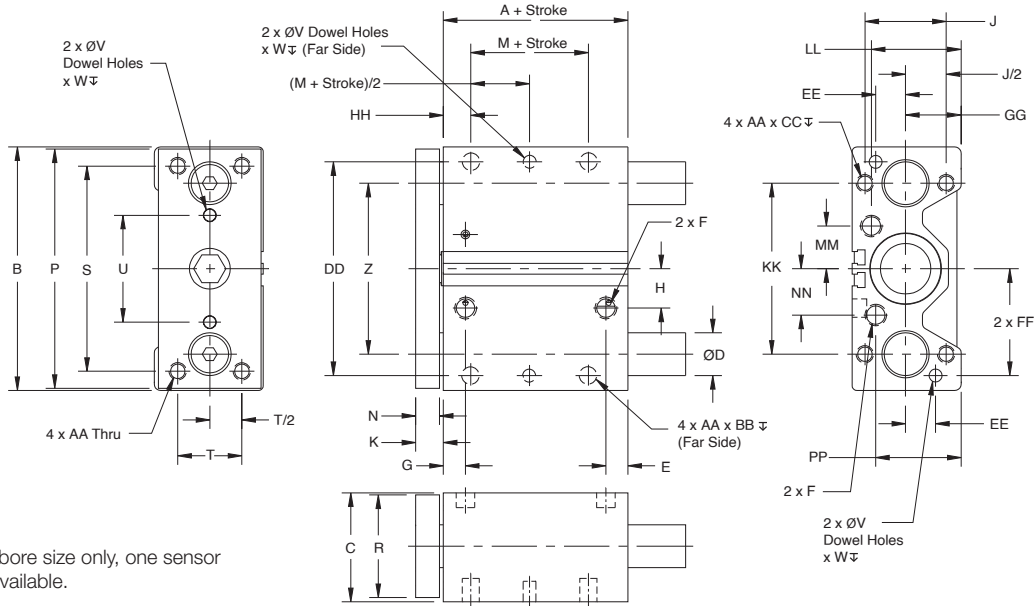

**Note:** On 16mm bore size only, one sensor groove is available.

Dimensions in mm (inch) **Note:** Dimensions for special stroke length actuators will be the same as those of the next longest stroke actuator.

Model	A**	Long Stroke Adder (>200 mm)	B	C	D	D <sup>2</sup>	E**	F	G	H	J	K
16	37.75	NA	64	31	8	10	10.1	M5/10-32	10.1	6.95	22	9.94
20	36	NA	74	36	10	12	19	1/8 NPTF or BSPP	10	15.8	26	9.94
25	38	NA	88	42	12	16	21	1/8 NPTF or BSPP	11.4	15.5	32	9.94
32	36	NA	114	51	16	20	10.26	1/8 NPTF or BSPP	10.35	18.42	38	13.1
40	44	14.4	124	52	16	20	12.10	1/8 NPTF or BSPP	14.9	22.53	38	13.1
50	44.9	12.4	140	62	20	25	14.5	1/4 NPTF or BSPP	16.1	27	44	14.7
63	50.05	8.9	150	75	20	25	16.4	1/4 NPTF or BSPP	14.5	33	44	14.7
80	60.3	14.4	188	95	25	30	17.5	3/8 NPTF or BSPP	19	37	56	18
100**	67.5	9.3	224	115	30	35	21.9	3/8 NPTF or BSPP	23	40	62	18

Model	M	N	P	R	S	T	U	V	W	Z	AA	BB
16	7	7.94	62	25.4	52	16	20	3	6	42	M5x0.8	7.5
20	10	7.94	72	31.8	60	18	30	4	6	52	M5x0.8	7.5
25	10	7.94	86	38	70	26	34	4	6	62	M6x1.0	9
32	5	11.1	112	44.5	96	30	50	6	6	80	M8x1.25	11
40	10	11.1	122	44.5	106	30	60	6	6	90	M8x1.25	11
50	10	12.7	138	57.2	120	40	60	8	8	100	M10x1.5	12
63	10	12.7	148	69.9	130	50	72	8	8	110	M10x1.5	15
80	15	16	185	89	160	60	92	10	10	140	M12x1.75	18
100	15	16	221	108	190	80	114	10	10	170	M14x2.0	21

Model	CC	DD	EE	FF	GG	HH	KK	LL	MM	NN	PP	Piston Rod
16	10	54	8	27	15	13.06	42 (1.654)	22.5	11.25	9.7	23.0	8
20	10	64	10	32	17	13.06	52 (2.126)	26.0	15.4	15.4	26.0	10
25	12	76	11	38	21	14.06	62 (2.441)	33.4	17	17	33.4	10
32	16	100	14	50	26	12.9	80 (3.150)	42	20	21.7	38	16
40	16	110	14	55	26	13.9	90 (3.543)	41	24	26.4	37.9	16
50	20	124	16	62	30	14.3	100 (3.937)	51	29	33	44	20
63	20	132	18	66	36.5	16.3	110 (4.331)	62	36	37.75	57.75	20
80	24	166	22	83	46.5	21	140 (5.512)	78	45	48	75.5	25
100	28	200	24	100	56.5	25	170 (6.693)	91.5	53	51	95.5	25

D<sup>1</sup> With linear ball bearing      D<sup>2</sup> With composite bushing  
 \*\* For Model 100 with 25mm stroke, A = 100.3 (3.95") and E = 28 (1.10")



For inventory, lead times, and kit lookup, visit [www.pdnplu.com](http://www.pdnplu.com)



**Shaft Bearings**

Composite bushings are supplied as standard.  
Linear ball bearings are optional.

Selection should be based on the following criteria:

Application Requirement	Ball	Composite
Precision	Excellent	Good
Friction	Low	Higher
Friction Coefficient	Constant	Variable
Precision Over Life Of Bearing	Constant	Variable
Static Load Capacity	Good	Excellent
Dynamic Load Capacity	Good	Good With Lower Efficiency
Vibration Resistance	Fair	Excellent
Contamination Resistance	Poor	Excellent
Washdown Compatibility	Poor	Excellent

For bearing load capacities, reference the Engineering Data section.

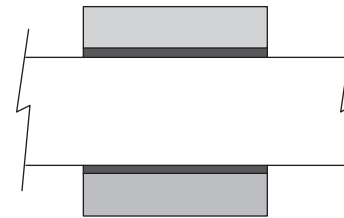

**Composite Bushing (J,C)**

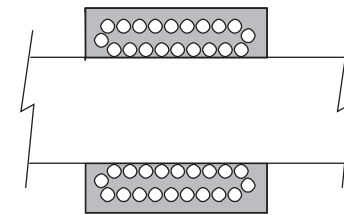

**Recirculating Ball Bearing (H)**

**Corrosion Resistant Shafting (C, H)**

Chrome-plated case hardened, high carbon alloy steel shafting with composite bearings is utilized for standard slides. This may corrode in some applications. Stainless steel corrosion resistant shafting is available.

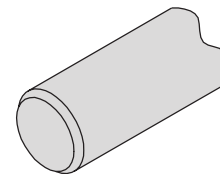

**Side Porting (S)**

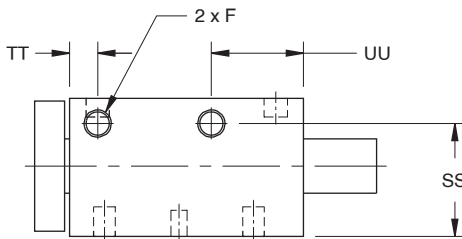

**NOTES:**

1. Side ports not available on 100mm bore units with 25mm of stroke.
2. Cannot use flow controls with 25mm stroke on any bore size.

Model	SS mm (in)	TT mm (in)	UU mm (in)	F
16	24.1 (.95)	10 (.39)	20 (.79)	10-32 or M5
20	29.00 (1.15)	10 (.39)	20 (.79)	10-32 or M5
25	35.15 (1.38)	11.4 (.45)	24 (.94)	10-32 or M5
32	43.2 (1.70)	10.35 (.41)	34 (1.34)	1/8 NPTF or BSPP
40	43.0 (1.69)	14.9 (.59)	34 (1.34)	1/8 NPTF or BSPP
50	51.25 (2.02)	16.1 (.64)	38 (1.50)	1/4 NPTF or BSPP
63	60.70 (2.39)	15.55 (.61)	41.8 (1.65)	1/4 NPTF or BSPP
80	75.5 (2.97)	19 (.75)	47 (1.85)	3/8 NPTF or BSPP
100	83.7 (3.30)	23 (.91)	53.3 (2.10)	3/8 NPTF or BSPP

**U**  
 Guided  
 Cylinders  
 P5T  
 Series  
 HB  
 Series  
 P5E  
 Series



For inventory, lead times, and kit lookup, visit [www.pdnplu.com](http://www.pdnplu.com)



**Flow Controls (B, F, N, P)**

Right angle flow control valves allow precise adjustment of cylinder speed by metering exhaust air flow. Prestolok push-in or threaded ports provide 360° orientation capability.

Model	A (in)	B (in)	C (in)	Imperial	
				Prestolok (F)	NPT (N)
16, 20*, 25*	0.87	0.96	0.39	5/32"	10-32
20, 25, 32, 40	1.63	1.38	0.67	5/32"	1/8
50, 63	1.86	1.64	0.91	1/4"	1/4
80, 100	2.15	1.90	1.06	3/8"	3/8

Model	A (mm)	B (mm)	C (mm)	Metric	
				Prestolok (P)	BSPP (B)
16, 20*, 25*	22.0	24.5	10.0	4mm	M5
20, 25, 32, 40	34.5	31.6	14.4	6mm	1/8
50	41.0	34.9	18.4	6mm	1/4
63	41.0	41.3	18.4	10mm	1/4
80	51.0	46.7	21.6	10mm	3/8
100	51.0	46.7	21.6	12mm	3/8

\* Side ports only.

**Note:** When flow controls are specified with rear ports, a 90° right angle fitting is supplied to provide ample rod clearance in the rear.

Prestolok flow controls are not available on 32-100mm bore sizes with 25mm of stroke.

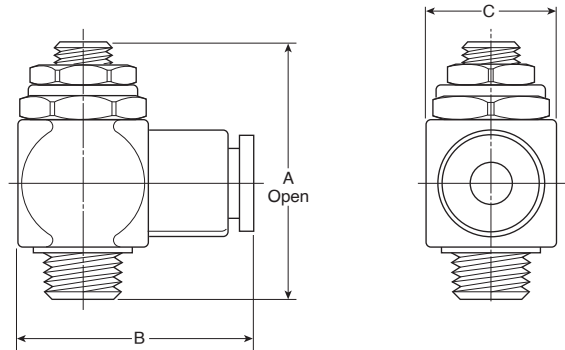

**Fluorocarbon Seals (F)**

Standard abrasion resistant nitrile seals should be used for general purpose applications with temperatures of -18 to 74°C (0 to 165°F). Fluorocarbon seals are recommended for high temperature applications up to 121°C (250°F).

Feature	Temperature Range
Bumpers	-18 to 93°C (0 to 200°F)
Magnets	-18 to 74°C (0 to 165°F)
Sensors	-10 to 85°C (14 to 185°F)



Guided  
Cylinders

P5T  
Series

HB  
Series

P5E  
Series



Standard Length – No Options (N)

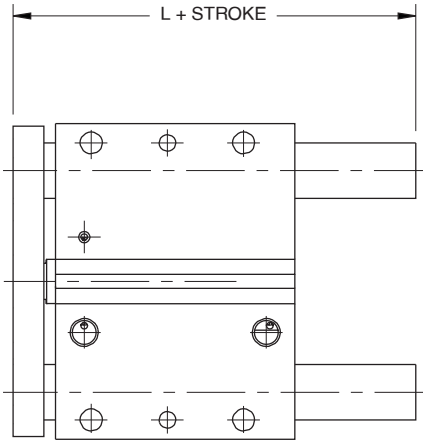

Model	Stroke (mm)	L	
		mm	inch
16	10*, 25, 40, 50, 75	60.2	2.37
	100	75.2	2.96
20	25, 40, 50, 75	66.9	2.63
	100, 125	91.9	3.62
25	25, 50, 75	69.9	2.75
	100, 125, 150	91.9	3.62
32	25, 50, 75, 100	77.9	3.07
	125, 150, 175, 200	116.0	4.57
40	25, 50, 75, 100	77.9	3.07
	125, 150, 175, 200, 250, 300	116.0	4.57
50	25, 50, 75, 100	84.0	3.31
	125, 150, 175, 200	124.1	4.89
	250, 300	168.7	6.64
63	25, 50, 75, 100	84.0	3.31
	125, 150, 175, 200	124.1	4.89
	250, 300, 350, 400	168.7	6.64
80	25, 50, 75, 100	101.8	4.00
	125, 150, 175, 200	140.0	5.51
	250, 300, 350, 400	195.0	7.68
100	25**, 50, 75, 100	120.3	4.74
	125, 150, 175, 200	158.4	6.24
	250, 300, 350, 400	195.0	7.68

\* For Model 16 with 10mm stroke, L = 37.7mm (1.48").

\*\* For Model 100 with 25mm stroke, L = 122.8mm (4.8").

High Load Bearings (B)

The standard bearing configuration locates both sets of bearings at the tooling plate end of the actuator providing a compact actuator package. The high load bearings option (B) locates the bearings at the extreme ends of the housing, increasing the dynamic and static load capacity. The bearing centerlines increase as stroke length increases.

**Note:** Rear mounting and ports are not available with the high load bearing option.

Standard Bearings

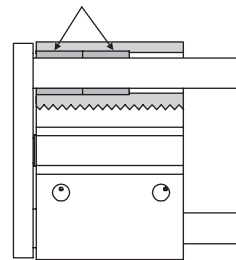

High Load Bearings

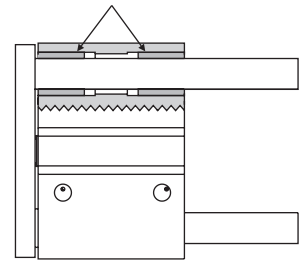

Model	X		LX
	mm	inch	
16	49.7	1.955	
20	47.0	1.849	
25	49.9	1.963	
32	51.1	2.012	
40	59.1	73.5	2.327
50	61.6	74.0	2.425
63	66.8	75.7	2.630
80	79.6	94.0	3.135
100	86.1	95.5	3.391

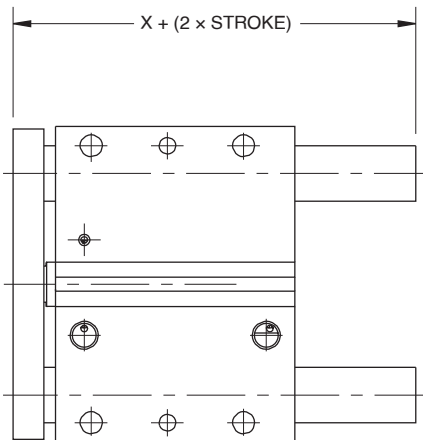

Dual Tool Plate (D)

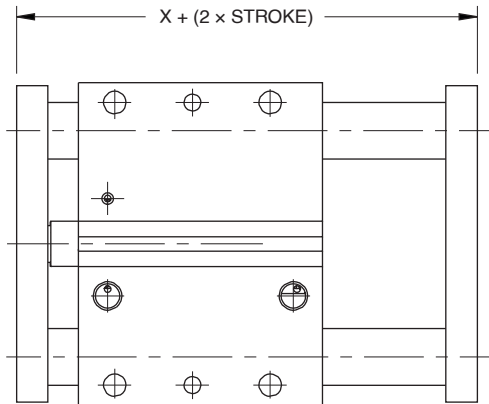

Bumpers, Stop Collars & Dual Tool Plate (A)

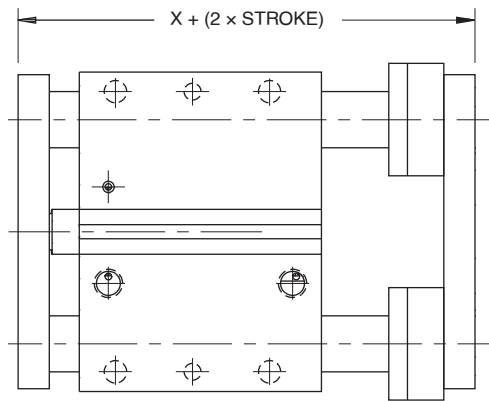

Bumpers & Adjustable Stop Collars, Extend Only (E)

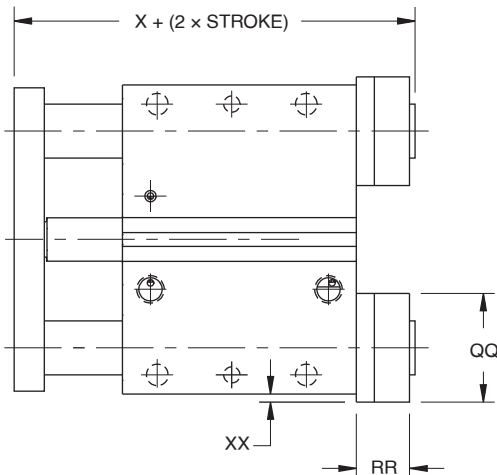

Notes:

1. Load capacities increase on dual tool plate (D & A). For load capacities, use the high load bearing graphs.
2. Rear mounting holes and rear ports are not available with Options D, A, and E.

Rod Model	X									
	D Option	L	A Option	L	E Option	L	QQ	RR	XX	
16	8	57.7 (2.27)		70.7 (2.78)		62.7 (2.47)	18.0 (0.71)	15.7 (0.62)	0	
	10	57.7 (2.27)		70.7 (2.78)		62.7 (2.47)	24.0 (0.95)	15.7 (0.62)	1 (0.04)	
20	10	54.7 (2.15)		67.9 (2.67)		59.9 (2.36)	24.0 (0.95)	15.7 (0.62)	1 (0.04)	
	12	54.7 (2.15)		72.6 (2.86)		64.6 (2.54)	28.0 (1.10)	17.7 (0.70)	3 (0.12)	
25	12	58.8 (2.31)		76.5 (3.01)		68.1 (2.68)	28.0 (1.10)	17.7 (0.70)	1 (0.04)	
	16	58.8 (2.31)		78.5 (3.09)		70.1 (2.76)	34.0 (1.34)	19.7 (0.78)	4 (0.16)	
32	16	62.2 (2.45)		81.9 (3.22)		70.8 (2.79)	34.0 (1.34)	19.7 (0.78)	0	
	20	62.2 (2.45)		83.9 (3.30)		72.8 (2.87)	40.0 (1.57)	21.7 (0.85)	3.7 (0.15)	
40	16	70.2 (2.76)	84.6	89.9 (3.54)	104.3	78.8 (3.10)	93.2	34.0 (1.34)	19.7 (0.78)	0
	20	70.2 (2.76)	84.6	91.9 (3.62)	106.3	80.8 (3.18)	95.2	41.4 (1.63)	21.7 (0.85)	3.7 (0.15)
50	20	74.3 (2.93)	84.7	96.0 (3.78)	108.4	83.3 (3.28)	95.7	41.4 (1.63)	21.7 (0.85)	0.7 (0.03)
	25	74.3 (2.93)	84.7	96.0 (3.78)	108.4	83.3 (3.28)	95.7	45.0 (1.77)	21.7 (0.85)	5.4 (0.21)
63	20	79.5 (3.13)	88.4	101.2 (3.98)	110.1	88.5 (3.48)	97.4	41.4 (1.63)	21.7 (0.85)	0.7 (0.03)
	25	79.5 (3.13)	88.4	101.2 (3.98)	110.1	88.5 (3.48)	97.4	50.8 (2.00)	21.7 (0.85)	5.4 (0.21)
80	25	96.1 (3.78)	110.5	117.8 (4.64)	132.2	101.9 (4.01)	116.3	50.8 (2.00)	21.7 (0.85)	1.4 (0.06)
	30	96.1 (3.78)	110.5	117.8 (4.64)	132.2	101.9 (4.01)	116.3	54.0 (2.13)	21.7 (0.85)	6.3 (0.25)
100	30	103.3 (4.07)	112.6	125.8 (4.95)	135.1	109.1 (4.30)	118.4	60.5 (2.38)	21.7 (0.85)	3.3 (0.13)
	35	103.3 (4.07)	112.6	125.8 (4.95)	135.1	109.1 (4.30)	118.4	57.0 (2.24)	21.7 (0.85)	5.5 (0.22)

All dimensions in mm (inch)



Guided  
Cylinders

P5T  
Series

HB  
Series

P5E  
Series



Options

Contaminant & Weld Flash Covers

A contaminant cover protects the guide rods and bearings from particles and fluid that could cause premature failure.

A weld flash cover protects guide rods and bearings from weld spatter.

Cover option can be ordered on models having the bearings both ends option.

Consult factory to order.

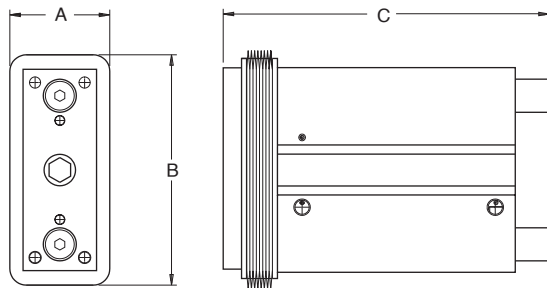

Weld Flash Cover Specifications

Coating Material (Exposed Side)	Pvc (Black)
Base Material	Nomex
Coating Material (Other Side)	Pvc (Black)
Material Thickness Range	.012" - .016" (.3-.4mm)
Temperature Resistance (Nomex)	
Briefly	642°F (450°C)
Continuously	-22° To 572°F (-30° To 300°C)
Temperature Resistance (Coating)	
Briefly	392°F (200°C)
Continuously	-22° To 302°F (-30° To 150°C)
Resistant To	Chemicals, Coolants, Solvents, Oil
Characteristics	Self-Extinguishing, Abrasion Resistant
Material Weight	400 Grams/Square Meter

 Guided Cylinders  
 P5T Series  
 HB Series  
 P5E Series

Model	A	B	Standard Stroke									
			10	25	40	50	75	100	125	150	175	200
16	42 (1.65)	86 (3.39)	61.2 (2.41)	100.2 (3.94)	135.2 (5.32)	135.2 (5.32)	160.2 (6.31)	200.2 (7.88)	-	-	-	-
20	45 (1.77)	98 (3.86)	-	106.9 (4.21)	141.9 (5.59)	141.9 (5.59)	166.9 (6.57)	216.9 (8.54)	241.9 (9.52)	-	-	-
25	49 (1.93)	112 (4.41)	-	119.9 (4.72)	-	144.9 (5.70)	169.9 (6.69)	194.9 (7.67)	241.9 (9.52)	266.9 (10.51)	-	-
32	62 (2.44)	142 (5.59)	-	127.9 (5.04)	-	152.9 (6.02)	177.9 (7.00)	202.9 (7.99)	266 (10.47)	291 (11.46)	316 (12.44)	341 (13.43)
40	62 (2.44)	152 (5.98)	-	127.9 (5.04)	-	152.9 (6.02)	177.9 (7.00)	202.9 (7.99)	266 (10.47)	291 (11.46)	316 (12.44)	341 (13.43)
50	66 (2.60)	167 (6.57)	-	134 (5.28)	-	159 (6.26)	184 (7.24)	209 (8.23)	274.1 (10.79)	299.1 (11.78)	324.1 (12.76)	349.1 (13.74)
63	77 (3.03)	187 (7.36)	-	134 (5.28)	-	159 (6.26)	184 (7.24)	209 (8.23)	274.1 (10.79)	299.1 (11.78)	324.1 (12.76)	349.1 (13.74)
80	104 (4.09)	244 (9.61)	-	151.8 (5.98)	-	176.8 (6.96)	201.8 (7.94)	226.8 (8.93)	290 (11.42)	315 (12.40)	340 (13.39)	365 (14.37)
100	109 (4.29)	279 (10.98)	-	170.3 (6.70)	-	195.3 (7.69)	220.3 (8.67)	245.3 (9.66)	308.4 (12.14)	333.4 (13.13)	358.4 (14.11)	383.4 (15.09)

All dimensions in mm (inch)



For inventory, lead times, and kit lookup, visit [www.pdnplu.com](http://www.pdnplu.com)

**Options**

**P8S Electronic and Reed Sensors**

The P8S Series magnetic cylinder sensor enables quick, precise and contactless sensing of the piston's position in cylinders. It is easy to mount, can be used in numerous applications and offers an outstanding price-performance ratio.

Magnetic piston is standard.

See Electronic Sensors section for part numbers and specifications.

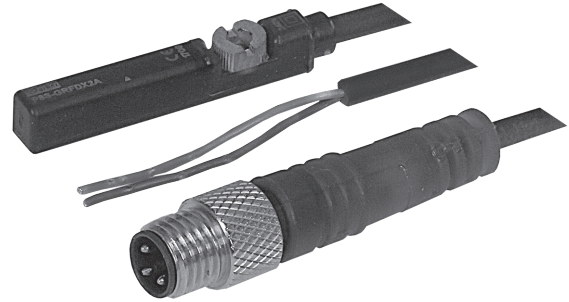

**Seal Kits**

Bore Size	Seal Kit Part Number	
	Nitrile Seals	Fluorocarbon Seals
16	PSK-P5T16	PSK-P5T16-F
20	PSK-P5T20	PSK-P5T20-F
25	PSK-P5T25	PSK-P5T25-F
32	PSK-P5T32	PSK-P5T32-F
40	PSK-P5T40	PSK-P5T40-F
50	PSK-P5T50	PSK-P5T50-F
63	PSK-P5T63	PSK-P5T63-F
80	PSK-P5T80	PSK-P5T80-F
100	PSK-P5T100	PSK-P5T100-F



Guided  
Cylinders

P5T  
Series

HB  
Series

P5E  
Series



Features

HB Series

Model HBT Shown

**TOOLING PLATE**  
Precision machined from aluminum and then anodized, the tooling plate allows mounting on two sides. Standard dowel pin holes provide accurate mounting.

**BODY**  
A machined aluminum one-piece anodized body with tapped and counterbored through holes on three faces for mounting flexibility. Standard dowel pin holes provide accurate mounting.

**CYLINDER PISTON**  
Aluminum piston with nylon wearband eliminates metal-to-metal contact. This increases cylinder life especially when the support shafts deflect under load. Magnetic piston is standard on all HB slides.

**CYLINDER BODY**  
Extruded aluminum profile cylinder body offers integrated sensor grooves to minimize sensor installation time, maximize sensor protection and eliminate the need for brackets. Grooves readily accept both Global and Mini-Global Sensors. Single corner lobe of extrusion will accept legacy 2MA sensor brackets. Anodized and bright-dipped for corrosion resistance, maximum seal life and lower friction.

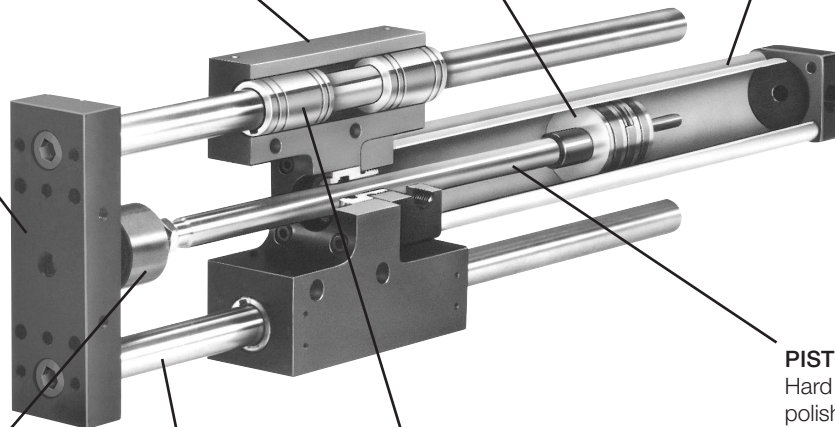

**ALIGNMENT COUPLER**  
For long stroke or heavy load applications, the alignment coupler allows the piston rod to self-center, thus increasing cylinder life. Not available for HBC Series due to shorter strokes.

**SUPPORT SHAFTS**  
Case hardened to Rc 60 - 65, support shafts are machined from high carbon alloy steel and chrome plated. Stainless steel and oversized shafting are available.

**BUSHINGS**  
Composite bushings with oversized shafting are available for higher loads and lower cost. Sealed recirculating ball bearings provide precise alignment with very low friction and wear.

**PISTON ROD**  
Hard chrome plated and polished piston rod of 100,000 PSI yield, high tensile strength steel, case hardened to Rc 50-54 for reliable performance, reduced friction and long rod seal life.

	Guided Cylinders
P5T Series	
HB Series	
P5E Series	

Features

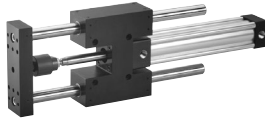

- Medium duty to extremely heavy duty linear motion
- Powered by the 4MA NFPA cylinder, with ISO options available
- Bore sizes 3/4", 1", 1-1/4", 1-1/2", 2", and 2-1/2"
- Thrust, reach, and compact versions available
- Shock absorber, bumpers/stop collars, and proximity sensor options available

Operating information

Maximum Operating pressure: 100 PSIG (7 bar), air – 4MAJ cylinder  
 145 PSIG (10 bar), air – P1F cylinder  
 250 PSIG (17 bar), air – 4MA, SR and 2A cylinders  
 400 PSIG (28 bar), oil – 4ML cylinder only  
 750 PSIG (52 bar), oil – 3L cylinder only

Cylinder Temperature range: Standard seals 0°F to 165°F (-18°C to 74°C)  
 Fluorocarbon seals\* 0°F to 250°F (-18°C to 121°C)  
 \* See fluorocarbon seal option for high temperature applications.

Filtration requirements: 40 micron, dry filtered air

Ordering information

**HBT 25 - 08 A P1 T K 4A - B**

Series	
HBC	Compact Slide
HBT	Thrust Slide
HBR	Reach Slide

**Stroke length**  
 Can Order in 10th of an Inch Increments<sup>4</sup>  
 For 3-Position Units, Specify Intermediate and Total Stroke Separated by a “/”, i.e. 2.5/6.5  
 Consult Factory for Strokes Over 36"

Bushings	
T	Composite (standard)
D	Linear Ball Bearing
T1	Composite with Oversized Support Shafts
TC	Composite with Contaminant-Tolerant Seals

Design Series	
B	Current Design Level

Special Options	
Blank	Standard
(Two digit code assigned by factory and applies when any “X” appears in the model number or when special options or features are required.)	

Cylinder Options	
(More than one selection is possible)	
Blank	None
V	Fluorocarbon Cylinder Seals <sup>3</sup>

Model	
07	3/4" (20 mm) Bore, 10mm Shaft <sup>6,9</sup>
10	1" (25 mm) Bore, 12mm Shaft <sup>6,9</sup>
12	1-1/4" (32 mm) Bore, 16mm Shaft <sup>7,9</sup>
15	1-1/2" (40 mm) Bore, 20mm Shaft <sup>8</sup>
20	2" (50 mm) Bore, 25mm Shaft <sup>8</sup>
25	2-1/2" (63 mm) Bore, 30mm Shaft <sup>8</sup>

Proximity Sensor Options	
Blank	None
P	PNP, Flying Lead Type
P1	PNP, Plug-In Connector
J	8mm Sensor Mounting Bracket, No Sensor Supplied
J1	12mm Sensor Mounting Bracket, No Sensor Supplied

Note: 8mm inductive proximity sensors are included with options P, P1. Magnetic piston is standard for 4MA, 4MAJ, 4ML, P1F, SR cylinders. Order reed and solid state sensors separately.

Slide Configuration Options	
Blank	None
A	Shock Absorber, Both Ends
A1	Shock Absorber, Extend Only
B	Bumper & Adjustable Stop Collar, Extend, Bumper Retract
B1	Bumper & Adjustable Stop Collar, Extend Only
B4	Bumper & Adjustable Stop Collar, Both Ends
X	Special Slide Configuration (please specify)

Other Options	
Blank	None
K	Stainless Steel Support Shafting

Cylinder Type	
4A	4MA NFPA Air Cylinder, NPTF Ports
4J	4MAJ NFPA Air Cylinder with Manual Override Rodlock, NPTF Ports, 100 PSIG Max.
4L	4ML NFPA Hydraulic Cylinder, NPTF Ports, 400 PSIG Max. <sup>2,5</sup>
F	P1F ISO Cylinder, BSPP Ports <sup>7</sup>
F1	P1F ISO Cylinder, Standard Rodlock, BSPP Ports <sup>7</sup>
SR	SRM Series Cylinder, NPTF Ports <sup>6,7,8,9</sup>
S	2A NFPA Steel Air Cylinder, 250 PSIG Max.
S1	3L NFPA Steel Hydraulic Cylinder, 750 PSIG Max. (Stop Collars, Bumpers, and Flow Controls Not Available with This Option.) <sup>5</sup>
Q	No Cylinder, NFPA Cylinder Mounting
Q1	No Cylinder, ISO Cylinder Mounting
X	Special Cylinder Type (please specify)

Note: All cylinders to have cushions both ends, except for 4L and 3L options.

**NOTES**

<sup>2</sup> Cushions are N/A with 4ML cylinder type.  
<sup>3</sup> Fluorocarbon seals N/A with rodlock cylinder type.  
<sup>4</sup> P1F cylinders have strokes only in whole mm. The HB inch stroke will be changed (rounded up) to reflect this.  
<sup>5</sup> No bumpers or stop collars with 4ML/3L cylinder types.  
<sup>6</sup> Model 07, 10 only available with SR cylinder type.  
<sup>7</sup> Model 12 only available with SR/P1F cylinder types.  
<sup>8</sup> SRM cylinder type N/A on models 15, 20, 25.  
<sup>9</sup> Model 07, 10, 12 only available with HBT thrust slide.

**Sensors**  
See section L for sensors.

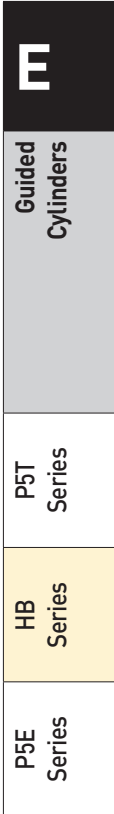

For inventory, lead times, and kit lookup, visit [www.pdnplu.com](http://www.pdnplu.com)

**General Specifications**

**Specifications**

- Maximum operating pressure: 100 psi (air) – 4MAJ cylinder  
145 psi (air) – P1F cylinder  
250 psi (air) – 4MA, SR and 2A cylinders  
400 psi (oil) – 4ML cylinder only  
750 psi (oil) – 3L cylinder only
- Operating characteristics: double acting
- Support shaft sizes: 10,12,16, 20, 25, 30 and 35 mm
- Stroke tolerance: +.030, -.000
- Mounting: unrestricted
- Operating temperature range (cylinder): Standard seals 0 to 165°F  
Fluorocarbon seals\* 0 to 250°F
- Filtration requirement: 40 micron filtered, dry air or filtered hydraulic oil (4ML or 3L)

\* See fluorocarbon seal option for high temperature applications. Not available for rod lock cylinders.

Online sizing: <http://solutions.parker.com/virtualEngineer>

**Quick Reference Data**

Bore	Standard Support Rod Diameter		Oversized Support Rod Diameter		Output Force on Extension @5.5 Bar (80 psi)		Output Force on Retract @5.5 Bar (80 psi)		Maximum Suggested Stroke**	
	mm	(in)	mm	in	N	lbs	N	lbs	mm	in
07	10	0.39	12	0.47	173	39	147	33	400	16
10	12	0.47	16	0.63	271	61	227	51	400	16
12	16	0.63	20	0.79	445	100	383	86	450	18

Model	Weights, Standard Shaft (Lb)	
	Base Unit	
	HBT	Per Inch Stroke
07	1.26	0.10
10	2.63	0.18
12	4.37	0.27

Model	Support Shaft Diameter mm (in)	Oversized Shaft Diameter mm (in)	4MA, 4MAJ, 4ML NFPA Cylinder Bore Size (in)	P1F ISO Cylinder Bore Size (mm)	Force Output on Extend at 80 PSI (lb)	Force Output on Retract at 80 PSI (lb)
15	20 (0.79)	25 (0.98)	1½	40	142	117
20	25 (0.98)	30 (1.18)	2	50	251	226
25	30 (1.18)	35 (1.38)	2½	63	393	368

Model	Maximum Suggested Stroke, Inches*			Weights, Standard Shaft (Lb)				Weights, Oversized Shaft (Lb)			
	HBC	HBT	HBR	Base Unit			Per Inch Stroke	Base Unit			Per Inch Stroke
				HBC	HBT	HBR		HBC	HBT	HBR	
15	8	24	30	6.54	8.86	12.76	0.48	7.24	9.83	14.20	0.63
20	10	30	36	11.57	14.35	24.02	0.64	12.60	15.67	26.19	0.83
25	12	36	42	20.57	24.45	42.03	0.85	22.03	25.69	44.50	1.08

\*Consult factory for longer strokes.



For inventory, lead times, and kit lookup, visit [www.pdnplu.com](http://www.pdnplu.com)



**HBC Series: 15, 20, 25**

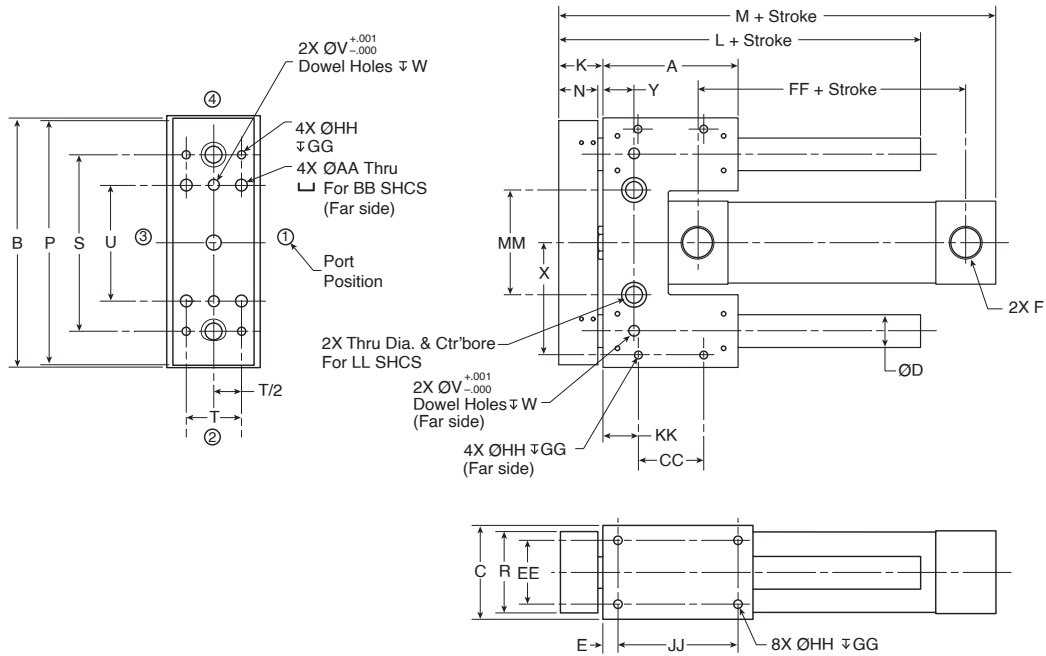

Model	A	B	C	Ds*	Do**	E	F NPTF	F BSPP	K	L	M	N	P	R	S	T	U
HBC15	3.25	6.00	2.25	20mm (0.79)	25mm (0.98)	0.375	1/4 <sup>1</sup>	1/4	1.06	5.19	6.26	0.94	5.88	1.94	4.250	1.375	2.750
HBC20	4.00	7.25	2.75	25mm (0.98)	30mm (1.18)	0.500	3/8	1/4	1.31	6.39	7.00	1.19	7.13	2.44	5.000	1.750	3.250
HBC25	5.00	9.00	3.25	30mm (1.18)	35mm (1.38)	0.500	3/8	3/8	1.56	7.82	8.38	1.44	8.88	2.88	6.500	2.000	3.750

Model	V	W	X	Y	AA	BB	CC	EE	FF	GG	HH	JJ	KK	LL	MM
HBC15	0.251	0.27	2.750	0.750	0.28	1/4	1.750	1.500	2.31	0.50	1/4-20	2.50	0.75	3/8	2.500
HBC20	0.313	0.33	3.250	0.750	0.34	5/16	2.250	1.750	2.31	0.63	5/16-18	3.00	0.88	3/8	3.000
HBC25	0.376	0.39	4.000	1.532	0.41	3/8	3.000	2.250	2.38	0.75	3/8-16	4.00	1.00	1/2	4.000

\* Standard shafting  
\*\* Oversized shafting

All dimensions in inches unless otherwise noted.

**P**

Guided  
Cylinders

P5T  
Series

HB  
Series

P5E  
Series



For inventory, lead times, and kit lookup, visit [www.pdnplu.com](http://www.pdnplu.com)

Dimensional Data

HBT Series: 07, 10, 12

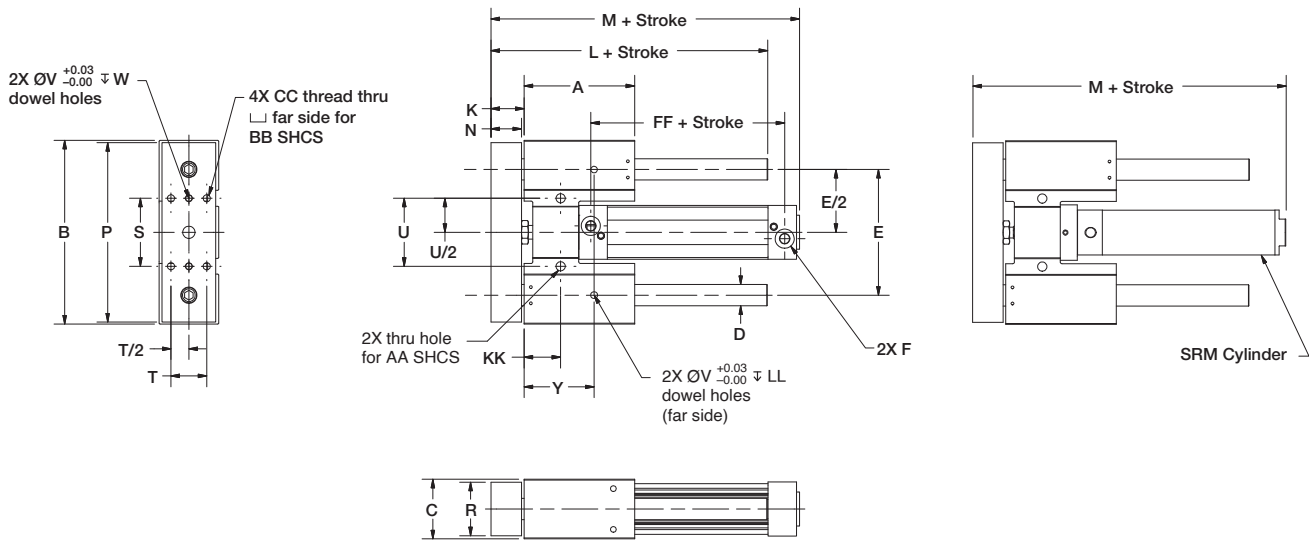

Model	A	B	C	Ds	Do	E	F (P1F)	F (SRM)	K	L	M (P1F)	M (SRM)	N	P
HBT07	2.4 (60)	3.9 (98)	1.2 (30)	0.4 (10)	12 (12)	2.7 (68)	N/A	1/8 NPT	0.8 (20)	3.4 (86)	N/A	4.4 (112)	0.7 (17)	3.8 (96)
HBT10	3.0 (76)	4.8 (122)	1.5 (38)	0.5 (12)	0.6 (16)	3.3 (84)	N/A	1/8 NPT	1.0 (25)	4.2 (107)	N/A	5.0 (126)	0.9 (22)	4.7 (119)
HBT12	3.3 (84)	5.5 (140)	1.9 (47)	0.6 (16)	0.8 (20)	3.6 (92)	G1/8 1/8 NPT	1/8 NPT	1.1 (27)	4.6 (117)	7.2 (184)	4.9 (124)	0.9 (24)	5.4 (137)

Model	R	S	T	U	V	W	Y	AA	BB	CC	FF (P1F)	KK	LL
HBT07	1.0 (26)	1.6 (40)	0.6 (16)	1.6 (40)	0.16 (4.03)	0.16 (4)	1.4 (36)	M5	M4	M5X0.8	N/A	0.6 (16)	0.16 (4)
HBT10	1.3 (33)	1.9 (48)	0.8 (20)	1.9 (48)	0.19 (5.03)	0.19 (5)	1.8 (46)	M6	M5	M6X1.0	N/A	0.9 (22)	0.19 (5)
HBT12	1.5 (39)	2.0 (50)	0.9 (24)	2.0 (50)	0.24 (6.03)	0.24 (6)	2.1 (53)	M8	M6	M8X1.25	2.7 (68)	1.1 (28)	0.24 (6)

Dimensions in inches (mm).

  
 Guided Cylinders  
 P5T Series  
 HB Series  
 P5E Series



For inventory, lead times, and kit lookup, visit [www.pdnplu.com](http://www.pdnplu.com)

**HBT Series: 15, 20, 25**

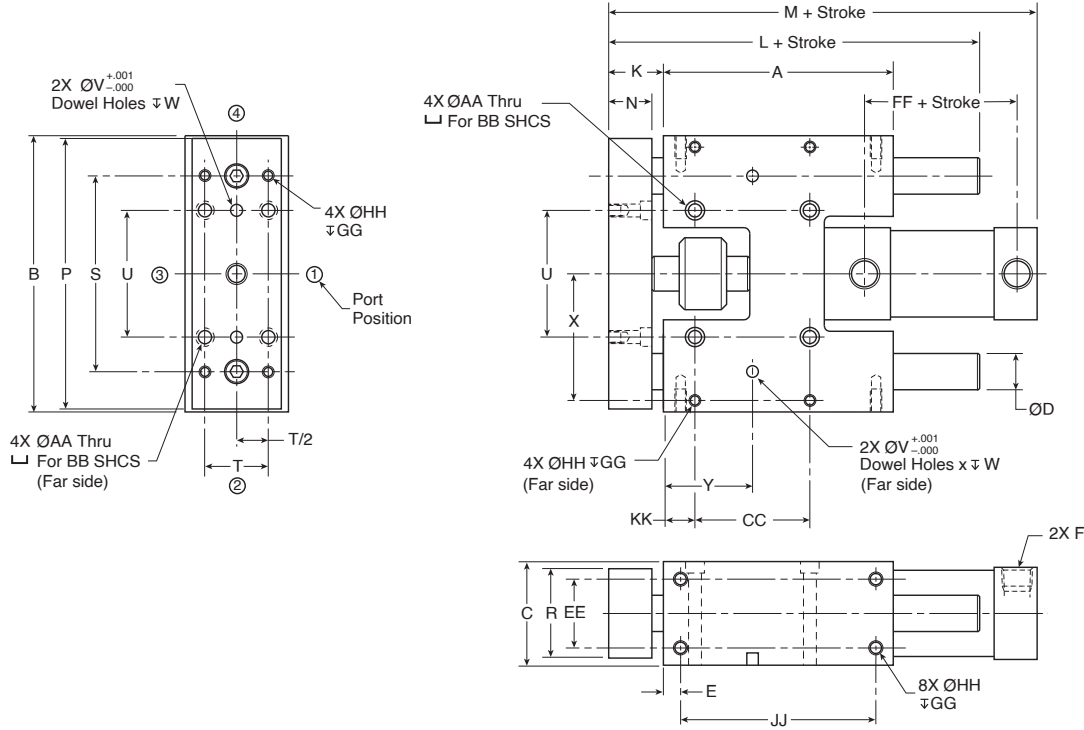

Model	A	B	C	Ds*	Do**	E	F NPTF	F BSPP	K	L	M	N	P	R	S	T
HBT15	5.0	6.00	2.25	20mm (0.79)	25mm (0.98)	0.375	1/4	1/4	1.06	6.94	8.19	0.94	5.88	1.94	4.250	1.375
HBT20	5.5	7.25	2.75	25mm (0.98)	30mm (1.18)	0.500	3/8	1/4	1.31	7.88	8.94	1.19	7.13	2.44	5.000	1.750
HBT25	6.5	9.00	3.25	30mm (1.18)	35mm (1.38)	0.500	3/8	3/8	1.56	9.31	10.31	1.44	8.88	2.88	6.500	2.000

Model	U	V	W	X	Y	AA	BB	CC	EE	FF	GG	HH	JJ	KK
HBT15	2.750	0.251	0.27	2.750	1.938	0.28	1/4	2.500	1.500	2.31	0.50	1/4-20	4.25	0.69
HBT20	3.250	0.313	0.33	3.250	2.250	0.34	5/16	2.750	1.750	2.31	0.63	5/16-18	4.50	0.88
HBT25	3.750	0.376	0.39	4.000	2.750	0.41	3/8	3.500	2.250	2.38	0.75	3/8-16	5.50	1.00

\* Standard shafting  
 \*\* Oversized shafting

All dimensions in inches unless otherwise noted.

**P**

Guided Cylinders

P5T Series

HB Series

P5E Series



For inventory, lead times, and kit lookup, visit [www.pdnplu.com](http://www.pdnplu.com)

Dimensional Data

HBR Series: 15, 20, 25

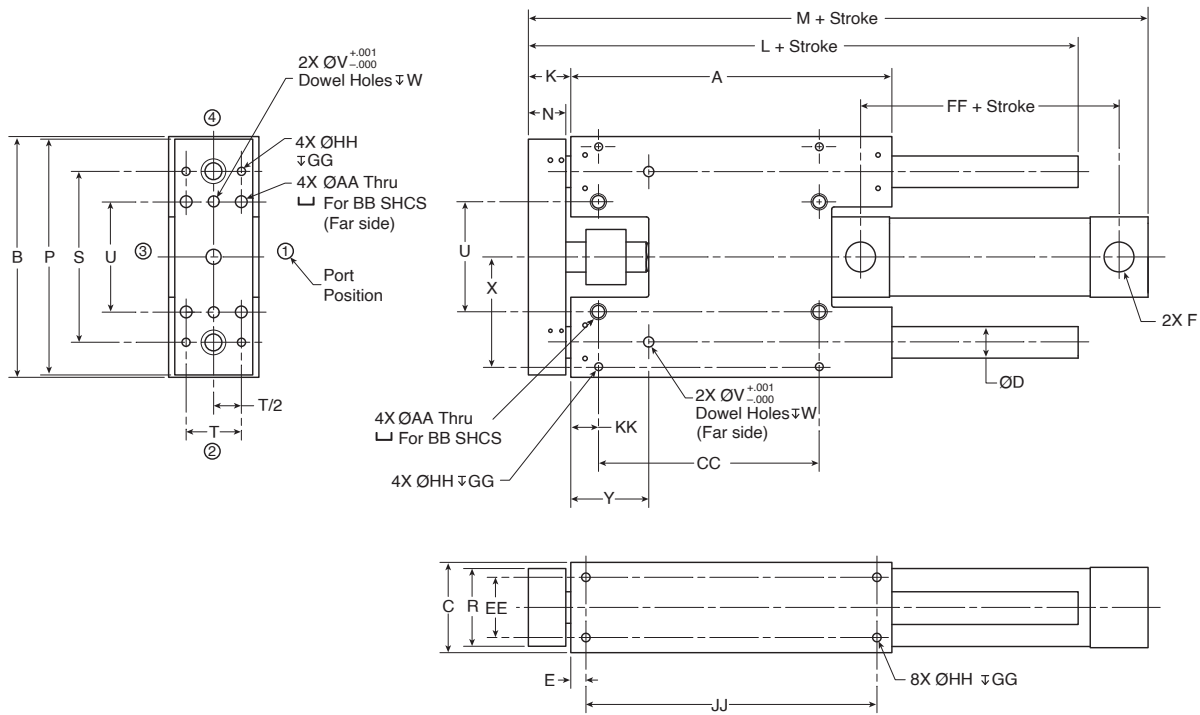

Model	A	B	C	Ds*	Do**	E	F NPTF	F BSPP	K	L	M	N	P	R	S	T
HBR15	8.00	6.00	2.25	20mm (0.79)	25mm (0.98)	0.375	1/4 1	1/4	1.06	9.94	11.19	0.94	5.88	1.94	4.250	1.375
HBR20	10.00	7.25	2.75	25mm (0.98)	30mm (1.18)	0.500	3/8	1/4	1.31	12.39	13.44	1.19	7.13	2.44	5.000	1.750
HBR25	12.00	9.00	3.25	30mm (1.18)	35mm (1.38)	0.500	3/8	3/8	1.56	14.82	15.82	1.44	8.88	2.88	6.500	2.000

Model	U	V	W	X	Y	AA	BB	CC	EE	FF	GG	HH	JJ	KK
HBR15	2.750	0.251	0.27	2.750	1.938	0.28	1/4	5.500	1.500	2.31	0.50	1/4-20	7.25	0.69
HBR20	3.250	0.313	0.33	3.250	2.250	0.34	5/16	7.250	1.750	2.31	0.63	5/16-18	9.00	0.88
HBR25	3.750	0.376	0.39	4.000	2.760	0.41	3/8	9.000	2.250	2.38	0.75	3/8-16	11.00	1.00

\* Standard shafting  
\*\* Oversized shafting

All dimensions in inches unless otherwise noted.



For inventory, lead times, and kit lookup, visit [www.pdnplu.com](http://www.pdnplu.com)

**Shock Absorbers/Stroke Adjusters (A, A1)**

Adjustable shock absorbers are provided when this option is specified. These dissipate kinetic energy over a wide range of velocities and weights. Cylinder stroke is adjusted by moving the shock striker plate.

**Shock Absorber Adjustment Procedure:**

Proper adjustment is important to maximize a shock absorber's performance. With a range of zero to ten, shocks are factory preset at five. Cycle the slide to impact the shock absorber. Rotate the shock's adjustment knob to achieve smooth deceleration. Adjusting towards zero increases resistance.

If the initial impact is too hard, rotate the knob towards ten to lessen the resistance. If the final setting is less than one, a larger shock and/or slide should be considered. Tighten the adjusting knob set screw to maintain resistance

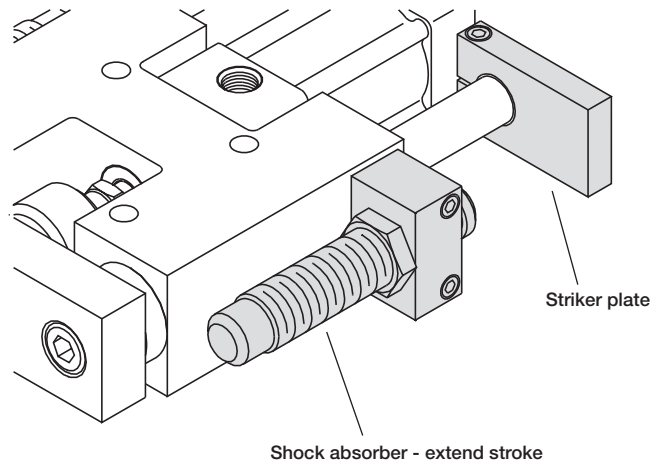

**Shock Absorbers/Stroke Adjusters Extend and Retract (A)**

**HBC: 15, 20, 25**

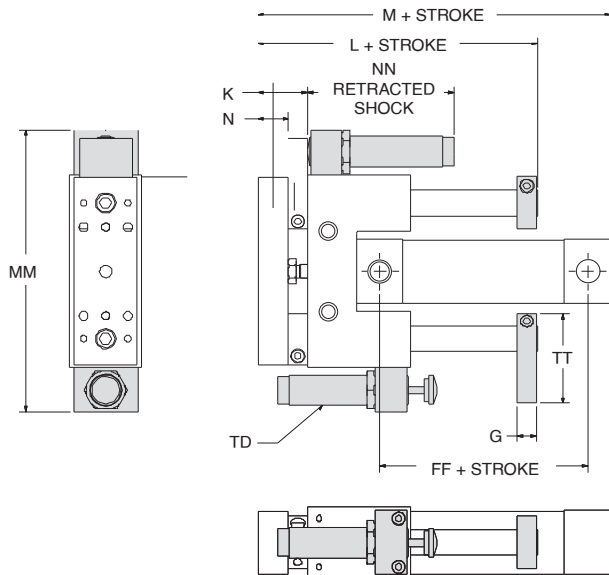

Model	G	K	L	M	N
HBC15	0.50	1.53	5.66	6.97	0.94
HBC20	0.63	1.88	6.95	7.82	1.19
HBC25	0.75	2.31	8.57	9.38	1.44

Model	FF	MM	NN	TD	TT
HBC15	2.56	8.75	4.62	M25 x 1.5	2.81
HBC20	2.56	10.00	5.86	M25 x 1.5	3.25
HBC25	2.63	12.50	4.45	1 1/4 - 12	4.13

All dimensions shown in inches.



For inventory, lead times, and kit lookup, visit [www.pdnplu.com](http://www.pdnplu.com)

Shock Absorbers/Stroke Adjusters Extend and Retract (A)

HBT: 07, 10, 12

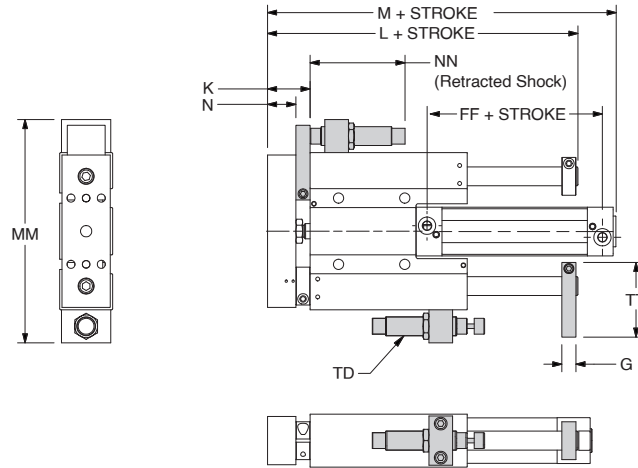

Thrust

Model	Gs*	Ks*	Go*	Ko*	Ls*	Lo*	M (P1F)	M (SRM)	N	FF (P1F)	MM	NN	TD	TT
HBT07	0.4 (9)	1.0 (26)	0.4 (11)	1.1 (28)	3.9 (100)	4.0 (102)	N/A	4.9 (124)	0.7 (17)	N/A	5.4 (136)	2.9 (74)	1.0 M12x	1.9 (48)
HBT10	0.4 (11)	1.3 (33)	0.5 (135)	1.4 (35)	4.8 (13)	5.0 (127)	N/A	5.5 (140)	0.9 (22)	N/A	6.7 (170)	3.2 (80.1)	1.5 M14x	2.2 (57)
HBT12	0.5 (13)	1.5 (37)	0.6 (15)	1.5 (39)	5.4 (136)	5.5 (140)	7.9 (200)	5.5 (140)	0.9 (24)	2.7 (68)	7.4 (188)	3.2 (80.1)	1.5 M14x	2.6 (66)

Dimensions in inches (mm)

\* s = standard, o = oversized

HBT / HBR: 15, 20, 25

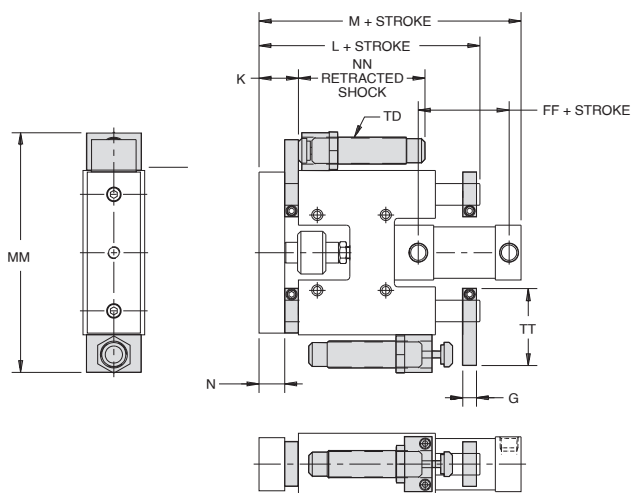

Model	G	K	L	M	N
HBT15	0.50	1.53	7.31	8.81	0.94
HBT20	0.63	1.88	8.44	9.75	1.19
HBT25	0.75	2.31	10.06	11.31	1.44

Model	FF	MM	NN	TD	TT
HBT15	2.56	8.75	4.62	M25 x 1.5	2.81
HBT20	2.56	10.00	5.86	M25 x 1.5	3.25
HBT25	2.63	12.50	4.45	1 1/4 - 12	4.13

Model	G	K	L	M	N
HBR15	0.50	1.53	10.41	11.90	0.94
HBR20	0.63	1.88	12.95	14.26	1.19
HBR25	0.75	2.31	15.57	16.82	1.44

Model	FF	MM	NN	TD	TT
HBR15	2.56	8.75	4.62	M25 x 1.5	2.81
HBR20	2.56	10.00	5.86	M25 x 1.5	3.25
HBR25	2.63	12.50	4.45	1 1/4 - 12	4.13

All dimensions shown in inches.



For inventory, lead times, and kit lookup, visit [www.pdnplu.com](http://www.pdnplu.com)

Options

Shock Absorbers Extend Only (A1)

HBC: 15, 20, 25

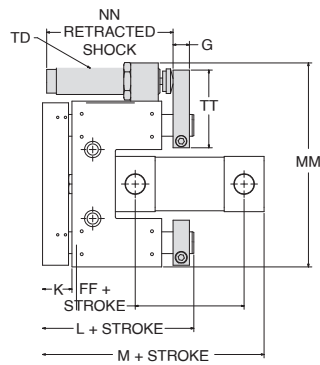

Model	G	K	L	M	N
HBC15	0.50	1.06	5.19	6.38	0.94
HBC20	0.63	1.31	6.39	7.13	1.19
HBC25	0.75	1.56	7.82	8.50	1.44

Model	FF	MM	NN	TD	TT
HBC15	2.44	7.38	4.62	M25 x 1.5	2.81
HBC20	2.44	8.63	5.86	M25 x 1.5	3.25
HBC25	2.50	10.75	4.45	1 1/4 - 12	4.13

HBT: 07, 10, 12

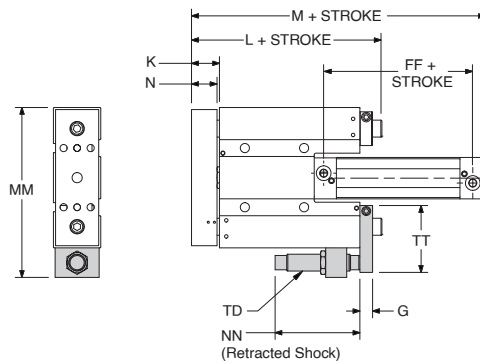

Thrust

Model	Gs*	Go*	K	Ls*	Lo*	M (P1F)	M (SRM)	N	FF (P1F)	MM	NN	TD	TT
HBT07	0.4 (9)	0.4 (11)	0.8 (20)	3.9 (100)	4.0 (102)	N/A	4.5 (115)	0.7 (17)	N/A	4.6 (117)	2.9 (74)	1.0 M12x (48)	1.9 (48)
HBT10	0.4 (11)	0.5 (13)	1.0 (25)	4.8 (123)	5.0 (127)	N/A	5.1 (129)	0.9 (22)	N/A	5.7 (146)	3.2 (80.1)	1.5 M14x (57)	2.2 (57)
HBT12	0.5 (13)	0.6 (15)	1.1 (27)	5.4 (136)	5.5 (140)	7.4 (187)	5.0 (127)	0.9 (24)	2.7 (68)	6.5 (164)	3.2 (80.1)	1.5 M14x (66)	2.6 (66)

Dimensions in inches (mm)

\* s = standard, o = oversized

HBT / HBR: 15, 20, 25

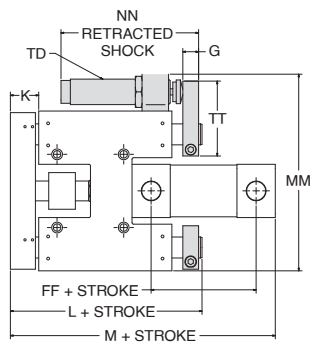

Model	G	K	L	M	N
HBT15	0.50	1.06	6.94	8.32	0.94
HBT20	0.63	1.31	7.88	9.07	1.19
HBT25	0.75	1.56	9.31	10.44	1.44

Model	FF	MM	NN	TD	TT
HBT15	2.44	7.38	4.62	M25 x 1.5	2.81
HBT20	2.44	8.63	5.86	M25 x 1.5	3.25
HBT25	2.50	10.75	4.45	1 1/4 - 12	4.13

Model	G	K	L	M	N
HBR15	0.50	1.06	9.94	11.31	0.94
HBR20	0.63	1.31	12.39	13.57	1.19
HBR25	0.75	1.56	14.82	15.94	1.44

Model	FF	MM	NN	TD	TT
HBR15	2.44	7.38	4.62	M25 x 1.5	2.81
HBR20	2.44	8.63	5.86	M25 x 1.5	3.25
HBR25	2.50	10.75	4.45	1 1/4 - 12	4.13

All dimensions shown in inches.



For inventory, lead times, and kit lookup, visit [www.pdnplu.com](http://www.pdnplu.com)

**Options**

**Shock Absorber Specifications**

SERIES	SHOCK #	Stroke Length (in)	E3 Max Energy/Cycle Inch Pounds	E4 Max Energy/Hour in lb/hour	WE Effective Weight lbs
HBT07	MA35M	0.40	35	53,000	13-125
HBT10	MA150M-BS	0.50	150	300,000	2-200
HBT12	MA150M-BS	0.50	150	300,000	2-200
HB*15	MA600M	1.00	600	600,000	20-3,000
HB*20	MA900M	1.58	900	800,000	30-4,500
HB*25	MA3325	0.91	1500	670,000	20-3,800

Please reference shock sizing information beginning on page M4



Guided Cylinders

P5T Series

HB Series

P5E Series



For inventory, lead times, and kit lookup, visit [www.pdnplu.com](http://www.pdnplu.com)



Options

Bumpers/Adjustable Stop Collars (B, B1, B4)

Bumpers absorb shock, reduce noise and permit faster cycle times thereby increasing production rates. They can be placed on the extend, retract or both positions.

When bumpers are specified, an adjustable stop collar is supplied on the extend stroke as standard. An extend stop collar provides travel adjustment. A stop collar can also be specified for the retract stroke. This stop collar is optional and is only provided if requested.

**Note:** Stop collars must be adjusted evenly to avoid creating a moment between the guide rods.

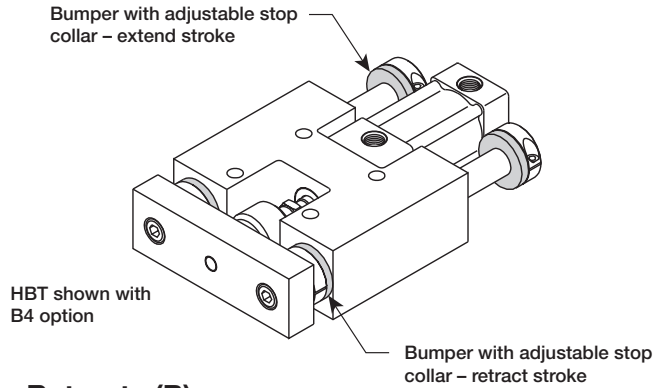

Bumper & Adjustable Stop Collar, Extend, Bumper Retracts (B)

HBC: 15, 20, 25

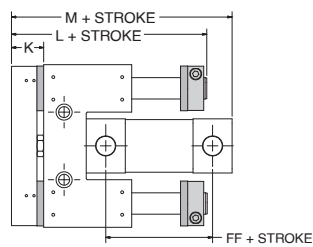

Model	K	L	M	FF
HBC15	1.19	5.32	6.62	2.56
HBC20	1.44	6.51	7.38	2.56
HBC25	1.69	7.94	8.75	2.63

HBT: 07, 10, 12

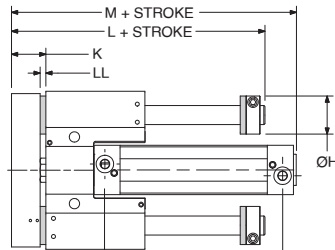

Thrust

Model	Hs*	Ho*	K	Ls*	Lo*	M (P1F)	M (SRM)	N	FF (P1F)	LL
HBT07	0.9 (24)	1.1 (28)	0.9 (23)	3.9 (100)	4.0 (102)	N/A	4.7 (121)	0.7 (17)	N/A	0.2 (6)
HBT10	1.1 (28)	1.3 (34)	1.1 (28)	4.8 (123)	5.0 (127)	N/A	5.3 (135)	0.9 (22)	N/A	0.2 (6)
HBT12	1.3 (34)	1.6 (40)	1.2 (30)	5.4 (136)	5.5 (140)	7.6 (193)	5.2 (133)	0.9 (24)	2.7 (68)	0.2 (6)

Dimensions in inches (mm)

\* s = standard, o = oversized

HBT / HBR: 15, 20, 25

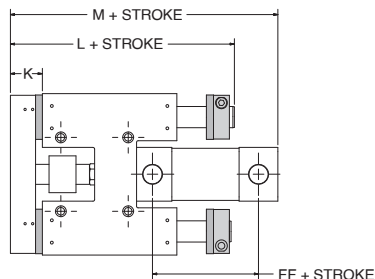

Model	K	L	M	FF
HBT15	1.19	7.07	8.56	2.56
HBT20	1.44	8.01	9.32	2.56
HBT25	1.69	9.44	10.69	2.63

Model	K	L	M	FF
HBR15	1.19	10.07	11.56	2.56
HBR20	1.44	12.51	13.82	2.56
HBR25	1.69	14.94	16.19	2.63

All dimensions shown in inches.



For inventory, lead times, and kit lookup, visit [www.pdnplu.com](http://www.pdnplu.com)

Options

Bumpers and Adjustable Stop Collars, Extend Only (B1)

HBC: 15, 20, 25

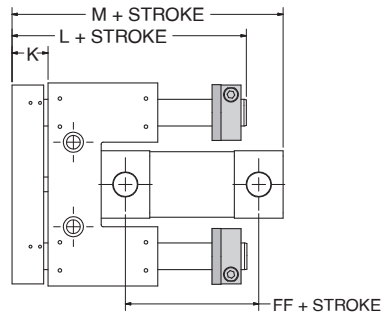

Model	K	L	M	FF
HBC15	1.06	5.19	6.37	2.44
HBC20	1.31	6.39	7.13	2.44
HBC25	1.56	7.82	8.50	2.50

HBT: 07, 10 12

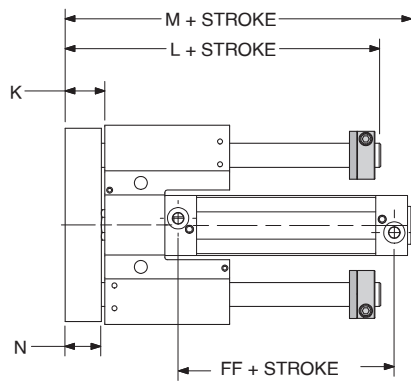

Thrust

Model	K	Lo*	Lo*	M (P1F)	M (SRM)	N	FF (P1F)
HBT07	0.8 (20)	4.3 (109)	4.4 (111)	N/A	4.5 (115)	0.7 (17)	N/A
HBT10	1.0 (25)	5.3 (134)	5.4 (138)	N/A	5.1 (129)	0.9 (22)	N/A
HBT12	1.1 (27)	5.8 (148)	6.0 (152)	7.3 (187)	5.0 (127)	0.9 (24)	2.7 (68)

Dimensions in inches (mm)

\* s = standard, o = oversized

HBT / HBR: 15, 20, 25

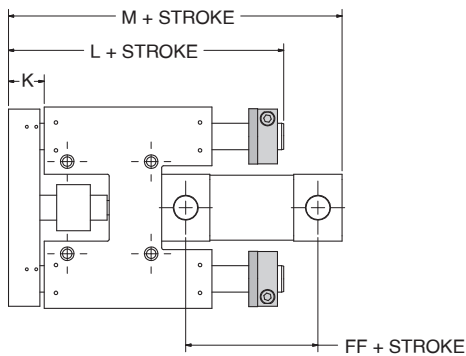

Model	K	L	M	FF
HBT15	1.06	6.94	8.31	2.44
HBT20	1.31	7.89	9.07	2.44
HBT25	1.56	9.32	10.44	2.50

Model	K	L	M	FF
HBR15	1.06	9.94	11.31	2.44
HBR20	1.31	12.39	13.57	2.44
HBR25	1.56	14.82	15.94	2.50

All dimensions shown in inches.



For inventory, lead times, and kit lookup, visit [www.pdnplu.com](http://www.pdnplu.com)

  
 Guided Cylinders  
 P5T Series  
 HB Series  
 P5E Series

**Bumpers and Adjustable Stop Collars, Both Ends (B4)**

**HBC: 15, 20, 25**

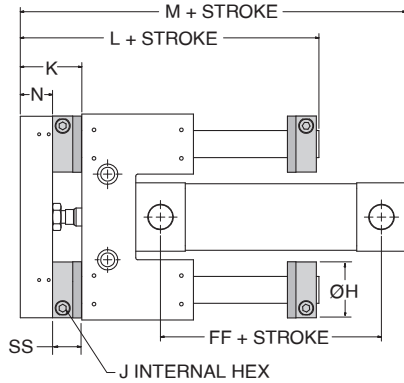

Model	H(s)*	H(o)**	J	K	L	M	N	FF	SS
HBC15	1.57	1.77	3/16	1.78	5.91	7.22	0.94	2.56	0.84
HBC20	1.77	2.12	3/16	2.03	7.10	7.97	1.19	2.56	0.84
HBC25	2.12	2.23	3/16	2.28	8.53	9.34	1.44	2.63	0.84

**HBT: 07, 10, 12**

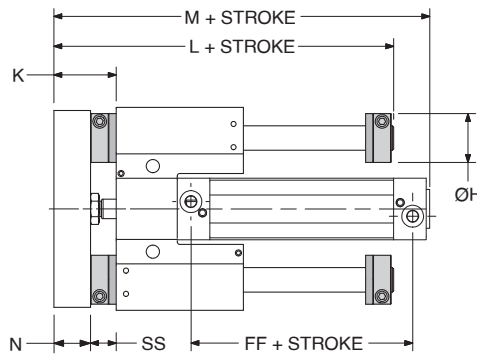

**Thrust**

Bore	Hs*	Ho*	Ks*	Ko*	Ls*	Lo*	Ms* (P1F)	Mo* (P1F)	Ms* (SRM)	Mo* (SRM)	N	FF (P1F)	SSs*	SSo*
HBT07	0.9 (24)	1.1 (28)	1.3 (32)	1.3 (34)	4.3 (109)	4.4 (111)	N/A	N/A	5.1 (130)	5.2 (132)	0.7 (17)	N/A	0.6 (15)	0.7 (17)
HBT10	1.1 (28)	1.3 (34)	1.5 (39)	1.6 (41)	5.3 (134)	5.4 (138)	N/A	N/A	5.7 (146)	5.8 (148)	0.9 (22)	N/A	0.7 (17)	0.7 (19)
HBT12	1.3 (34)	1.6 (40)	1.7 (43)	1.8 (45)	5.8 (148)	6.0 (152)	8.1 (206)	8.2 (208)	5.7 (146)	5.8 (148)	0.9 (24)	2.7 (68)	0.7 (19)	0.8 (21)

Dimensions in inches (mm)

\* s = standard, o = oversized

**HBT / HBR: 15, 20, 25**

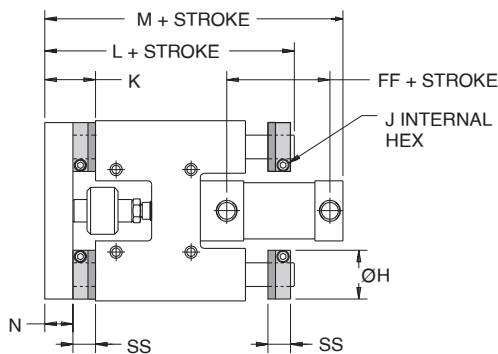

Model	H(s)*	H(o)**	J	K	L	M	N	FF	SS
HBT15	1.57	1.77	3/16	1.78	7.56	9.06	0.94	2.56	0.84
HBT20	1.77	2.12	3/16	2.03	8.69	10.00	1.19	2.56	0.84
HBT25	2.12	2.23	3/16	2.28	10.31	11.56	1.44	2.63	0.84

Model	H(s)*	H(o)**	J	K	L	M	N	FF	SS
HBR15	1.57	1.77	3/16	1.78	10.66	12.15	0.94	2.56	0.84
HBR20	1.77	2.12	3/16	2.03	13.10	14.41	1.19	2.56	0.84
HBR25	2.12	2.23	3/16	2.28	15.53	16.78	1.44	2.63	0.84

All dimensions shown in inches.



For inventory, lead times, and kit lookup, visit [www.pdnplu.com](http://www.pdnplu.com)

**Options**

**Bushings (D, T, T1, TC)**

Selection should be based on the following criteria:

Application Requirement	Ball Bearing	Composite
Precision	Excellent	Good
Friction	Low	Higher
Friction Coefficient	Constant	Variable
Precision Over Life of Bearing	Constant	Variable
Static Load Capacity	Good	Excellent
Dynamic Load Capacity	Good	Good with Lower Efficiency
Lubrication	Required	Not Required
Vibration Resistance	Fair	Excellent
Contamination Resistance	Fair	Excellent
Washdown Compatibility	Poor	Excellent

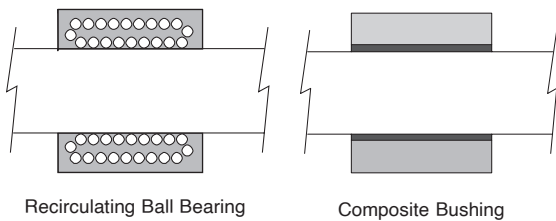

**Stainless Steel Shafts (K)**

Chrome plated, case-hardened carbon steel shafting is standard for slides. Stainless steel shafting can be specified for corrosive applications.

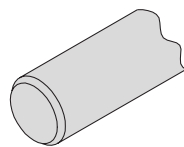

**NFPA Steel Air Cylinder (S)\***

Parker's 2A Series NFPA steel air cylinder is available for extremely rugged applications. Magnetic pistons are not available with this option. Consult factory for other switching or sensing options.

**145 PSI ISO Air Cylinder (F, F1)**

Parker's P1F series ISO 15552 aluminum cylinder is available for 145 PSI air service.

**250 PSI NFPA Air Cylinder (4A)**

Parker's 4MA Series aluminum NFPA air cylinders are available for general purpose use.

**250 PSI Round Body Air Cylinder (SR)**

Parker's SR series, 304 stainless steel cylinder body, non-repairable.

Construction is available for 250 PSI air service

**400 PSI NFPA Hydraulic Cylinder (4L)**

Parker's 4ML Series aluminum NFPA cylinder is available for 400 PSI hydraulic service. Cushions are not available.

**750 PSI NFPA Hydraulic Cylinder (S1)\***

Parker's 3L Series NFPA steel cylinder is available for hydraulic service requiring higher force and precise control.

Magnetic pistons are not available with this option. Consult factory for other switching or sensing options.

\* If cushions are specified with this option, the adjustment screw is located on the face opposite the port. Consult factory for other locations.

 Guided Cylinders  
 P5T Series  
 HB Series  
 P5E Series

Options

Rod Lock Cylinder (F1)

The P1F Series Rod Lock Cylinder incorporates a powerful piston rod locking device, which clamps the piston rod and locks it in position. The locking device is a spring lock with an air pressure release and is integrated into the front (head) cover of the cylinder. This increases the cylinder length as shown below.

In the absence of air signal pressure, full holding force is applied to the piston rod. When air is present at 4 bar (58 PSI), the locking device is released.

**Applications:** Vertical Guided Pneumatic Cylinders  
In the event of pressure loss  
In the event of electrical control failure

**Design Tip:** The piston rod should not be moving when the locking device is activated. The locking device is not intended to repeatedly brake movement. See sample pneumatic circuit.

**Note:** Rod locking cylinders automatically include cushions, but include cushions (“C”) in model code. If sensors are required, they must be ordered from the Electronic Sensors section of this catalog.

Technical Data

Maximum Pressure: 10 bar (145 PSI)  
Pressure Required to Unlock: 4 bar (58 PSI)<sup>1</sup>

<sup>1</sup> Signal pressure to port on locking device. Operation at pressures lower than 4 bar (58 PSI) may lead to inadvertent engagement of the rod lock device.

Model	Bore (mm)	Holding Force, lb (N)
12	32	122 (500)
15	40	193 (860)
20	50	303 (1345)
25	63	481 (2140)

All dimensions shown in inches.

Rod Lock Circuit

Lock valve must be maintained energized during cylinder motion, otherwise rod lock is engaged and cylinder valve shifts to mid position. For manual override of the rod lock, insert a shuttle valve and an auxiliary air supply to disable rod lock.

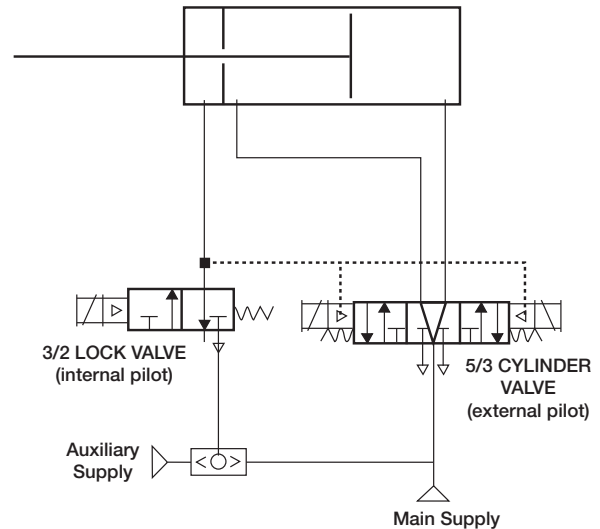

NOTES:

All P1F Rod Lock Versions are not intended for use in water service applications, or in environments that have high humidity levels and/or splashing fluids present.

**P**

Guided Cylinders

P5T Series

HB Series

P5E Series



Options

**NFPA Rod Lock Cylinder (4J)**

The 4MAJ Series Rod Lock Cylinder incorporates a powerful piston rod locking device, which clamps the piston rod and locks it in position. The locking device is a spring lock with an air pressure release and is attached to the front (head) cover of the cylinder. This increases the cylinder length as shown below.

In the absence of air signal pressure, full holding force is applied to the piston rod. When air is present at 60 PSIG or greater, the locking device is released. The manual override version is standard.

**Applications:** Vertical Guided Pneumatic Cylinders  
In the event of pressure loss  
In the event of electrical control failure

**Design Tip:** The piston rod should not be moving when the locking device is activated. The locking device is not intended to repeatedly brake movement. See sample pneumatic circuit.

**Note:** Rod locking cylinders automatically include cushions, but include cushions ("C") in model code. If sensors are required, they must be ordered from the Electronic Sensors section of this catalog.

**Technical Data**

Maximum Pressure: 100 PSIG  
Pressure Required to Unlock: 60 PSIG<sup>1</sup>

<sup>1</sup> Signal pressure to port on locking device. Operation at pressures lower than 60 PSIG may lead to inadvertent engagement of the rod lock device.

Model	Bore (inch)	Holding Force, lb
15	1-1/2	180
20	2	314
25	2-1/2	491

**No Cylinder (Q, Q1)**

The unit is supplied with cylinder mounting but no cylinder so that one may be field-added. Consult factory for required cylinder piston rod length.

**Fluorocarbon Seals (V)**

**Standard** abrasion-resistant nitrile seals should be used for general purpose applications with temperatures of 0 to 165°F.

**Fluorocarbon** seals are recommended for high temperature applications up to 250°F.

**Rod Lock Circuit**

Lock valve must be maintained energized during cylinder motion, otherwise rod lock is engaged and cylinder valve shifts to mid position. For manual override of the rod lock, insert a shuttle valve and an auxiliary air supply to disable rod lock.

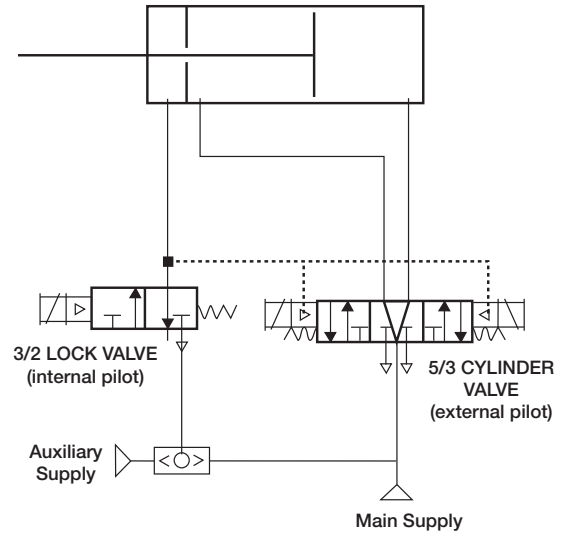

**NOTE:**

All 4MAJ rod lock cylinders are not intended for use in water service applications, or in environments that have high humidity levels and/or splashing fluids present.

Guided Cylinders  
 P5T Series  
 HB Series  
 P5E Series

Option	Temperature range (°F)
Shock Absorbers	32 to 150
Bumpers	0 to 200
Piston Magnets	0 to 165
Sensors	14 to 140



For inventory, lead times, and kit lookup, visit [www.pdnplu.com](http://www.pdnplu.com)

Options

Three Position Cylinder

The three position unit utilizes a duplex air cylinder to provide the center position. This option can be specified with all other options. However, bumpers and body mounted inductive proximity sensors operate on the fully extended and retracted positions only. Cylinder mounted reed and solid state sensors can be used to detect the center position of the slide.

Sample Circuit:

Consult factory for other control options.

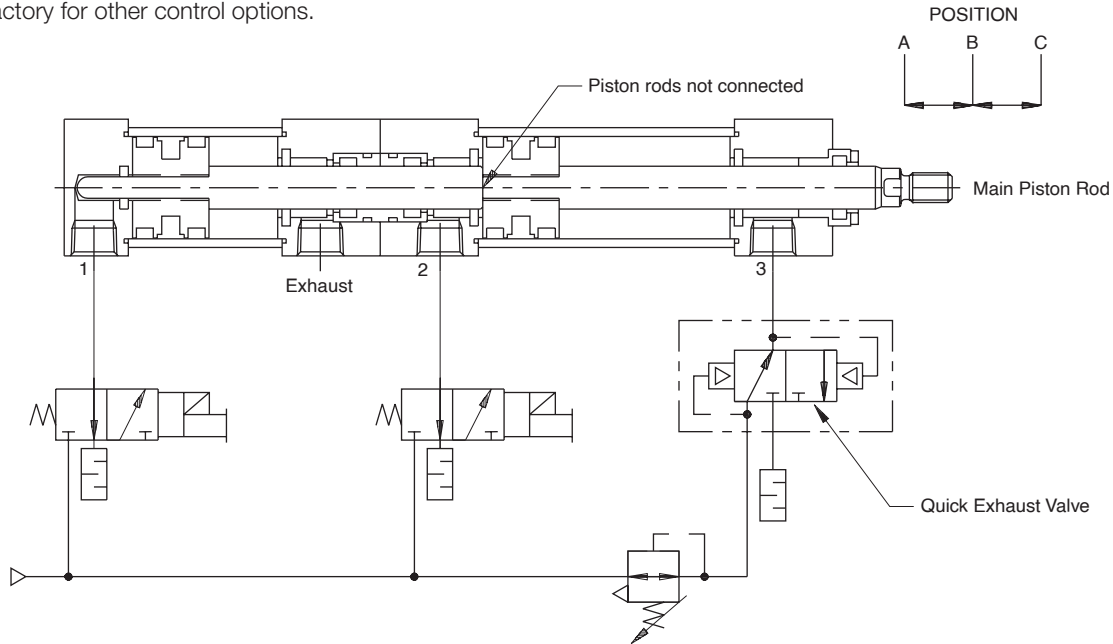

Operation:

**Position A** (fully retracted) is obtained by applying pressure to Port 3 with Ports 2 and 1 vented to atmosphere.

**Position B** (mid-position) is obtained by applying pressure to Port 1 while maintaining a lower pressure to Port 3. The pressure at Port 3 prevents the main piston rod from over-travelling. A quick exhaust valve can be used to maintain pressure while allowing full exhaust capability.

**Position C** (fully extended) is obtained by applying pressure to Port 2.

Dimensional Data:

Three position units utilize a longer cylinder. All other dimensions remain the same.

Model	A			B	C
	HBC	HBT	HBR		
15	10.38	12.31	15.31	2.38	2.31
20	11.12	13.06	17.56	2.38	2.31
25	12.57	14.50	20.01	2.38	2.38

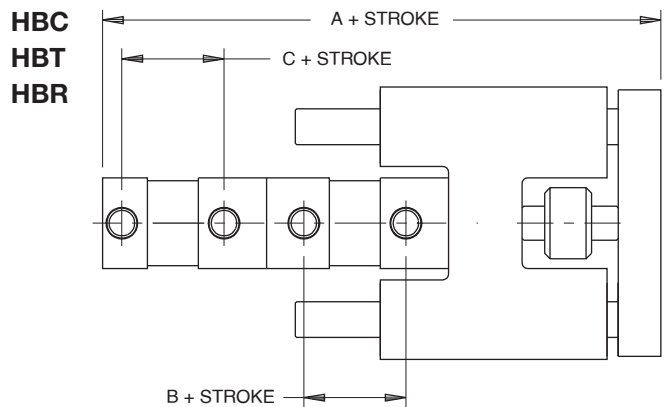

All dimensions shown in inches.

**P**

Guided Cylinders

P5T Series

HB Series

P5E Series



For inventory, lead times, and kit lookup, visit [www.pdnplu.com](http://www.pdnplu.com)

**Options**

**Solid State and Reed Sensors**

Sensors must be ordered separately.

Magnetic piston is standard.

See Electronic Sensors section for part numbers and sensor specifications.

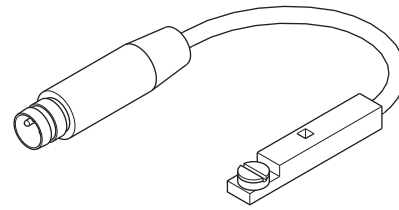

**Inductive Proximity Sensors**

The slides can also be ordered “prox ready” (J, J1). A magnetic piston is standard.

See Electronic Sensors section for sensor specifications.

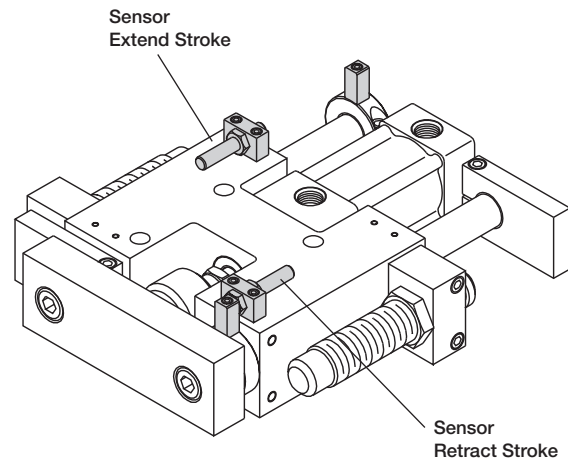

**P**

Guided Cylinders

P5T Series

HB Series

P5E Series

**HB Series Service Kits**

Cylinder type	Info location
4MA, 4ML	pages B87-B90
4MAJ	page B91
P1F	page B116

All dimensions shown in inches.



For inventory, lead times, and kit lookup, visit [www.pdnplu.com](http://www.pdnplu.com)



**P5E Series**

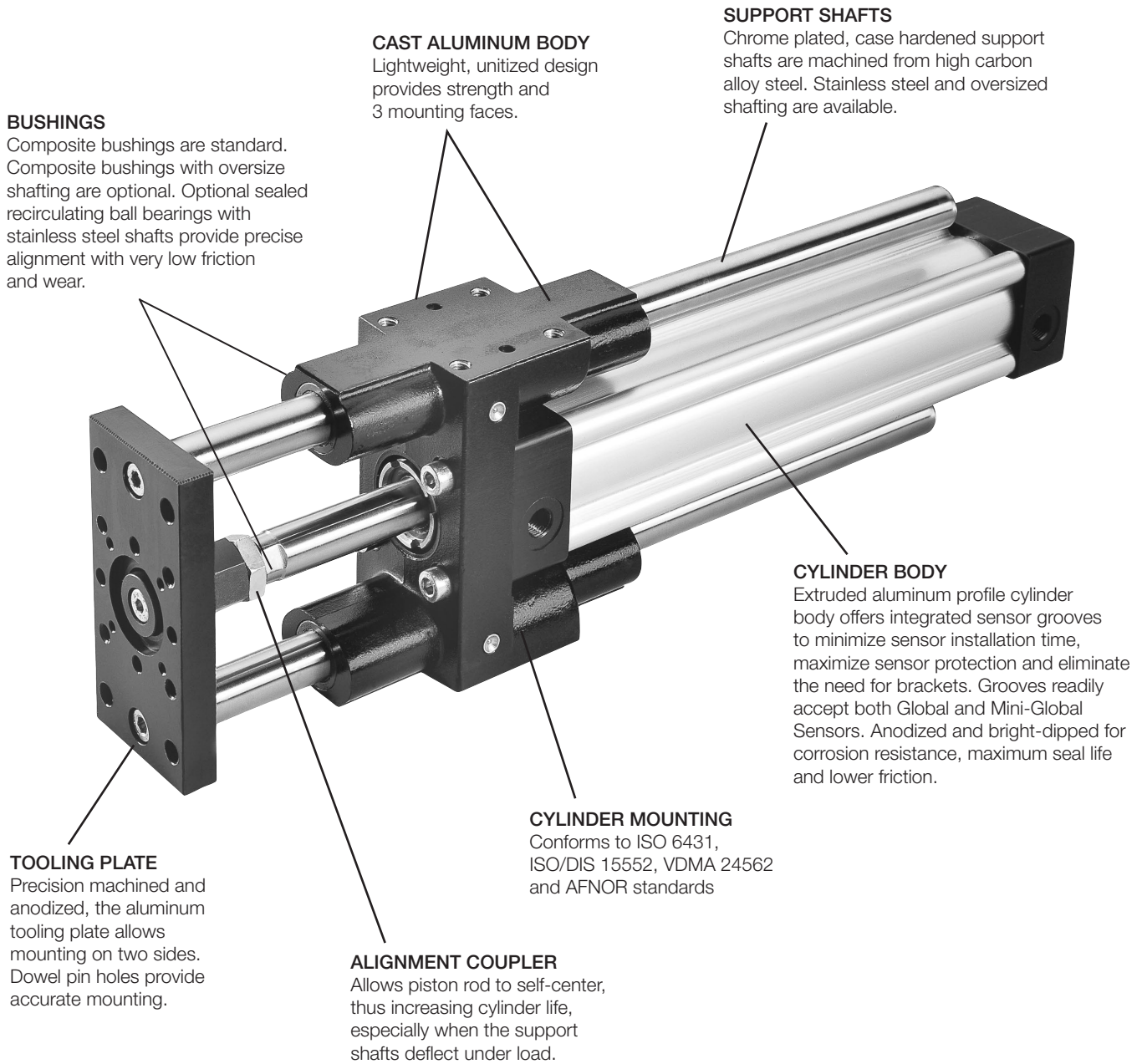

**BUSHINGS**  
Composite bushings are standard. Composite bushings with oversize shafting are optional. Optional sealed recirculating ball bearings with stainless steel shafts provide precise alignment with very low friction and wear.

**CAST ALUMINUM BODY**  
Lightweight, unitized design provides strength and 3 mounting faces.

**SUPPORT SHAFTS**  
Chrome plated, case hardened support shafts are machined from high carbon alloy steel. Stainless steel and oversized shafting are available.

**TOOLING PLATE**  
Precision machined and anodized, the aluminum tooling plate allows mounting on two sides. Dowel pin holes provide accurate mounting.

**ALIGNMENT COUPLER**  
Allows piston rod to self-center, thus increasing cylinder life, especially when the support shafts deflect under load.

**CYLINDER MOUNTING**  
Conforms to ISO 6431, ISO/DIS 15552, VDMA 24562 and AFNOR standards

**CYLINDER BODY**  
Extruded aluminum profile cylinder body offers integrated sensor grooves to minimize sensor installation time, maximize sensor protection and eliminate the need for brackets. Grooves readily accept both Global and Mini-Global Sensors. Anodized and bright-dipped for corrosion resistance, maximum seal life and lower friction.

<b>P</b>
Guided Cylinders
P5T Series
HB Series
P5E Series

**Features**

- Low profile guided assembly
- Powered by the P1D cylinder
- Bore sizes 32, 40, 50, 63, 80 and 100mm
- Strokes to any practical length
- Rod lock options available
- Composite and ball bearing options available

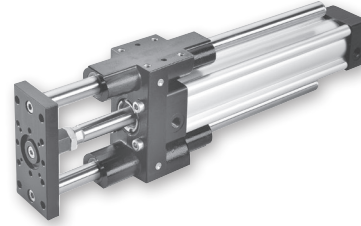

**Operating information**

Operating pressure:	145 PSIG (10 bar) maximum
Temperature range:	14°F to 165°F (-10°C to 74°C)
Filtration requirements:	40 micron, dry filtered air

**Ordering information**

P5E

**P5E - J 032 F G N 0250**

Shaft / Bearing Type		Bore Size		Cylinder Type <sup>3</sup>		Port Style		Stroke Length		Bumpers / Adjustable Stop Collars	
<b>J</b>	Composite Bearing, Chrome Plated Standard Shaft	<b>032</b>	32mm	<b>F</b>	P1D Removable Gland Cylinder	<b>H</b>	NPTF (std)	<b>0250</b> Specify Whole Millimeters, i.e. 0250 = 250mm Stroke		<b>N</b> None	
<b>M</b>	Composite Bearing, Chrome Plated Oversize Shaft <sup>1</sup>	<b>040</b>	40mm	<b>G</b>	P1D Removable Gland Cylinder with Cushions	<b>G</b>	BSPP				
<b>C</b>	Composite Bearing, Stainless Steel Shaft	<b>050</b>	50mm	<b>K</b>	P1D Rod Lock Cylinder with Cushions	<b>N</b>	NPTF With Flow Controls (std. female ports)	<b>B</b> Bumpers, Retract Only <sup>2</sup>		<b>E</b> Bumpers and Adjustable Stop Collars, Extend Only	
<b>H</b>	Ball Bearing, Stainless Steel Shaft	<b>063</b>	63mm	<b>S</b>	P1D Manual Override Rod Lock Cylinder with Cushions	<b>B</b>	BSPP With Flow Controls (ISO female ports)				
		<b>080</b>	80mm	<b>Q</b>	No Cylinder	<b>F</b>	Flow Controls, NPTF Port, Prestolok Tube (inch)	<b>R</b> Bumpers and Adjustable Stop Collars On Retract <sup>2</sup>		<b>T</b> Bumpers Both Ends, Adjustable Stop Collars on Extend <sup>2</sup>	
		<b>100</b>	100mm	<b>X</b>	Special – Please Specify	<b>P</b>	Flow Controls, BSPP Port, Prestolok Tube (mm)				

<sup>1</sup> Bumpers and Adjustable Stop Collars Are Not Available with Oversize Shaft Option.

<sup>2</sup> These Options Will Increase the Cylinder Length. To Achieve a Specific Usable Stroke Length with These Options, Add the Corresponding Value(s) in the Adder Table, Please Reference P5E Removable Gland Version to the Desired Stroke Length. See Bumper Options for Explanation.

Adders are Not Used When P1D Rod Lock (K) or P1D Manual Override Rod Lock (S) are Specified with Bumpers.

<sup>3</sup> Tie Rod Version or Composite Piston Option Must Be Specified as Special (X).

**Sensors**  
See section L for sensors.

Guided Cylinders

---

P5T Series

---

HB Series

---

P5E Series



**Specifications**

- Maximum operating pressure: 145 PSI (10 Bar)
- Support shaft sizes: ø12 to 30mm
- Cylinder mounting: ISO 6431, ISO/DIS 15552, VDMA 24 562 and AFNOR standards
- Mounting: Unrestricted
- Operating temperature range: -10°C to 74°C (14°F to 165°F)
- Filtration requirement: 40 micron, dry filtered air

Online sizing: <http://solutions.parker.com/virtualEngineer>



**Quick Reference Data**

Model (bore size)	Piston Rod (mm)	Bushings	Support Shafts (mm)	Piston Bore Area Non-Rod Side		Max.* Stroke (mm)	Theoretical Force		Weights	
				(mm <sup>2</sup> )	(in <sup>2</sup> )		Extend @80 psi (5.5 bar), N (lb)	Retract @80 psi (5.5 bar), N (lb)	Base Weight, kg (lb)	Per 100mm Stroke, kg (lb)
32	16	Standard	12	804	1.25	500	444 (100)	334 (75)	0.97 (2.14)	0.175 (0.39)
		Oversized	16							
40	16	Standard	16	1257	1.95	625	694 (156)	583 (131)	1.55 (3.41)	0.315 (0.69)
		Oversized	20							
50	20	Standard	20	1964	3.04	775	1081 (243)	907 (204)	2.56 (5.64)	0.495 (1.09)
		Oversized	25							
63	20	Standard	20	3117	4.83	950	1717 (386)	1544 (347)	3.57 (7.84)	0.495 (1.09)
		Oversized	25							
80	25	Standard	25	5027	7.79	1150	2771 (623)	2500 (562)	6.53 (14.4)	0.770 (1.70)
		Oversized	30							
100	25	Standard	25	7854	12.17	1350	4333 (974)	4061 (913)	8.76 (19.32)	0.770 (1.70)
		Oversized	30							

\* Ball bearings suggested on long-stroke applications. Consult factory for longer strokes.

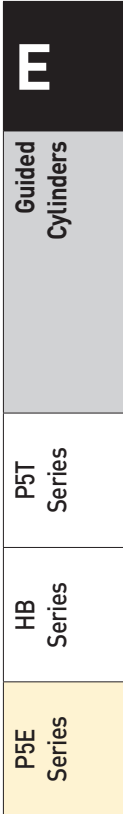

**Basic Version**

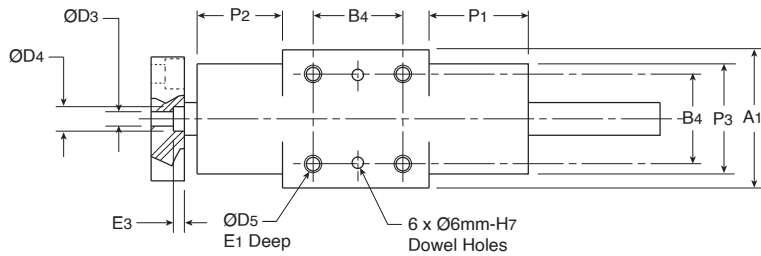
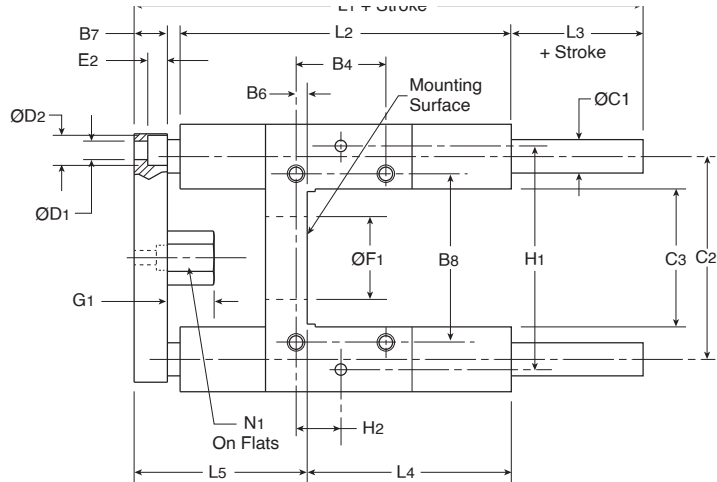
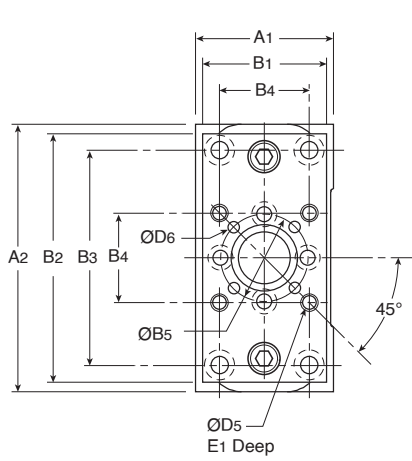

**Metric (inch)**

Bore Size	A1	A2	B1	B2	B3	B4	ØB5	B6	B7	B8	ØC1 std.	ØC1 O.S.	C2	C3	ØD1	ØD2	ØD3	ØD4	ØD5	ØD6
32	50 (1.97)	97 (3.82)	45 (1.77)	92 (3.62)	78 (3.07)	32.5 (1.28)	31.5 (1.24)	4 (0.16)	12.7 (0.50)	61 (2.40)	12 (0.47)	16 (0.63)	73.5 (2.89)	50 (1.97)	6.6 (0.26)	11 (0.43)	5.2 (0.20)	9 (0.35)	M6 x 1.00	4 (0.16)
40	58 (2.28)	115 (4.53)	50.8 (2.00)	110 (4.33)	84 (3.31)	38 (1.50)	31.5 (1.24)	11 (0.43)	12.7 (0.50)	69 (2.72)	16 (0.63)	20 (0.79)	86.5 (3.41)	58 (2.28)	6.6 (0.26)	11 (0.43)	5.2 (0.20)	9 (0.35)	M6 x 1.00	4 (0.16)
50	70 (2.76)	137 (5.39)	63 (2.48)	132 (5.20)	100 (3.94)	46.5 (1.83)	50 (1.97)	19 (0.75)	16 (0.63)	85 (3.35)	20 (0.79)	25 (0.98)	103.5 (4.07)	70 (2.76)	9 (0.35)	14 (0.55)	6.4 (0.25)	11 (0.43)	M8 x 1.25	4 (0.16)
63	85 (3.35)	152 (5.98)	82.5 (3.25)	145 (5.71)	105 (4.13)	56.5 (2.24)	50 (1.97)	15 (0.59)	16 (0.63)	100 (3.94)	20 (0.79)	25 (0.98)	118.5 (4.67)	85 (3.35)	9 (0.35)	14 (0.55)	6.4 (0.25)	11 (0.43)	M8 x 1.25	4 (0.16)
80	105 (4.13)	189 (7.44)	100 (3.94)	180 (7.09)	130 (5.12)	72 (2.83)	76 (2.99)	21 (0.83)	19 (0.75)	130 (5.12)	25 (0.98)	30 (1.18)	147 (5.79)	105 (4.13)	11 (0.43)	17 (0.67)	8.4 (0.33)	14 (0.55)	M10 x 1.50	6 (0.24)
100	130 (5.12)	213 (8.39)	120 (4.72)	200 (7.87)	150 (5.91)	89 (3.50)	76 (2.99)	24.5 (0.97)	19 (0.75)	150 (5.91)	25 (0.98)	30 (1.18)	171.5 (6.75)	130 (5.12)	11 (0.43)	17 (0.67)	8.4 (0.33)	14 (0.55)	M10 x 1.50	6 (0.24)

Bore Size	E1	E2	E3	ØF1	G1	H1	H2	L1	L2	L3	L4	L5	N1	P1	P2	P3	Port Size	Piston Rod Thread
32	12 (0.47)	7 (0.28)	4 (0.16)	30 (1.18)	17 (0.67)	81 (3.19)	16 (0.63)	153 (6.02)	120 (4.72)	17 (0.67)	71 (2.80)	64.7 (2.55)	17 (0.67)	36 (1.42)	31 (1.22)	40 (1.57)	1/8	M10 x 1.25
40	12 (0.47)	7 (0.28)	4 (0.16)	35 (1.38)	24 (0.94)	99 (3.90)	19 (0.75)	166 (6.54)	130 (5.12)	20 (0.79)	71 (2.80)	74.7 (2.94)	17 (0.67)	36 (1.42)	36 (1.42)	44 (1.73)	1/4	M12 x 1.25
50	16 (0.63)	9 (0.35)	9 (0.35)	40 (1.57)	27 (1.06)	119 (4.69)	23 (0.91)	194 (7.64)	150 (5.90)	25 (0.98)	79 (3.11)	90 (3.54)	24 (0.94)	42 (1.65)	44 (1.73)	50 (1.97)	1/4	M16 x 1.5
63	16 (0.63)	9 (0.35)	9 (0.35)	45 (1.77)	27 (1.06)	132 (5.20)	28 (1.10)	224 (8.82)	180 (7.09)	25 (0.98)	109 (4.29)	90 (3.54)	24 (0.94)	58 (2.28)	44 (1.73)	60 (2.36)	3/8	M16 x 1.5
80	20 (0.79)	11 (0.43)	5 (0.19)	45 (1.77)	32 (1.26)	166 (6.54)	36 (1.42)	252 (9.92)	200 (7.87)	30 (1.18)	113 (4.45)	109 (4.29)	30 (1.18)	50 (1.97)	52 (2.05)	70 (2.76)	3/8	M20 x 1.5
100	20 (0.79)	11 (0.43)	5 (0.20)	55 (2.17)	32 (1.26)	190 (7.48)	45 (1.77)	272 (10.71)	220 (8.66)	30 (1.18)	128 (5.04)	114 (4.49)	30 (1.18)	49 (1.93)	51 (2.01)	70 (2.76)	1/2	M20 x 1.5



For inventory, lead times, and kit lookup, visit [www.pdnplu.com](http://www.pdnplu.com)

**Guided Cylinders**  
 P5T Series  
 HB Series  
 P5E Series

P1D Removable Gland Version

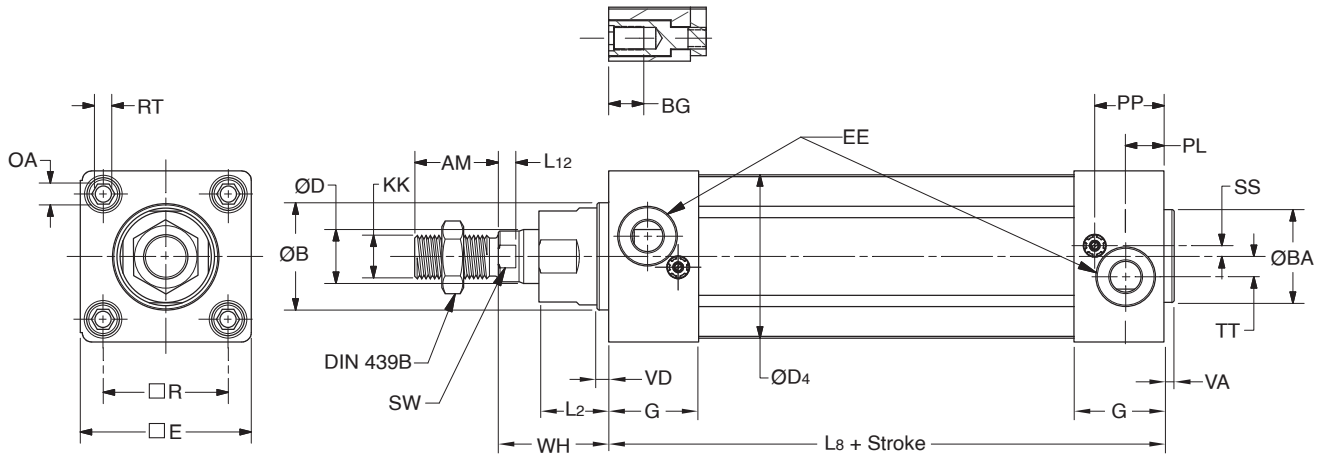

Dimensions

Cylinder Bore	AM mm	B mm	BA mm	BG mm	D mm	D4 mm	E mm	EE		G mm	KK	L2 mm	L8 mm	L12 mm
								BSPP	NPTF/BSPT					
32	22	30	30	16	12	45.0	46.5	G1/8	1/8	28.5	M10x1.25	18	94	6.0
40	24	35	35	16	16	52.0	52.0	G1/4	1/4	33.0	M12x1.25	20	105	6.5
50	32	40	40	16	20	60.7	63.5	G1/4	1/4	33.5	M16x1.5	26	106	6.5
63	32	45	45	16	20	71.5	76.0	G3/8	3/8	39.5	M16x1.5	26	121	6.5
80	40	45	45	17	25	86.7	95.5	G3/8	3/8	39.5	M20x1.5	33	128	10.0
100	40	55	55	17	25	106.7	114.5	G1/2	1/2	44.5	M20x1.5	33	138	10.0

Cylinder Bore	OA mm	PL mm	PP mm	R mm	RT	SS mm	SW mm	TT mm	VA mm	VD mm	WH mm
32	6	13	21.8	32.5	M6	6.5	10	4.5	3.5	4.5	26
40	6	14	21.9	38.0	M6	8.0	13	5.5	3.5	4.5	30
50	8	14	25.9	46.5	M8	4.0	17	7.5	3.5	4.5	37
63	8	16	27.4	56.5	M8	6.5	17	11.0	3.5	4.5	37
80	6	16	30.5	72.0	M10	0	22	15.0	3.5	4.5	46
100	6	18	35.8	89.0	M10	0	22	20.0	3.5	4.5	51

S = Stroke

Tolerances

Cylinder Bore	B	BA mm	L8 mm	L9 mm	R mm	Stroke Tolerance
32	d11	d11	±0.4	±2	±0.5	+1/-0
40	d11	d11	±0.7	±2	±0.5	+1/-0
50	d11	d11	±0.7	±2	±0.6	+1/-0
63	d11	d11	±0.8	±2	±0.7	+1/-0
80	d11	d11	±0.8	±3	±0.7	+1/-0
100	d11	d11	±1.0	±3	±0.7	+1/-0

\*Stroke Adder for Cylinder Bumper Options

Cylinder Bore	Option				
	B	T	R	S	E
32, 40, 50	5	25	25	25	25
63, 80	(0.20)	(0.98)	(0.98)	(0.98)	(0.98)
100	5	5	25	25	0
	(0.20)	(0.20)	(0.98)	(0.98)	

Adder dimensions in mm (inch)

Note: Adders not used when P1D Rod Lock (K) and P1D Manual Override Rod Lock (S) are specified with bumpers.

**P1D Rod Lock (K, S)**

The P1D Series Rod Lock Cylinder incorporates a powerful piston rod locking device, which clamps the piston rod and locks it in position. The locking device is a spring lock with an air pressure release and is integrated into the front (head) cover of the cylinder. In the absence of air signal pressure, full holding force is applied to the piston rod. When air is present at 4 bar (58 psi), the locking device is released.

The design provides several valuable characteristics, such as:

- A holding force corresponding to a pressure of 7 bar (102 psi)
- A clean design, with the front (head) end cover and locking device built into a common block for compact installation.
- Easy to clean, well-sealed construction.
- Exhaust air from the locking device can be piped away when there are high demands for contaminant free environment.

**Note:** The P1D with rod lock product line is not intended for use in water service applications, or in environments that have high humidity levels and/or splashing fluids present.

**Specifications**

- Fluid Medium: Dry, filtered, compressed air
  - Maximum Cylinder Operating Pressure: 10 bar (145 PSI)
  - Required Pressure to Unlock<sup>1</sup>: 4 bar (58 PSI)
  - Minimum Torque Required for Override:
    - 32mm Bore = 0.9 N-m / 8 in-lbs
    - 40mm Bore = 0.9 N-m / 8 in-lbs
    - 50mm Bore = 2.7 N-m / 24 in-lbs
    - 63mm Bore = 2.7 N-m / 24 in-lbs
    - 80mm Bore = 27.1 N-m / 240 in-lbs
    - 100mm Bore = 36.6 N-m / 324 in-lbs
  - Maximum Operating Temperature: -10°C to 75°C, 14°F to 167°F
  - Maximum Cylinder Operating Speed: 5 feet per second
- <sup>1</sup> Signal pressure to port on locking device. Operation at pressures lower than 4 Bar (58 psi) may lead to inadvertent engagement of the rod lock device.

**Connection**

The signal air for the locking device can be obtained directly from a main air supply, or from the air supply serving the valve that controls the cylinder itself. For controlled ON/OFF operation of the locking device, a separate quick-venting valve is used.

The piston rod should not be moving when the locking device is activated. The locking device is not intended to brake a movement in repeated sequences.

**Holding Forces**

Bore size	Holding forces	
	(N)	(lbs)
32mm	550	123
40mm	860	193
50mm	1345	303
63mm	2140	481
80mm	3450	755
100mm	5390	1211

**Note:** All P1D Rod Lock Versions are not intended for use in water service applications, or in environments that have high humidity levels and/or splashing fluids present.

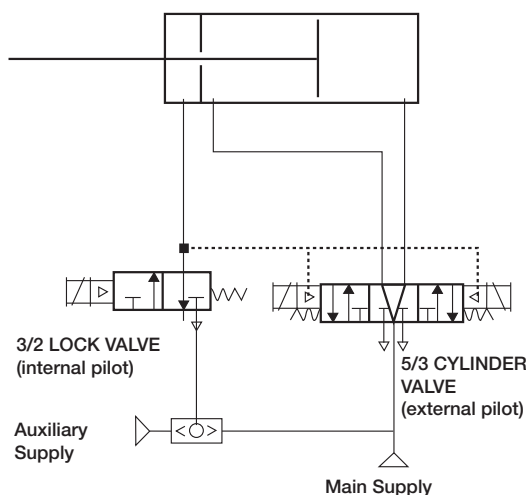

1. Lock valve must be maintained energized during cylinder motion, otherwise rod lock is engaged and cylinder valve shifts to mid position.
2. Cylinder valve must be maintained energized during extend or retract. Also keep energized at end of stroke until change of direction is desired.
3. Mid position of 5/3 Cylinder valve may be pressurized outlets if the combination of pressure load on the cylinder and inertia effects of the attached load do not exceed the holding force rating of the rod lock device, including allowance for wear.
4. Do not use cylinder lines for any logic functions — pressure levels vary too much.

  
 Guided Cylinders
   
  
 P5T Series
   
  
 HB Series
   
  
 P5E Series

P1D Rod Lock Version (K)

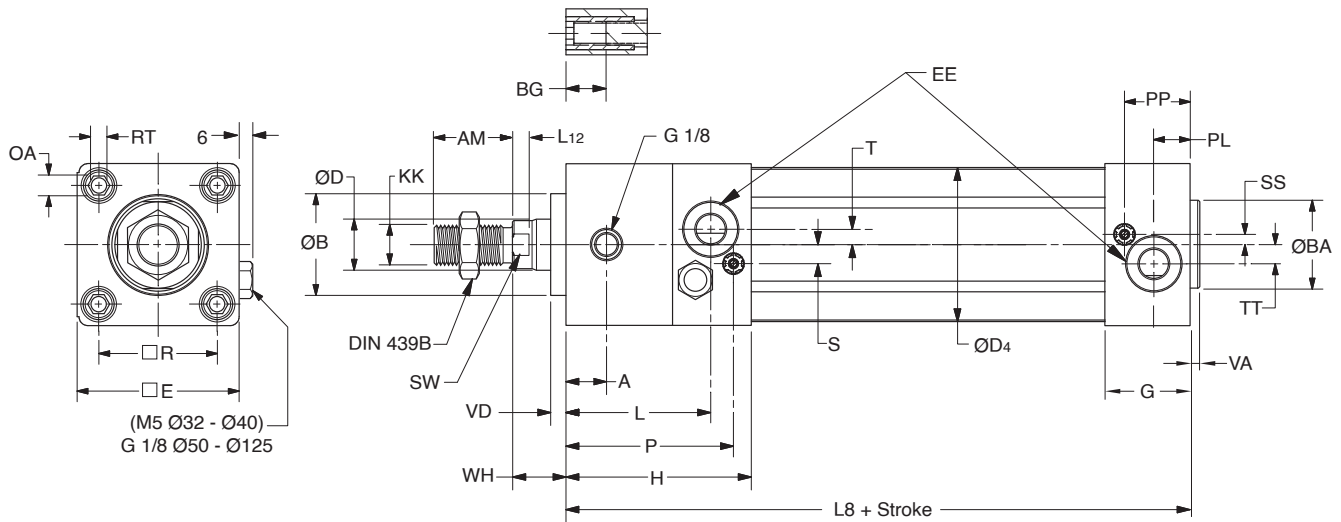

Dimensions

Cylinder Bore	A mm	AM mm	B mm	BA mm	BG mm	D mm	D4 mm	E mm	EE	G mm	H mm	KK	L mm	L8 mm	L12 mm
32	16	22	30	30	16	12	45.0	46.5	G1/8	28.5	71.5	M10x1.25	56.0	137	6.0
40	16	24	35	35	16	16	52.0	52.0	G1/4	33.0	77.0	M12x1.25	56.0	149	6.5
50	18	32	40	40	16	20	60.7	63.5	G1/4	33.5	80.5	M16x1.5	62.5	153	6.5
63	26	32	45	45	16	20	71.5	76.0	G3/8	39.5	96.5	M16x1.5	74.5	178	6.5
80	35	40	45	45	17	25	86.7	95.5	G3/8	39.5	110.5	M20x1.5	87.0	199	10.0
100	50	40	55	55	17	25	106.7	114.5	G1/2	44.5	132.5	M20x1.5	106.0	226	10.0

Cylinder Bore	OA mm	P mm	PL mm	PP mm	R mm	RT mm	S mm	SS mm	SW mm	T mm	TT mm	VA mm	VD mm	WH mm
32	6	64.8	13	21.8	32.5	M6	7	6.5	10	2.5	4.5	3.5	4.5	15
40	6	68.0	14	21.9	38.0	M6	9	8.0	13	2.0	5.5	3.5	4.5	16
50	8	73.5	14	25.9	46.5	M8	8	4.0	17	4.0	7.5	3.5	5.0	17
63	8	89.5	16	27.4	56.5	M8	8	6.5	17	2.0	11.0	3.5	5.0	17
80	6	101.5	16	30.5	72.0	M10	9	0	22	5.0	15.0	3.5	4.0	20
100	6	123.5	18	35.8	89.0	M10	12	0	22	6.0	20.0	3.5	4.0	20

Tolerances

Cylinder Bore	B mm	R mm	L8 mm	BA mm	Stroke-Length Tolerance mm
32	d11	±0.5	±0.4	d11	+1/-0
40	d11	±0.5	±0.7	d11	+1/-0
50	d11	±0.6	±0.7	d11	+1/-0
63	d11	±0.7	±0.8	d11	+1/-0
80	d11	±0.7	±0.8	d11	+1/-0
100	d11	±0.7	±1.0	d11	+1/-0

  
 Guided Cylinders  
 P5T Series  
 HB Series  
 P5E Series

P1D Rod Lock Version with Manual Override (S)

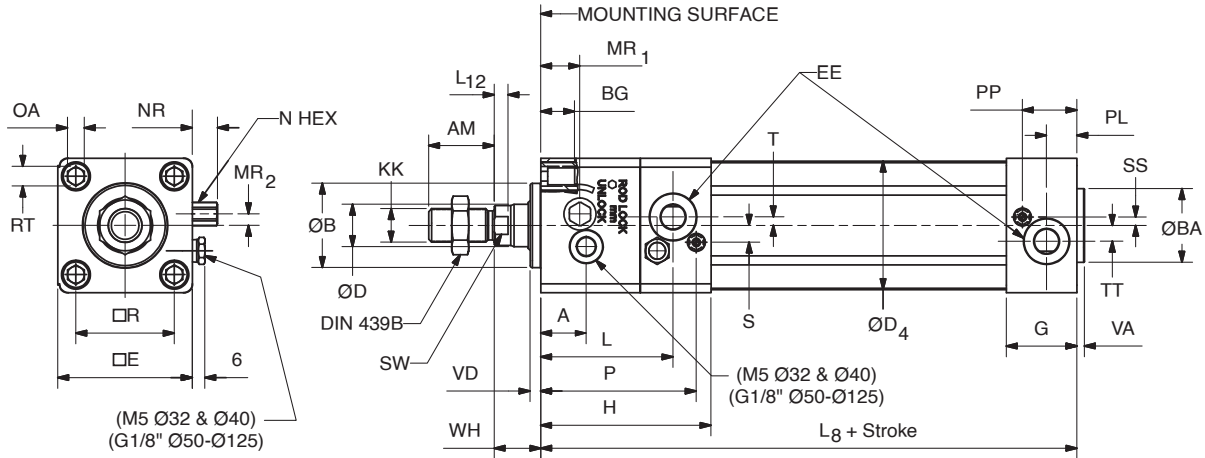

Dimensions

Cylinder Bore	A mm	AM mm	B mm	BA mm	BG mm	D mm	D4 mm	E mm	EE	G mm	H mm	KK	L mm	L8 mm	L12 mm	MR1 mm	MR2 mm
32	27.0	22	30	30	16	12	45.0	46.5	G1/8	28.5	71.5	M10X1.25	56.0	137	6.0	16.0	3.0
40	27.0	24	35	35	16	16	52.0	52.0	G1/4	33.0	77.0	M12X1.25	56.0	149	6.5	16.0	3.0
50	21.5	32	40	40	16	20	60.7	63.5	G1/4	33.5	80.5	M16X1.5	62.5	153	6.5	18.5	5.5
63	39.0	32	45	45	16	20	71.5	76.0	G3/8	39.5	96.5	M16X1.5	74.5	178	6.5	22.0	4.0
80	38.5	40	45	45	17	25	86.7	95.5	G3/8	39.5	110.5	M20X1.5	87.0	209	10.0	15.0	19.8
100	55.0	40	55	55	17	25	106.7	114.5	G1/2	44.5	132.5	M20X1.5	106.0	236	10.0	15.0	20.8

Cylinder Bore	N mm	NR mm	OA mm	P mm	PL mm	PP mm	R mm	RT	S mm	SS mm	SW mm	T mm	TT mm	VA mm	VD mm	WH mm
32	8	10.0	6	64.8	13	21.8	32.5	M6	7	6.5	10	2.5	4.5	3.5	4.5	15
40	8	10.0	6	68.0	14	21.9	38.0	M6	9	8.0	13	2.0	5.5	3.5	4.5	16
50	10	12.0	8	73.5	14	25.9	46.5	M8	8	4.0	17	4.0	7.5	3.5	5.0	17
63	10	12.0	8	89.5	16	27.4	56.5	M8	8	6.5	17	2.0	11.0	3.5	5.0	17
80	11	12.5	6	101.5	16	30.5	72.0	M10	9	0	22	5.0	15.0	3.5	14.0	30
100	11	12.5	6	123.5	18	35.8	89.0	M10	12	0	22	6.0	20.0	3.5	14.0	30

Tolerances

Cylinder Bore	B mm	R mm	L8 mm	BA mm	Stroke-Length Tolerance mm
32	d11	±0.5	±0.4	d11	+1/-0
40	d11	±0.5	±0.7	d11	+1/-0
50	d11	±0.6	±0.7	d11	+1/-0
63	d11	±0.7	±0.8	d11	+1/-0
80	d11	±0.7	±0.8	d11	+1/-0
100	d11	±0.7	±1.0	d11	+1/-0



**Bumpers / Adjustable Stop Collars**

Bumpers absorb shock, reduce noise and permit faster cycle times, thereby increasing production rates. They can be placed on the extend, retract or both positions.

When bumpers are specified on the extend stroke, an adjustable stop collar is required and provides travel adjustment. An optional stop collar can also be specified for the retract stroke.

**OPTIONS:**

- B** – Bumpers (retract only)
- E** – Bumpers, adjustable stop collars (extend only)
- R** – Bumpers, adjustable stop collars (retract only)
- S** – Bumpers, adjustable stop collars (both ends)
- T** – Bumpers both ends, adjustable stop collars on extend

**NOTES:**

1. Bumpers and adjustable stop collars are not available with oversize shaft options.
2. To achieve the desired useable stroke length with options B, E, T, R or S, the cylinder length will increase. See Stroke Adder table for cylinder dimensions adders.
3. Bumpers and adjustable stop collars on the extend stroke require additional cylinder stroke lengths on some bore sizes in order for the collars to clear the cylinder end cap. Therefore, cushions on extend stroke are not available with this option. See Stroke Adder table for cylinder dimension adders with options E, T or S.

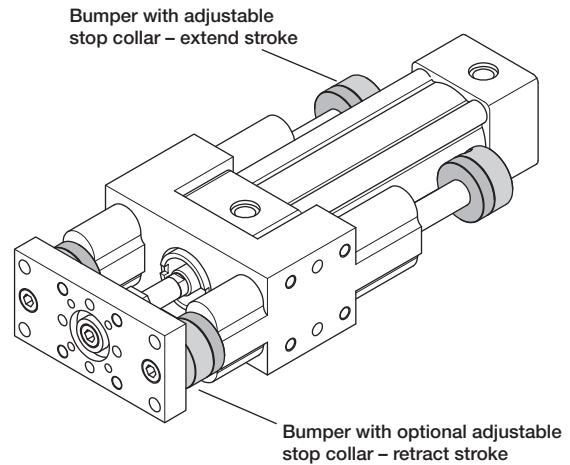

**Bumpers and adjustable stop collars, both ends (S)**

**Stroke Adder for Cylinder Bumper Options**

Cylinder Bore	Option				
	B	T	R	S	E
32, 40, 50	5	25	25	25	25
63, 80	(0.20)	(0.98)	(0.98)	(0.98)	(0.98)
100	5	5	25	25	0
	(0.20)	(0.20)	(0.98)	(0.98)	

Adder dimensions in mm (inch)

**Note:** Adders not used when P1D Rod Lock (K) and P1D Manual Override Rod Lock (S) are specified with bumpers.

**Sensors**

Optional solid state and reed sensors sense the position of the magnetic ring on the cylinder piston. Drop-in Global Sensors are installed into the integral sensor grooves on the cylinder body and are easily positioned. Magnetic piston is standard.

Order sensors separately. See Electronic Sensors section for part numbers and specifications.

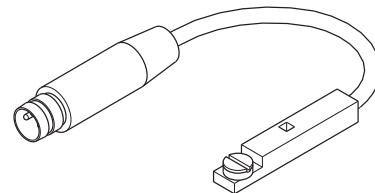

**E**  
Guided Cylinders  
P5T Series  
HB Series  
P5E Series

Options

Mounting Kits

Mounting kits conform to ISO 6431, ISO/DIS 15552, VDMA 24 562 and AFNOR standards.

Kits include 4 mounting screws.

Raw Material: Galvanized steel

Horizontal Mounting Kit (1)

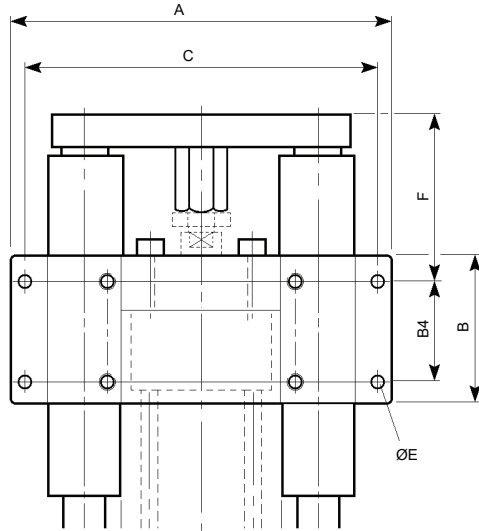

Vertical Mounting Kit (2)

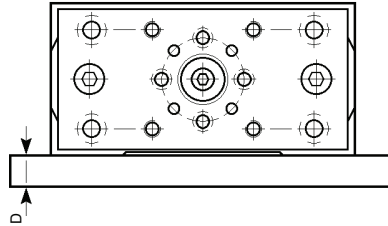
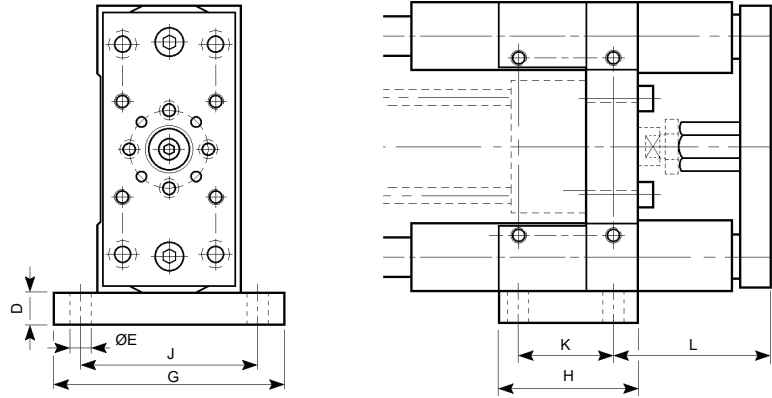

Dimensions & Weights

Bore Size	Mounting (1) Horizontal	Mounting (2) Vertical	A	B	B4	C	D	E	F	G	H	J	K	L	Weight, g (lb)	
															(1)	(2)
32	32-2801R	PIC-4KMB	128 (5.04)	50 (1.97)	32.5 (1.28)	116 (4.57)	10 (0.39)	6.6 (0.26)	60 (2.37)	80 (3.15)	47 (1.85)	64 (2.52)	32 (1.26)	60 (2.37)	500 (1.10)	230 (0.51)
40	40-2801R	PIC-4LMB	155 (6.10)	55 (2.16)	38 (1.50)	140 (5.51)	10 (0.39)	9 (0.35)	63 (2.48)	92 (3.62)	53 (2.09)	72 (2.83)	36 (1.42)	64 (2.52)	700 (1.54)	280 (0.62)
50	50-2801R	PIC-4MMB	175 (6.89)	70 (2.76)	46.5 (1.83)	160 (6.30)	12 (0.47)	9 (0.35)	70 (2.76)	113 (4.45)	65 (2.56)	90 (3.54)	45 (1.77)	71 (2.79)	1180 (2.60)	530 (1.17)
63	63-2801R	PIC-4NMB	190 (7.48)	80 (3.15)	56.5 (2.22)	175 (6.89)	12 (0.47)	9 (0.35)	74 (2.91)	129 (5.08)	74 (2.91)	100 (3.94)	50 (1.97)	77 (3.03)	1450 (3.20)	710 (1.57)
80	80-2801R	PIC-4PMB	240 (9.45)	100 (3.94)	72 (2.83)	218 (8.58)	16 (0.63)	11 (0.43)	89 (3.50)	153 (6.02)	97 (3.82)	126 (4.96)	63 (2.48)	93.5 (3.68)	3000 (6.61)	1590 (3.51)
100	100-2801R	PIC-4QMB	270 (10.63)	120 (4.72)	89 (3.50)	245 (9.65)	16 (0.63)	13 (0.51)	90.5 (3.56)	186 (6.93)	111 (4.37)	150 (5.91)	75 (2.95)	97.5 (3.84)	4100 (9.04)	2190 (4.83)

Note: All dimensions in mm or (inch) unless otherwise noted.

Guided Cylinders  
 P5T Series  
 HB Series  
 P5E Series



For inventory, lead times, and kit lookup, visit [www.pdnplu.com](http://www.pdnplu.com)

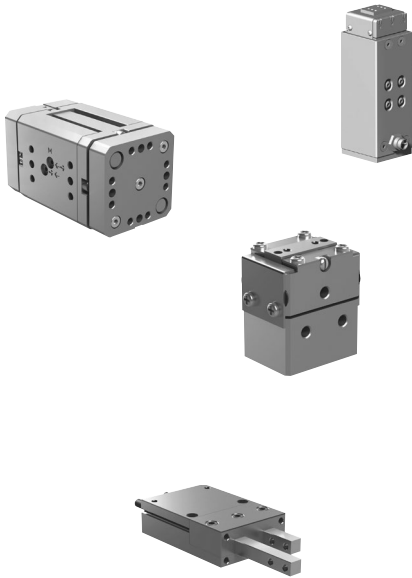

**Automation Products  
Pneumatic**

**Grippers**

Gripper Selection	F2
<b>Parallel Gripper</b>	
P5GV Series - Miniature Clean Room	F3-F4
P5GR Series - High Precision	F5-F7
P5GU Series - Clean Room, Harsh Environment	F8-F10
P5GN Series - Compact Parallel	F11-F13
P5GM Series - Parallel	F14-F16
P5GS Series - Wide Body	F17-F19
P5GT Series - Double Wedge	F20-F22
<b>Electric Gripper</b>	
P5GP Series	F23-F24
P5GQ Series - High Force	F25-F26
<b>3-Jaw Gripper</b>	
P5GW Series	F27-F30

**Escapements**

P5MD Series	F31-F32
-------------	---------

**Grippers**

	Series	Type	Grip Force Max.	mm or Degrees of Stroke	Spring Open	Spring Close	Clean Room	Page Number
	<b>P5GV</b>	Parallel	36 N	3.2mm to 6.3mm	No	No	Yes	F3
	<b>P5GR</b>	Parallel	120 N to 458 N	6.4mm to 38.1mm	No	Yes	Yes	F5
	<b>P5GU</b>	Parallel	116 N to 160 N	6.5mm to 25.4mm	No	No	Yes	F8
	<b>P5GN</b>	Parallel	62 N to 445 N	1.6mm to 9.5mm	No	No	Yes	F11
	<b>P5GM</b>	Parallel	62 N to 445 N	4.8mm to 25.4mm	No	No	Yes	F14
	<b>P5GS</b>	Parallel	222 N to 800 N	19.1mm to 73.5mm	No	No	No	F17
	<b>P5GT</b>	Parallel	178 N to 2669 N	6.4mm to 50.8mm	No	No	No	F20
	<b>P5GP</b>	Electric	111 N	0mm to 25mm	No	No	No	F23
	<b>P5GQ</b>	Electric	445 N to 1334 N	10mm to 20mm	No	No	No	F25
	<b>P5GW</b>	3-Jaw	682 N to 44354 N	4.0mm to 35mm	No	Yes	Yes	F27

**E**  
 Automation Products  
 Grippers  
 Escapements  
 Fittings



For inventory, lead times, and kit lookup, visit [www.pdnplu.com](http://www.pdnplu.com)

**P5GV Parallel Clean Room Series, Miniature**

- One piece lightweight aluminum body
- Stationary and non-contacting stainless steel cover eliminates the possibility of particle generation
- Bearings are preloaded for maximum support and zero side play
- The body has hard-coat anodize 60 RC with PTFE impregnation
- Units are lubricated with a clean-room grade grease
- Purge / scavenge port for extreme environments from dirty and gritty to clean-room class 10 or better
- Adjustable preload screw allows for adjustment of preload on roller bearings
- External components are made from corrosion resistant materials for resistance to de-ionized water or for use in FDA and medical parts handling applications
- Slip fit dowel pin holes located in body and jaws

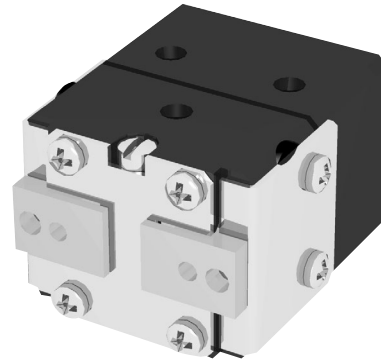

**Operating information**

Operating pressure:	3 to 7 bar (44 to 102 PSIG)
Temperature range:	
Nitrile seals (standard)	-35° to 80° C (-30° to 180° F)
Fluorocarbon seals (optional)	-30° to 120° C (-20° to 250° F)
Filtration requirements:	
Air filtration	40 micron or better
Air lubrication	Not necessary*
Air humidity	Low moisture content (dry)

\*Addition of lubrication will greatly increase service life

**Ordering Information: P5GV Miniature Clean Room Series**

Function	Bore Size (mm)	Ports (BSPP)	Stroke (mm)	Grip Force @ 7 bar (N)	Accuracy +/- mm	Repeatability +/-mm	Weight (kg)	Part Number
Double Acting, Nitrile	10	M3	3.2	36	0.05	0.03	0.024	<b>P5GV-010MSG003B</b>
Double Acting, Fluorocarbon	10	M3	3.2	36	0.05	0.03	0.024	<b>P5GV-010MFG003B</b>
Double Acting, Nitrile	10	M3	4.8	36	0.05	0.03	0.026	<b>P5GV-010MSG005B</b>
Double Acting, Fluorocarbon	10	M3	4.8	36	0.05	0.03	0.026	<b>P5GV-010MFG005B</b>
Double Acting, Nitrile	10	M3	6.3	36	0.05	0.03	0.034	<b>P5GV-010MSG006B</b>
Double Acting, Fluorocarbon	10	M3	6.3	36	0.05	0.03	0.034	<b>P5GV-010MFG006B</b>

Not available with sensors.

**F**

Automation Products

Grippers

Escapements

Fittings



For inventory, lead times, and kit lookup, visit [www.pdnplu.com](http://www.pdnplu.com)

**Loading information - P5GV**

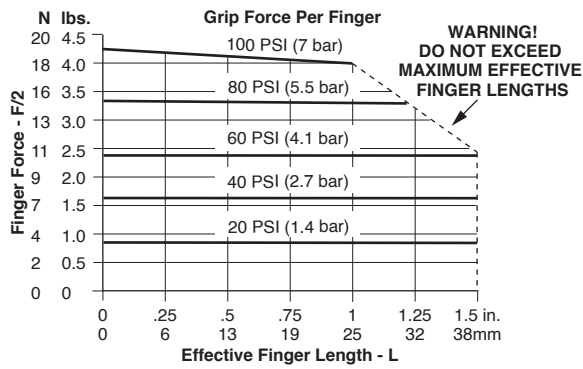

**Loading capacity† - P5GV**

	Static (metric)	Dynamic (metric)
Maximum Tensile T	89 N	31 N
Maximum Compressive C	89 N	31 N
Maximum Moment Mx	1 Nm	0.5 Nm
Maximum Moment My	2 Nm	0.6 Nm
Maximum Moment Mz	1 Nm	0.5 Nm

† Capacities are per set of jaws and are not simultaneous

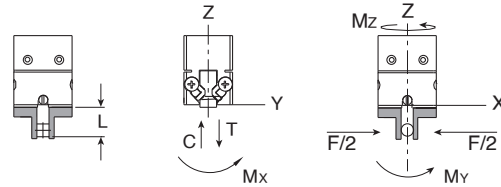

**Dimensions: P5GV Miniature Clean Room Series**

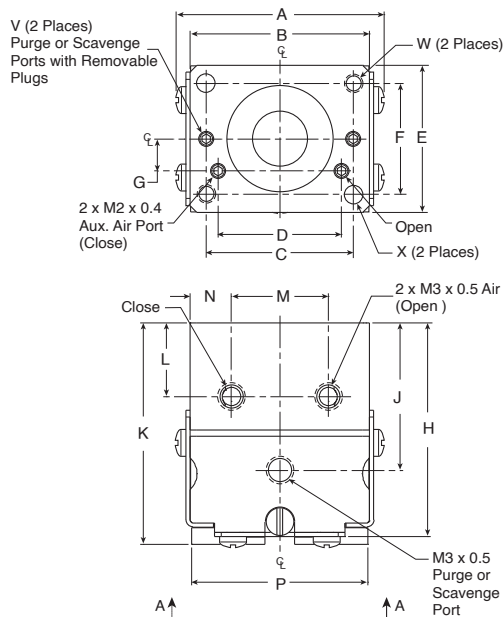

Unless otherwise noted all tolerances are as shown below

⌀ Dimensions are symmetrical about centerline  
 Third Angle Projection  
**Metric (mm)**  
 (0.) = (±.25)  
 (0.0) = (±.13)  
 (0.00) = (±.013)

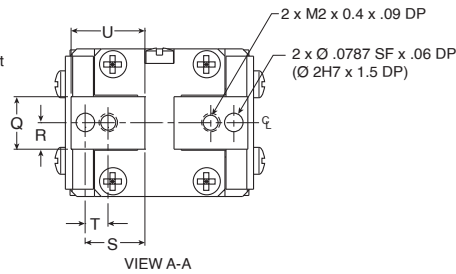

Part Number	A	B	C	D	E	F	G	H	J	K	L	M
<b>P5GV-010MS(F)G003B</b>	23	19.5	16.0	13.4	16.0	12.00	3.5	23	16	24.0	8	10.5
<b>P5GV-010MS(F)G005B</b>	24	21.0	16.0	13.4	16.0	12.00	3.5	25	17	25.5	9	10.5
<b>P5GV-010MS(F)G006B</b>	30	26.5	20.0	13.4	16.0	11.00	3.5	25	18	25.5	10	10.5

Part Number	N	P	Q	R	S	T	U	V	W	X
<b>P5GV-010MS(F)G003B</b>	4.5	Open 19.2 Closed 16	.569 ±0.03	2.8	6.50	2.5	8	M2 x 0.4	M2 x .18 4.5 Dp	Ø 2H7 x 3.3 Dp
<b>P5GV-010MS(F)G005B</b>	5.2	Open 20.8 Closed 16	.569 ±0.03	2.8	6.50	2.5	8	M2 x 0.4	M2 x 0.4 .18 Dp	Ø 2H7 x 3.3 Dp
<b>P5GV-010MS(F)G006B</b>	8.0	Open 126.4 Closed 20	.569 ±0.03	2.8	7.50	2.5	10	M2 x 0.5	M3 x 0.5 .20 Dp	Ø 3H7 x 5.0 Dp

Dimensions in millimeters

**Automation Products**  
**Grippers**  
**Escapements**  
**Fittings**



For inventory, lead times, and kit lookup, visit [www.pdnplu.com](http://www.pdnplu.com)

## P5GR Parallel High Precision Series

- Excellent parallelism and accuracy between gripper mounting surface and jaw surfaces
- H7 dowel pin holes in body and jaws. Jaws also have key slot for better finger alignment.
- Hardened plated jaws for wear resistance and longer life
- Top manifold air ports eliminates the need for airlines
- “Dual-V” roller bearings provide low friction motion and are preloaded for maximum support and zero side play
- One piece, aircraft quality aluminum body, has hard-coat anodized 60 RC with PTFE impregnation
- Standard purge / scavenge port used with vacuum for clean room environments or positive pressure for harsh environments and jaw surfaces
- Adjustable pre-load screws allows for adjustment of preload on roller bearings
- 4 standard air port locations; front, top and both sides
- Shielded design repels contamination from penetrating the “Dual-V” roller bearings
- Magnetic piston standard

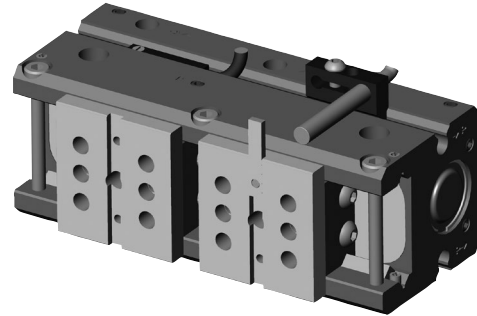

### Operating information

Pressure range (without springs):	0.3 to 7 bar (4 to 102 PSIG)
Pressure range (with springs):	
P5GR-010MSG006B & P5GR-010MSG013B	1.4 to 7 bar (20 to 102 PSIG)
P5GR-014MSG016B & P5GR-014MSG025B	3.4 to 7 bar (49 to 102 PSIG)
P5GR-021MSG025B	2.8 to 7 bar (41 to 102 PSIG)
P5GR-021MSG038B	2.1 to 7 bar (30 to 102 PSIG)
Temperature range:	
Nitrile seals (standard)	-35° to 80° C (-30° to 180° F)
Filtration requirements:	
Air filtration	40 micron or better
Air lubrication	Not necessary*
Air humidity	Low moisture content (dry)

\*Addition of lubrication will greatly increase service life

### Ordering Information: P5GR High Precision Series

Function	Bore Size (mm)	Ports (BSPP)	Stroke (mm)	Grip Force @ 7 bar (N)	Accuracy +/- mm	Repeatability +/-mm	Weight (kg)	Part Number
Double Acting Magnetic	10	M3	6.4	120	0.001	0.00005	0.16	<b>P5GR-010MSG006B</b>
Spring Closing, Magnetic	10	M3	6.4	120	0.001	0.00005	0.16	<b>P5GR-010DSG006B</b>
Double Acting Magnetic	10	M3	12.7	120	0.001	0.00005	0.20	<b>P5GR-010MSG013B</b>
Spring Closing, Magnetic	10	M3	12.7	120	0.001	0.00005	0.20	<b>P5GR-010DSG013B</b>
Double Acting Magnetic	14	M3	15.9	227	0.001	0.00005	0.48	<b>P5GR-014MSG016B</b>
Spring Closing, Magnetic	14	M3	15.9	227	0.001	0.00005	0.48	<b>P5GR-014DSG016B</b>
Double Acting Magnetic	14	M3	25.4	214	0.001	0.00005	0.57	<b>P5GR-014MSG025B</b>
Spring Closing, Magnetic	14	M3	25.4	214	0.001	0.00005	0.57	<b>P5GR-014DSG025B</b>
Double Acting Magnetic	21	M5	25.4	458	0.001	0.00005	1.02	<b>P5GR-021MSG025B</b>
Spring Closing, Magnetic	21	M5	25.4	458	0.001	0.00005	1.02	<b>P5GR-021DSG025B</b>
Double Acting Magnetic	21	M5	38.1	449	0.001	0.00005	1.41	<b>P5GR-021MSG038B</b>
Spring Closing, Magnetic	21	M5	38.1	449	0.001	0.00005	1.41	<b>P5GR-021DSG038B</b>

See Sensor section L for part numbers.



For inventory, lead times, and kit lookup, visit [www.pdnplu.com](http://www.pdnplu.com)

**Loading information - P5GR-010\*\*\*006**

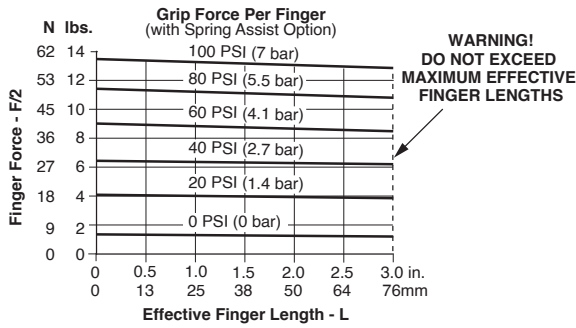

**Loading information - P5GR-014\*\*\*025**

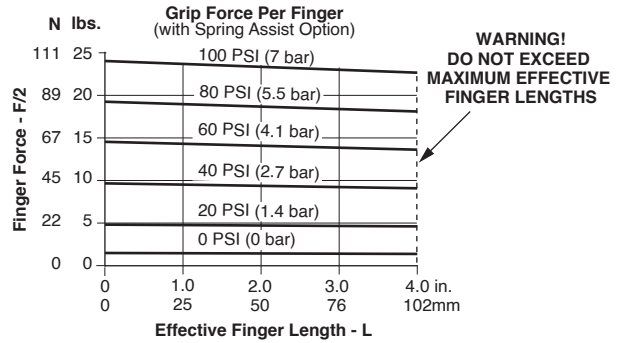

**Loading information - P5GR-010\*\*\*013**

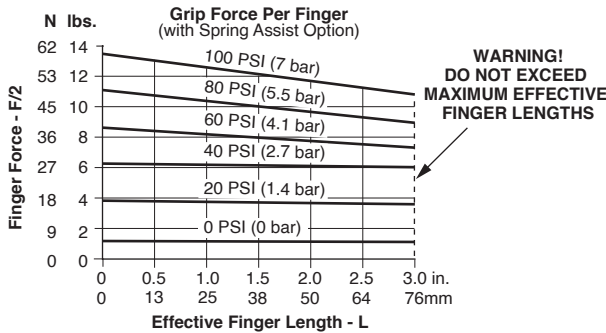

**Loading information - P5GR-021\*\*\*025**

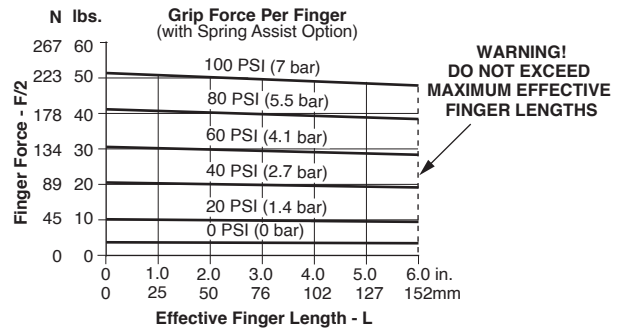

**Loading information - P5GR-014...016**

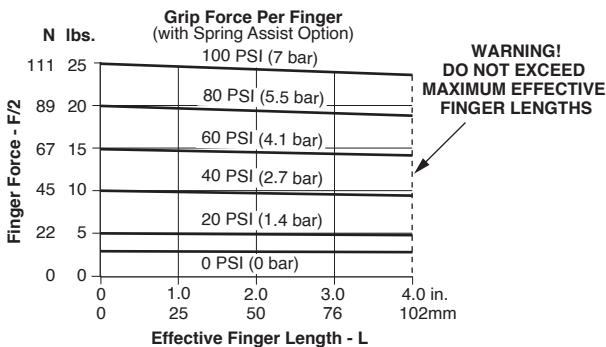

**Loading information - P5GR-021\*\*\*038**

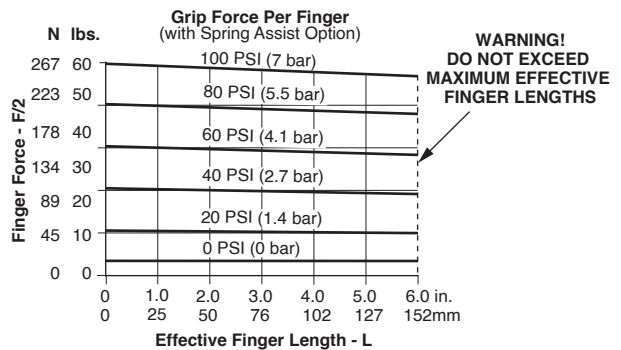

**Loading capacity† - P5GR High Precision Series**

	P5GR-010***006		P5GR-010***013		P5GR-014***016		P5GR-014***025		P5GR-021***025		P5GR-021***038	
	Static (metric)	Dynamic (metric)	Static (metric)	Dynamic (metric)	Static (metric)	Dynamic (metric)	Static (metric)	Dynamic (metric)	Static (metric)	Dynamic (metric)	Static (metric)	Dynamic (metric)
Maximum Tensile T	267 N	89 N	311 N	102 N	556 N	187 N	734 N	245 N	667 N	222 N	890 N	245 N
Maximum Compressive C	267 N	89 N	311 N	102 N	556 N	187 N	734 N	245 N	667 N	222 N	890 N	245 N
Maximum Moment Mx	4.0 Nm	1.4 Nm	5.6 Nm	1.9 Nm	9.0 Nm	3.1 Nm	11 Nm	3.7 Nm	34 Nm	11 Nm	45 Nm	15 Nm
Maximum Moment My	5.6 Nm	1.9 Nm	7.3 Nm	4.0 Nm	12 Nm	4.0 Nm	14 Nm	4.7 Nm	40 Nm	4.7 Nm	51 Nm	17 Nm
Maximum Moment Mz	4.0 Nm	1.4 Nm	5.6 Nm	1.9 Nm	9.0 Nm	3.1 Nm	11 Nm	3.7 Nm	34 Nm	11 Nm	45 Nm	15 Nm

† Capacities are per set of jaws and are not simultaneous

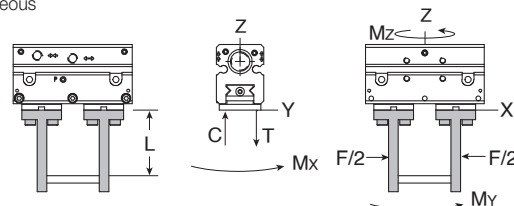

For inventory, lead times, and kit lookup, visit [www.pdnplu.com](http://www.pdnplu.com)

Automation Products  
 Grippers  
 Escapements  
 Fittings



**Dimensions: P5GR High Precision Series**

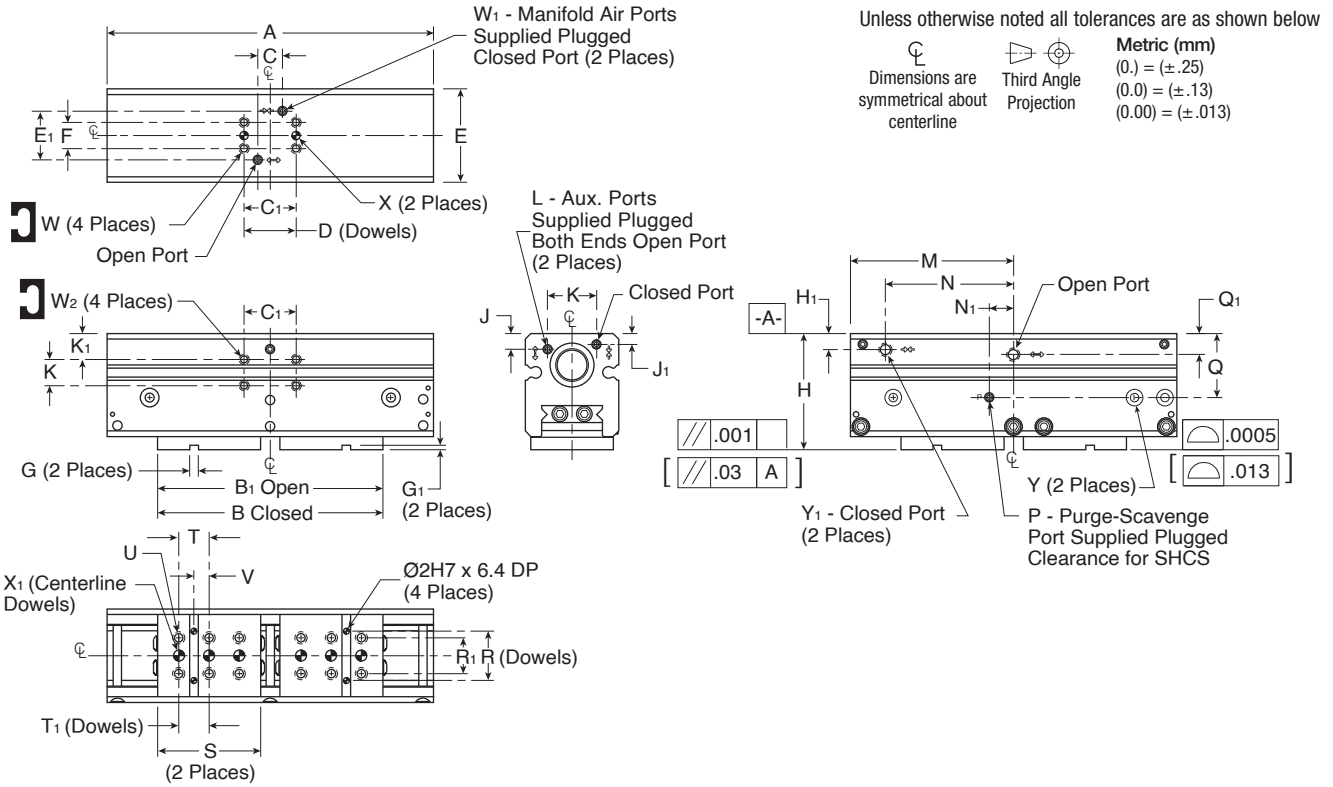

Part Number	A	B	B1	C	C1	D	E	E1	F	G	G1	H	H1	J	J1	K	K1	L	M	N	N1	P
P5GR-010***006	62.9	47	53	8.9	19.1	19.05	25.0	15.2	9.5	3.15 <sup>+0.02</sup>	1.52 <sup>+0.02</sup>	34.67 <sup>+0.02</sup>	5.8	4.4	3.8	9.5	8.5	M3 x 3 Dp	31.4	18.7	5.1	M3 x 3 Dp
P5GR-010***013	73.7	49	62	8.9	19.1	19.05	25.0	15.2	9.5	3.15 <sup>+0.02</sup>	1.52 <sup>+0.02</sup>	34.67 <sup>+0.02</sup>	5.8	4.4	3.8	9.5	8.5	M3 x 3 Dp	36.8	24.1	5.1	M3 x 3 Dp
P5GR-014***016	90.2	63	79	8.9	19.1	19.05	34.0	17.8	9.5	3.15 <sup>+0.02</sup>	1.52 <sup>+0.02</sup>	42.21 <sup>+0.02</sup>	5.8	5.7	3.9	9.5	9.5	M3 x 3 Dp	45.1	32.4	8.9	M3 x 3 Dp
P5GR-014***025	118.7	82	107	8.9	19.1	19.05	34.0	17.8	9.5	3.15 <sup>+0.02</sup>	1.52 <sup>+0.02</sup>	42.21 <sup>+0.02</sup>	5.8	5.7	3.9	9.5	9.5	M3 x 3 Dp	59.4	46.7	8.9	M3 x 3 Dp
P5GR-021***025	129	89	115	12.7	38.1	38.10	46.0	28.7	19.1	3.15 <sup>+0.02</sup>	1.52 <sup>+0.02</sup>	55.63 <sup>+0.02</sup>	5.8	7.0	5.8	19.1	9.5	M5 x 5 Dp	64.5	45.5	14.0	M5 x 5 Dp
P5GR-021***038	175.5	123	161	12.7	38.1	38.10	46.0	28.7	19.1	3.15 <sup>+0.02</sup>	1.52 <sup>+0.02</sup>	55.63 <sup>+0.02</sup>	5.8	7.0	5.8	19.1	9.5	M5 x 5 Dp	87.8	68.7	14.0	M5 x 5 Dp

Part Number	Q	Q1	R	R1	S	T	T1	U	V	W	W1	W2	X	X1	Y	Y1
P5GR-010***006	18.5	7.4	9.19	9.0	21	12	11.99	M3 x 5 Dp	6.0	M3 x 4 Dp	M3 x 3 Dp	M3 x 4 Dp	Ø3H7 x 2.5 Dp	Ø2H7 x 3.6 Dp	Ø6.35 x 3 Dp	M5 x 4 Dp
P5GR-010***013	18.5	7.4	9.20	9.0	21	12	11.99	M3 x 5 Dp	6.0	M3 x 4 Dp	M3 x 3 Dp	M3 x 4 Dp	Ø3H7 x 2.5 Dp	Ø2H7 x 3.6 Dp	Ø6.35 x 3 Dp	M5 x 4 Dp
P5GR-014***016	23.2	8.0	17.98	13.0	28	16	16.00	M4 x 7 Dp	8.0	M3 x 4 Dp	M3 x 3 Dp	M3 x 5 Dp	Ø3H7 x 2.5 Dp	Ø4H7 x 3.6 Dp	Ø6.35 x 3 Dp	M5 x 5 Dp
P5GR-014***025	23.2	8.0	17.98	13.0	37.5	11	11.00	M4 x 7 Dp	5.5	M3 x 4 Dp	M3 x 3 Dp	M3 x 5 Dp	Ø3H7 x 2.5 Dp	Ø4H7 x 3.6 Dp	Ø6.35 x 3 Dp	M5 x 5 Dp
P5GR-021***025	31.1	11.2	25.78	17.0	40.0	12.5	12.50	M5 x 10 Dp	6.2	M5 x 5 Dp	M5 x 5 Dp	M5 x 5 Dp	Ø5H7 x 3.0 Dp	Ø5H7 x 5.3 Dp	Ø6.35 x 3 Dp	M5 x 5 Dp
P5GR-021***038	31.1	11.2	25.78	17.0	58.0	16.0	16.00	M5 x 10 Dp	8.0	M5 x 5 Dp	M5 x 5 Dp	M5 x 5 Dp	Ø5H7 x 3.0 Dp	Ø5H x 5.3 Dp	Ø6.35 x 3 Dp	M5 x 5 Dp

Dimensions in millimeters

**F**

Automation Products

Grippers

Escapements

Fittings



For inventory, lead times, and kit lookup, visit [www.pdnplu.com](http://www.pdnplu.com)

## P5GU Parallel Clean Room Harsh Environment Series

- Internal components are made from hardened bearing and tool steels. External components are made from corrosion resistant materials for resistance to de-ionized water or for use in FDA and medical parts handling applications.
- Stationary and non-contacting stainless steel shields eliminate the possibility of particle generation
- Adjustable preload screws allow for adjustment of preload on roller bearings
- The body has hard-coat anodized 60 RC with PTFE impregnation
- Dual “V” roller bearings provide low friction rolling motion. Roller bearings are preloaded for maximum support and zero side play.
- Units are lubricated with a clean room grade grease
- Slip fit dowel pin holes in body
- Purge / scavenge port for extreme environments from dirty and gritty to clean room Class 10 or better
- Stainless steel screws provide protection against corrosion
- Magnetic piston standard

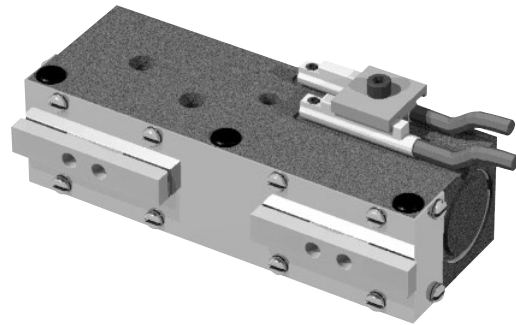

### Operating information

Operating pressure:	0.3 to 7 bar (4 to 102 PSIG)
Temperature range:	
Standard seals	-35° to 80° C (-30° to 180° F)
Fluorocarbon seals	-30° to 120° C (-20° to 248° F)
Filtration requirements:	
Air filtration	40 micron or better
Air lubrication	Not necessary*
Air humidity	Low moisture content (dry)

\*Addition of lubrication will greatly increase service life

### Ordering Information: Clean Room Harsh Environment Series

Function	Bore Size (mm)	Ports (BSP)	Stroke (mm)	Grip Force @ 7 bar (N)	Accuracy +/- mm	Repeatability +/-mm	Weight (kg)	Part Number
Double Acting Magnetic	11	M5	6.4	116	0.05	0.03	0.07	<b>P5GU-011MSG006B</b>
Double Acting Magnetic	11	M5	6.4	116	0.05	0.03	0.07	<b>P5GU-011MFG006B</b>
Double Acting Magnetic	11	M5	12.7	116	0.05	0.03	0.09	<b>P5GU-011MSG013B</b>
Double Acting Magnetic	11	M5	12.7	116	0.05	0.03	0.09	<b>P5GU-011MFG013B</b>
Double Acting Magnetic	13	M5	19.1	160	0.05	0.03	0.15	<b>P5GU-013MSG019B</b>
Double Acting Magnetic	13	M5	19.1	160	0.05	0.03	0.15	<b>P5GU-013MFG019B</b>
Double Acting Magnetic	13	M5	25.4	160	0.05	0.03	0.17	<b>P5GU-013MSG025B</b>
Double Acting Magnetic	13	M5	25.4	160	0.05	0.03	0.17	<b>P5GU-013MFG025B</b>

See Sensor section L for part numbers.

D<sup>1</sup> With linear ball bearing

D<sup>2</sup> With composite bushing

\*\* For Model 100 with 25mm stroke, A = 100.3 (3.95") and E = 28 (1.10")

**Loading information - P5GU-011\*\*\*006**

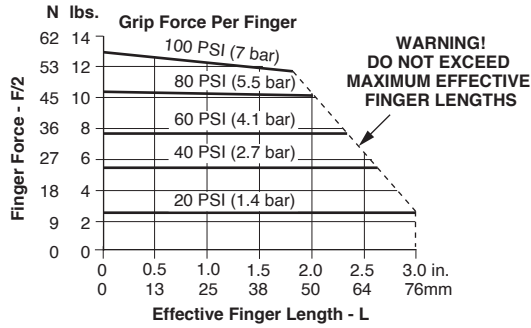

**Loading information - P5GU-013\*\*\*019**

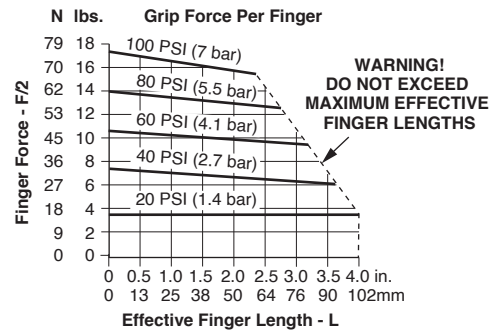

**Loading information - P5GU-011\*\*\*013**

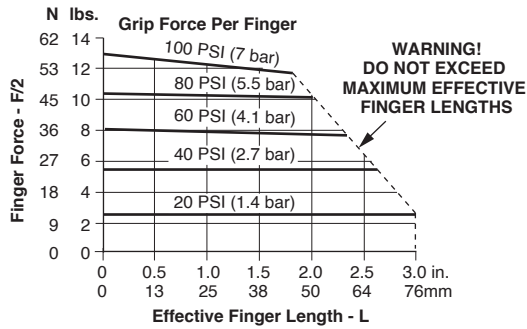

**Loading information - P5GU-013\*\*\*025**

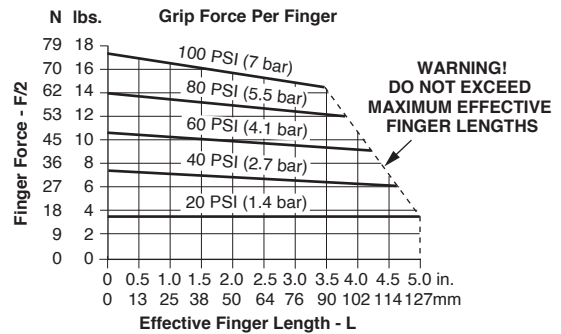

**Loading capacity† - P5GU Clean Room Harsh Environment Series**

	P5G-011***006		P5GU-011***013		P5GU-013***019		P5GU-013***025	
	Static (metric)	Dynamic (metric)	Static (metric)	Dynamic (metric)	Static (metric)	Dynamic (metric)	Static (metric)	Dynamic (metric)
Maximum Tensile T	222 N	67 N	289 N	89 N	400 N	133 N	534 N	178 N
Maximum Compressive C	222 N	67 N	289 N	89 N	400 N	133 N	534 N	178 N
Maximum Moment M <sub>x</sub>	3.4 Nm	1.1 Nm	5.1 Nm	1.7 Nm	6.8 Nm	2.3 Nm	8.5 Nm	2.8 Nm
Maximum Moment M <sub>y</sub>	4.5 Nm	1.4 Nm	6.8 Nm	2.3 Nm	9.0 Nm	2.8 Nm	11.3 Nm	4.0 Nm
Maximum Moment M <sub>z</sub>	3.4 Nm	1.1 Nm	5.1 Nm	1.7 Nm	6.8 Nm	2.3 Nm	8.5 Nm	2.8 Nm

† Capacities are per set of jaws and are not simultaneous

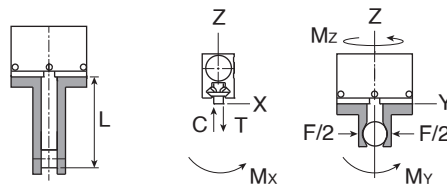

**Dimensions: P5GU Clean Room Harsh Environment Series**

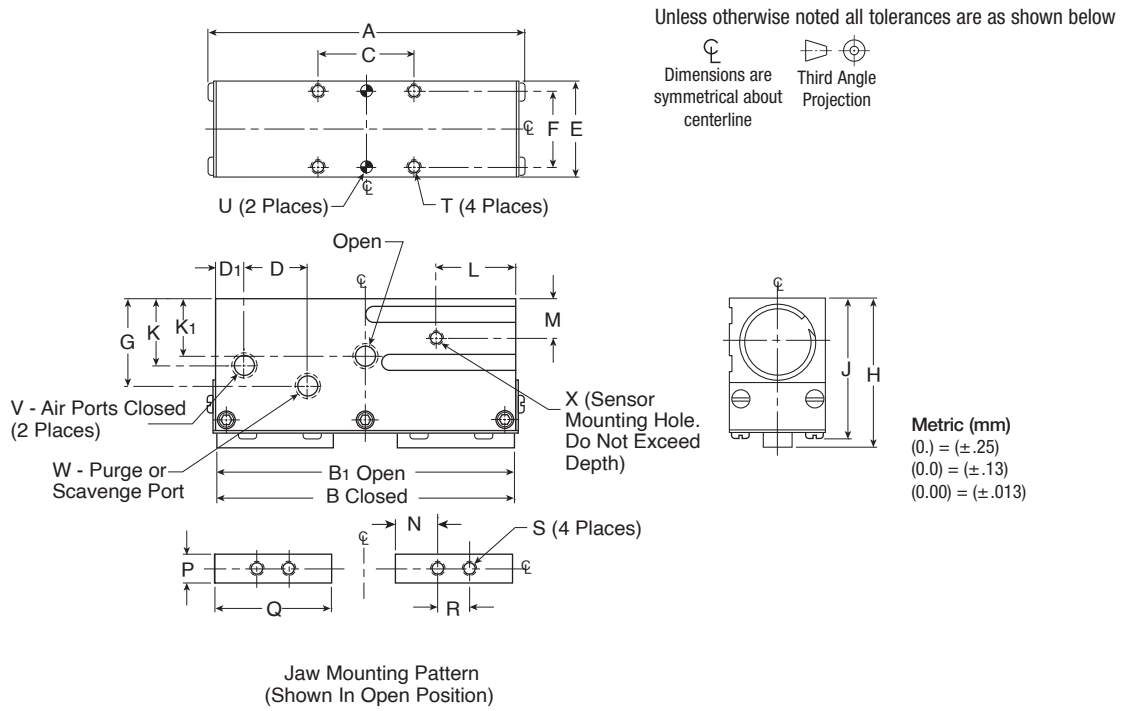

Part Number	A	B	B <sub>1</sub>	C	D	D <sub>1</sub>	E	F	G	H	J	K	K <sub>1</sub>	L	M	N	P	Q	R
<b>P5GU-011(006)</b>	48.3	38	44	19.1	8	6	19.1	15.09	17	29.5	27.8	13	11	11	8	6.4	5.69 <sup>+0.003</sup> <sub>-.003</sub>	19.1	6.4
<b>P5GU-011(013)</b>	62.9	46	59	19.1	13	6	19.0	15.09	17	29.5	27.8	13	11	16	8	8.3	5.69 <sup>+0.003</sup> <sub>-.003</sub>	23.2	6.4
<b>P5GU-013(019)</b>	83.4	63	83	25.4	14	15	22.2	16.66	18	32.6	30.3	13	11	19	8	12.7	5.69 <sup>+0.003</sup> <sub>-.003</sub>	31.8	6.4
<b>P5GU-013(025)</b>	101.8	76	101	25.4	14	24	22.2	16.66	18	32.6	30.3	13	11	25	8	15.9	5.69 <sup>+0.003</sup> <sub>-.003</sub>	38.1	6.4

Part Number	S	T	U	V	W	X
<b>P5GU-011(006)</b>	M3 x 4 Dp	M3 x 4 Dp	∅ 3 SF x 4 Dp	M5	M5	M3 x 3 Dp
<b>P5GU-011(013)</b>	M3 x 4 Dp	M3 x 4 Dp	∅ 3 SF x 4 Dp	M5	M5	M3 x 4 Dp
<b>P5GU-013(019)</b>	M3 x 4 Dp	M3 x 8 Dp	∅ 3 SF x 6 Dp	M5	M5	M3 x 4 Dp
<b>P5GU-013(025)</b>	M3 x 4 Dp	M3 x 8 Dp	∅ 3 SF x 6 Dp	M5	M5	M3 x 4 Dp

Dimensions in millimeters

**Automation Products**  
**Grippers**  
**Escapements**  
**Fittings**



For inventory, lead times, and kit lookup, visit [www.pdnplu.com](http://www.pdnplu.com)

**P5GN Series, Compact**

- One piece lightweight aircraft quality aluminum body
- The body and bottom plate have hard-coat anodize 60 RC with PTFE impregnation
- 3 standard air port locations (front, back, and top)
- Back and top air ports can be o-ring manifold sealed to eliminate air lines
- Standard mounting slots for magneto resistive (sensors sold separately)
- Slip fit dowel pin holes in body and jaws
- Jaws are supported throughout the length of the body
- Purge / scavenge port used with vacuum for clean room environments or positive pressure with harsh environments
- Jaw components made from hardened and precision ground steel for minimum jaw play with hard plating for wear resistance and long life
- Front-to-back thru counterbores for socket head cap screw mounting
- Magnetic piston standard

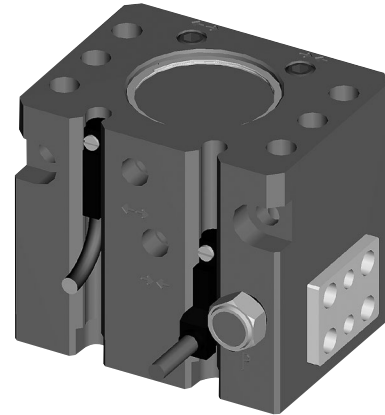

**Operating information**

Operating pressure:	1.5 to 7 bar (22 to 102 PSIG)
Temperature range:	
Nitrile seals (standard)	-35° to 80° C (-30° to 180° F)
Filtration requirements:	
Air filtration	40 micron or better
Air lubrication	Not necessary*
Air humidity	Low moisture content (dry)

\*Addition of lubrication will greatly increase service life

**Ordering Information: P5GN Compact Series**

Function	Bore Size (mm)	Ports (BSPP)	Stroke (mm)	Grip Force @ 7 bar (N)	Accuracy +/- mm	Repeatability +/-mm	Weight (kg)	Part Number
Double Acting Magnetic	12	M3	1.6	62	0.05	0.03	0.04	<b>P5GN-012MSG001B</b>
Double Acting Magnetic	12	M3	2.4	62	0.05	0.03	0.04	<b>P5GN-012MSG002B</b>
Double Acting Magnetic	12	M3	3.2	62	0.05	0.03	0.04	<b>P5GN-012MSG003B</b>
Double Acting Magnetic	14	M3	2.4	98	0.05	0.03	0.07	<b>P5GN-014MSG002B</b>
Double Acting Magnetic	14	M3	3.2	98	0.05	0.03	0.07	<b>P5GN-014MSG003B</b>
Double Acting Magnetic	14	M3	4.8	98	0.05	0.03	0.07	<b>P5GN-014MSG005B</b>
Double Acting Magnetic	22	M5	3.2	222	0.05	0.03	0.23	<b>P5GN-022MSG003B</b>
Double Acting Magnetic	22	M5	4.8	222	0.05	0.03	0.23	<b>P5GN-022MSG005B</b>
Double Acting Magnetic	22	M5	6.4	222	0.05	0.03	0.23	<b>P5GN-022MSG006B</b>
Double Acting Magnetic	32	M5	4.8	445	0.08	0.03	0.46	<b>P5GN-032MSG005B</b>
Double Acting Magnetic	32	M5	6.4	445	0.08	0.03	0.46	<b>P5GN-032MSG006B</b>
Double Acting Magnetic	32	M5	9.5	445	0.08	0.03	0.46	<b>P5GN-032MSG010B</b>

See Sensor section L for part numbers.

☐ Most popular.



For inventory, lead times, and kit lookup, visit [www.pdnplu.com](http://www.pdnplu.com)

**Loading information - P5GN-012**

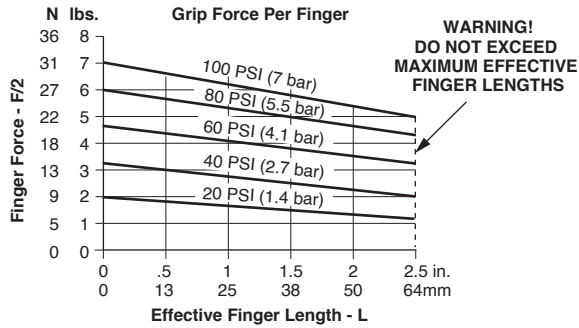

**Loading information - P5GN-022**

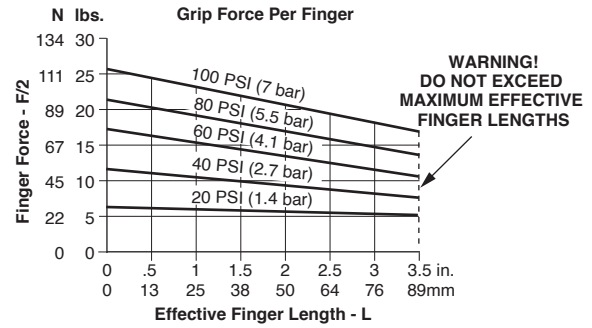

**Loading information - P5GN-014**

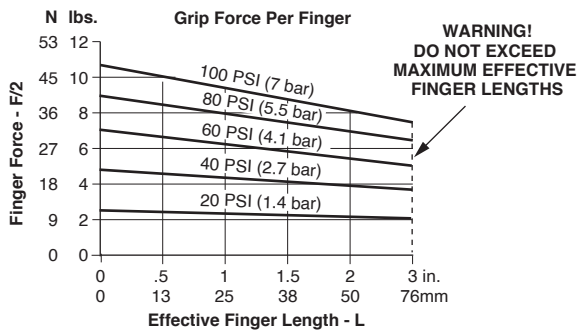

**Loading information - P5GN-032**

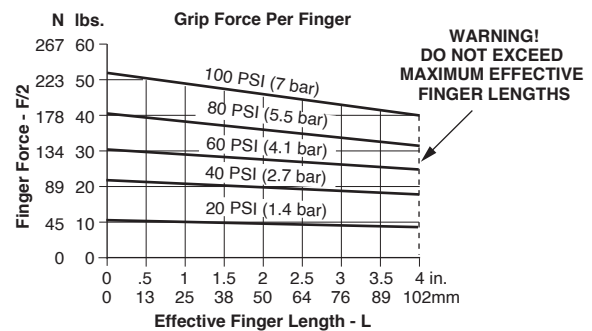

**Loading capacity† - P5GN Compact Series**

	P5GN-012		P5GN-014		P5GN-022		P5GN-032	
	Static (metric)	Dynamic (metric)	Static (metric)	Dynamic (metric)	Static (metric)	Dynamic (metric)	Static (metric)	Dynamic (metric)
Maximum Tensile T	134 N	27 N	267 N	45 N	614 N	111 N	2225 N	289 N
Maximum Compressive C	223 N	45 N	401 N	67 N	1224 N	111 N	4228 N	289 N
Maximum Moment Mx	2 Nm	0.6 Nm	5 Nm	8 Nm	14 Nm	2 Nm	48 Nm	8 Nm
Maximum Moment My	2 Nm	0.6 Nm	5 Nm	8 Nm	14 Nm	2 Nm	48 Nm	8 Nm
Maximum Moment Mz	2 Nm	0.6 Nm	5 Nm	8 Nm	14 Nm	2 Nm	48 Nm	8 Nm

† Capacities are per set of jaws and are not simultaneous

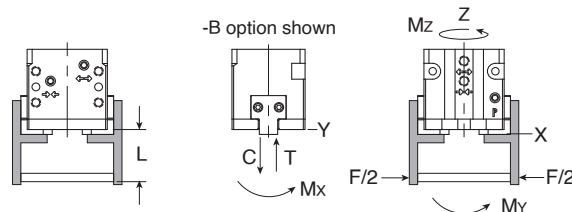

**Automation Products**  
**Grippers**  
**Escapements**  
**Fittings**



For inventory, lead times, and kit lookup, visit [www.pdnplu.com](http://www.pdnplu.com)

**Dimensions: P5GN Compact Series**

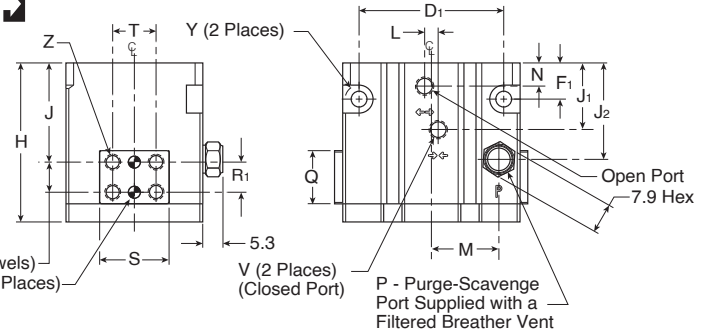
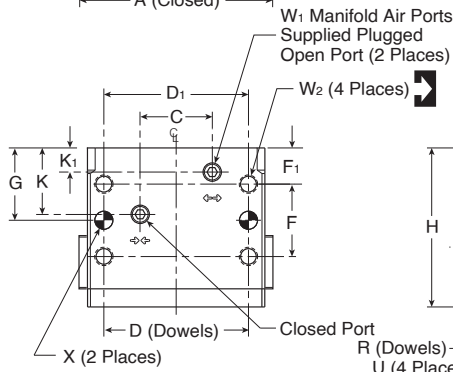
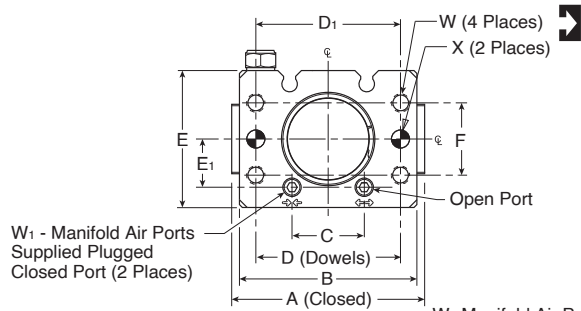

Unless otherwise noted all tolerances are as shown below

Dimensions are symmetrical about centerline  
 Third Angle Projection  
**Metric (mm)**  
 (0.) = (±.25)  
 (0.0) = (±.13)  
 (0.00) = (±.013)

Part Number	A	B	C	D	D1	E	E1	F	F1	G	H	J	J1	J2	K	K1	L	M	N	P
<b>P5GN-012</b>	28	24.4	10.2	19.05	19.1	22.2	7.9	9.5	6.7	11.4	24.4	17.6	9.7	14.7	9.7	3.6	-	9.4	3.6	M3 x 3 Dp
<b>P5GN-014</b>	35	31.2	10.2	19.05	19.1	24.1	8.6	9.5	8.0	12.7	27.4	19.9	11.2	17.0	11.2	3.6	-	11.7	3.6	M3 x 3 Dp
<b>P5GN-022</b>	51	46.7	19.1	38.10	38.1	36.1	12.7	19.1	9.5	19.1	41.9	26.1	17.5	25.4	17.5	6.1	3.6	17.8	6.1	M5 x 4 Dp
<b>P5GN-032</b>	64	59.7	22.9	38.10	38.1	43.2	16.5	19.1	12.7	22.2	51.2	31.3	19.8	30.5	19.8	6.4	4.1	22.4	6.4	M5 x 4 Dp

Part Number	Q	R	R1	S	T	U	V	W	W1	W2	X	Y	Z
<b>P5GN-012</b>	7.11 <sup>+0.00</sup> <sub>-.003</sub>	3.81	-	10.67 <sup>+0.00</sup> <sub>-.003</sub>	6.4	∅ 2.0 H7 x 3 Dp	M3 x 3 Dp	M3 x 4 Dp	M3 x 3 Dp	M3 x 4 Dp	∅ 3 H7 x 3 Dp	∅ 5 x 4 Dp C'bore (for M2.5 SHCS)	M3 x 4 Dp (4 Places)
<b>P5GN-014</b>	8.64 <sup>+0.00</sup> <sub>-.003</sub>	4.76	-	12.19 <sup>+0.00</sup> <sub>-.003</sub>	7.1	∅ 2.5 H7 x 3 Dp	M3 x 3 Dp	M3 x 4 Dp	M3 x 3 Dp	M3 x 4 Dp	∅ 3 H7 x 3 Dp	∅ 5 x 3 Dp C'bore (for M2.5 SHCS)	M4 x 5 Dp (4 Places)
<b>P5GN-022</b>	13.97 <sup>+0.00</sup> <sub>-.003</sub>	7.94	8.0	18.29 <sup>+0.00</sup> <sub>-.003</sub>	11.4	∅ 3 H7 x 5 Dp	M5 x 4 Dp	M5 x 8 Dp	M5 x 5 Dp	M5 x 6 Dp	∅ 5 H7 x 5 Dp	∅ 7 x 4 Dp C'bore (for M4 SHCS)	M4 x 6 Dp (8 Places)
<b>P5GN-032</b>	19.05 <sup>+0.00</sup> <sub>-.003</sub>	11.11	11.1	25.40 <sup>+0.00</sup> <sub>-.003</sub>	15.9	∅ 4 H7 x 6 Dp	M5 x 4 Dp	M5 x 8 Dp	M5 x 5 Dp	M5 x 6 Dp	∅ 5 H7 x 6 Dp	∅ 7 x 4 Dp C'bore (for M4 SHCS)	M5 x 8 Dp (8 Places)

Dimensions in millimeters

**F**

Automation Products

Grippers

Escapements

Fittings



For inventory, lead times, and kit lookup, visit [www.pdnplu.com](http://www.pdnplu.com)



## P5GM Parallel Series

- One piece lightweight aircraft quality aluminum body
- The body and bottom plate have hard-coat anodize 60 RC with PTFE impregnation
- 3 standard air port locations (front, back, and top)
- Back and top air ports can be o-ring manifold sealed to eliminate air lines
- Standard mounting slots for magneto resistive (sensors sold separately)
- Slip fit dowel pin holes in body and jaws
- Jaws are supported throughout the length of the body
- Purge / scavenge port used with vacuum for clean room environments or positive pressure with harsh environments
- Jaw components made from hardened and precision ground steel for minimum jaw play with hard plating for wear resistance and long life
- Front-to-back thru counterbores for socket head cap screw mounting
- Magnetic piston standard

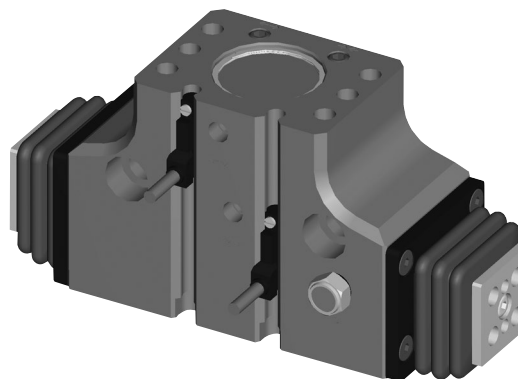

Bellows are not included with the standard part numbers shown below. If bellows are required, please contact our Applications team for more information.

### Operating information

Operating pressure:	1.5 to 7 bar (22 to 102 PSIG)
Temperature range:	
Nitrile seals (standard)	-35° to 80° C (-30° to 180° F)
Filtration requirements:	
Air filtration	40 micron or better
Air lubrication	Not necessary*
Air humidity	Low moisture content (dry)

\*Addition of lubrication will greatly increase service life

### Ordering Information: P5GM Parallel Series

Function	Bore Size (mm)	Ports (BSPP)	Stroke (mm)	Grip Force @ 7 bar (N)	Accuracy +/- mm	Repeatability +/-mm	Weight (kg)	Part Number
Double Acting Magnetic	10	M3	4.8	62	0.05	0.03	0.04	<b>P5GM-010MSG005B</b>
Double Acting Magnetic	10	M3	6.4	62	0.05	0.03	0.04	<b>P5GM-010MSG006B</b>
Double Acting Magnetic	10	M3	9.5	62	0.05	0.03	0.04	<b>P5GM-010MSG010B</b>
Double Acting Magnetic	14	M3	6.4	98	0.05	0.03	0.14	<b>P5GM-014MSG006B</b>
Double Acting Magnetic	14	M3	9.5	98	0.05	0.03	0.14	<b>P5GM-014MSG010B</b>
Double Acting Magnetic	14	M3	12.7	98	0.05	0.03	0.14	<b>P5GM-014MSG013B</b>
Double Acting Magnetic	22	M5	9.5	222	0.05	0.03	0.43	<b>P5GM-022MSG010B</b>
Double Acting Magnetic	22	M5	12.7	222	0.05	0.03	0.43	<b>P5GM-022MSG013B</b>
Double Acting Magnetic	22	M5	19.1	222	0.05	0.03	0.43	<b>P5GM-022MSG019B</b>
Double Acting Magnetic	32	M5	12.7	445	0.08	0.03	0.90	<b>P5GM-032MSG013B</b>
Double Acting Magnetic	32	M5	19.1	445	0.08	0.03	0.90	<b>P5GM-032MSG019B</b>
Double Acting Magnetic	32	M5	25.4	445	0.08	0.03	0.90	<b>P5GM-032MSG032B</b>

See Sensor section L for part numbers.

**Automation Products**  
**Grippers**  
**Escapements**  
**Fittings**



For inventory, lead times, and kit lookup, visit [www.pdnplu.com](http://www.pdnplu.com)



**Loading information - P5GM-010**

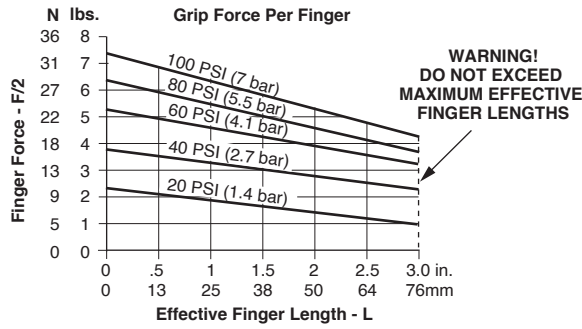

**Loading information - P5GM-022**

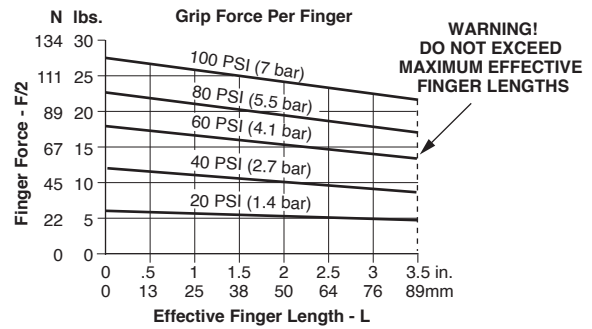

**Loading information - P5GM-014**

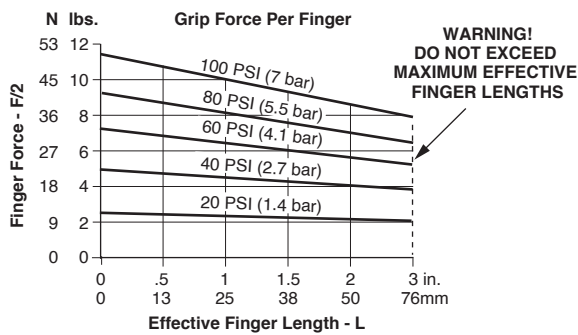

**Loading information - P5GM-032**

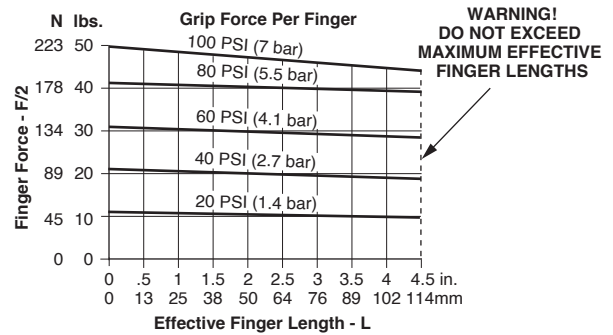

**Loading capacity† - P5GM Parallel Series**

	P5GM-010		P5GM-014		P5GM-022		P5GM-032	
	Static (metric)	Dynamic (metric)	Static (metric)	Dynamic (metric)	Static (metric)	Dynamic (metric)	Static (metric)	Dynamic (metric)
Maximum Tensile T	445 N	67 N	556 N	111 N	1558 N	178 N	3004 N	401 N
Maximum Compressive C	668 N	111 N	1113 N	111 N	2893 N	178 N	5785 N	401 N
Maximum Moment Mx	10 Nm	2 Nm	13 Nm	2 Nm	28 Nm	5 Nm	73 Nm	12 Nm
Maximum Moment My	10 Nm	2 Nm	13 Nm	2 Nm	28 Nm	5 Nm	73 Nm	12 Nm
Maximum Moment Mz	10 Nm	2 Nm	13 Nm	2 Nm	28 Nm	5 Nm	73 Nm	12 Nm

† Capacities are per set of jaws and are not simultaneous

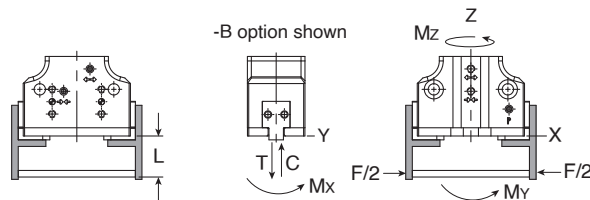

**Dimensions: P5GM Parallel Series**

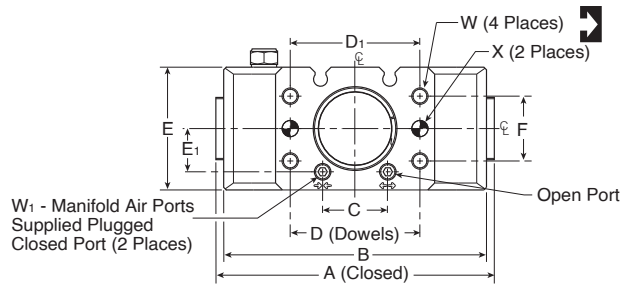

Unless otherwise noted all tolerances are as shown below

Dimensions are symmetrical about centerline  
 Third Angle Projection  
**Metric (mm)**  
 (0.) = (±.25)  
 (0.0) = (±.13)  
 (0.00) = (±.013)

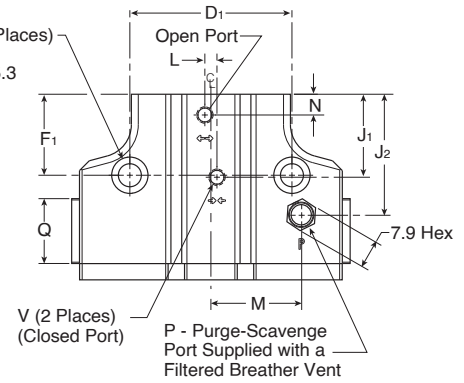
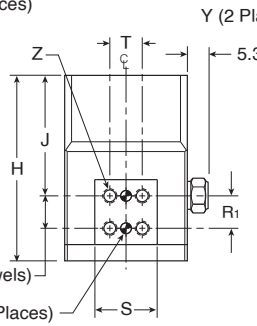
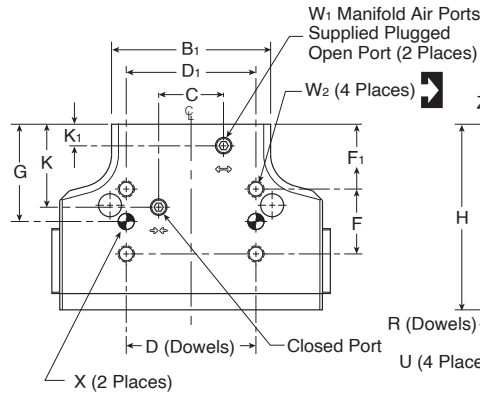

Part Number	A	B	B <sub>1</sub>	C	D	D <sub>1</sub>	E	E <sub>1</sub>	F	F <sub>1</sub>	G	H	J	J <sub>1</sub>	J <sub>2</sub>	K	K <sub>1</sub>	L	M	N	P
<b>P5GM-010</b>	45	41.4	24.4	10.2	19.05	19.1	22.2	7.9	9.5	12.7	17.5	30.7	22.4	13.5	20.3	13.5	3.6	-	14.7	3.6	M3 x 3 Dp
<b>P5GM-014</b>	56	52.6	31.2	10.2	19.05	19.1	24.1	8.6	9.5	15.8	20.6	36.2	26.6	15.7	23.4	15.7	3.6	-	17.3	3.6	M3 x 3 Dp
<b>P5GM-022</b>	82	77.2	46.7	19.1	38.10	38.1	36.1	12.7	19.1	19.1	28.6	54.5	35.4	24.4	35.6	24.4	6.1	3.6	26.7	6.1	M5 x 4 Dp
<b>P5GM-032</b>	103	98.8	59.7	22.9	38.10	38.1	43.2	16.5	19.1	28.6	38.1	67.0	41.6	29.2	43.2	29.2	6.4	4.1	35.1	6.4	M5 x 4 Dp

Part Number	Q	R	R <sub>1</sub>	S	T	U	V	W	W <sub>1</sub>	W <sub>2</sub>	X	Y	Z
<b>P5GM-010</b>	10.67 <sup>+0.003</sup> <sub>-0.003</sub>	4.76	-	10.67 <sup>+0.000</sup> <sub>-0.000</sub>	6.4	∅ 2.0 H7 x 3 Dp	M3 x 3 Dp	M3 x 4 Dp	M3 x 3 Dp	M3 x 4 Dp	∅ 3 H7 x 3 Dp	∅ 7 x 4 Dp C'bore (for M4 SHCS)	M3 x 4 Dp (4 Places)
<b>P5GM-014</b>	12.70 <sup>+0.000</sup> <sub>-0.000</sub>	4.76	-	12.19 <sup>+0.000</sup> <sub>-0.000</sub>	7.1	∅ 2.5 H7 x 3 Dp	M3 x 3 Dp	M3 x 4 Dp	M3 x 3 Dp	M3 x 4 Dp	∅ 3 H7 x 3 Dp	∅ 7 x 4 Dp C'bore (for M4 SHCS)	M4 x 5 Dp (4 Places)
<b>P5GM-022</b>	19.05 <sup>+0.000</sup> <sub>-0.000</sub>	9.53	9.5	18.29 <sup>+0.000</sup> <sub>-0.000</sub>	9.5	∅ 3 H7 x 5 Dp	M5 x 3Dp	M5 x 8 Dp	M5 x 5 Dp	M5 x 6 Dp	∅ 5 H7 x 5 Dp	∅ 11 x 7 Dp C'bore (for M6 SHCS)	M4 x 6 Dp (8 Places)
<b>P5GM-032</b>	25.40 <sup>+0.000</sup> <sub>-0.000</sub>	15.88	15.9	25.40 <sup>+0.000</sup> <sub>-0.000</sub>	15.9	∅ 4 H7 x 6 Dp	M5 x 4 Dp	M5 x 8 Dp	M5 x 5 Dp	M5 x 6 Dp	∅ 5 H7 x 5 Dp	∅ 11 x 7 Dp C'bore (for M6 SHCS)	M5 x 8 Dp (8 Places)

Dimensions in millimeters

**E**  
 Automation Products  
**Grippers**  
 Escapements  
 Fittings



For inventory, lead times, and kit lookup, visit [www.pdnplu.com](http://www.pdnplu.com)

## P5GS Parallel Wide Body Series

- C-bores on inside of jaws for thru mounting to increase range of applications
- Standard sensor mounting slots for magneto resistive and inductive sensors (sensors sold separately)
- End of stroke cushions reduce shock of fully open and close strokes
- Each jaw is supported by 2 shafts that extend the entire length of the body and are guided by 2 oil impregnated bronze bushings per shaft
- Hardened precision stainless steel shafting for wear resistance and long life
- Magneto resistive sensors are an alternative option to inductive sensors (magnets supplied standard)
- Top air ports can be o-ring manifold sealed to eliminate air lines
- 2 standard air port locations (front and top)
- Slip fit dowel pin holes in body and jaws
- Large jaw configuration allows for simplified finger mounting

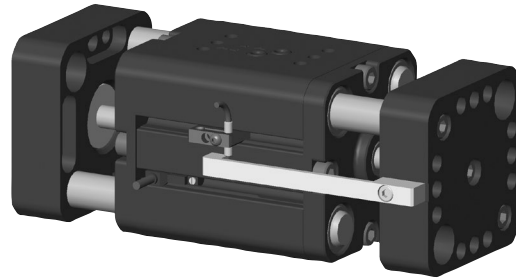

### Operating information

Operating pressure:	3 to 7 bar (44 to 102 PSIG)
Temperature range:	
Nitrile seals (Standard)	-35° to 80° C (-30° to 180° F)
Filtration requirements:	
Air filtration	40 micron or better
Air lubrication	Not necessary*
Air humidity	Low moisture content (dry)

\*Addition of lubrication will greatly increase service life

### Ordering Information: P5GS Wide Body Series

Function	Bore Size (mm)	Ports (BSPP)	Stroke (mm)	Grip Force @ 7 bar (N)	Accuracy +/- mm	Repeatability +/-mm	Weight (kg)	Part Number
Double acting magnetic	16	M3	19.1	222	0.08	0.03	0.30	<b>P5GS-016MSG019B</b>
Double acting magnetic	16	M3	31.8	222	0.08	0.03	0.39	<b>P5GS-016MSG032B</b>
Double acting magnetic	24	M5	25.4	445	0.08	0.03	0.81	<b>P5GS-024MSG025B</b>
Double acting magnetic	24	M5	50.8	445	0.08	0.03	1.20	<b>P5GS-024MSG051B</b>
Double acting magnetic	32	M5	38.1	800	0.08	0.03	1.48	<b>P5GS-032MSG038B</b>
Double acting magnetic	32	M5	63.5	800	0.08	0.03	2.0	<b>P5GS-032MSG074B</b>

See Sensor section L for part numbers.

☐ Most popular.



For inventory, lead times, and kit lookup, visit [www.pdnplu.com](http://www.pdnplu.com)

**Loading information - P5GS-016MSG019B**

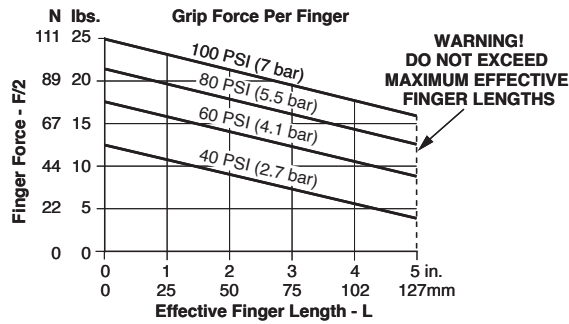

**Loading information - P5GS-024MSG051B**

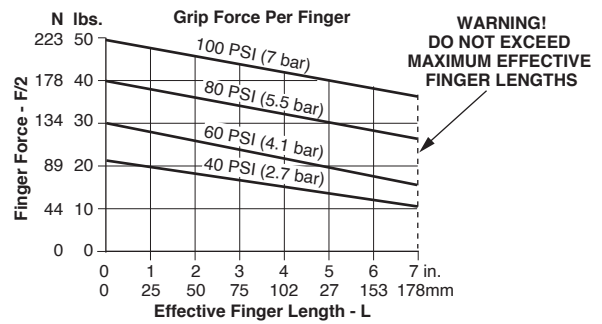

**Loading information - P5GS-016MSG032B**

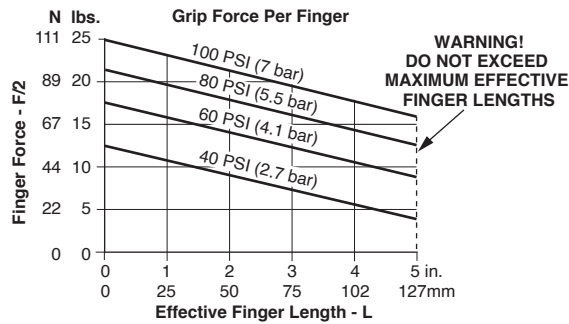

**Loading information - P5GS-032MSG038B**

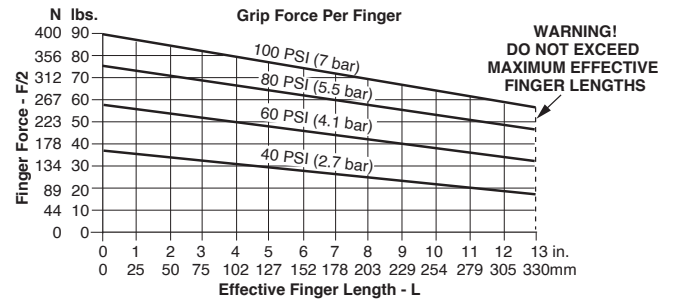

**Loading information - P5GS-024MSG025B**

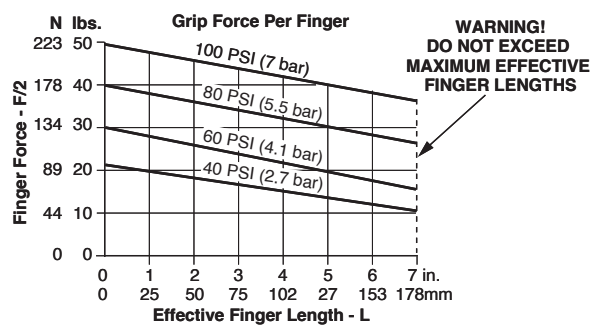

**Loading information - P5GS-032MSG074B**

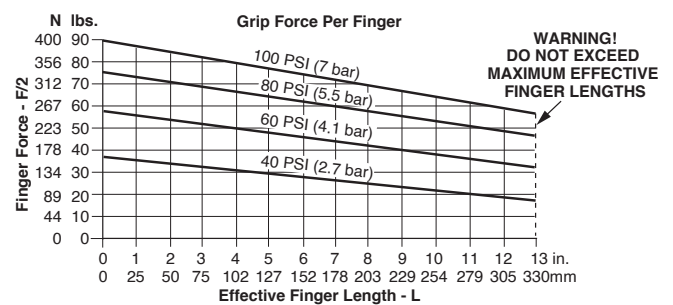

**Loading capacity† - P5GS Wide Body Series**

	P5GS-016M***19B		P5GS-016M***32B		P5GS-024M***25B		P5GS-024M***51B		P5GS-032M***38B		P5GS-032M***74B	
	Static (metric)	Dynamic (metric)	Static (metric)	Dynamic (metric)	Static (metric)	Dynamic (metric)	Static (metric)	Dynamic (metric)	Static (metric)	Dynamic (metric)	Static (metric)	Dynamic (metric)
Maximum Tensile T	267 N	53 N	267 N	53 N	534 N	107 N	534 N	107 N	2668 N	267 N	2668 N	267 N
Maximum Compressive C	267 N	53 N	267 N	53 N	534 N	107 N	534 N	107 N	2668 N	267 N	2668 N	267 N
Maximum Moment Mx	14 Nm	3 Nm	14 Nm	3 Nm	24 Nm	5 Nm	24 Nm	5 Nm	68 Nm	7 Nm	68 Nm	7 Nm
Maximum Moment My	20 Nm	4 Nm	20 Nm	4 Nm	34 Nm	7 Nm	34 Nm	7 Nm	102 Nm	10 Nm	102 Nm	10 Nm
Maximum Moment Mz	14 Nm	3 Nm	14 Nm	3 Nm	24 Nm	5 Nm	24 Nm	5 Nm	68 Nm	7 Nm	68 Nm	7 Nm

† Capacities are per set of jaws and are not simultaneous

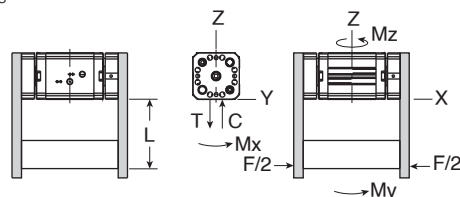

**Dimensions: P5GS Wide Body Series**

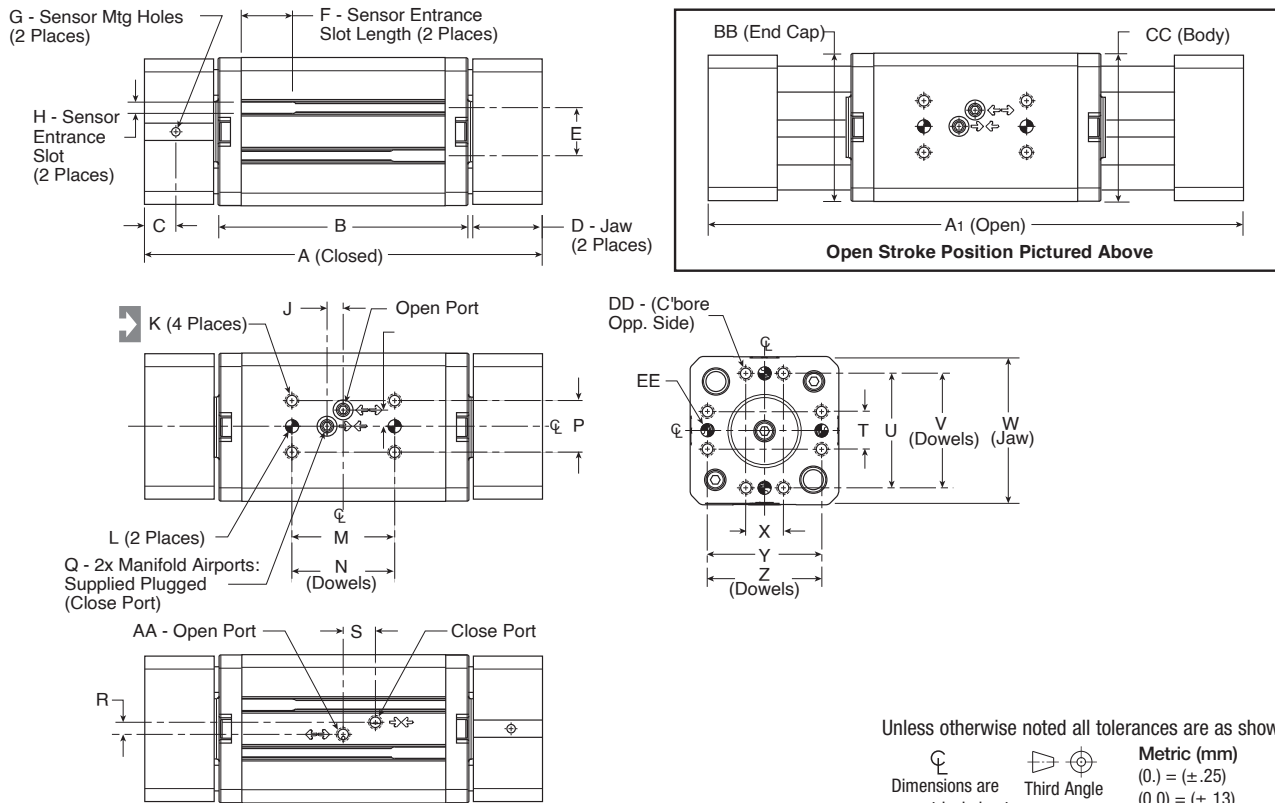

Part Number	A	A <sub>1</sub>	B	C	D	E	F	G	H	J	K	L	M	N	P	Q
<b>P5GS-016MSG019B</b>	79	98	54.4	5.8	10.5	7.9	19.1	M3 x 3 Dp	4.2	4	M3 x 5 Dp	∅ 3h7 x 5 Dp	19.0	19.05	9.5	M3 x 5 Dp
<b>P5GS-016MSG032B</b>	104	136	67.1	7.3	16.9	7.9	19.1	M3 x 3 Dp	4.2	4	M3 x 5 Dp	∅ 3h7 x 5 Dp	19.1	19.05	9.5	M3 x 5 Dp
<b>P5GS-024MSG025B</b>	97	122	67.1	6.7	13.0	17.8	19.1	M3 x 4 Dp	4.2	6	M5 x 7 Dp	∅ 5h7 x 5 Dp	38.1	38.10	19.1	M5 x 7 Dp
<b>P5GS-024MSG051B</b>	147	198	92.5	11.7	25.7	17.8	19.1	M3 x 4 Dp	4.2	6	M5 x 7 Dp	∅ 5h7 x 5 Dp	38.1	38.10	19.1	M5 x 7 Dp
<b>P5GS-032MSG038B</b>	125	164	82.8	12.1	19.2	18.8	19.1	M3 x 4 Dp	4.2	6	M5 x 8 Dp	∅ 5h7 x 5 Dp	38.1	38.10	19.1	M5 x 5 Dp
<b>P5GS-032MSG074B</b>	177	240	108.2	14.9	39.1	18.8	19.1	M3 x 4 Dp	4.2	6	M5 x 8 Dp	∅ 5h7 x 5 Dp	38.1	38.10	19.1	M5 x 7 Dp

Part Number	R	S	T	U	V	W	X	Y	Z	AA	BB	CC	DD	EE
<b>P5GS-016MSG019B</b>	6	10	10.0	30.0	30.00	37.6	10.0	30.0	30.00	M5 x 5 Dp	37.6	38.0	M4 x 8 Dp	∅ 4h7 x 5 Dp
<b>P5GS-016MSG032B</b>	6	12	10.0	30.0	30.00	37.6	10.0	30.0	30.00	M5 x 5 Dp	37.6	38.0	M4 x 8 Dp	∅ 4h7 x 5 Dp
<b>P5GS-024MSG025B</b>	5	11	14.0	42.5	42.50	54.0	14.0	42.5	42.50	M5 x 6 Dp	54.7	55.0	M5 x 10 Dp	∅ 5h7 x 5 Dp
<b>P5GS-024MSG051B</b>	5	12	14.0	42.5	42.50	54.0	14.0	42.5	42.50	M5 x 6 Dp	54.7	55.0	M5 x 10 Dp	∅ 5h7 x 5 Dp
<b>P5GS-032MSG038B</b>	5	15	18.0	51.0	51.00	63.0	18.0	51.0	51.00	M5 x 6 Dp	63.7	64.0	M6 x 13 Dp	∅ 6h7 x 8 Dp
<b>P5GS-032MSG074B</b>	5	15	18.0	51.0	51.00	63.0	18.0	51.0	51.00	M5 x 6 Dp	63.7	64.0	M6 x 13 Dp	∅ 6h7 x 8 Dp

Dimensions in millimeters



For inventory, lead times, and kit lookup, visit [www.pdnplu.com](http://www.pdnplu.com)

## P5GT Parallel Double Wedge Series

- Extremely compact and robust package
- One piece 7075 -T6 aircraft quality aluminum body
- Dynamic components are hardened for wear resistance and long life
- Accessory mounting holes mount sensors to unit
- Slip fit dowel pin holes in body and jaws
- Jaws are supported throughout the length of the body and are precision ground for minimal jaw play
- A double acting piston is connected by a shaft to a double sided wedge
- The wedge slides in a slot located in each of the jaws converting vertical motion of the wedge into horizontal synchronous motion of the jaws
- The large surface area of the wedge minimizes frictional wear
- Magnetic piston standard



### Operating information

Operating pressure:	3 to 7 bar (44 to 102 PSIG)
Temperature range:	
Nitrile seals (standard)	-35° to 80° C (-30° to 180° F)
Fluorocarbon seals (optional)	-30° to 150° C (-20° to 300° F)
Filtration requirements:	
Air filtration	40 micron or better
Air lubrication	Not necessary*
Air humidity	Low moisture content (dry)

\*Addition of lubrication will greatly increase service life

### Ordering Information: P5GT Double Wedge Series

Function	Bore Size (mm)	Ports (BSPP)	Stroke (mm)	Grip Force @ 7 bar (N)	Accuracy +/- mm	Repeatability +/-mm	Weight (kg)	Part Number
Double Acting Magnetic, Nitrile	25	M5	6.4	178	0.05	0.03	0.12	<b>P5GT-025MSG006B</b>
Double Acting Magnetic, Fluorocarbon	25	M5	6.4	178	0.05	0.03	0.12	<b>P5GT-025MFG006B</b>
Double Acting Magnetic, Nitrile	25	M5	9.5	178	0.05	0.03	0.25	<b>P5GT-025MSG010B</b>
Double Acting Magnetic, Fluorocarbon	25	M5	9.5	178	0.05	0.03	0.25	<b>P5GT-025MFG010B</b>
Double Acting Magnetic, Nitrile	32	M5	12.7	311	0.05	0.03	0.57	<b>P5GT-032MSG013B</b>
Double Acting Magnetic, Fluorocarbon	32	M5	12.7	311	0.05	0.03	0.57	<b>P5GT-032MFG013B</b>
Double Acting Magnetic, Nitrile	46	1/8	19.1	979	0.08	0.03	1.0	<b>P5GT-046MSG019B</b>
Double Acting Magnetic, Fluorocarbon	46	1/8	19.1	979	0.08	0.03	1.0	<b>P5GT-046MFG019B</b>
Double Acting Magnetic, Nitrile	64	1/8	31.8	1779	0.08	0.03	3.5	<b>P5GT-064MSG032B</b>
Double Acting Magnetic, Fluorocarbon	64	1/8	31.8	1779	0.08	0.03	3.5	<b>P5GT-064MFG032B</b>
Double Acting Magnetic, Nitrile	89	1/4	50.8	2669	0.08	0.03	9.5	<b>P5GT-089MSG051B</b>
Double Acting Magnetic, Fluorocarbon	89	1/4	50.8	2669	0.08	0.03	9.5	<b>P5GT-089MFG051B</b>

See Sensor section L for part numbers.

Most popular.

**E**  
 Automation Products  
 Grippers  
 Escapements  
 Fittings



For inventory, lead times, and kit lookup, visit [www.pdnplu.com](http://www.pdnplu.com)

**Loading information - P5GT-025/006**

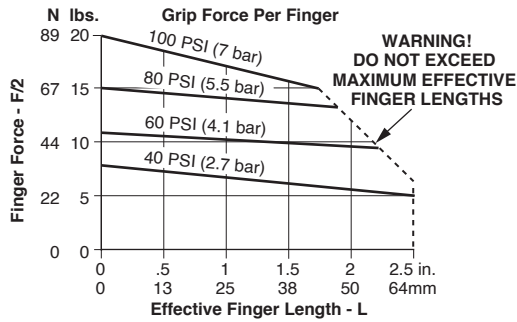

**Loading information - P5GT-046**

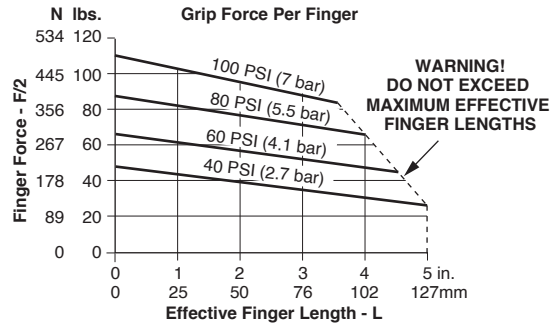

**Loading information - P5GT-025/010**

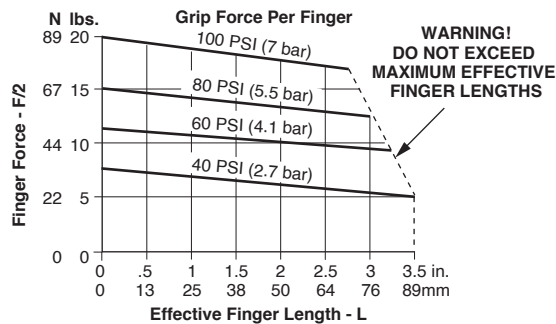

**Loading information - P5GT-064**

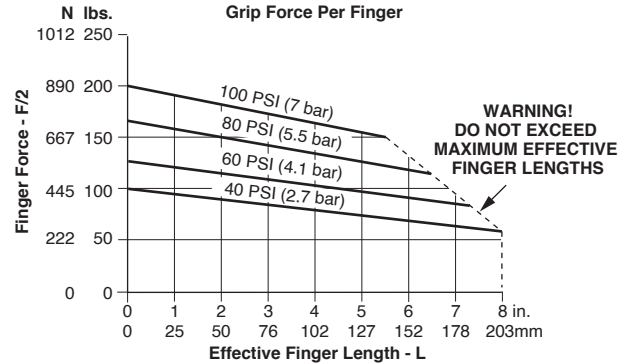

**Loading information - P5GT-032**

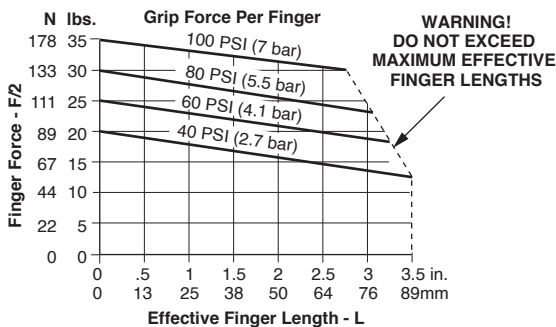

**Loading information - P5GT-089**

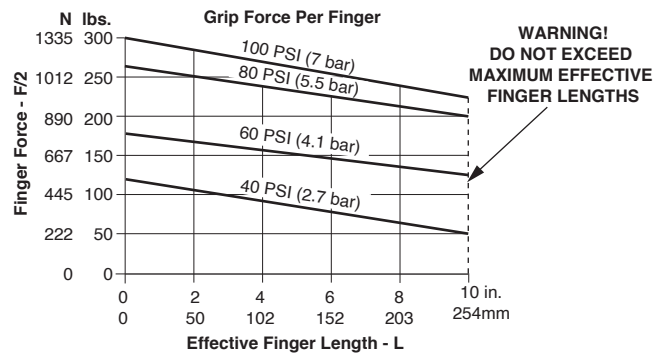

**Loading capacity† - P5GT Double Wedge Series**

	P5GT-025(006)		P5GT-025(010)		P5GT-032		P5GT-046		P5GT-064		P5GT-089	
	Static (metric)	Dynamic (metric)	Static (metric)	Dynamic (metric)	Static (metric)	Dynamic (metric)	Static (metric)	Dynamic (metric)	Static (metric)	Dynamic (metric)	Static (metric)	Dynamic (metric)
Maximum Tensile T	445 N	111 N	890 N	111 N	1779 N	222 N	3336 N	445 N	6672 N	1112 N	13345 N	1334 N
Maximum Compressive C	890 N	111 N	1779 N	111 N	3336 N	222 N	6672 N	445 N	13345 N	1112 N	26689 N	1334 N
Maximum Moment Mx	11 Nm	2 Nm	17 Nm	3 Nm	34 Nm	6 Nm	85 Nm	14 Nm	170 Nm	28 Nm	565 Nm	56 Nm
Maximum Moment My	11 Nm	2 Nm	17 Nm	3 Nm	34 Nm	6 Nm	85 Nm	14 Nm	170 Nm	28 Nm	565 Nm	56 Nm
Maximum Moment Mz	11 Nm	2 Nm	17 Nm	3 Nm	34 Nm	6 Nm	85 Nm	14 Nm	170 Nm	28 Nm	565 Nm	56 Nm

† Capacities are per set of jaws and are not simultaneous

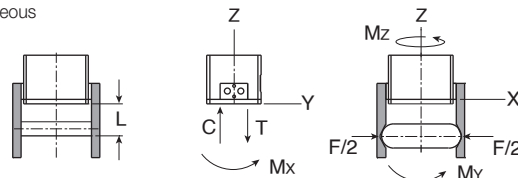

For inventory, lead times, and kit lookup, visit [www.pdnplu.com](http://www.pdnplu.com)



**Dimensions: P5GT Double Wedge Series**

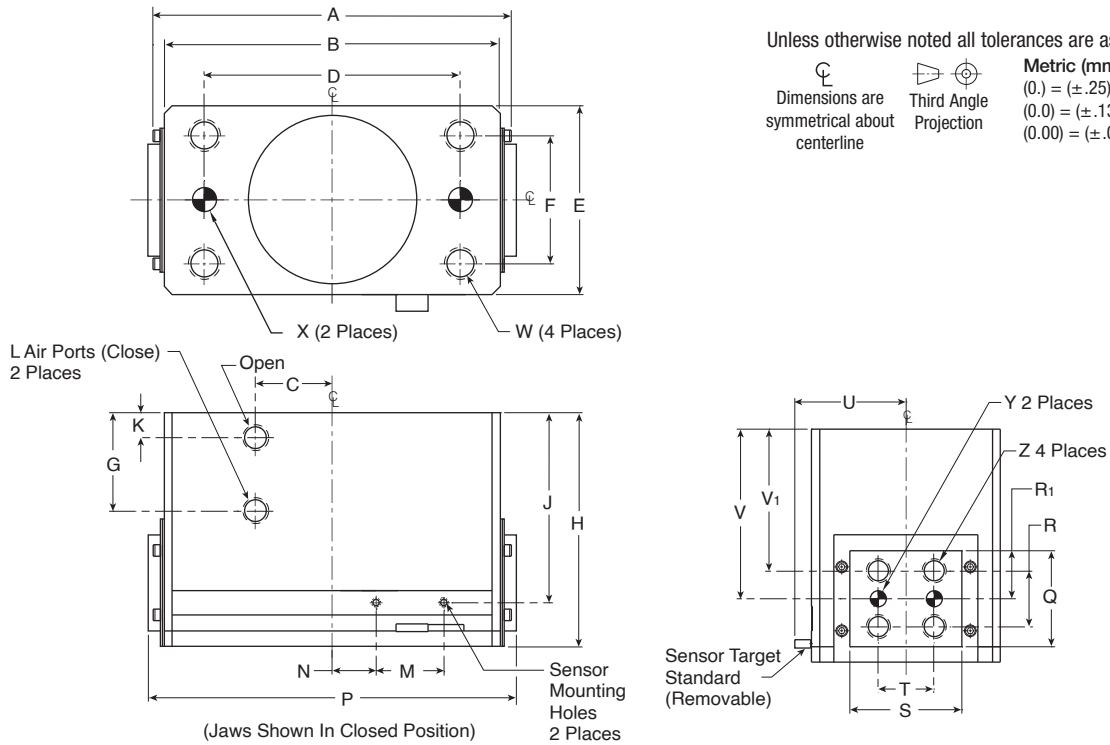

Part Number	A	B	C	D	E	F	G	H	J	K	L	M	N	P	Q
<b>P5GT-025(006)</b>	-	38.1	20	31.75	31.8	12.70	17	28.6	9	5	M5	25	-	Open 48 Closed 41	9.55 <sup>+0.00</sup> / <sub>-.003</sub>
<b>P5GT-025(010)</b>	-	50.8	23	38.10	38.1	25.40	12	35.6	14	9	M5	14	6	Open 63 Closed 54	12.34 <sup>+0.00</sup> / <sub>-.003</sub>
<b>P5GT-032</b>	70.4	63.50	30	50.80	41.3	19.05	14.4	47.3	18	7	M5	17	3	Open 81 Closed 68	18.69 <sup>+0.00</sup> / <sub>-.003</sub>
<b>P5GT-046</b>	89.6	82.55	25	63.50	54.0	25.40	25	61.9	46	8	G1/8	27	5	Open 108 Closed 85	25.43 <sup>+0.00</sup> / <sub>-.003</sub>
<b>P5GT-064</b>	142.2	133.35	-	101.60	74.9	50.8	39	92.8	75	10	G1/8	27	17	Open 177 Closed 146	38.10 <sup>+0.00</sup> / <sub>-.003</sub>
<b>P5GT-089</b>	214.7	203.20	-	152.40	100.3	69.9	47	118.2	98	11	G1/4	56	25	Open 266 Closed 216	47.63 <sup>+0.00</sup> / <sub>-.003</sub>

Part Number	R	S	T	U	V	W	X	Y	Z	Z <sub>1</sub>
<b>P5GT-025(006)</b>	6.35	15.88 <sup>+0.00</sup> / <sub>-.003</sub>	7.9	22.2	21.5	M4 x 9 Dp	Ø 3H7 x 6 Dp	Ø 2H7 x 4 Dp	M4 x 4.7 Dp	M3 x 4 Dp
<b>P5GT-025(010)</b>	7.95	18.67 <sup>+0.00</sup> / <sub>-.003</sub>	12.7	25.4	26.3	M6 x 12 Dp	Ø 5H7 x 6 Dp	Ø 2.5H7 x 4 Dp	M4 x 7 Dp	M3 x 4 Dp
<b>P5GT-032</b>	9.53	25.01 <sup>+0.00</sup> / <sub>-.003</sub>	17.5	27.0	28.5	M6 x 12 Dp	Ø 5H7 x 6 Dp	Ø 4H7 x 4 Dp	M5 x 9 Dp	M3 x 4 Dp
<b>P5GT-046</b>	12.70	31.78 <sup>+0.00</sup> / <sub>-.003</sub>	19.1	33.3	38.1	M10 x 19 Dp	Ø 6H7 x 12 Dp	Ø 5H7 x 9 Dp	M6 x 12 Dp	M3 x 6 Dp
<b>P5GT-064</b>	22.2	44.48 <sup>+0.00</sup> / <sub>-.003</sub>	22.23	44.2	67.4	M12 x 25 Dp	Ø 10H8 x 12 Dp	Ø 8H7 x 12 Dp	M10 x 19 Dp	M3 x 9 Dp
<b>P5GT-089</b>	28.57	57.10 <sup>+0.00</sup> / <sub>-.003</sub>	34.9	56.9	70.7	M20 x 38 Dp	Ø 12H8 x 19 Dp	Ø 6H7 x 12 Dp	M12 x 28 Dp	M3 x 9 Dp

Dimensions in millimeters

Automation Products  
 Grippers  
 Escapements  
 Fittings



For inventory, lead times, and kit lookup, visit [www.pdnplu.com](http://www.pdnplu.com)



**Features**

**P5GP Electric Series**

- One piece, lightweight aircraft quality aluminum body ensures product accuracy
- The body and jaws are hard-coat anodized to 60 RC with PTFE impregnation
- Ridged design and full body support of the jaws allows for long finger lengths
- Versatile mounting on top, side front and back of body.
- IP54 rating for tough application environments
- Slip fit dowel pin holes located in body and jaws for precision mounting
- Precision rack and pinion drive components for smooth actuation. Zero backlash while gripping ensures excellent repeatability and accuracy.
- Built in electronics, no external control board needed
- Magnetic piston standard

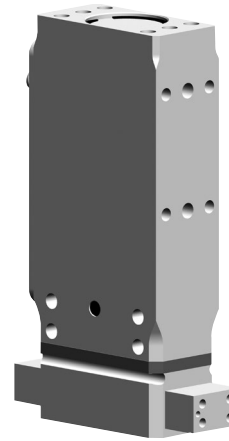

Operating information	
Voltage:	24VDC
Power Req. @ 100% Duty Cycle:	4.2 Watts
Current - Peak:	1.5 Amps Max.
Current - Continuous:	0.175 Amps
Temperature range:	5° to 60° C (41° to 140° F)

**Ordering Information: P5GP Electric Gripper Series**

Function	Stroke (mm)	Grip Force (N)	Accuracy +/- mm	Repeatability +/-mm	Weight (kg)	Part Number
Electric	25	111	0.051	0.025	0.53	<b>P5GP-000ESX025B</b>

See Sensor section L for part numbers.

**Electrical Interface**

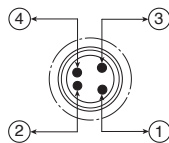

Pin Out (Looking Into Header Connector On Gripper)

- 1 ..... Brown (+ 24 VDC)
- 2 ..... White (Open Gripper) +24 VDC = Active
- 3 ..... Blue (Ground)
- 4 ..... Black (Close Gripper) +24 VDC = Active

**4-Wire Power & Signal Cable: P8S-CABL-046**

Most popular.



For inventory, lead times, and kit lookup, visit [www.pdnplu.com](http://www.pdnplu.com)

**Loading information - P5GP-000**

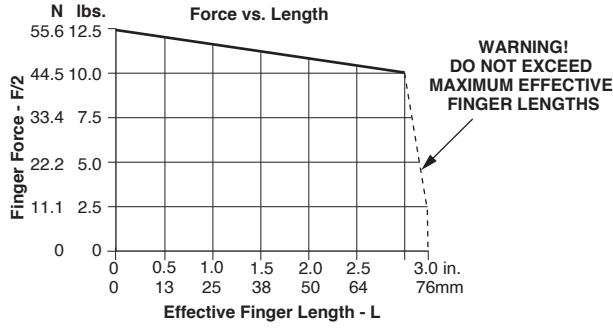

**Loading capacity† - P5GP Electric Gripper**

	Static (metric)
Maximum Tensile T	10 N
Maximum Compressive C	10 N
Maximum Moment Mx	14 Nm
Maximum Moment My	17 Nm
Maximum Moment Mz	14 Nm

† Capacities are per set of jaws and are not simultaneous

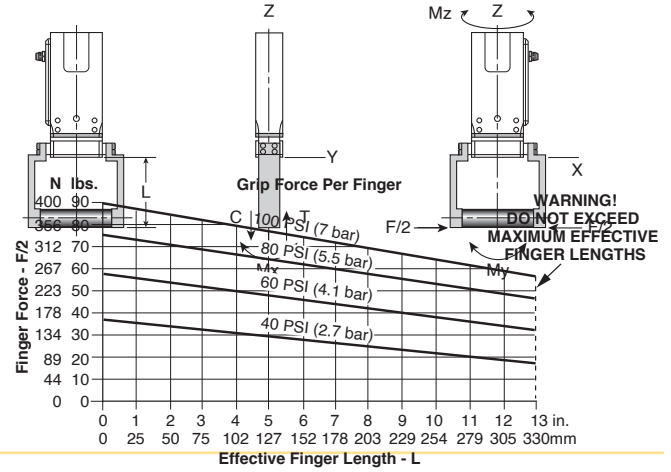

**Dimensions: P5GP Electric Gripper Series**

Unless otherwise noted all tolerances are as shown below

Third Angle Projection  
 Dimensions are symmetrical about centerline  
**Metric (mm)**  
 (0.) = (±.25)  
 (0.0) = (±.13)  
 (0.00) = (±.013)

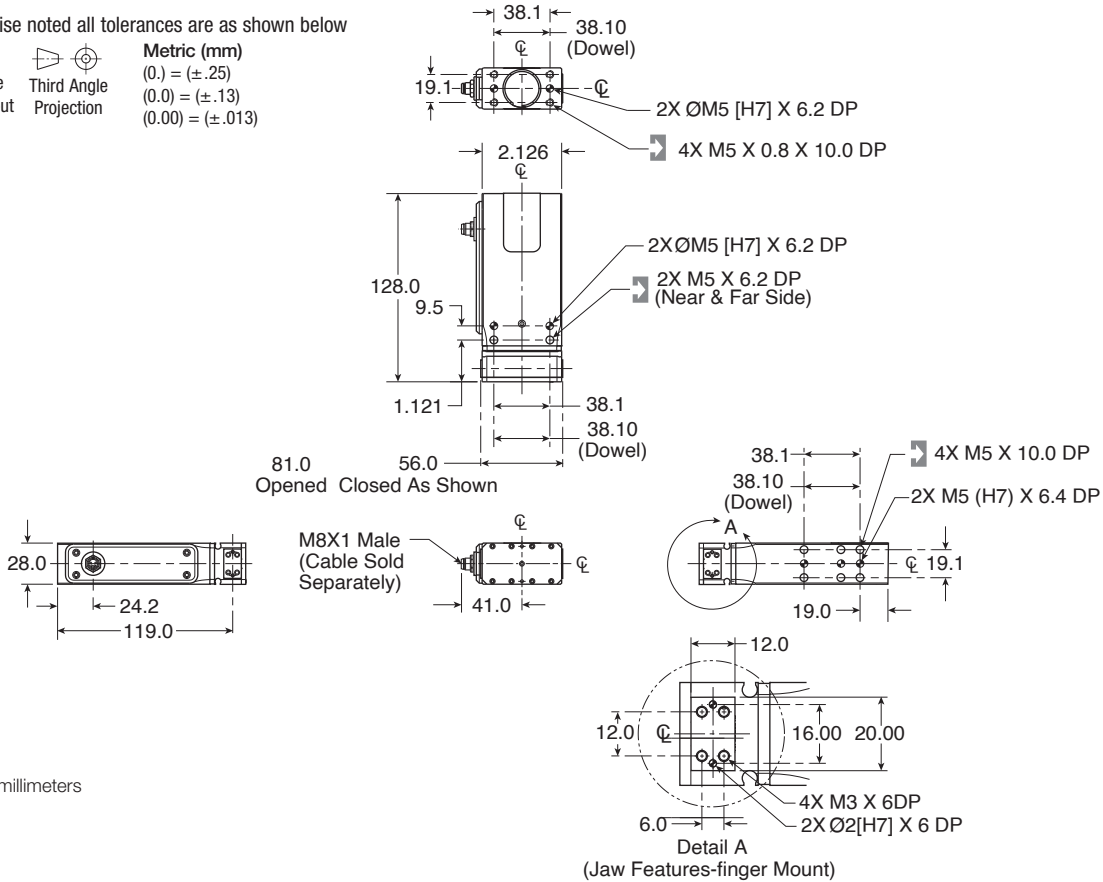

Dimensions in millimeters

**Automation Products**  
**Grippers**  
**Escapements**  
**Fittings**



For inventory, lead times, and kit lookup, visit [www.pdnplu.com](http://www.pdnplu.com)

**Features**

**P5GQ Electric Series, High Force**

- Gripper is available in two stroke lengths, standard and extended stroke
- Ridged design and full body support of the jaws allows for long finger lengths
- Finger locating sleeves for precise finger mounting (standard)
- Slip fit dowel pin holes located in body and jaws for precision mounting
- Jaw components hardened and precision ground steel for minimum jaw play with hard plating for wear resistance and long life
- IP50
- Grip force can be changed on the fly using 0-5V analog input
- No external controller needed, 8-pin cable sold separately
- Magnetic piston standard

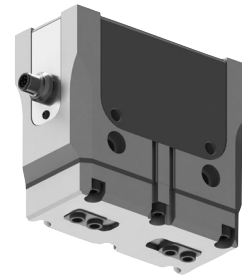

**Operating information**

Voltage:	24VDC
Power Req. @ 100% Duty Cycle:	10 Watts
Current - Peak:	2 Amps Max.
Current - Continuous:	0.4 Amps
Temperature range:	0° to 55° C (32° to 131° F)

**Ordering Information: P5GQ Electric Gripper Series - High Force**

Function	Gripping Mode	Stroke (mm)	Grip Force @ 7 Bar (N)	Accuracy +/- mm	Repeatability +/-mm	Weight (kg)	Part Number
Electric	ID	10.0	667-1334	0.05	0.025	2.52	<b>P5GQ-000RSX010B</b>
Electric	ID	20.0	445-890	0.05	0.025	2.52	<b>P5GQ-000RSX020B</b>
Electric	OD	10.0	667-1334	0.05	0.025	2.52	<b>P5GQ-000QSX010B</b>
Electric	OD	20.0	445-890	0.05	0.025	2.52	<b>P5GQ-000QSX020B</b>

See Sensor section L for part numbers.

**Loading information - P5GQ-000\*010**

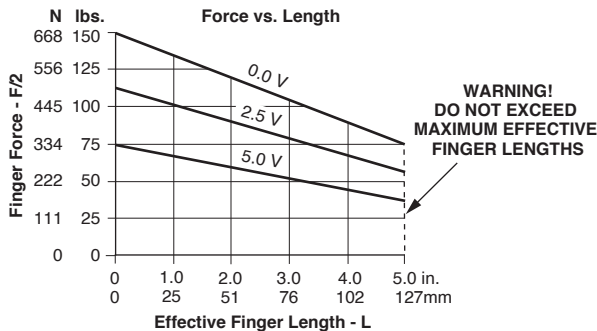

**Loading capacity† - P5GQ-000\*010**

	Static (metric)	Dynamic (Metric)
Maximum Tensile T	1564 N	259 N
Maximum Compressive C	2070 N	259 N
Maximum Moment Mx	76 Nm	10 Nm
Maximum Moment My	106 Nm	14 Nm
Maximum Moment Mz	70 Nm	14 Nm

† Capacities are per set of jaws and are not simultaneous

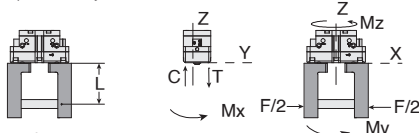

Most popular.

**Loading information - P5GQ-000\*020**

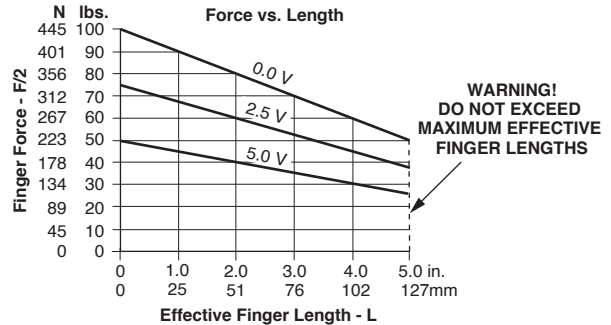

**Loading capacity† - P5GQ-000\*020**

	Static (metric)	Dynamic (Metric)
Maximum Tensile T	1394 N	168 N
Maximum Compressive C	1845 N	168 N
Maximum Moment Mx	68 Nm	6 Nm
Maximum Moment My	84 Nm	8 Nm
Maximum Moment Mz	56 Nm	8 Nm

† Capacities are per set of jaws and are not simultaneous

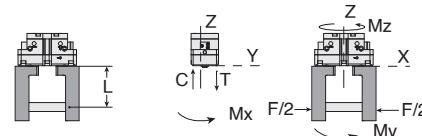

For inventory, lead times, and kit lookup, visit [www.pdnplu.com](http://www.pdnplu.com)

**Dimensions: P5GQ Electric Gripper Series - High Force**

Unless otherwise noted all tolerances are as shown below

 Dimensions are symmetrical about centerline  
 Third Angle Projection  
**Metric (mm)**  
 (0.) = (±.25)  
 (0.0) = (±.13)  
 (0.00) = (±.013)

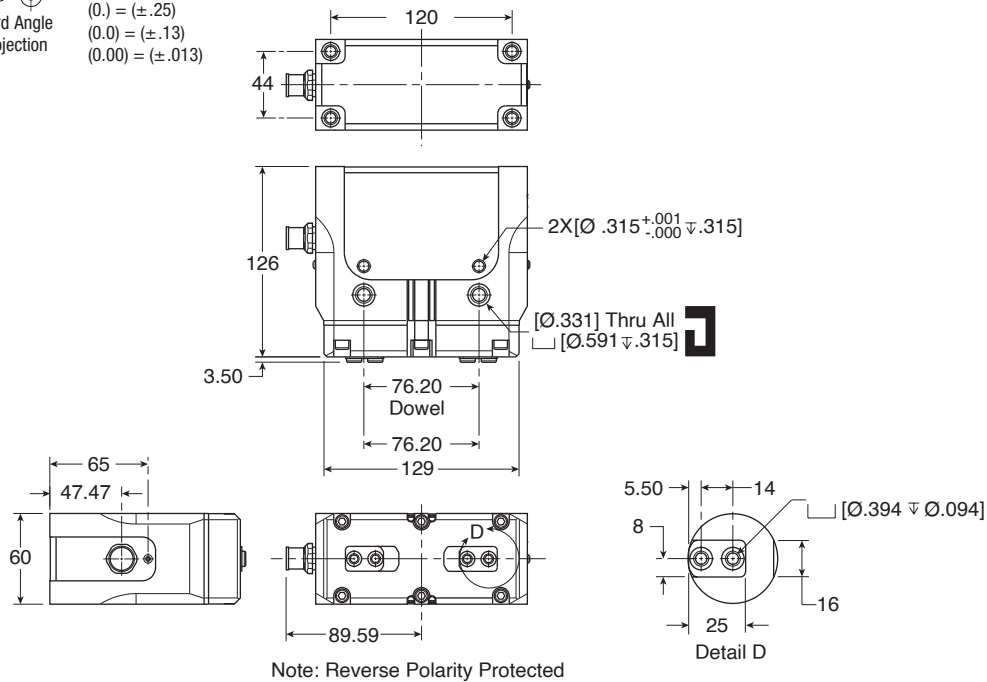

Dimensions in millimeters

**P8S-CABL-052:** 8 Wire power and signal cable, 5m long, straight M12 connector

**P8S-CABL-053:** 8 Wire power and signal cable, 5m long, 90 degree M12 connector

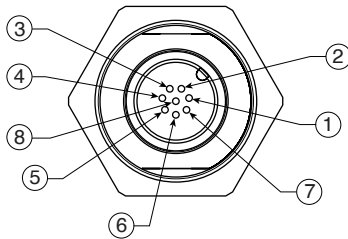

**Electrical interface: Pin out (Looking into the head of the connector on gripper)**

Pin #	Color	Signal	Description	Current
1	White	Force	0-5 VDC (Analog)	5mA
2	Brown	+24V	Motor Power	2A (max), 0.4 A (avg)
3	Green	Open	24 VDC active (Inputs)	10mA
4	Yellow	Open Sense	NPN / PNP (Outputs)	300mA (max)
5	Gray	Close	24 VDC Active (Inputs)	10mA
6	Pink	Close Sense	NPN / PNP (Outputs)	300mA (max)
7	Blue	Ground	Motor Ground	2A (max)
8	Red	I/O Power	24 VDC (PNP outputs only)	300mA (max)

**Features**

**P5GW 3-Jaw Centering Series**

- Multiple side or top air ports (top ports require o-ring)
- Optional spring assist retains the component should the air supply fail, to assist the gripper for internal (-O) or external (-C) gripping, or in single acting or spring assist mode
- Finger locating sleeves for precise finger mounting
- Jaw components hardened and precision ground steel for minimum jaw play with hard plating for wear resistance and long life
- Standard purge / scavenge port used with vacuum for clean room environments or positive pressure for harsh environments
- Gripper can be mounted from the top or bottom
- Gripper body is shielded to repel chips and other particulate from internal drive mechanism
- Magnetic piston standard

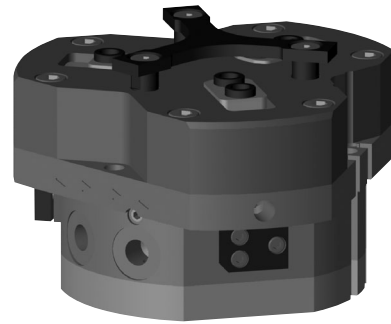

**Operating information**

Operating pressure:	0.3 to 7 bar (4 to 102 PSIG)
Temperature range:	
Nitrile seals (Standard)	-35° to 80° C (-30° to 180° F)
Fluorocarbon seals (Optional)	-30° to 150° C (-20° to 300° F)
Filtration requirements:	
Air filtration	40 micron or better
Air lubrication	Not necessary*
Air humidity	Low moisture content (dry)
*Addition of lubrication will greatly increase service life	

**Ordering Information: P5GW 3-Jaw Centering Series**

Function	Bore Size (mm)	Stroke (mm)	Grip Force @ 7 Bar (N)	Accuracy +/- mm	Repeatability +/-mm	Weight (kg)	Part Number Fluorocarbon	Part Number Nitrile
Double Acting Magnetic	32	4.0	682	0.04	0.02	0.25	<b>P5GW-032MFG004B</b>	<b>P5GW-032MSG004B</b>
Double Acting Magnetic	43	6.0	1238	0.04	0.02	0.53	<b>P5GW-043MFG006B</b>	<b>P5GW-043MSG006B</b>
Double Acting Magnetic	55	8.0	2078	0.04	0.02	1.08	<b>P5GW-055MFG008B</b>	<b>P5GW-055MSG008B</b>
Double Acting Magnetic	72	10.0	3644	0.06	0.03	1.95	<b>P5GW-072MFG010B</b>	<b>P5GW-072MSG010B</b>
Double Acting Magnetic	95	13.0	6353	0.06	0.03	3.9	<b>P5GW-095MFG013B</b>	<b>P5GW-095MSG013B</b>
Double Acting Magnetic	120	16.0	10202	0.08	0.04	7.89	<b>P5GW-120MFG016B</b>	<b>P5GW-120MSG016B</b>
Double Acting Magnetic	156	25.0	17165	0.10	0.05	15.7	<b>P5GW-156MFG025B</b>	<b>P5GW-156MSG025B</b>
Double Acting Magnetic	225	35.0	35288	0.10	0.05	43.9	<b>P5GW-225MFG035B</b>	<b>P5GW-225MSG035B</b>

Function	Bore Size (mm)	Stroke (mm)	Grip Force @ 7 Bar (N)	Accuracy +/- mm	Repeatability +/-mm	Weight (kg)	Part Number Spring Close
Spring Closing Magnetic	32	4.0	889	0.04	0.02	0.25	<b>P5GW-032DSG004B</b>
Spring Closing Magnetic	43	6.0	1490	0.04	0.02	0.53	<b>P5GW-043DSG006B</b>
Spring Closing Magnetic	55	8.0	2627	0.04	0.02	1.08	<b>P5GW-055DSG008B</b>
Spring Closing Magnetic	72	10.0	4562	0.06	0.03	1.95	<b>P5GW-072DSG010B</b>
Spring Closing Magnetic	95	13.0	7877	0.06	0.03	3.9	<b>P5GW-095DSG013B</b>
Spring Closing Magnetic	120	16.0	13786	0.08	0.04	7.89	<b>P5GW-120DSG016B</b>
Spring Closing Magnetic	156	25.0	22093	0.10	0.05	15.7	<b>P5GW-156DSG025B</b>
Spring Closing Magnetic	225	35.0	44354	0.10	0.05	43.9	<b>P5GW-225DSG035B</b>

See Sensor section L for part numbers.

Most popular.



For inventory, lead times, and kit lookup, visit [www.pdnplu.com](http://www.pdnplu.com)

**Loading information - P5GW-032**

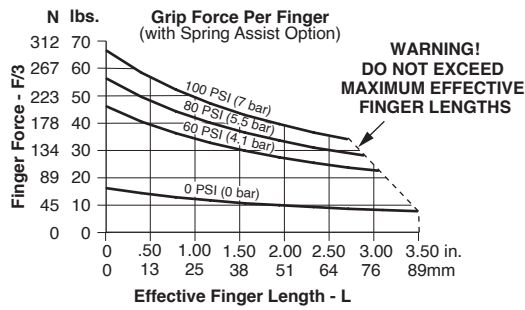

**Loading information - P5GW-095**

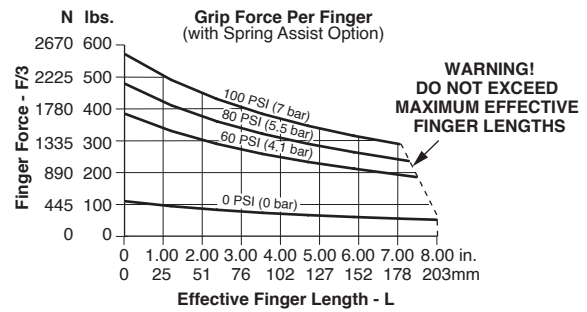

**Loading information - P5GW-043**

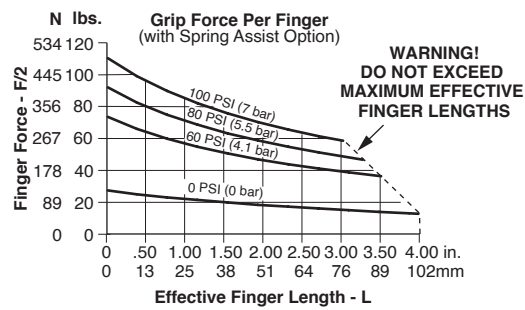

**Loading information - P5GW-120**

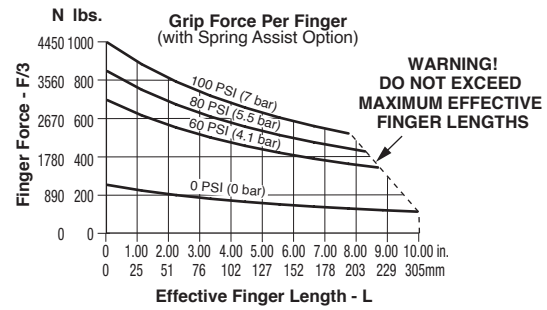

**Loading information - P5GW-055**

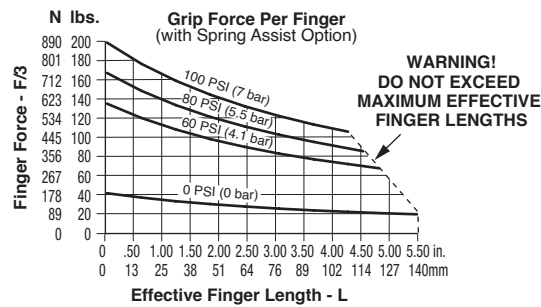

**Loading information - P5GW-156**

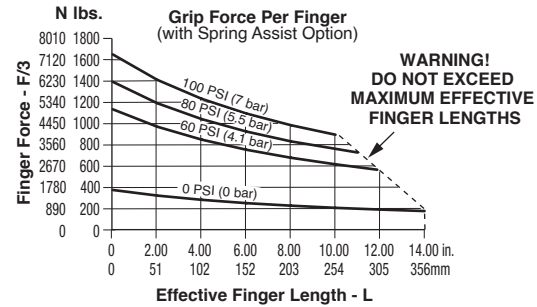

**Loading information - P5GW-072**

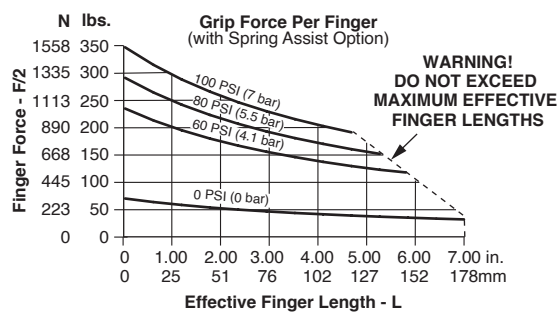

**Loading information - P5GW-225**

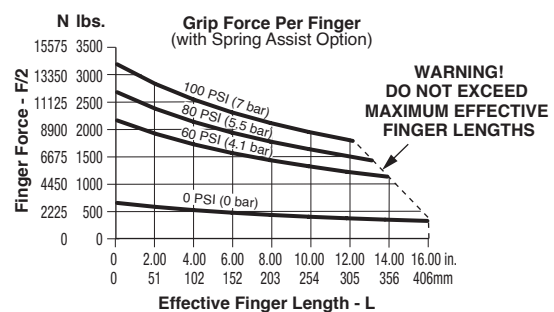

**P**  
 Automation  
 Products  
 Grippers  
 Escapements  
 Fittings



For inventory, lead times, and kit lookup, visit [www.pdnplu.com](http://www.pdnplu.com)

**Loading capacity† - P5GW 3-Jaw Centering Series**

	P5GW-32		P5GW-43		P5GW-55		P5GW-72	
	Static (metric)	Dynamic (metric)	Static (metric)	Dynamic (metric)	Static (metric)	Dynamic (metric)	Static (metric)	Dynamic (metric)
<b>Maximum Tensile T</b>	810 N	89 N	1200 N	129 N	1680 N	302 N	2110 N	425 N
<b>Maximum Compressive C</b>	1060 N	89 N	1560 N	129 N	2180 N	302 N	2790 N	425 N
<b>Maximum Moment Mx</b>	22 Nm	2 Nm	45 Nm	4 Nm	72 Nm	11 Nm	92 Nm	16 Nm
<b>Maximum Moment My</b>	28 Nm	3 Nm	64 Nm	6 Nm	102 Nm	16 Nm	182 Nm	22 Nm
<b>Maximum Moment Mz</b>	18 Nm	3 Nm	41 Nm	6 Nm	66 Nm	16 Nm	84 Nm	22 Nm

	P5GW-95		P5GW-120		P5GW-156		P5GW-225	
	Static (metric)	Dynamic (metric)	Static (metric)	Dynamic (metric)	Static (metric)	Dynamic (metric)	Static (metric)	Dynamic (metric)
<b>Maximum Tensile T</b>	2990 N	674 N	4320 N	1315 N	5400 N	1763 N	8230 N	2733 N
<b>Maximum Compressive C</b>	3980 N	674 N	5810 N	1315 N	7120 N	1763 N	10700 N	2733 N
<b>Maximum Moment Mx</b>	127 Nm	25 Nm	172 Nm	45 Nm	215 Nm	60 Nm	455 Nm	131 Nm
<b>Maximum Moment My</b>	179 Nm	35 Nm	250 Nm	65 Nm	305 Nm	86 Nm	578 Nm	167 Nm
<b>Maximum Moment Mz</b>	117 Nm	35 Nm	164 Nm	65 Nm	208 Nm	86 Nm	362 Nm	167 Nm

† Capacities are per set of jaws and are not simultaneous



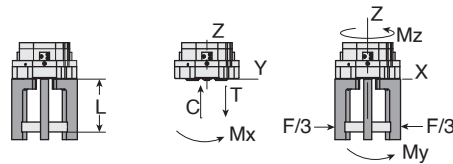

**Dimensions: P5GW 3-Jaw Centering Series**

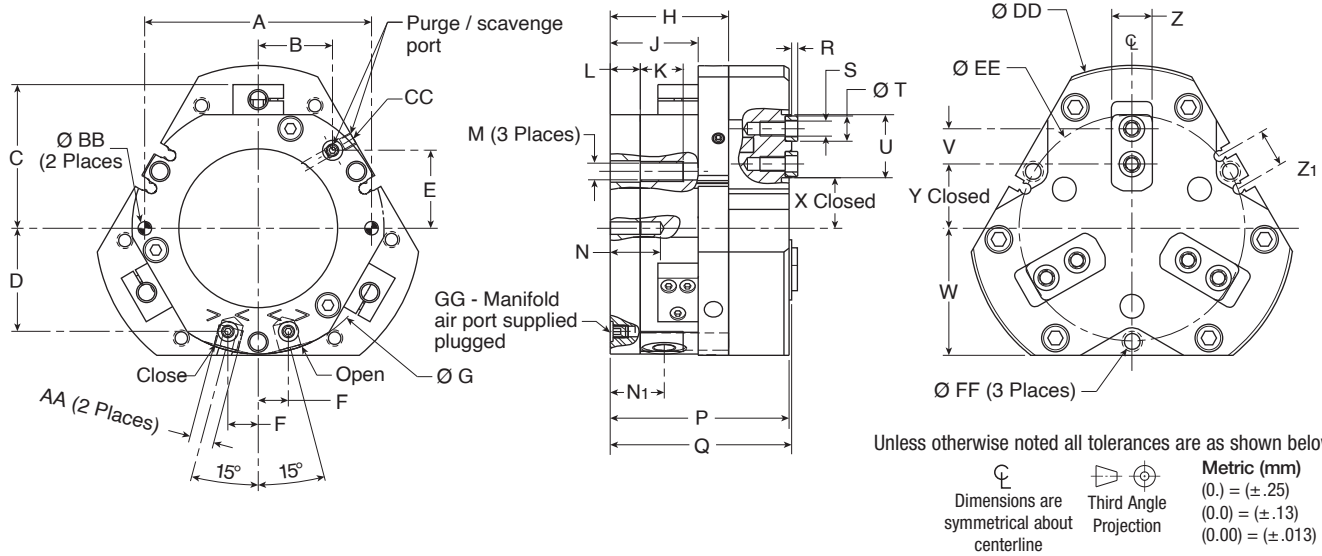

Part Number	A	B	C	D	E	F	G	H	J	K	L	M	N	N <sub>1</sub>	P	Q	R	S
<b>P5GW-032</b>	45.00	13.4	—	19.5	15.8	7.0	51	24.5	18.5	9	6.0	M4	12	11.5	36.5	37.0	1.5	M3 x 5 Dp
<b>P5GW-043</b>	56.00	17.2	37.7	25.0	20.3	9.0	64	32.5	25.5	13	9.0	M6	15	15.5	48.5	49.0	1.5	M4 x 6 Dp
<b>P5GW-055</b>	70.00	23.2	46.7	32.0	23.8	9.0	80	43.5	33.5	17	12.0	M8	20	20.0	63.5	64.0	2.0	M5 x 9 Dp
<b>P5GW-072</b>	90.00	29.5	57.0	41.0	30.9	12.0	100	47.0	35.0	17	12.0	M8	20	21.5	71.0	72.0	2.5	M6 x 10 Dp
<b>P5GW-095</b>	112.00	38.4	71.0	53.0	39.5	15.0	125	57.0	42.0	22	14.0	M10	24	25.0	87.0	88.0	2.5	M6 x 10 Dp
<b>P5GW-120</b>	146.00	49.0	87.0	67.5	50.2	19.0	160	72.0	53.0	22	20.0	M10	30	33.0	109.0	110.0	3.0	M8 x 17 Dp
<b>P5GW-156</b>	184.00	64.3	106.0	87.5	63.7	23.0	200	92.0	70.0	26	24.0	M12	36	43.0	142.0	143.0	4.0	M12 x 17 Dp
<b>P5GW-225</b>	270.00	90.5	150.0	123.0	89.2	32.0	300	125.0	99.0	40	30.0	M20	46	60.0	195.0	196.0	5.0	M16 x 21 Dp

Part Number	T	U	V	W	X	Y	Z	Z <sub>1</sub>	AA	BB	CC	DD	EE	FF	GG
<b>P5GW-032</b>	5h7	14.0	8.00	26.0	9.0	12.0	8.0	12.0	M5 x 5 Dp	3h7	M5 x 5 Dp	63	45	3.3	M3 x 4
<b>P5GW-043</b>	6h7	16.0	9.00	32.5	13.0	16.5	10.0	15.0	M5 x 5 Dp	4h7	M5 x 5 Dp	83	56	5.2	M3 x 4
<b>P5GW-055</b>	8h7	20.0	11.00	40.5	16.0	20.5	12.5	15.0	M5 x 5 Dp	5h7	M5 x 5 Dp	104	70	6.8	M4 x 6
<b>P5GW-072</b>	10h7	25.0	14.00	50.5	20.0	25.5	16.0	15.0	M5 x 5 Dp	5h7	M5 x 5 Dp	129	90	6.8	M5 x 6
<b>P5GW-095</b>	10h7	32.0	20.00	63.0	24.5	30.5	20.0	18.0	G1/8 x 8 Dp	6h7	M5 x 5 Dp	162	112	8.5	M5 x 6
<b>P5GW-120</b>	12h7	40.0	25.00	83.5	32.0	39.5	25.0	18.0	G1/8 x 8 Dp	6h7	M5 x 5 Dp	205	146	8.5	M5 x 6
<b>P5GW-156</b>	16h7	43.0	25.00	105.0	42.0	51.0	31.0	21.0	G1/8 x 8 Dp	8h7	G1/8 x 8 Dp	258	184	10.3	M5 x 6
<b>P5GW-225</b>	22h7	58.0	34.00	155.0	57.0	69.0	46.0	29.0	G1/8 x 12 Dp	10h7	G1/8 x 8 Dp	355	260	17.5	M8 x 10

Dimensions in millimeters

**Automation Products**  
**Grippers**  
**Escapements**  
**Fittings**



For inventory, lead times, and kit lookup, visit [www.pdnplu.com](http://www.pdnplu.com)



## P5MD Feed Escapements

- Most effective mechanism for separating parts fed from a track or conveyor
- 7075-T6 aircraft quality aluminum body hard-coat anodized 60 RC with PTFE impregnation
- Adjustable retract stops
- Built-in sensor mounting slots
- Built-in sensor magnet for use with Hall Effect sensors
- Sealed design repels contaminants
- Slip fit dowel holes in body for precision applications
- Dynamic components are precision ground and hardened for wear resistance and long life
- Locking key ensures part separation and eliminates jams

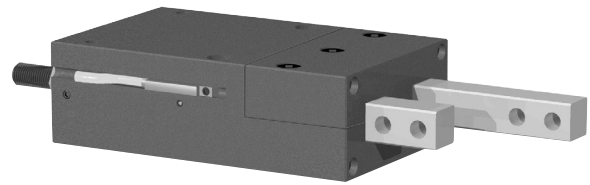

### Operating information

Operating pressure:	3 to 7 bar (44 to 102 PSIG)
Temperature range:	
Nitrile seals (Standard)	-35° to 80° C (-30° to 180° F)
Filtration requirements:	
Air filtration	40 micron or better
Air lubrication	Not necessary*
Air humidity	Low moisture content (dry)
*Addition of lubrication will greatly increase service life	

### Ordering Information: P5MD Feed Escapements

Stroke (mm)	Thrust Force @ 7 Bar (N)	Parts Escaped Per Minute	Weight (kg)	Side Finger Mount	Top Finger Mount
15.9	111	150	0.15	<b>P5MD-014SSG016B</b>	<b>P5MD-014TSG016B</b>
25.4	222	100	0.39	<b>P5MD-020SSG025B</b>	<b>P5MD-020TSG025B</b>
31.8	400	85	0.83	<b>P5MD-027SSG032B</b>	<b>P5MD-027TSG032B</b>

See Sensor section L for part numbers.

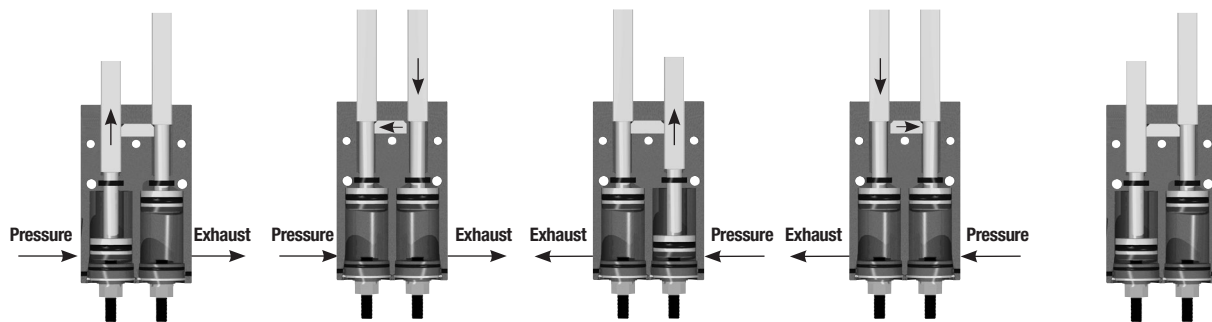

- Dual double acting pistons slide in opposite directions within the body through the use of internal porting.
- When pressure is applied, one piston extends and passes a part in its cylinder wall which is linked to the retract side of the other piston's cylinder.
- The second piston then begins to retract and pushes the locking key aside into the cavity on the side of the first finger.
- Locking Key ensures only 1 finger can be retracted at a time.
- Finger must be allowed to fully extend for proper operation.

☐ Most popular.



For inventory, lead times, and kit lookup, visit [www.pdnplu.com](http://www.pdnplu.com)

**Loading capacity - P5MD Feed Escapements**

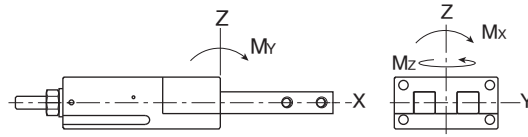

	<b>P5MD-014</b>		<b>P5MD-020</b>		<b>P5MD-027</b>	
	Static (metric)	Dynamic (metric)	Static (metric)	Dynamic (metric)	Static (metric)	Dynamic (metric)
Maximum Moment Mx	6 Nm	0.57 Nm	17 Nm	1.70 Nm	28 Nm	2.83 Nm
Maximum Moment My	6 Nm	0.57 Nm	17 Nm	1.70 Nm	28 Nm	2.83 Nm
Maximum Moment Mz	6 Nm	0.57 Nm	17 Nm	1.70 Nm	28 Nm	2.83 Nm

**Dimensions: P5MD Feed Escapements**

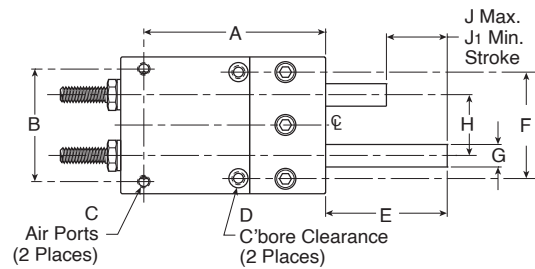

Unless otherwise noted all tolerances are as shown below

Dimensions are symmetrical about centerline  
 Third Angle Projection  
**Metric (mm)**  
 (0.) = (±.25)  
 (0.0) = (±.13)  
 (0.00) = (±.013)

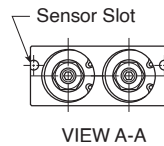
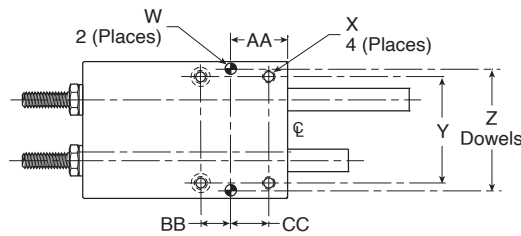
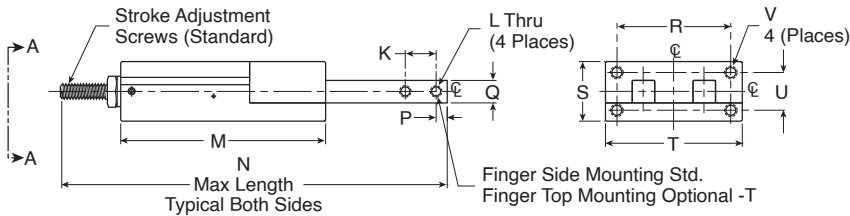

Part Number	A	B	C	D	E	F	G	H	J	J1	K	L	M	N	P	Q	R	S	T
<b>P5MD-014</b>	51	30	M5	∅ 5.64 x 3.2 Dp	41.3	38.1	7.9	15.9	15.9	4.8	12.7	M4	57.9	117	4.8	7.9	38.1	19.1	31.8
<b>P5MD-020</b>	76	47	M5	∅ 7.95 x 1.6 Dp	50.8	44.5	9.5	25.4	25.4	6.4	12.7	M5	85.5	162	4.8	9.5	47.6	24.9	57.2
<b>P5MD-027</b>	100	57.1	M5	∅ 8.9 x 5 Dp	57.2	57.1	12.7	31.8	31.8	12.7	12.7	M6	112.3	197	6.4	12.7	60.3	34.5	69.9

Part Number	U	V	W	X	Y	Z	AA	BB	CC
<b>P5MD-014</b>	12.7	M4 x 5.5 Dp	∅ 3 H7 x 3.8 Dp	M4 x 5 Dp	31.8	31.75	15.1	9.5	9.5
<b>P5MD-020</b>	15.9	M5 x 10 Dp	∅ 5 H7 x 5 Dp	M5 x 7 Dp	44.5	50.80	23.8	12.7	15.9
<b>P5MD-027</b>	25.4	M6 x 10 Dp	∅ 5 H7 x 6 Dp	M6 x 11 Dp	57.1	57.15	31.0	19.0	19.0

Dimensions in millimeters

**E**  
 Automation Products  
 Grippers  
 Escapements  
 Fittings



For inventory, lead times, and kit lookup, visit [www.pdnplu.com](http://www.pdnplu.com)

**Rodless Design  
Pneumatic Cylinders**

**OSP-P Series - Band Type Rodless**

System Concept & Components	G2-G8
<b>Standard Series</b>	
Features	G9-G10
Ordering Information	G11
Options / Technical Data	G12-G15
Dimensional Data	G16-G19
3/2 Way Valves VOE	G20-G21
Active Brake	G22-G25
Accessories	G26-G33
Clean Room	G34-G37
Bi-Parting	G38-G40

**Linear Guides**

Features	G41-G42
SLIDELINE	G43-G47
POWERSLIDE	G48-G51
PROLINE	G52-G56
STARLINE	G57-G61
KF	G62-G68
HD	G69-G76
Linear Guide Accessories	G77-G86
Sensoflex	G87-G89

**P1X Series - Band Type Rodless**

Features	G90
Ordering Information	G91
Specifications / Technical Data	G92-G96
Dimensional Data	G97-G99
Accessories	G100-G107

**GDL Series - Rails & Cassettes**

Features	G108-G109
Ordering Information / Stroke Lengths	G110
Specifications	G111
Dimensional Data	G112
Accessories	G113-G114
Technical Data	G115-G120

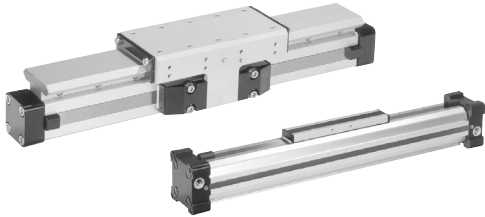

# OSP

Parker's rodless pneumatic cylinders are the first rodless cylinders that have been approved for use in potentially explosive atmospheres in Equipment Group II, Category 2 GD

The Cylinders are to the ATEX Certification 94/9/EG (ATEX 95) for Pneumatic Components.

## ATTENTION!

Contact Parker for sizing software and/or technical assistance 877-321-4736

All dimensions are in European-Standard.  
 Please convert all in US-Standard.

## Conversion Table

Multiply	By	To Obtain
millimeters	.03937	inches
newtons	.2248	lbs.(F)
newton-meters	8.8512	in-lbs
kilograms	2.205	lbs.
inches	25.4	millimeters
lbs.(F)	4.448	newtons
in-lbs	.113	newtons-meters
lbs.	.45359	kilograms

**G**

Rodless Pneumatic Cylinders

OSP-P Series

P1X Series

GDL Series

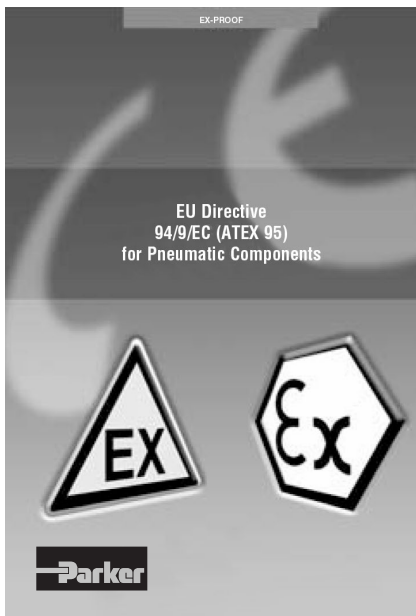

for use in Ex-Areas



for Clean Room Applications certified to DIN EN ISO 14644-1



Stainless steel hardware for special applications

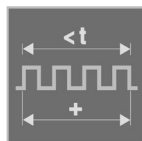

with special pneumatic cushioning system for cycle time optimization, for Ø 16 to 50 mm – on request

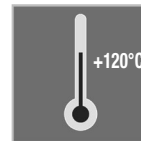

High Temperature Version for temperatures up to +100°C



Low Temperature Version for temperatures up to -10°C (25, 32, 40mm Ø)

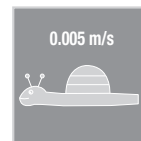

Slow Speed Version v = 0.005 – 0.2 m/s

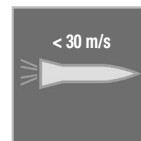

High Speed Version v<sub>max.</sub> = 30 m/s (16, 25, 32mm Ø)

2D & 3D CAD Drawings can be downloaded from website [www.parker.com/pneu/rodless](http://www.parker.com/pneu/rodless)

**One Concept – Pneumatic**

Based on the Parker's rodless cylinder, proven in world wide markets, Parker now offers the complete pneumatic solution for linear systems. Designed for absolute reliability, high performance, ease of use and optimized engineering the OSP SERIES satisfies even the most demanding applications.

**OSP SERIES**

is a totally modular concept which offers pneumatic actuation, with guidance options to suit the exact needs of individual installations.

The actuators at the core of the system all have a common aluminum extruded profile, with double dovetail mounting rails on three sides, these are the principle building blocks of the system to which all modular options are directly attached.

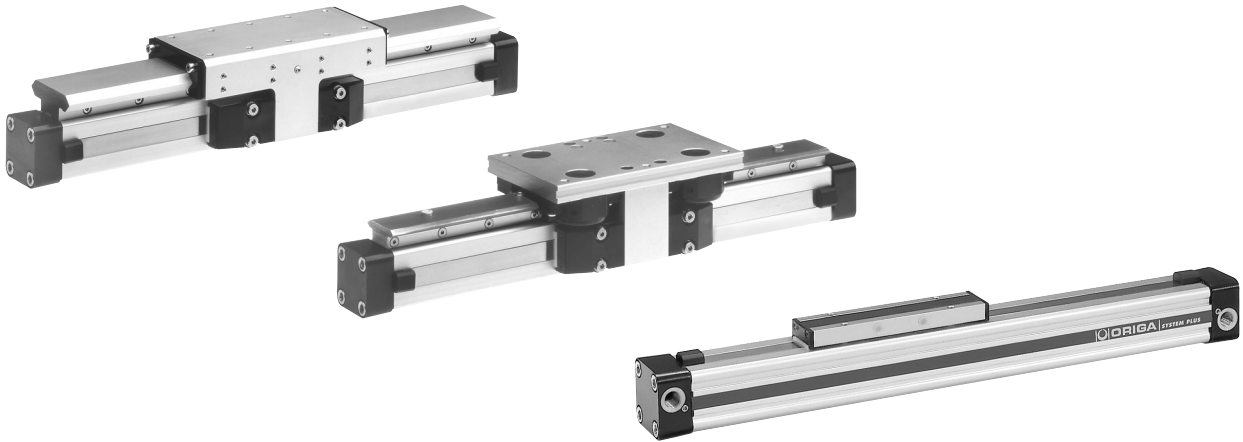
**SYSTEM MODULARITY**

- Pneumatic Drive
  - For all round versatility and convenience, combining ease of control and broad performance capability. Ideally suited for point-to point operations, reciprocating movements and simple traverse / transfer applications.
- Different guidance options provide the necessary level of precision, performance and duty for various applications.
- Compact solutions, which are simple to install and can be easily retrofitted.
- Valves and control options can be directly mounted to the actuator system.
- Diverse mounting options to provide total installation flexibility.

**G**Rodless Pneumatic  
CylindersOSP-P  
SeriesP1X  
SeriesGDL  
Series

# The System Concept

# Rodless Pneumatic Cylinders OSP-P Series

## Basic Linear Drive



### STANDARD VERSION

- OSP-P

## Air Connection on the End-face or both at One End

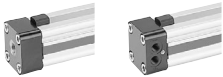

- OSP-P

## Clean Room Cylinder certified to DIN EN ISO 146644-1

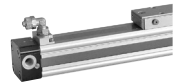

- Series OSP-P

## Bi-parting Version

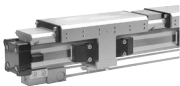

- OSP-P

## Integrated 3/2 Way Valves



- OSP-P

## Clevis Mounting

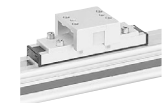

- OSP-P

## End Cap Mounting



- OSP-P

## Mid-Section Support



- OSP-P

## Inversion Mounting



- OSP-P

## Linear Guides

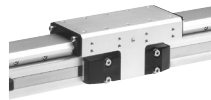

### SLIDELINE

- OSP-P



### POWERSLIDE

- OSP-P



### PROLINE

- OSP-P



### STARLINE

- OSP-P



### KF - Recirculating Ball Bearing

- OSP-P

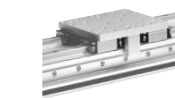

### HD - Heavy Duty

- OSP-P

## Intermediate Stop Module

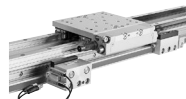

### ZSM

- OSP-P

## Brakes



- Active Brakes
- Passive Brakes

## Magnetic Switches



- OSP-P

## SENSOFLEX – Measuring System



- SFI-plus

## Variable Stop VS



- OSP-P with Linear Guide  
STL, KF, HD

**G**  
 Rodless Pneumatic  
 Cylinders  
 OSP-P  
 Series  
 P1X  
 Series  
 GDL  
 Series



For inventory, lead times, and kit lookup, visit [www.pdnplu.com](http://www.pdnplu.com)

<b>Linear Drives</b>	OSP-P10	OSP-P16	OSP-P25	OSP-P32	OSP-P40	OSP-P50	OSP-P63	OSP-P80
<b>Specifications</b>								
Theoretical Force at 6 bar (N)	47	120	295	483	754	1178	1870	3010
Effective Force at 6 bar (N)	32	78	250	420	640	1000	1550	2600
Velocity v (m/s)	> 0.005	> 0.005	> 0.005	> 0.005	> 0.005	> 0.005	> 0.005	> 0.005
Magnetic Piston (three sides)		☐	☐	☐	☐	☐	☐	☐
Lubrication - Prelubricated	☐	☐	☐	☐	☐	☐	☐	☐
Multiple Air Ports ( 4 x 90°)		☐	☐	☐	☐	☐	☐	☐
Both Air Connections at End-face		○	○	○	○	○	○	○
Air Connection on the End-face		○	○	○	○	○	○	○
Cushioning	☐	☐	☐	☐	☐	☐	☐	☐
Cushioning Length (mm)	2,50	11	17	20	27	30	32	39
Stroke Length (mm) ▲	1 - 5500	1 - 5500	1 - 5500	1 - 5500	1 - 5500	1 - 5500	1 - 5500	1 - 5500
Pressure Range pmax (bar)	8.0	8.0	8.0	8.0	8.0	8.0	8.0	8.0
Temperature Range (°C) *	-10 – + 80	-10 – + 80	-10 – + 80	-10 – + 80	-10 – + 80	-10 – + 80	-10 – + 80	-10 – + 80
Fluorocarbon / Chemical Resistance	○	○	○	○	○	○	○	○
Stainless Steel Parts	○	○	○	○	○	○	○	○
Clevis Mounting	○	○	○	○	○	○	○	○
Slow Speed Lubrication	○	○	○	○	○	○	○	○
Duplex Connection / Multiplex Connection		on request	○	○	○	○	on request	on request
Tandem Piston	○	○	○	○	○	○	○	○
<b>Basic Cylinder</b>								
F (N)	20	120	300	450	750	1200	1650	2400
Mx (Nm)	0.2	0.45	1.5	3	6	10	12	24
My (Nm)	1	4	15	30	60	115	200	360
Mz (Nm)	0.3	0.5	3	5	8	15	24	48
<b>SLIDELINE</b>								
F (N)		325	675	925	1500	2000	2500	2500
Mx (Nm)		6	14	29	50	77	120	120
My (Nm)		11	34	60	110	180	260	260
Mz (Nm)		11	34	60	110	180	260	260
<b>PROLINE</b>								
F (N)		542	857	1171	2074	3111		
Mx (Nm)		8	16	29	57	111		
My (Nm)		12	39	73	158	249		
Mz (Nm)		12	39	73	158	249		
<b>POWERSLIDE</b>								
F (N)		1400	1400 - 3000	1400 - 3000	3000	3000 - 4000		
Mx (Nm)		14	14 - 65	20 - 65	65 - 90	90 - 140		
My (Nm)		45	63 - 175	70 - 175	175 - 250	250 - 350		
Mz (Nm)		45	63 - 175	70 - 175	175 - 250	250 - 350		
<b>STARLINE</b>								
F (N)		1000	3100	3100	4000-7500	4000-7500		
Mx (Nm)		15	50	62	150	210		
My (Nm)		30	110	160	400	580		
Mz (Nm)		30	110	160	400	580		
- Variable Stop		○	○	○	○	○		

- ☐ = Standard Version
- ▲ = Longer Strokes on Request
- \* = Other Temperature Ranges on Request
- = Option
- X = Not Applicable

  
**Rodless Pneumatic Cylinders**  
 OSP-P Series  
 P1X Series  
 GDL Series



For inventory, lead times, and kit lookup, visit [www.pdnplu.com](http://www.pdnplu.com)

Modular Components Overview

Linear Drives	OSP-P10	OSP-P16	OSP-P25	OSP-P32	OSP-P40	OSP-P50	OSP-P63	OSP-P80
<b>KF Guide</b>								
F (N)		1000	3100	3100	4000-7500	4000-7500		
Mx (Nm)		12	35	44	119	170		
My (Nm)		25	90	133	346	480		
Mz (Nm)		25	90	133	346	480		
- Variable Stop		○	○	○	○	○		
<b>HD Heavy Duty Guide</b>								
F (N)			6000	6000	15000	18000		
Mx (Nm)			260	285	800	1100		
My (Nm)			320	475	1100	1400		
Mz (Nm)			320	475	1100	1400		
- Variable Stop			○	○	○	○		
- Intermediate Stop Module			○					
<b>Active Brake</b>								
Braking Force at 6 bar (brake surface dry) (N)								
<b>SLIDELINE SL / PROLINE PL with Brakes</b>								
<b>Active Brake</b>								
SL Braking Force at 6 bar (brake surface dry) (N)			325	545	825	1200		
PL Braking Force at 6 bar (brake surface dry) (N)			on request	on request	on request	on request		
<b>Passive Brake Multibrake</b>								
SL Braking Force at 6 bar (brake surface dry) (N)			470	790	1200	1870	2900	2900
PL Braking Force at 6 bar (brake surface dry) (N)			315	490	715	1100		
<b>Magnetic Switches</b>								
Standard Version	○	○	○	○	○	○	○	○
T-Nut Version	○	○	○	○	○	○	○	○
<b>Displacement Measuring Systems</b>								
SFI-plus Incremental			○	○	○	○	○	○
<b>Integrated Valves 3/2 WV NO VOE</b>								
			○	○	○	○	on request	on request
<b>Mountings</b>								
End Cap Mounting / Mid-Section Support	○	○	○	○	○	○	○	○
Inversion Mounting		○	○	○	○	○	○	○
Shock Absorber for Intermediate Positioning			on request	on request	on request	on request		
Adaptor Profile / T-Nut Profile		○	○	○	○	○		
<b>Special Cylinders</b>								
Special Pneumactical Cushioning System		on request	on request	on request	on request	on request		
Clean Room Cylinders to DIN EN ISO 14644-1		○	○	○				
Bi-parting Version					○			
High-Speed up to 30 m/s		on request	on request	on request				
□ = Standard Version ▲ = Longer Strokes on Request * = Other Temperature Ranges on Request ○ = Option X = Not Applicable								

G Rodless Pneumatic Cylinders  
 OSP-P Series  
 P1X Series  
 GDL Series



For inventory, lead times, and kit lookup, visit [www.pdnplu.com](http://www.pdnplu.com)



**Examples**

**Rodless Pneumatic Cylinders  
OSP-P Series**

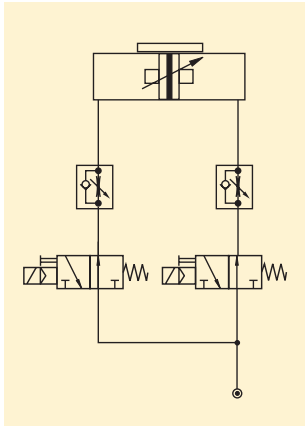

Circuit diagram for end of stroke application. Intermediate positioning is also possible.

The cylinder is controlled by two 3/2-way valves (normally open). The speed can be adjusted independently for both directions.

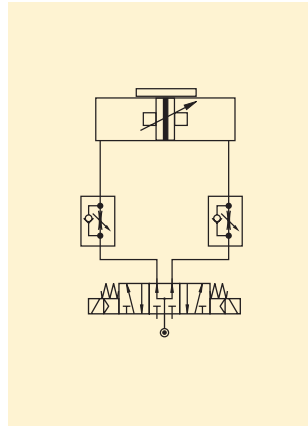

Circuit diagram for end of stroke application. Intermediate positioning is also possible.

The cylinder is controlled by a 5/3-way valve (middle position pressurized). The speed can be adjusted independently for both directions.

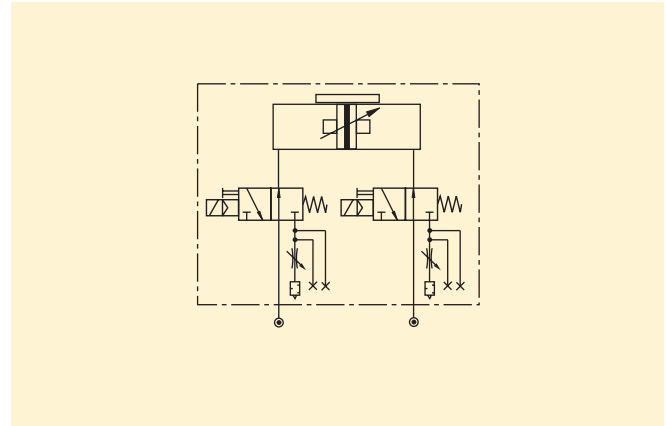

The optional integrated VOE Valves offer optimal control, and allow accurate positioning of intermediate positions and the lowest possible speeds.

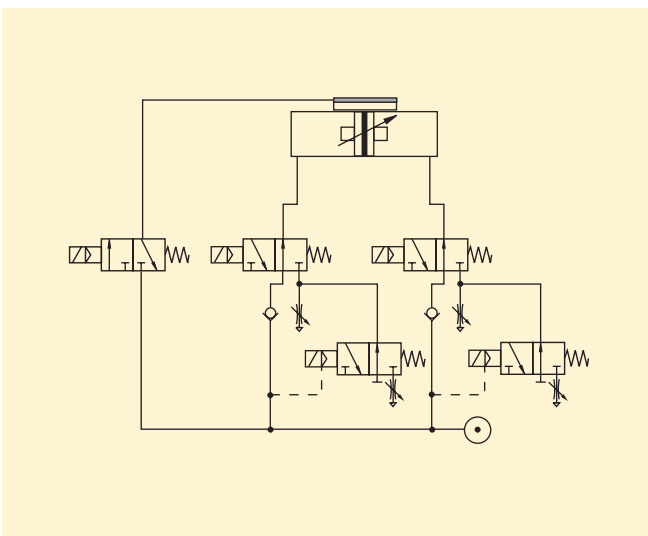

Fast/Slow speed cycle control with pneumatic brake for accurate positioning at high velocities. Additional 3/2-way valves with adjustable throttle valves at the exhaust of the standard directional control valves for two displacement speeds in each direction of the piston's travel.

The valve controlling the brake is activated after the slow speed cycle is activated.

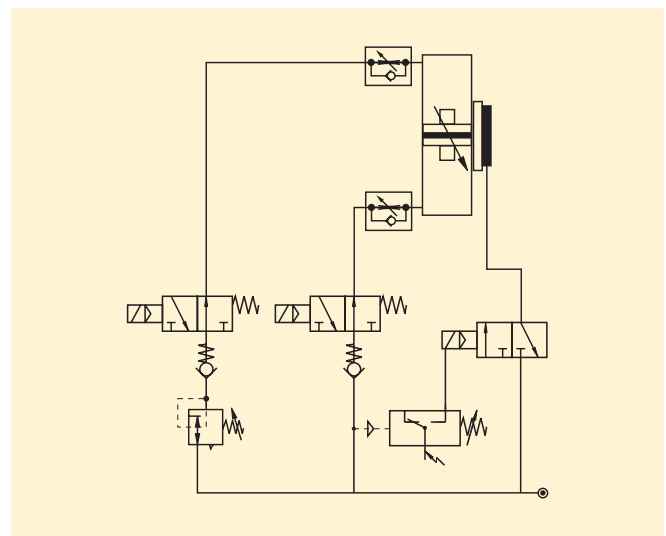

The combination of an OSP-cylinder with the passive MULTIBRAKE as shown here, allows accurate positioning and safety in case of loss of pneumatic air pressure.



For inventory, lead times, and kit lookup, visit [www.pdnplu.com](http://www.pdnplu.com)

**OSP SERIES – rodless linear drives offer maximum flexibility for any application.**

The high load capacity of the piston can cope with high bending moments without additional guides.

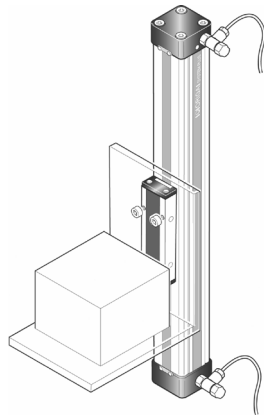

Integrated guides offer optimal guidance for applications requiring high performance, easy assembly and maintenance free operation.



SLIDELINE

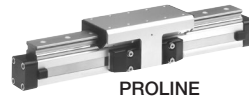

PROLINE



POWERSLIDE



STARLINE

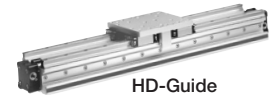

HD-Guide

The mechanical design of the OSP-P allows synchronized movement of two cylinders.

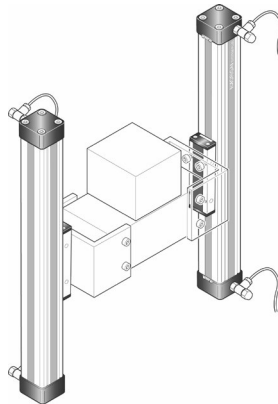

Optimal system performance by combining multi-axis cylinder combinations.

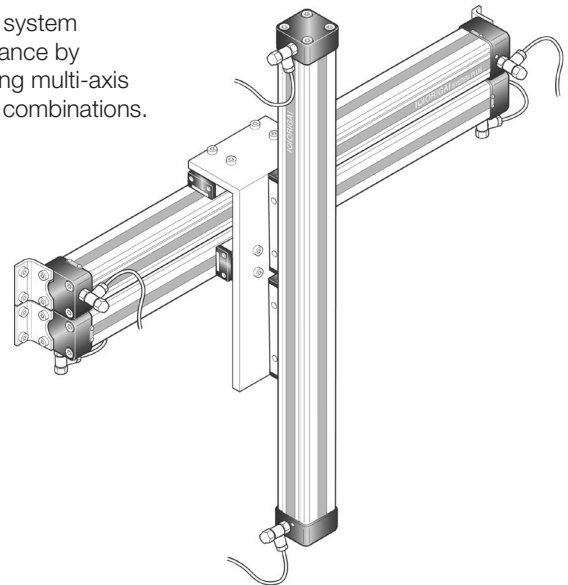

When using external guides, the clevis mounting is used to compensate for deviations in parallelism.

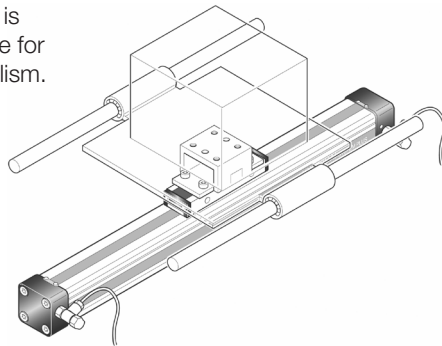

<b>G</b>	Rodless Pneumatic Cylinders
	OSP-P Series
	P1X Series
	GDL Series

**For further information and assembly instructions, please contact your local Parker dealer.**



For inventory, lead times, and kit lookup, visit [www.pdnplu.com](http://www.pdnplu.com)

**OSP-P Series**

A new generation of linear drives which can be simply and neatly integrated into any machine layout.

**A new modular linear drive system**

With this second generation linear drive the OSP-P series offers design engineers complete flexibility.

The cylinder has been further developed into a combined linear actuator, guidance and control package. It forms the basis for the OSP-P linear drive system.

All additional functions are designed into modular system components which replace the previous series of cylinders.

**Mounting rails on 3 sides**

Mounting rails on 3 sides of the cylinder enable modular components such as linear guides, brakes, valves, magnetic switches etc. to be fitted to the cylinder itself. This solves many installation problems, especially where space is limited.

The modular system concept forms an ideal basis for additional customer-specific functions.

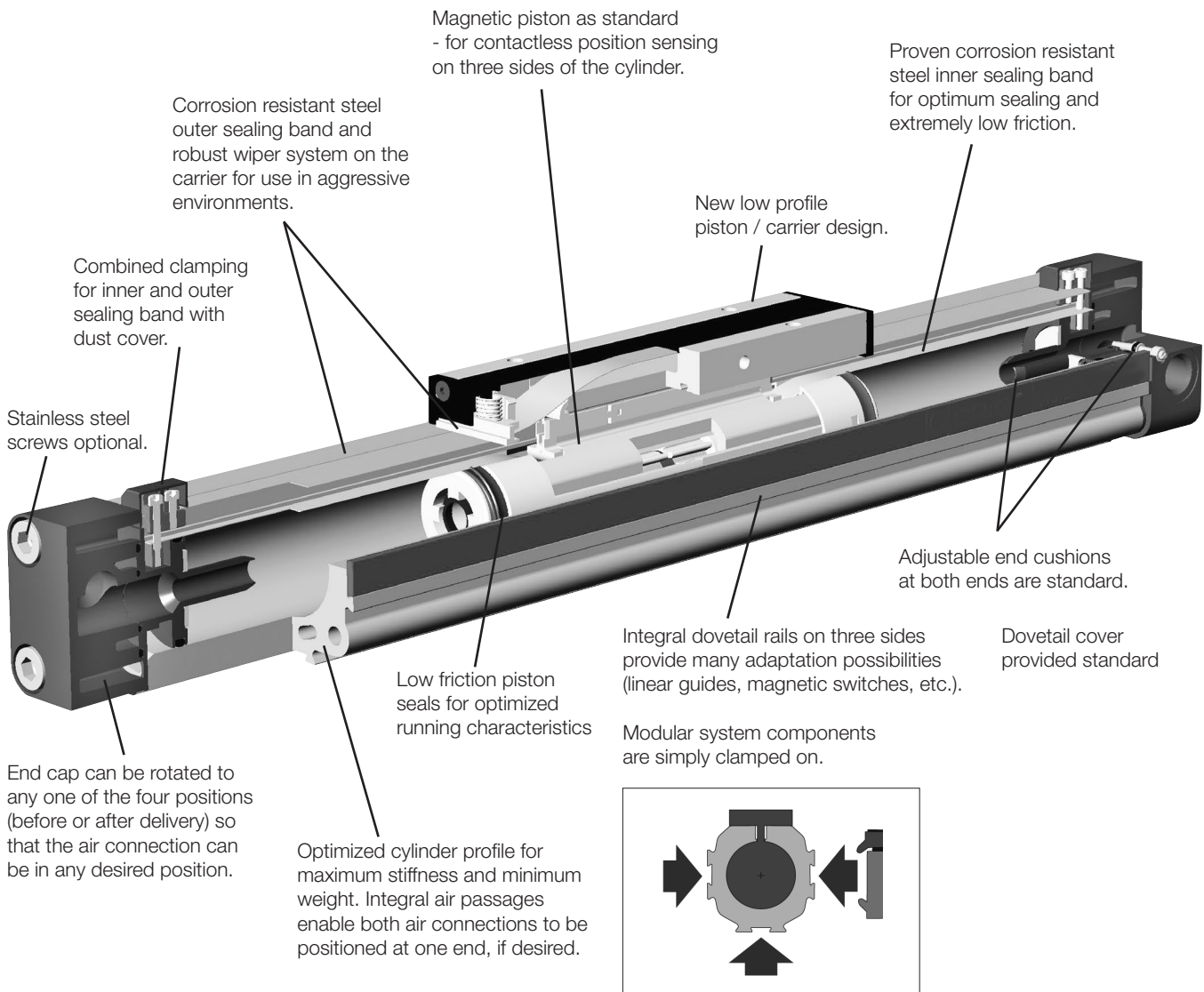

<b>G</b>
Rodless Pneumatic Cylinders
OSP-P Series
P1X Series
GDL Series



For inventory, lead times, and kit lookup, visit [www.pdnplu.com](http://www.pdnplu.com)

**Features**

**Standard Features:**

- Double-acting with adjustable cushions
- With magnetic piston for position sensing
- Standard stroke lengths to 5500mm, long stroke versions available upon request
- End cap can be rotated 4 x 90° to position ports as desired

**Optional Features:**

- Clean room cylinders
- Stainless steel screws
- 0.005 to 0.2 M/S
- Fluorocarbon seals -14°F to 212°F (-10°C to 100°C)
- Single end porting
- Integrated valves
- Integrated bearing options



**OSP**

**Operating information**

Operating pressure:	116 PSIG (8 bar)
Temperature range:	14°F to 176°F (-10°C to 80°C)
Filtration requirements:	Filtered, nonlubricated compressed air

**Specifications**

- Type: Rodless cylinder
- Series: OSP-P
- Stroke length: 5.5m (216 inches), Minimum 5mm
- System: Double-acting, with cushions and magnetic piston
- Mounting: See drawings
- Air connection: Threaded
- Weight (mass): See table
- Installation: In any position
- Lubrication: Prelubricated at the factory (additional oil mist lubrication not required)
- Option: special slow speed grease

**Material specifications**

Cylinder profile	Anodized aluminum
Carrier (piston)	Anodized aluminum
End caps	Aluminum, lacquered / plastic (P10)
Sealing bands	Corrosion resistant steel
Seals	NBR (Option: Fluorocarbon)
Screws	Galvanized steel Option: stainless steel
Dust covers, wipers	Composite

**Weight (mass) kg**

Cylinder Series (Basic cylinder)	Weight (Mass) kg	
	at 0mm Stroke	per 100mm Stroke
OSP-P10	0.087	0.052
OSP-P16	0.22	0.1
OSP-P25	0.65	0.197
OSP-P32	1.44	0.354
OSP-P40	1.95	0.415
OSP-P50	3.53	0.566
OSP-P63	6.41	0.925
OSP-P80	12.46	1.262

**Size Comparison**

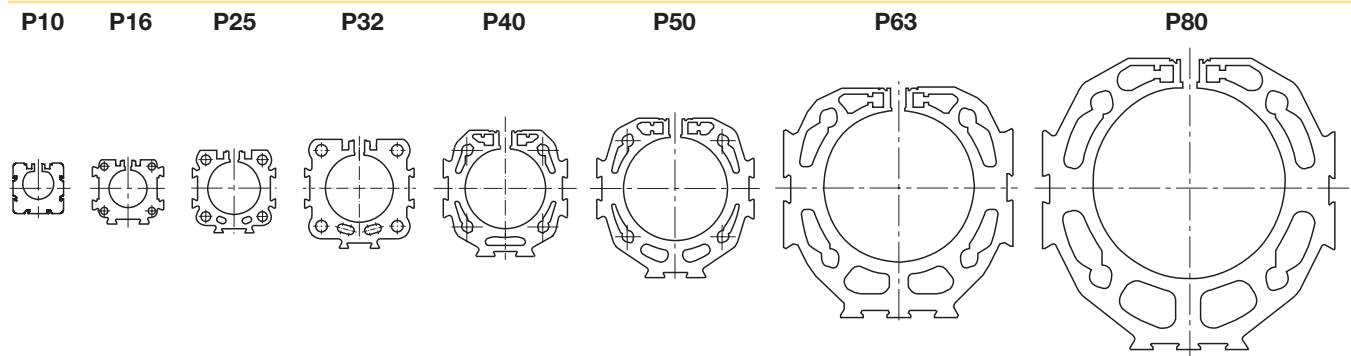

**G**  
 Rodless Pneumatic Cylinders  
 OSP-P Series  
 P1X Series  
 GDL Series



For inventory, lead times, and kit lookup, visit [www.pdnplu.com](http://www.pdnplu.com)

Ordering information for OSP-P rodless standard pneumatic series

1-4	5-6	7	8	9	10	11	12-16	17	18	19	20	21	22	23	24	25
<b>OSP</b>	<b>P</b>	<b>25</b>	<b>0</b>	<b>1</b>	<b>0</b>	<b>0</b>	<b>01100</b>	<b>0</b>	<b>0</b>	<b>0</b>	<b>0</b>	<b>0</b>	<b>0</b>	<b>1</b>	<b>0</b>	<b>0</b>
		<b>Bore</b>				<b>Lubrication</b>	<b>Stroke</b>	<b>Cushioning &amp; Stops</b>					<b>Dovetail Cover</b>	<b>Version</b>		
		10 16 25 32 40 50 63 80				0 Standard 1 Slow Speed 4 Food 5 Clean Room	xxxxx 5 digits in whole millimeters (ex. 1100mm = 01100)	0 Standard 1 Long Cushions (25,32,40)					0 Standard X Without Cover Rail	0 Standard		
		<b>Piston Style</b>				<b>Seals</b>			<b>Piston Mounting</b>				<b>Additional Carriages</b>			
		0 Standard 1 Tandem C Classic T Tandem Classic				0 Standard / Buna-N 1 Fluorocarbon			0 Standard 1 Floating Mount				0 None			
		<b>Porting Configurations†</b>				<b>Hardware</b>			<b>Guides / Brakes</b>					<b>Endcap Mounting</b>		
		0 Standard 1 End Face (16,25,32,40,50,63,80) 2 Single End Porting (25,32,40,50,63,80) 3 Left Std Pos #2, Right Pos #5 (16,25,32,40,50,63,80) 4 Left Pos #5, Right Std Pos #2 (16,25,32,40,50,63,80) 6 Single End Porting at #5 (50,63,80) 8 Inner Band Temp Compensation (25,32,40,80) A 24VDC VOE Valves (25,32,40,50) B 220VAC VOE Valves (25,32,40,50) C 48VDC VOE Valves (25,32,40,50) E 110VAC VOE Valves (25,32,40,50)				0 Standard / Zinc 1 Stainless Steel			0 None A Activebrake (16 thru 80) M Inversion (NR30) (16 thru 80mm bore only)					0 None 1 A1 (10,16,25,32) 2 A2 (16,25,32) 3 A3 (25,32) 4 B1 (25,32) 6 B3 (16) 7 B4 (25,32) 8 B5 (32) 9 C1 (40,50,63,80) A C2 (40,50,63,80) B C3 (40,50,63,80) C C4 (40,50,63,80)		
		Notes: 10mm bore can only have standard port locations. Single end porting on 16mm bore, then end caps cannot be rotated.							<b>Endcap Position</b>					Note: Comes in pairs		
									0 Both Pos #2 1 Both Pos #3 2 Both Pos #4 3 Both Pos #1 4 Left #3 / Right #2 5 Left #4 / Right #2 6 Left #1 / Right #2 7 Left #2 / Right #3 8 Left #4 / Right #3 9 Left #1 / Right #3 A Left #2 / Right #4 B Left #3 / Right #4 C Left #1 / Right #4 D Left #2 / Right #1 E Left #3 / Right #1 F Left #4 / Right #1					<b>Switches</b> ♦		
									Notes: 10mm bore only available on option "0".					0 None 1 Normally Open Reed Switch (16 thru 80) 2 Normally Closed Reed Switch (16 thru 80) 3 PNP Hall Sensor W/Extension Cables (16 thru 80) 4 NPN Hall Sensor W/Extension Cables (16 thru 80) 5 NO Reed, w/10mm Bracket (10 only) 6 PNP Hall Sensor w/Extension Cables & 10mm Brackets (10mm only) 7 NPN Hall Sensor w/Extension Cables & 10mm brackets (10mm only) X SFI 0.1mm RES (25 thru 80) Y SFI 1mm RES (25 thru 80)		
														♦ Note: 2 switches will be supplied. For different quantity, please order as a separate line item.		

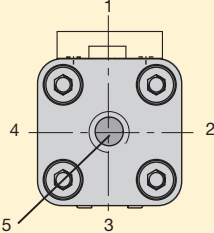

**Note: Position #2 is the standard location.**

† Single end ports can not be rotated in the field

**Sensors**  
See section L for sensors.



**G**  
Rodless Pneumatic Cylinders  
OSP-P Series  
P1X Series  
GDL Series

**Plain Bearing Guide SLIDELINE**

Available on 16 to 80mm bore

**Features:**

- Adjustable composite slide elements – optional integral brake
- Integrated sealing system with wiper elements to remove dirt and lubricate the slideways
- Any length of stroke up to 5500mm

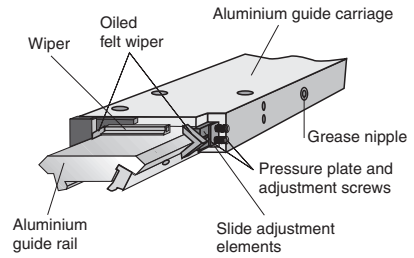

**Roller Guide POWERSLIDE**

Available on 16 to 50mm bore

**Features:**

- Anodized aluminum guide carriage with vee rollers
- Hardened steel guide rail
- Multiple guide sizes can be used on the same drive
- Max. Speed  $v = 3 \text{ m/s}$
- Integrated wiper and grease nipple
- Any length of stroke up to 3500mm

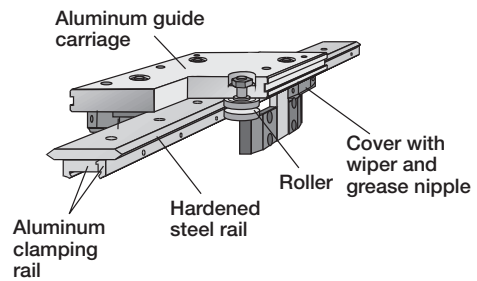
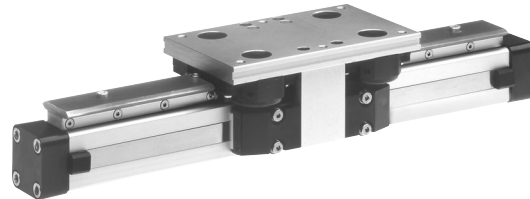

 <b>Rodless Pneumatic Cylinders</b>	OSP-P Series
	P1X Series
	GDL Series



**Other Options**



**PROLINE**

The compact aluminum roller guide for high loads and velocities and utilizes the GDL Guide Bearing



**Integrated VOE Valves**



**STARLINE**

Recirculating ball bearing guide for very high loads and precision



**SENSOFLEX SFI-plus**

Incremental measuring system with 0.1 (1.0) mm resolution

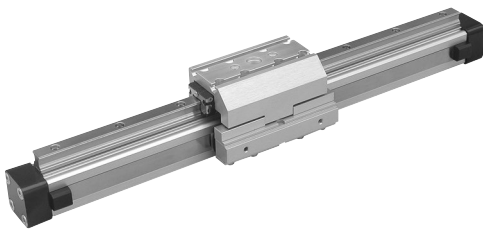

**KF Guide**

Recirculating ball bearing guide – the mounting dimensions correspond to FESTO Type: DGPL-KF



**Variable Stop VS**

The variable stop provides simple stroke limitation  
 Available on STARLINE, KF and Heavy duty guide



**Clean Room Version**

Certified to DIN EN ISO 14644-1

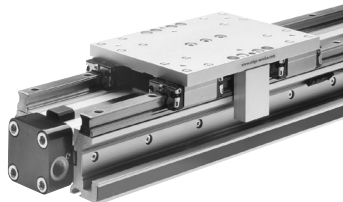

**Heavy Duty Guide HD**

For heavy duty applications

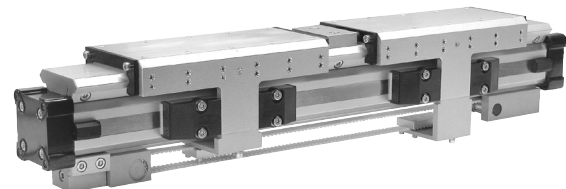

**Rodless Cylinder**

For synchronized bi-parting movements  
 Available on SLIDELINE Guide Bearing only

**G**

Rodless Pneumatic  
 Cylinders

OSP-P  
 Series

P1X  
 Series

GDL  
 Series



For inventory, lead times, and kit lookup, visit [www.pdnplu.com](http://www.pdnplu.com)

**Loads, Forces and Moments**

When sizing an OSP cylinder, consideration must be given to:

- Loads, forces and moments
- Performance of the pneumatic end cushions. The main factors are the mass to be cushioned and the piston speed (unless external cushioning is used, e. g. hydraulic shock absorbers)

To determine the maximum values for light, shock-free operation, which must not be exceeded even in dynamic operation.

**Load and moment data are based on speeds  $v \leq 0.5$  m/s.**

When working out the action force required, it is essential to take into account the friction forces generated by the specific application or load.

The sum total of each of these types of moments, divided by each of the maximum values, determines a Load-Moment Factor (LMF) should be equal to or less than 1.0. On horizontal mountings, the total load (L) should also be divided by the maximum load allowable and factored into the equation.

**Horizontal Mountings:**

$$\frac{L}{[L]} + \frac{M}{[M]} + \frac{M_s}{[M_s]} + \frac{M_v}{[M_v]} = LMF \leq 1.0$$

**Vertical Mountings:**

$$\frac{M}{[M]} + \frac{M_s}{[M_s]} + \frac{M_v}{[M_v]} = LMF \leq 1.0$$

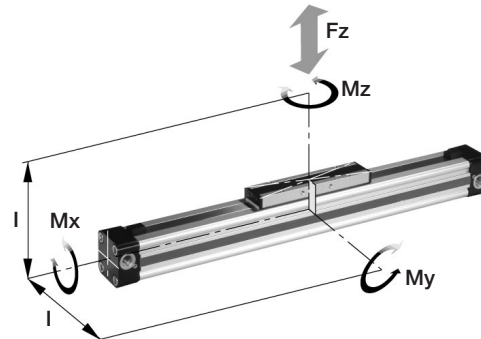

$$M = F \cdot l$$

Bending moments are calculated from the center of the linear actuator

Cylinder Series (mm Ø)	Theoretical Output Force at 6 bar N (lb)	Actual Output Force $F_A$ at 6 bar N (lb)	Max. Moments			Max. Load F N (lb)	Cushion Length (mm)
			$M_x$ Nm (in lb)	$M_y$ Nm (in lb)	$M_z$ Nm (in lb)		
OSP-P10	47 (10.6)	32 (7.2)	0.2 (1.8)	1 (8.9)	0.3 (2.7)	20 (4.5)	2.5 * (.09)
OSP-P16	120 (26.9)	78 (17.5)	0.45 (3.9)	4 (35.4)	0.5 (4.4)	120 (26.9)	11 (.43)
OSP-P25	295 (66.3)	250 (56.2)	1.5 (13.3)	15 (132.8)	3 (26.6)	300 (67.4)	17 (.67)
OSP-P32	483 (108.6)	420 (94.4)	3 (26.6)	30 (265.5)	5 (44.3)	450 (101.2)	20 (.79)
OSP-P40	754 (169.5)	640 (143.9)	6 (53.1)	60 (531)	8 (70.8)	750 (168.6)	27 (1.06)
OSP-P50	1178 (264.8)	1000 (224.8)	10 (88.5)	115 (1017.8)	15 (132.8)	1200 (269.8)	30 (1.18)
OSP-P63	1870 (420.4)	1550 (348.5)	12 (106.2)	200 (1771)	24 (212.4)	1650 (370.9)	32 (1.26)
OSP-P80	3016 (678)	2600 (584.5)	24 (212.4)	360 (3186)	48 (424.8)	2400 (539.5)	39 (1.54)

\* A rubber element (non-adjustable) is used for end cushioning.  
 To deform the rubber element enough to reach the absolute end position would require a  $\Delta p$  of 4 bar!

**Cushioning diagram**

Determine the moving mass and follow the chart below to determine the maximum cylinder velocity.

Alternatively, take your desired velocity and moving mass to determine the required cylinder diameter.

If these maximum permissible values are exceeded, additional shock absorbers must be used.

For sizing a basic cylinder, use the adjacent chart. To size a cylinder with guide bearing, use the charts on the following page.

The peak piston velocity can be determined by assuming it is 50% greater than the average velocity. The peak velocity should be used in sizing the cylinder cushions.

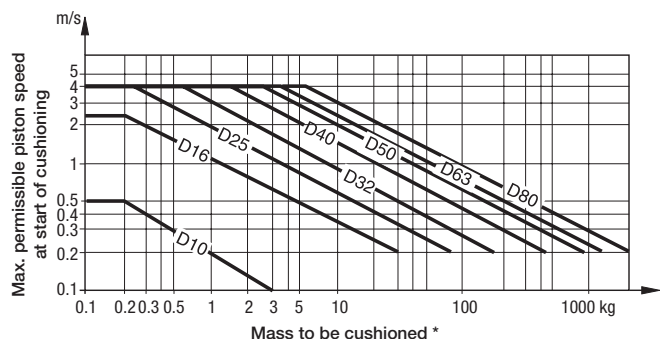

Includes piston mass.

\* For cylinders with linear guides or brakes, please be sure to take the mass of the carriage or the brake housing into account.

**G**  
 Rodless Pneumatic Cylinders  
 OSP-P Series  
 P1X Series  
 GDL Series



For inventory, lead times, and kit lookup, visit [www.pdnplu.com](http://www.pdnplu.com)



**Mid-Section Supports**

To avoid excessive bending and oscillation of the cylinder, intermediate supports may be required. The diagrams below show the maximum permissible support spacing based upon load.

Bending up to 0.5 mm is permissible between supports. The mid-section supports are clamped on to the dovetail profile of the cylinder tube. They are also able to take the axial forces.

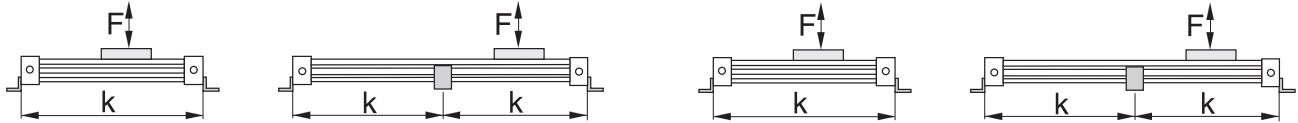

**Basic cylinder 10 to 32mm bore mid-section supports**

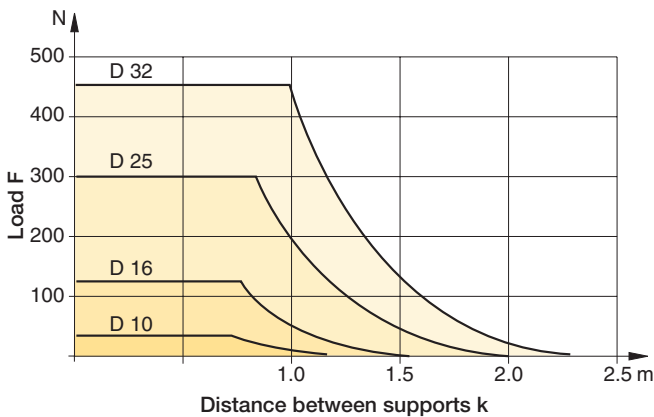

**Basic cylinder 40 to 80mm bore mid-section supports**

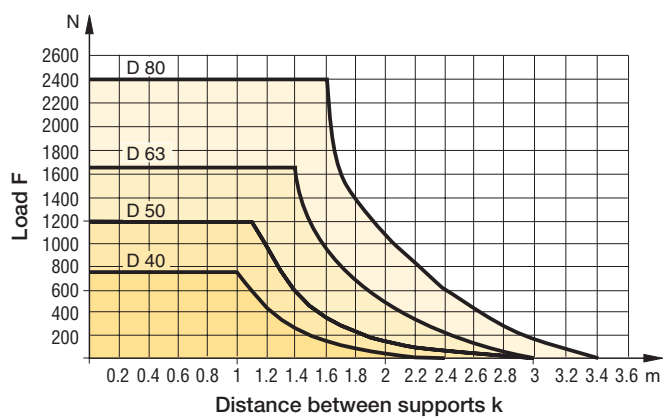

**G**

Rodless Pneumatic Cylinders

---

OSP-P Series

---

P1X Series

---

GDL Series

**Cylinder Stroke and Dead Length A**

- Free choice of stroke length up to 5500mm in 1mm steps.
- Longer strokes available on request.

**Tandem Cylinder**

Two pistons are fitted : dimension "Z" is optional. Please note minimum distance "Zmin".

- Free choice of stroke length up to 5500mm in 1mm steps.
- Longer strokes available on request.
- Stroke length to order is stroke + dimension "Z".

**Please note:**

**To avoid multiple actuation of magnetic switches, the second piston is not equipped with magnets.**

**Basic cylinder – 10mm bore**

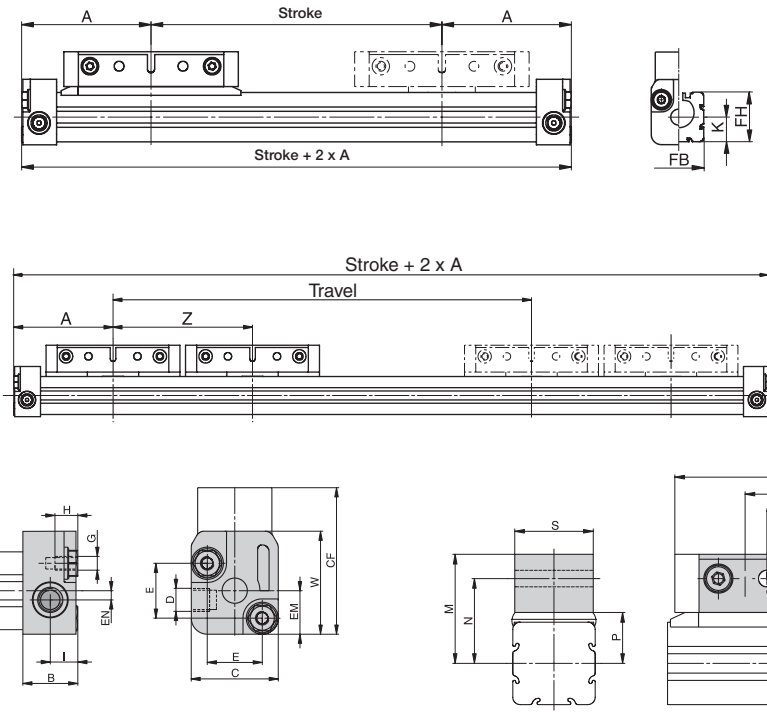

**Dimensions (mm)**

Series	A	B	C	D	E	G	H	I	J	K	L	M	N	P	R	S	W	X	Y	Zmin	CF	EM	EN	FB	FH	ZZ
OSP-P10	44.5	12	19	M5	12	M3	5	6	60	8.5	22	22.5	17.5	10.5	3.4	16	22.5	31	M3	64	32	9.5	2	17	17	6

**G**  
 Rodless Pneumatic Cylinders  
 OSP-P Series  
 P1X Series  
 GDL Series



For inventory, lead times, and kit lookup, visit [www.pdnplu.com](http://www.pdnplu.com)

**Cylinder Stroke and Dead Length A**

- Free choice of stroke length up to 5500mm in 1mm steps.
- Longer strokes available on request.

**Tandem Cylinder**

- Two pistons are fitted : dimension “Z” is optional. Please note minimum distance “Zmin”.
- Free choice of stroke length up to 5500mm in 1mm steps.
  - Longer strokes available on request.
  - Stroke length to order is stroke + dimension “Z”.

**Please note:**  
**To avoid multiple actuation of magnetic switches, the second piston is not equipped with magnets.**

**Basic cylinder – 16 to 80mm bore**

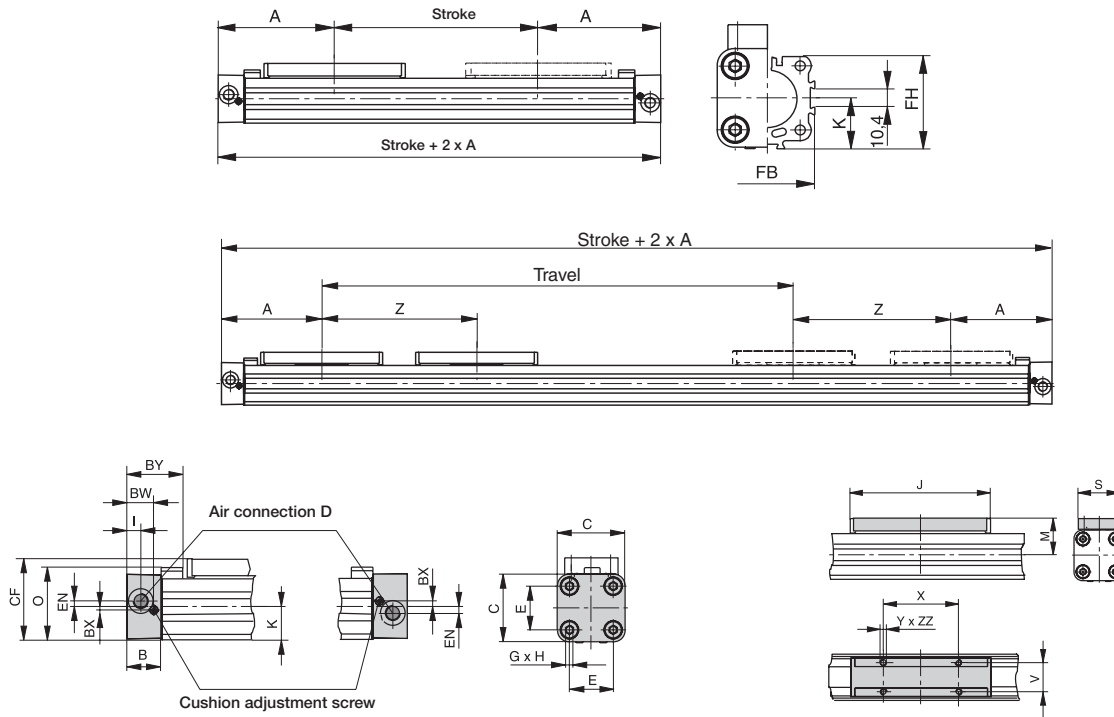

**Dimensions (mm)**

Series	A	B	C	D	E	G	H	I	J	K	M	O	S	V	X	Y	Z	BW	BX	BY	CF	EN	FB	FH	ZZ
OSP-P16	65	14	30	M5	18	M3	9	5.5	69	15	23	33.2	22	16.5	36	M4	81	10.8	1.8	28.4	38	3	30	27.2	7
OSP-P25	100	22	41	G1/8	27	M5	15	9	117	21.5	31	47	33	25	65	M5	128	17.5	2.2	40	52.5	3.6	40	39.5	8
OSP-P32	125	25.5	52	G1/4	36	M6	15	11.5	152	28.5	38	59	36	27	90	M6	170	20.5	2.5	44	66.5	5.5	52	51.7	1
OSP-P40	150	28	69	G1/4	54	M6	15	12	152	34	44	72	36	27	90	M6	212	21	3	54	78.5	7.5	62	63	10
OSP-P50	175	33	87	G1/4	70	M6	15	14.5	200	43	49	86	36	27	110	M6	251	27	-	59	92.5	11	76	77	10
OSP-P63	215	38	106	G3/8	78	M8	21	14.5	256	54	63	107	50	34	140	M8	313	30	-	64	117	12	96	96	16
OSP-P80	260	47	132	G1/2	96	M10	25	22	348	67	80	133	52	36	190	M10	384	37.5	-	73	147	16.5	122	122	20

**G**  
 Rodless Pneumatic Cylinders  
 OSP-P Series  
 P1X Series  
 GDL Series



For inventory, lead times, and kit lookup, visit [www.pdnplu.com](http://www.pdnplu.com)

**Air Connection on the End-Face #5**

In some situations it is necessary or desirable to fit a special end cap with the air connection on the end-face instead of the standard end cap with the air connection on the side. The special end cap can also be rotated 4 x 90° to locate the cushion adjustment screw as desired.



**Series OSP-P16 to P32**

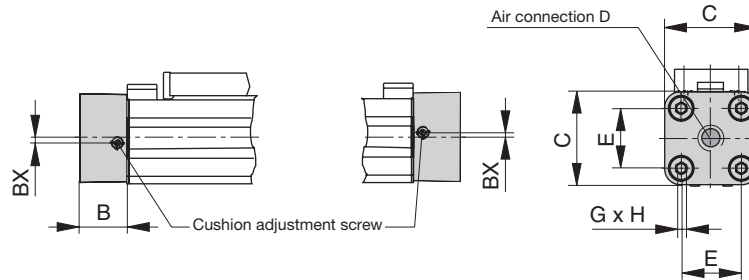

**Series OSP-P40 to P80**

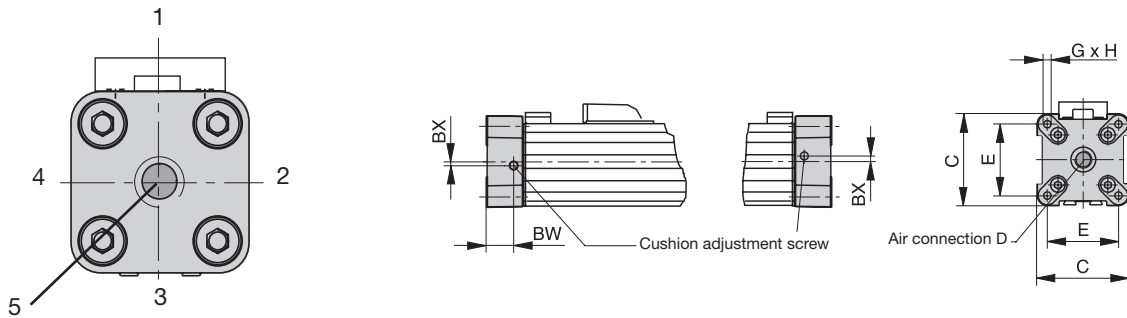

**Note: Position #2 is the standard location.**

**Dimension (mm)**

Series	B	C	D	E	G	H	BX	BW
OSP-P16	14	30	M5	18	M3	9	1.8	10.8
OSP-P25	22	41	G1/8	27	M5	15	2.2	17.5
OSP-P32	25.5	52	G1/4	36	M6	15	2.5	20.5
OSP-P40	28	69	G1/4	54	M6	15	3	21
OSP-P50	33	87	G1/4	70	M6	15	-	27
OSP-P63	38	106	G3/8	78	M8	21	-	30
OSP-P80	47	132	G1/2	96	M10	25	-	37.5

**G**  
 Rodless Pneumatic Cylinders  
 OSP-P Series  
 P1X Series  
 GDL Series



For inventory, lead times, and kit lookup, visit [www.pdnplu.com](http://www.pdnplu.com)

**Single End Porting**

A special end cap with both air connections on one side is available for situations where shortage of space, simplicity of installation or the nature of the process make it desirable. Air supply to the other end is via internal air passages (OSP-P25 to P80).

In this case the end caps cannot be rotated.



**Series OSP-P25**

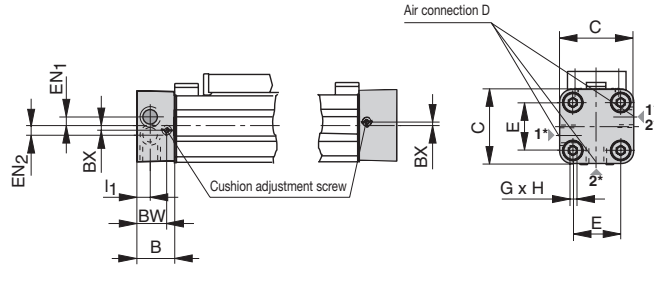

\* Versions of Air Connection  
 Positions: 1 → 1 or  
 2 → 2

**Series OSP-P32 to P80**

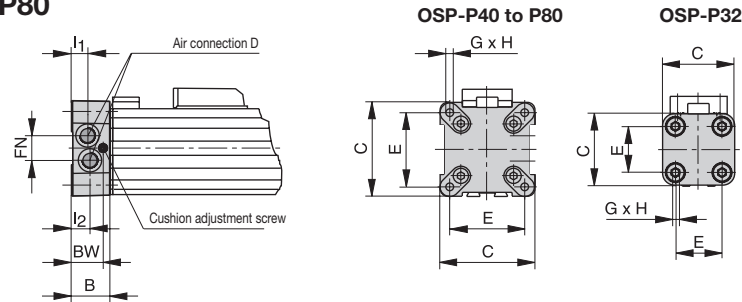

**Dimension (mm)**

Series	B	C	D	E	G	H	I1	I2	BX	BW	EN	EN1	EN2	FA	FB	FC	FE	FG	FL	FN
OSP-P25	22	41	G1/8	27	M5	15	9	-	2.2	17.5	-	3.6	3.9	-	-	-	-	-	-	-
OSP-P32	25.5	52	G1/8	36	M6	15	12.2	10.5	-	20.5	-	-	-	-	-	-	-	-	-	15.2
OSP-P40	28	69	G1/8	54	M6	15	12	12	-	21	-	-	-	-	-	-	-	-	-	17
OSP-P50	33	87	G1/4	70	M6	15	14.5	14.5	-	-	-	-	-	-	-	-	-	-	-	22
OSP-P63	38	106	G3/8	78	M8	21	16.5	13.5	-	30	-	-	-	-	-	-	-	-	-	25
OSP-P80	47	132	G1/2	96	M10	25	22	17	-	37.5	-	-	-	-	-	-	-	-	-	34.5

**G**

Rodless Pneumatic Cylinders

OSP-P Series

P1X Series

GDL Series



For inventory, lead times, and kit lookup, visit [www.pdnplu.com](http://www.pdnplu.com)

**Integrated 3/2 Way Valves VOE Series OSP-P25, P32, P40 and P50**

For optimal control of the OSP-P cylinder, 3/2 way valves integrated into the cylinder's end caps can be used as a compact and complete solution.

They allow for easy positioning of the cylinder, smooth operation at the lowest speeds and fast response, making them ideally suited for the direct control of production and automation processes.

**Characteristics:**

- Complete compact solution
- Various connection possibilities:  
 Free choice of air connection with rotating end caps with VOE valves, Air connection can be rotated 4 x 90°, Solenoid can be rotated 4 x 90°, Pilot Valve can be rotated 180°
- High piston velocities can be achieved with max. 3 exhaust ports
- Minimal installation requirements
- Requires just one air connection per valve
- Optimal control of the OSP-P cylinder
- Excellent positioning characteristics
- Integrated operation indicator
- Integrated exhaust throttle valve
- Manual override - indexed
- Adjustable end cushioning
- Easily retrofitted – please note the increase in the overall length of the cylinder!

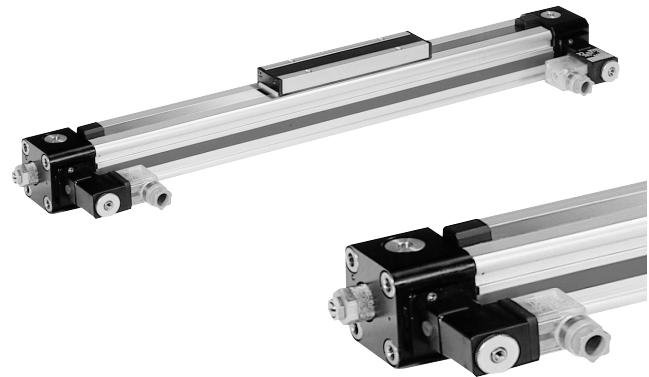

**Operating information**

Operating pressure:	116 PSIG (8 bar)
Temperature range:	-14°F to 122°F (10°C to 50°C)
Filtration requirements:	Filtered, nonlubricated compressed air

**Specifications**

- Characteristics 3/2 Way Valves with spring return electrical
- Actuation electrical
- Basic position P → A open, R closed
- Type Poppet valve, non overlapping
- Mounting integrated in end cap
- Installation in any position
- Port size G 1/8 VOE-25 G 1/4 VOE-32  
 G 3/8 VOE-40 G 3/8 VOE-50
- Temperature -10°C to 50°C \*
- Operating pressure 2-8 bar
- Nominal voltage 24 V DC / 230 V AC, 50 Hz
- Power consumption 2,5 W / 6 VA
- Duty cycle 100%
- Electrical Protection IP65 DIN 40050

\* Other temperature ranges on request

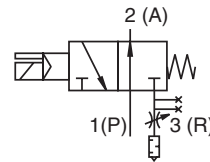

**VOE-25 / VOE-32**

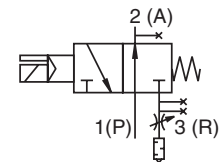

**VOE-40 / VOE-50**

**VOE Flow**

<b>25mm</b>	14.8 CFM	0.47 Cv
<b>3225mm</b>	18.7 CFM	0.59 Cv
<b>40mm</b>	70.6 CFM	2.23 Cv
<b>50mm</b>	77.7 CFM	2.46 Cv

**G**  
 Rodless Pneumatic Cylinders  
 OSP-P Series  
 P1X Series  
 GD L Series



For inventory, lead times, and kit lookup, visit [www.pdnplu.com](http://www.pdnplu.com)

**Dimensions VOE Valves OSP-P25 and P32**

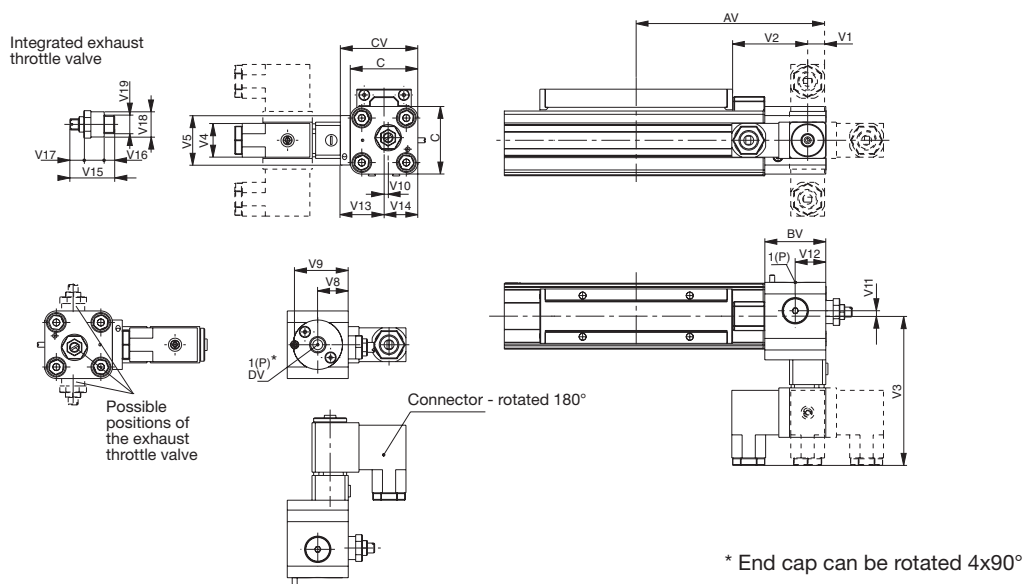

**Dimension (mm)**

Series	AV	BV	C	CV	DV	V1	V2	V3	V4	V5	V8	V9	V10	V11	V12	V13	V14	V15	V16	V17	V18	V19
OSP-P25	115	37	41	47	G1/8	11	46	90.5	22	30	18.5	32.5	2.5	3.3	18.5	26.5	20.5	24	5	4	14	G1/8
OSP-P32	139	39.5	52	58	G1/4	20.5	46	96	22	32	20.5	34.7	6	5	20.5	32	26	32	7.5	6	18	G1/4

**Dimensions VOE Valves OSP-P40 and P50**

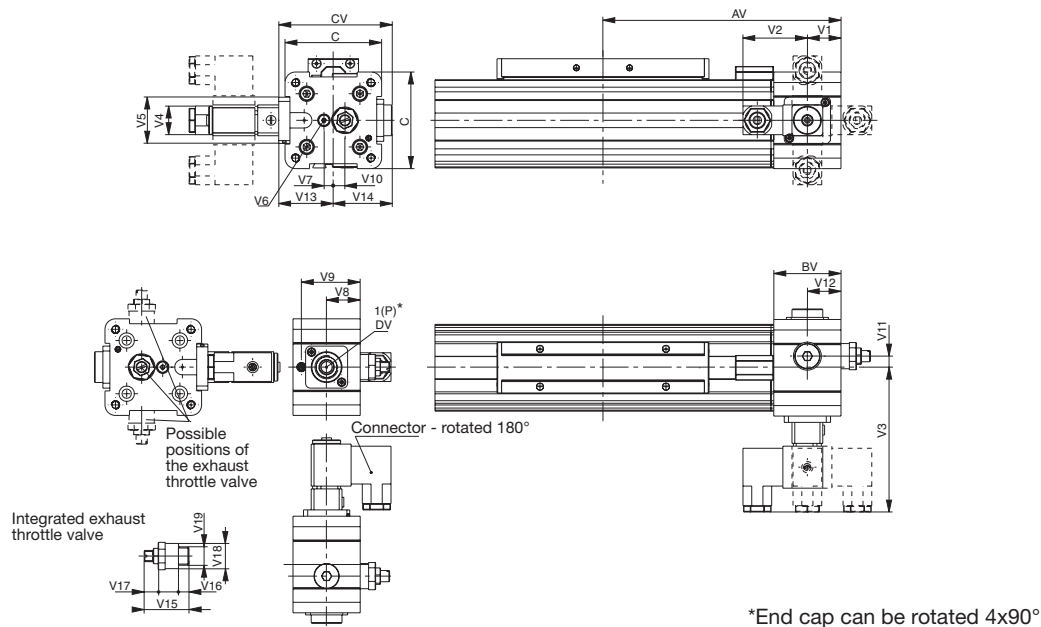

**Dimension (mm)**

Series	AV	BV	C	CV	DV	V1	V2	V3	V4	V5	V6	V7	V8	V9	V10	V11	V12	V13	V14	V15	V16	V17	V18	V19
OSP-P40	170	48	69	81	G3/8	24	46	103	22	33	M5	6.7	24	42	8.3	8.3	24	39	42	32	7.5	6	18	G1/4
OSP-P50	190	48	87	82	G3/8	24	46	102	22	33	M5	4.5	24	42	12.2	12.2	24	38	44	32	7.5	6	18	G1/4

**G**  
 Rodless Pneumatic Cylinders  
 OSP-P Series  
 P1X Series  
 GDL Series



For inventory, lead times, and kit lookup, visit [www.pdnplu.com](http://www.pdnplu.com)

**Active Brake**

**Series AB 25 to 80 for linear drive**

- Series OSP-P
- Can be used with Sensoflex

**Features:**

- Actuated by pressurization
- Released by spring actuation
- Completely stainless version
- Holds position, even under changing load conditions



**OSP**

For further technical data, please refer to the data sheets for linear drives OSP-P (page G77)

**Note:**

For combinations Active Brake AB + SFI-plus + Magnetic Switch contact our technical department please.

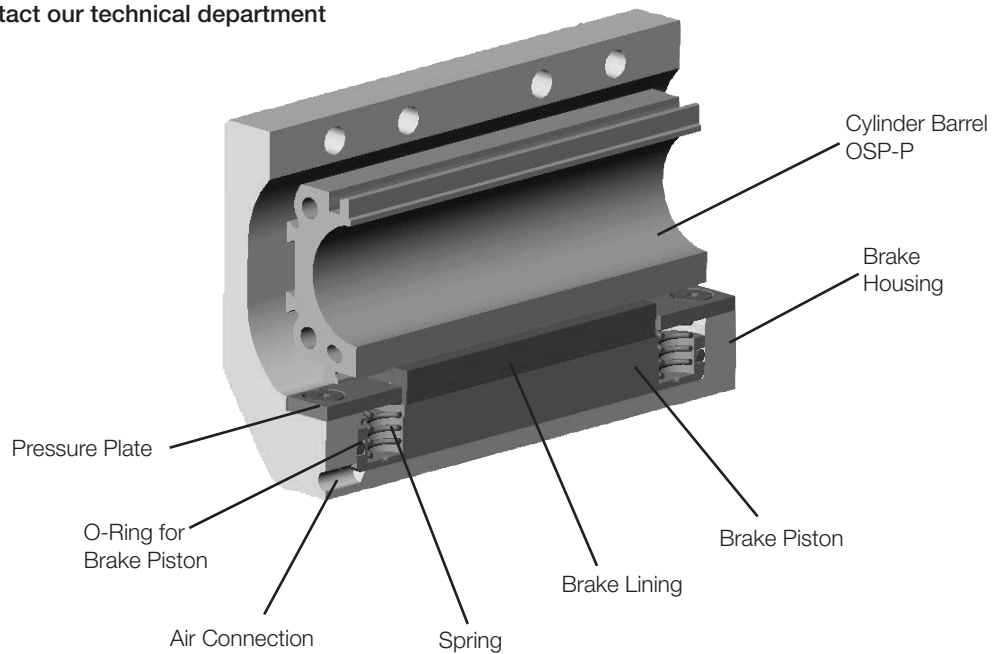

**Forces and Weights**

Series	For Linear Drive	Max. Braking Force (N) †	Brake Pad Way (mm)	Mass (kg)			Part Number Active Brake (includes carriage)	Air Connection
				Linear Drive with Brake		Brake*		
				0 mm Stroke	Increase per 100mm Stroke			
AB 25	OSP-P25	350	2.5	1.0	0.197	0.35	<b>20806FIL</b>	M5
AB 32	OSP-P32	590	2.5	2.02	0.354	0.58	<b>20807FIL</b>	M5
AB 40	OSP-P40	900	2.5	2.83	0.415	0.88	<b>20808FIL</b>	M5
AB 50	OSP-P50	1400	2.5	5.03	0.566	1.50	<b>20809FIL</b>	M5
AB 63	OSP-P63	2170	3.0	9.45	0.925	3.04	<b>20810FIL</b>	G 1/8
AB 80	OSP-P80	4000	3.0	18.28	1.262	5.82	<b>20811FIL</b>	G 1/8

† – at 6 bar both chambers pressurized with 6 bar Braking surface dry  
 – oil on the braking surface will reduce the braking force

**\* Please Note:**

The mass of the brake has to be added to the total moving mass when using the cushioning diagram.

**G**  
 Rodless Pneumatic Cylinders  
 OSP-P Series  
 P1X Series  
 GDL Series



For inventory, lead times, and kit lookup, visit [www.pdnplu.com](http://www.pdnplu.com)



**Series OSP-P25 and P32 with Active Brake AB**

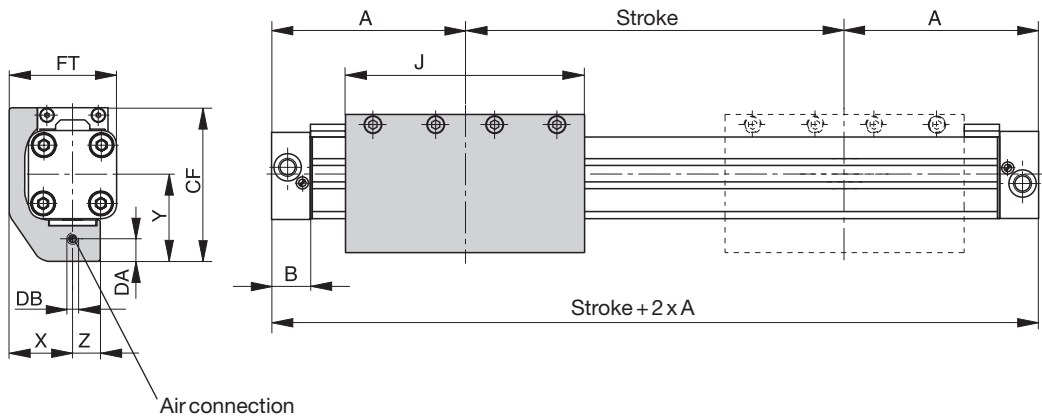

**Series OSP-P40, P50, P63, P80 with Active Brake AB**

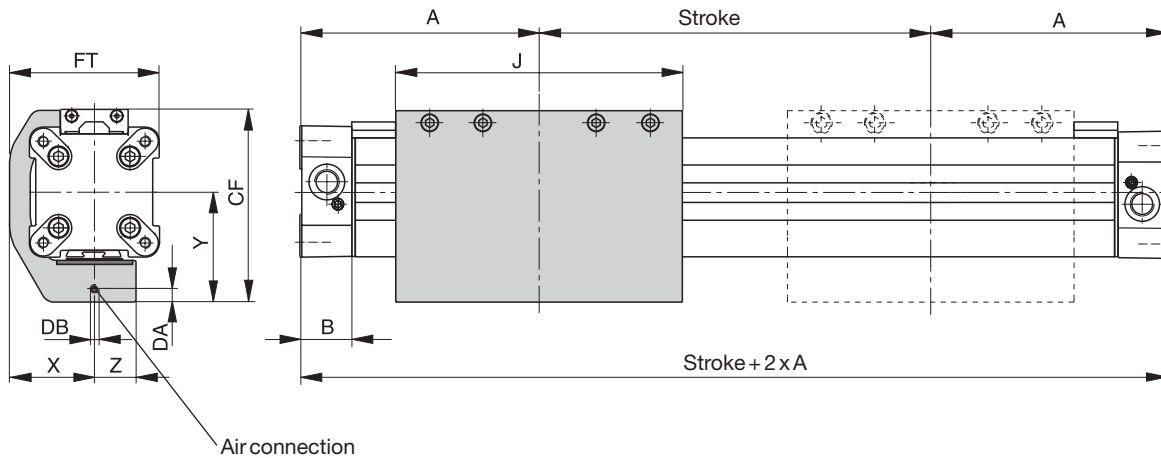

**Dimension (mm)**

Series	A	B	J	X	Y	Z	CF	DA	DB	FT
AB 25	100	22	117	29.5	43	13	74	4	M5	50
AB 32	125	25.5	151.4	36	50	15	88	4	M5	62
AB 40	150	28	151.4	45	58	22	102	7	M5	79.5
AB 50	175	33	200	54	69.5	23	118.5	7.5	M5	97.5
AB 63	215	38	256	67	88	28	151	9	G1/8	120
AB 80	260	47	348	83	105	32	185	10	G1/8	149

**G**

Rodless Pneumatic  
Cylinders

---

OSP-P  
Series

---

P1X  
Series

---

GDL  
Series



For inventory, lead times, and kit lookup, visit [www.pdnplu.com](http://www.pdnplu.com)

**End Cap Mountings**

On the end-face of each cylinder end cap there are four threaded holes for mounting the cylinder. The hole layout is square, so that the mounting can be fitted to the bottom, top or either side.

**Series OSP – P25 and P32 with Active Brake AB: Type A3**

**Material:**

Galvanized steel

The mountings are supplied in pairs.

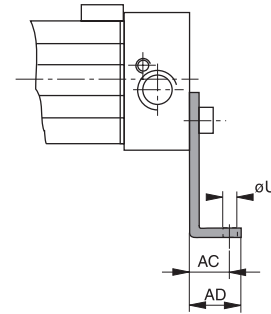
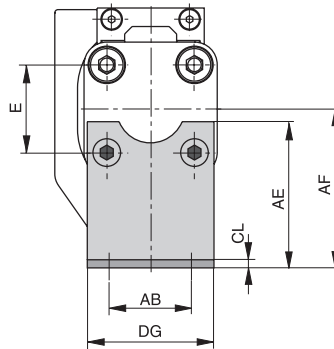
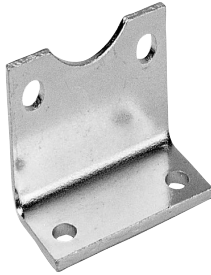

**Series OSP – P40 , P50, P63, P80 with Active Brake AB: Type C3**

**Material:**

Anodized aluminum

The mountings are supplied in pairs.

Stainless steel version on request.

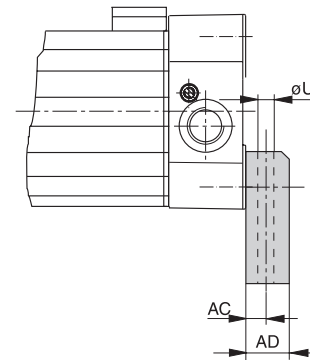
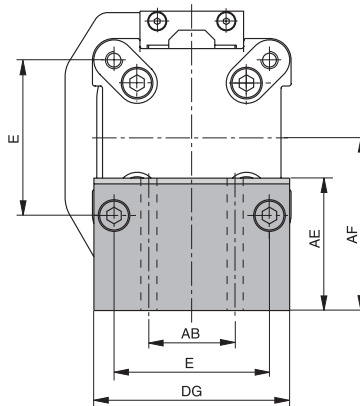
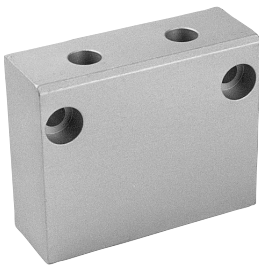

**Dimension (mm)**

Series	E	øU	AB	AC	AD	AE	AF	CL	DG	Part Number	
										Type A3	Type C3
AB 25	27	5.8	27	16	22	45	49	2.5	39	2060FIL	-
AB 32	36	6.6	36	18	26	42	52	3	50	3060FIL	-
AB 40	54	9	30	12.5	24	46	60	-	68	-	20339FIL
AB 50	70	9	40	12.5	24	54	72	-	86	-	20350FIL
AB 63	78	11	48	15	30	76	93	-	104	-	20821FIL
AB 80	96	14	60	17.5	35	88	110	-	130	-	20822FIL

**G**  
 Rodless Pneumatic Cylinders  
 OSP-P Series  
 P1X Series  
 GDL Series



For inventory, lead times, and kit lookup, visit [www.pdnplu.com](http://www.pdnplu.com)

**Mid-Section Supports**

Mid-section supports are required from a certain stroke length to prevent excessive deflection and vibration of the linear drive.

The diagrams show the maximum permissible unsupported length in relation to loading. Deflection of 0.5mm max. between supports is permissible.

The Mid-Section supports are attached to the dovetail rails, and can take axial loads.

**Note to Type E3:**

Mid-Section supports can only be mounted opposite of the brake housing.

Stainless steel version available on request.

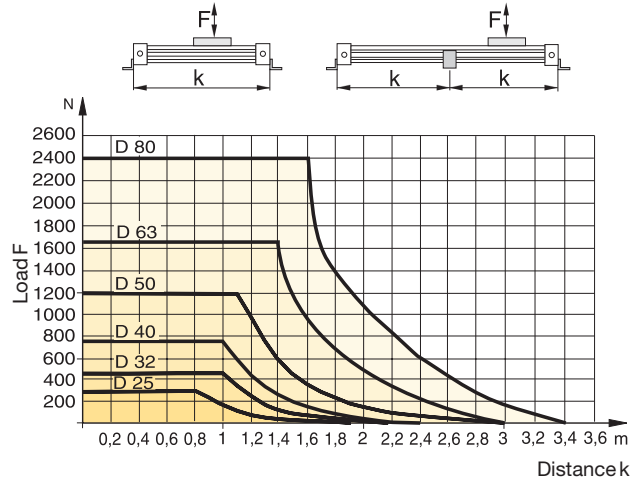

**Series OSP-P25 to P80 with Active Brake AB: Type E3**

(Mounting from above / below with through-bolt)

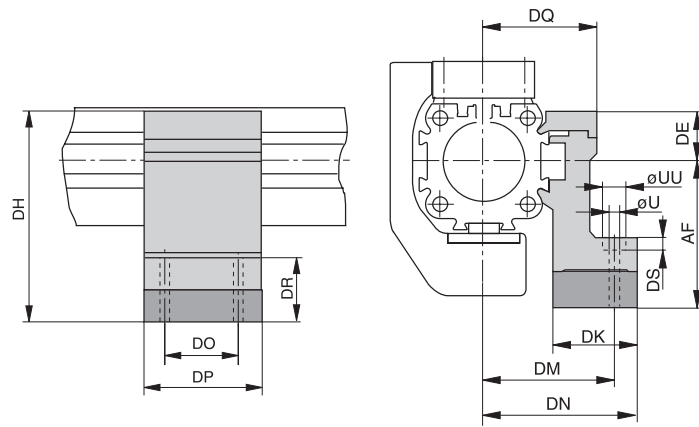

**Dimension (mm)**

Series	U	UU	AF	DE	DH	DK	DM	DN	DO	DP	DQ	DR	DS	Type E3 Part Number
AB 25	5.5	10	49	16	65	26	40	47.5	36	50	34.5	35	5.7	20353FIL
AB 32	5.5	10	52	16	68	27	46	54.5	36	50	40.5	32	5.7	20356FIL
AB 40	7	-	60	23	83	34	53	60	45	60	45	32	-	20359FIL
AB 50	7	-	72	23	95	34	59	67	45	60	52	31	-	20362FIL
AB 63	9	-	93	34	127	44	73	83	45	65	63	48	-	20453FIL
AB 80	11	-	110	39.5	149.5	63	97	112	55	80	81	53	-	20819FIL

**G**  
 Rodless Pneumatic Cylinders  
 OSP-P Series  
 P1X Series  
 GDL Series



For inventory, lead times, and kit lookup, visit [www.pdnplu.com](http://www.pdnplu.com)

**Clevis Mount  $\varnothing$  10mm**

**For Linear-drive**

- Series OSP-P



When external guides are used, parallelism deviations can lead to mechanical strain on the piston. This can be avoided by the use of a clevis mounting.

In the drive direction, the mounting has very little play.

Freedom of movement is provided as follows:

- Tilting in direction of movement
- Vertical compensation
- Tilting sideways
- Horizontal compensation

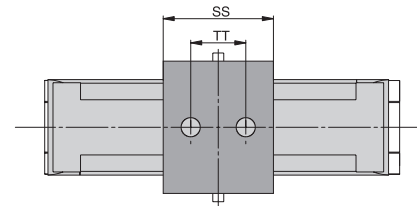
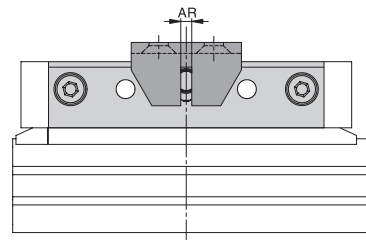
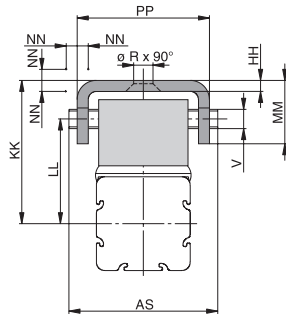
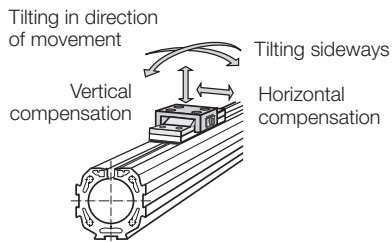

**Dimension (mm)**

Series	$\varnothing$ R	V	AR	AS	HH	KK	LL	MM	NN*	PP	SS	TT	Part Number	
													Standard	Stainless
OSP-P10	3.4	3.5	2	27	2	26	19	11.5	1	24	20	10	20971FIL	-

\* Dimension NN gives the possible plus and minus play in horizontal and vertical movement, which also makes tilting sideways possible.

G	Rodless Pneumatic Cylinders
OSP-P	Series
P1X	Series
GDL	Series



For inventory, lead times, and kit lookup, visit [www.pdnplu.com](http://www.pdnplu.com)

**Clevis Mount  $\varnothing$  16 to 80mm**

**For Linear-drive**

- Series OSP-P

When external guides are used, parallelism deviations can lead to mechanical strain on the piston. This can be avoided by the use of a clevis mounting.

In the drive direction, the mounting has very little play.

Freedom of movement is provided as follows:

- Tilting in direction of movement
- Vertical compensation
- Tilting sideways
- Horizontal compensation

A stainless steel version is also available.

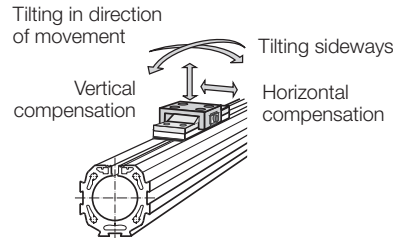
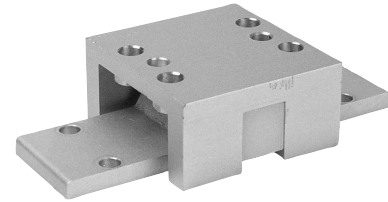

**Please note:**  
 When using additional inversion mountings, take into account the dimensions in page G28.

**Series OSP-P16 to 32**

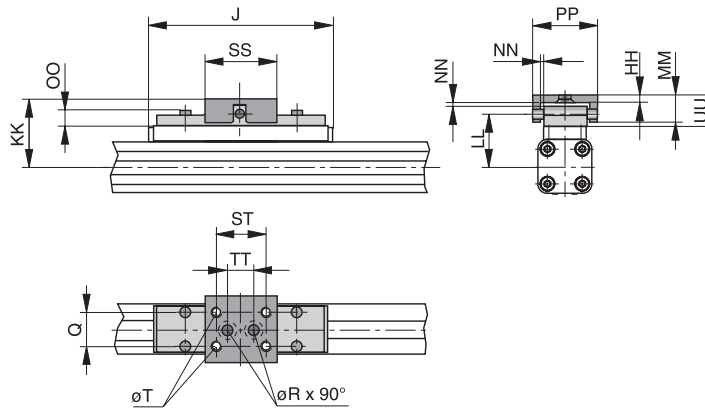

**Series OSP-P40 to 80**

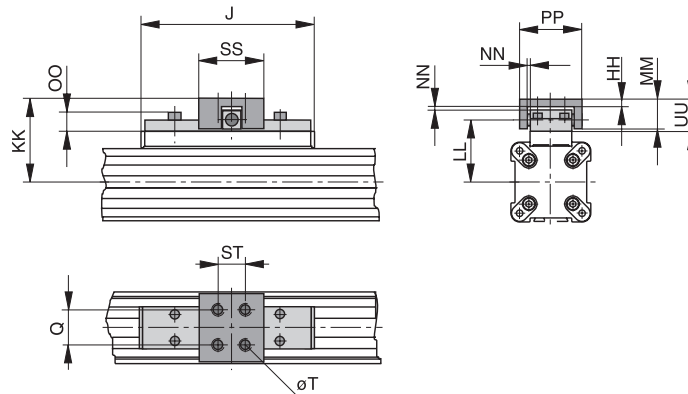

Dimension (mm)

Series	J	Q	T	$\varnothing R$	HH	KK	LL	MM	NN*	OO	PP	SS	ST	TT	UU	Part Number	
																Standard	Stainless
OSP-P16	69	10	M4	4.5	3	34	26.6	10	1	8.5	26	28	20	10	11	20462FIL	20463FIL
OSP-P25	117	16	M5	5.5	3.5	52	39	19	2	9	38	40	30	16	21	20005FIL	20092FIL
OSP-P32	152	25	M6	6.6	6	68	50	28	2	13	62	60	46	40	30	20096FIL	20094FIL
OSP-P40	152	25	M6	-	6	74	56	28	2	13	62	60	46	-	30	20024FIL	20093FIL
OSP-P50	200	25	M6	-	6	79	61	28	2	13	62	60	46	-	30	20097FIL	20095FIL
OSP-P63	256	37	M8	-	8	100	76	34	3	17	80	80	65	-	37	20466FIL	20467FIL
OSP-P80	348	38	M10	-	8	122	96	42	3	16	88	90	70	-	42	20477FIL	20478FIL

\* Dimension NN gives the possible plus and minus play in horizontal and vertical movement, which also makes tilting sideways possible.



For inventory, lead times, and kit lookup, visit [www.pdnplu.com](http://www.pdnplu.com)

**Inversion Mount ø 16 to 80mm**

For Linear-drive

- Series OSP-P



In dirty environments, or where there are special space problems, inversion of the cylinder is recommended.

The inversion bracket transfers the driving force to the opposite side of the cylinder. The size and position of the mounting holes are the same as on the standard cylinder.

**Please note:**

Other components of the OSP system such as mid-section supports, magnetic switches and the external air passage for the P16, can still be mounted on the free side of the cylinder.

When combining single end porting with inversion mountings,

RS magnetic switches can only be mounted directly opposite to the external air-supply profile.

**Important Note:**

May be used in combination with Clevis Mounting, reference dimensions in pages G32-G33.

**Series OSP-P16 to 32**

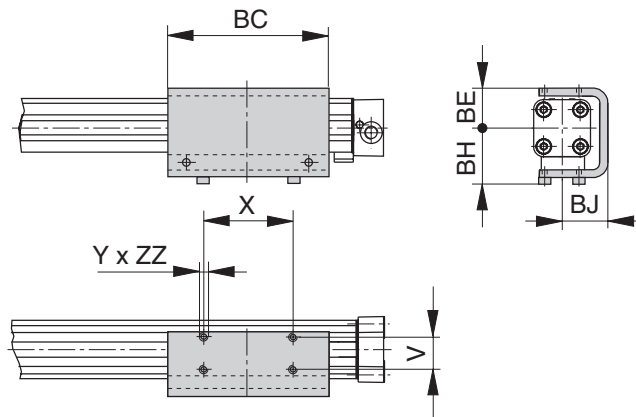

**Series OSP-P40 to 80**

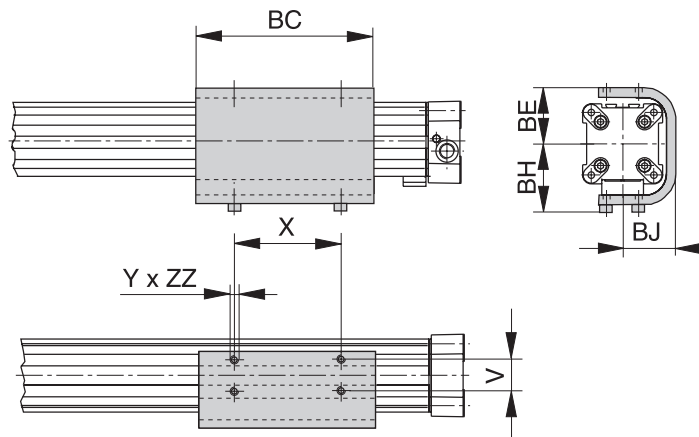

**Dimension (mm)**

Series	V	X	Y	BC	BE	BH	BJ	ZZ	Part Number
OSP-P16	16.5	36	M4	69	23	33	25	4	20446FIL
OSP-P25	25	65	M5	117	31	44	33.5	6	20037FIL
OSP-P32	27	90	M6	150	38	52	39.5	6	20161FIL
OSP-P40	27	90	M6	150	46	60	45	8	20039FIL
OSP-P50	27	110	M6	200	55	65	52	8	20166FIL
OSP-P63	34	140	M8	255	68	83.5	64	10	20459FIL
OSP-P80	36	190	M10	347	88	107.5	82	15	20490FIL

**G**  
 Rodless Pneumatic Cylinders  
 OSP-P Series  
 P1X Series  
 GDL Series



For inventory, lead times, and kit lookup, visit [www.pdnplu.com](http://www.pdnplu.com)

**End Cap Mounting  $\varnothing$  10 to 80mm**

**For Linear-drive**

- Series OSP-P



On the end-face of each end cap there are four threaded holes for mounting the actuator.

The hole layout is square, so that the mounting can be fitted to the bottom, top or either side, regardless of the position chosen for the air connection.

**Material:**

- Series OSP-P10 – P32: Galvanized steel.
- Series OSP-P40 – P80: Anodized aluminum.

The mountings are supplied in pairs.

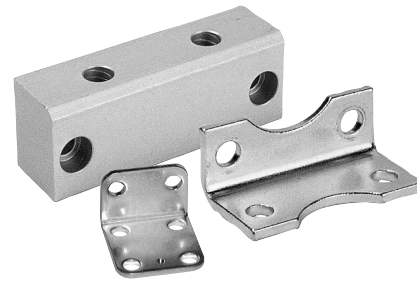

**Series OSP-P10: Type A1**

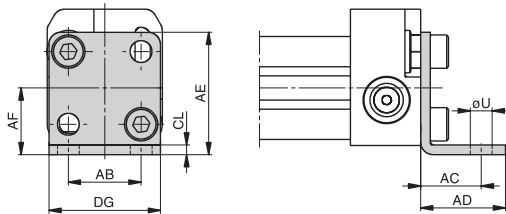

**Series OSP-P40 to 80: Type C1**

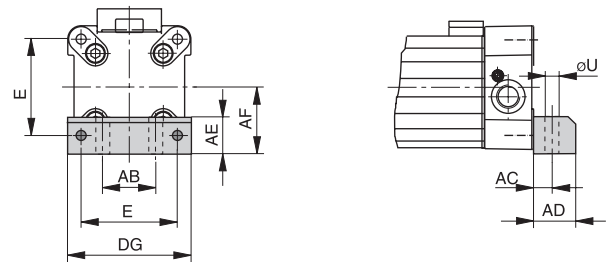

**Series OSP-P16 to 32: Type A1**

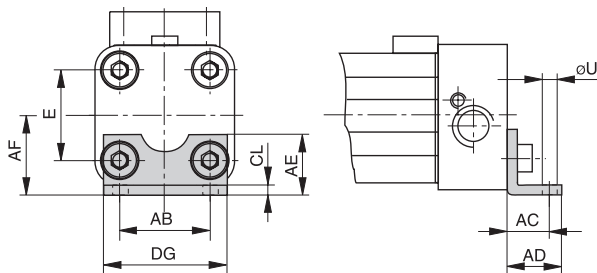

**Dimension (mm)**

Series	E	ØU	AB	AC	AD	AE	AF	CL	DG	Part Number (Pair)	
										Type A1	Type C1
OSP-P10	-	3.6	12	10	14	20.2	11	1.6	18.4	0240	-
OSP-P16	18	3.6	18	10	14	12.5	15	1.6	26	20408FIL	-
OSP-P25	27	5.8	27	16	22	18	22	2.5	39	2010	-
OSP-P32	36	6.6	36	18	26	20	30	3	50	3010	-
OSP-P40	54	9	30	12.5	24	24	38	-	68	-	4010FIL
OSP-P50	70	9	40	12.5	24	30	48	-	86	-	5010FIL
OSP-P63	78	11	48	15	30	40	57	-	104	-	6010FIL
OSP-P80	96	14	60	17.5	35	50	72	-	130	-	8010FIL



For inventory, lead times, and kit lookup, visit [www.pdnplu.com](http://www.pdnplu.com)



Rodless Pneumatic Cylinders

OSP-P Series

P1X Series

GDL Series

**Mid-Section Support ø 10 to 80mm**

For Linear-drive

- Series OSP-P

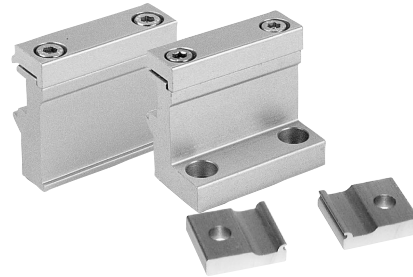

**Note on Types E1 and D1 (P16 – P80):**

The mid-section support can also be mounted on the underside of the actuator, in which case its distance from the center of the actuator is different.

Stainless steel version on demand.

**Series OSP-10, Type E1**

(Mounting from above / below using a cap screw)

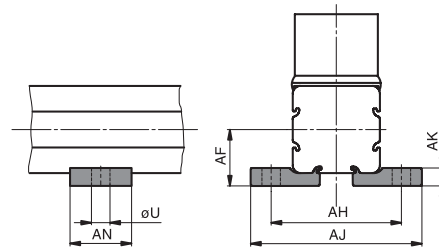

**Series OSP-P16 to P80: Type E1**

(Mounting from above / below using a cap screw)

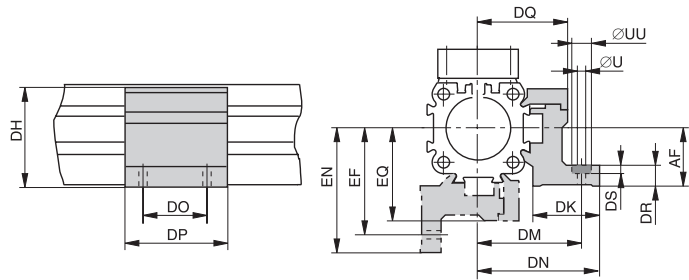

**Series OSP-16 to 80, Type D1**

(Mountings from below with 2 screws)

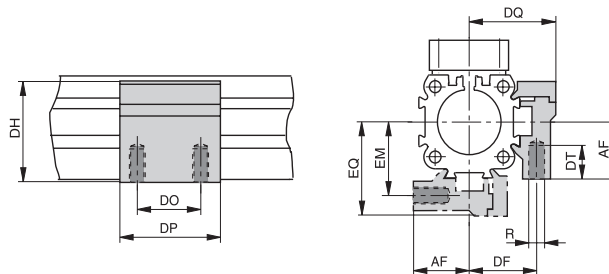

**Dimension (mm)**

Series	U	AF	AH	AJ	AK	AN	Part Number	
							Type E1	Type D1
OSP-P10	3.6	11	25.4	33.4	3.5	12	0250	-

Series	R	U	UU	AF	DF	DH	DK	DM	DN	DO	DP	DQ	DR	DS	DT	EF	EM	EN	EQ	Part Number	
																				Type E1	Type D1
OSP-P16	M3	3.4	6	15	20	29.2	24	32	36.4	18	30	27	6	3.4	6.5	32	20	36.4	27	20435FIL	20434FIL
OSP-P25	M5	5.5	10	22	27	38	26	40	47.5	36	50	34.5	8	5.7	10	41.5	28.5	49	36	20009FIL	20008FIL
OSP-P32	M5	5.5	10	30	33	46	27	46	54.5	36	50	40.5	10	5.7	10	48.5	35.5	57	43	20158FIL	20157FIL
OSP-P40	M6	7	-	38	35	61	34	53	60	45	60	45	10	-	11	56	38	63	48	20028FIL	20027FIL
OSP-P50	M6	7	-	48	40	71	34	59	67	45	60	52	10	-	11	64	45	72	57	20163FIL	20162FIL
OSP-P63	M8	9	-	57	47.5	91	44	73	83	45	65	63	12	-	16	79	53.5	89	69	20452FIL	20451FIL
OSP-P80	M10	11	-	72	60	111.5	63	97	112	55	80	81	15	-	25	103	66	118	87	20482FIL	20480FIL

**G**  
 Rodless Pneumatic Cylinders  
 OSP-P Series  
 P1X Series  
 GDL Series



For inventory, lead times, and kit lookup, visit [www.pdnplu.com](http://www.pdnplu.com)



**Adaptor Profile  $\varnothing$  16 to 50mm**

For Linear-drive

- Series OSP-P



**Adaptor Profile OSP**

- A universal attachment for mounting of valves etc.
- Solid material

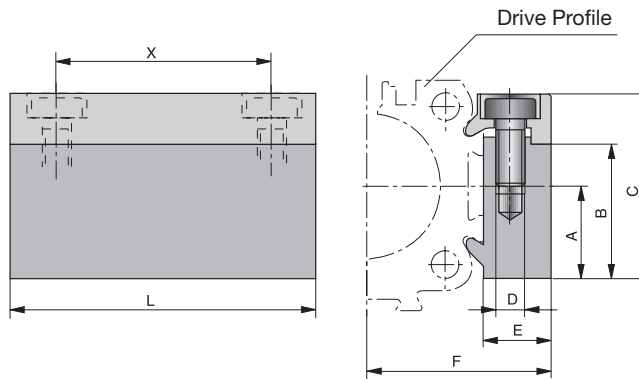
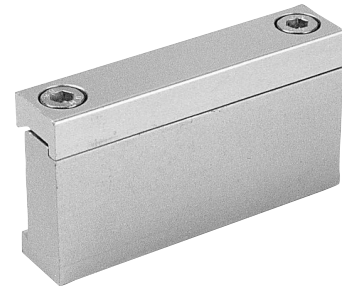

**Dimension (mm)**

Series	A	B	C	D	E	F	L	X	Part Number	
									Standard	Stainless
OSP-P16	14	20.5	28	M3	12	27	50	38	20432FIL	20438FIL
OSP-P25	16	23	32	M5	10.5	30.5	50	36	20006FIL	20186FIL
OSP-P32	16	23	32	M5	10.5	36.5	50	36	20006FIL	20186FIL
OSP-P40	20	33	43	M6	14	45	80	65	20025FIL	20267FIL
OSP-P50	20	33	43	M6	14	52	80	65	20025FIL	20267FIL



Rodless Pneumatic  
Cylinders

OSP-P  
Series

P1X  
Series

GDL  
Series



For inventory, lead times, and kit lookup, visit [www.pdnplu.com](http://www.pdnplu.com)

**T-Slot Profile  $\varnothing$  16 to 50mm**

For Linear-drive

- Series OSP-P

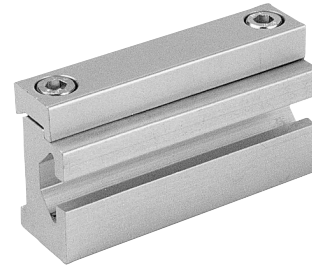

**T-Slot Profile OSP**

- A universal attachment for mounting with standard T-Nuts

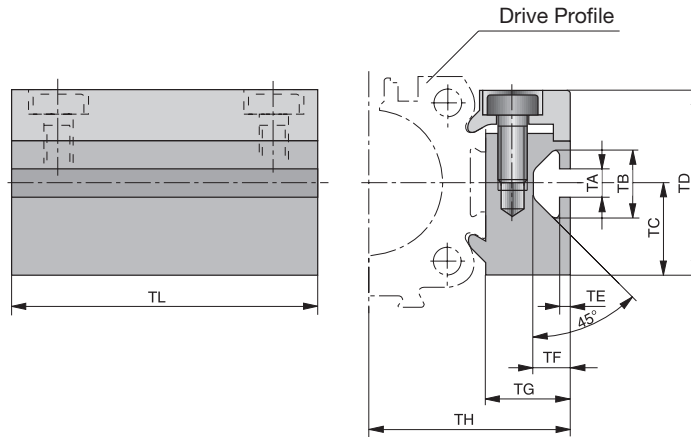

**Dimension (mm)**

Series	TA	TB	TC	TD	TE	TF	TG	TH	TL	Part Number
										Standard
OSP-P16	5	11.5	14	28	1.8	6.4	12	27	50	20433FIL
OSP-P25	5	11.5	16	32	1.8	6.4	14.5	34.5	50	20007FIL
OSP-P32	5	11.5	16	32	1.8	6.4	14.5	40.5	50	20007FIL
OSP-P40	8.2	20	20	43	4.5	12.3	20	51	80	20026FIL
OSP-P50	8.2	20	20	43	4.5	12.3	20	58	80	20026FIL

**G**  
 Rodless Pneumatic Cylinders  
 OSP-P Series  
 P1X Series  
 GDL Series



For inventory, lead times, and kit lookup, visit [www.pdnplu.com](http://www.pdnplu.com)

**Connection Profile  $\varnothing$  16 to 50mm**

**For combining**

- Series OSP-P with system profiles
- Series OSP-P with Series OSP-P

**OSP**

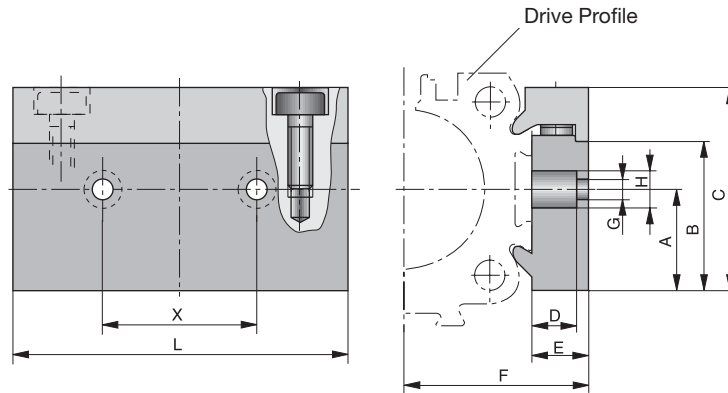

**Dimension (mm)**

Cylinder Series	For Mounting on the Carrier of	A	B	C	D	E	F	G	H	L	X	Part Number
OSP-P16	OSP25	14	20.5	28	8.5	12	27	5.5	10	50	25	20849FIL
OSP-P25	OSP32-50	16	23	32	8.5	10.5	30.5	6.6	11	60	27	20850FIL
OSP-P32	OSP32-50	16	23	32	8.5	10.5	36.5	6.6	11	60	27	20850FIL
OSP-P40	OSP32-50	20	33	43	8	14	45	6.6	11	60	27	20851FIL
OSP-P50	OSP32-50	20	33	43	8	14	52	6.6	11	60	27	20851FIL

**Possible Combinations**

**Combination of Series OSP-P with system profiles**

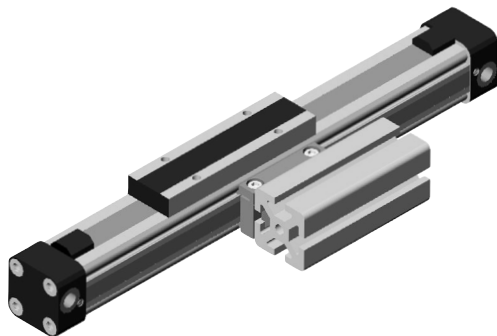

**Combination of Series OSP-P with Series OSP-P**

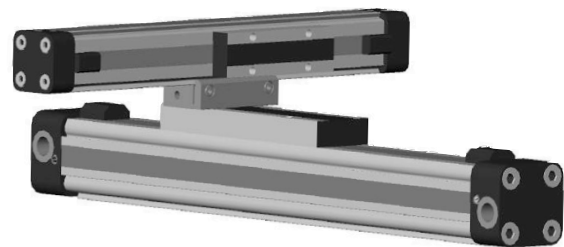

**G**

Rodless Pneumatic Cylinders

OSP-P Series

P1X Series

GDL Series



**Features**

**Clean Room Cylinder ø 16 – 32 mm Rodless Cylinder certified to DIN EN ISO 14644-1**

**Standard Features:**

- Double-acting with adjustable end cushioning
- With magnetic piston for position sensing
- Clean Room classification  
ISO Class 4 at  $v_m = 0.14$  m/s  
ISO Class 5 at  $v_m = 0.5$  m/s
- Suitable for smooth slow speed operation up to  $v_{min} = 0.005$  m/s
- Optional stroke length up to 1200mm (longer strokes on request)
- Low maintenance
- Compact design with equal force and velocity in both directions
- Aluminum piston with bearing rings to support high direct and cantilever loads
- Stainless steel screws

**Optional Features:**

- Slow speed lubrication
- Fluorocarbon (FKM) seals

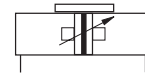

**OSP**

**Operating information**

Operating pressure:	116 PSIG (8 bar)
Temperature range:	14°F to 176°F (10°C to 80°C)
Filtration requirements:	Filtered, nonlubricated compressed air

**Specifications**

- Type Rodless cylinder
- Series OSP-P
- Stroke length 5.5m (216 inches)
- System Double-acting, with cushioning, position sensing capability
- Mounting See drawings
- Air connection Threaded
- Weight (mass) See table
- Installation In any position
- Lubrication Prelubricated at the factory (additional oil mist lubrication not required)
- Option: special slow speed grease

**Material specifications**

Cylinder profile	Anodized aluminum
Carrier (piston)	Anodized aluminum
End caps	Aluminum, lacquered
Sealing bands	Corrosion resistant steel
Seals	NBR (Option: Fluorocarbon)
Screws	Stainless steel
Covers	Anodized aluminum
Guide plate	Plastic

**Weight (mass) kg**

Cylinder series (Basic cylinder)	Weight (Mass) kg	
	at 0mm stroke	per 100mm stroke
OSP-P16	0.22	0.1
OSP-P25	0.65	0.197

**Size Comparison**

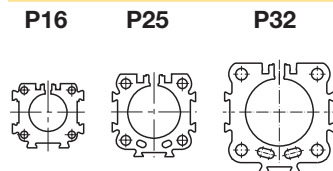

**G**  
 Rodless Pneumatic Cylinders  
 OSP-P Series  
 P1X Series  
 GDL Series



For inventory, lead times, and kit lookup, visit [www.pdnplu.com](http://www.pdnplu.com)

Ordering information for OSP-P rodless Clean Room pneumatic series

1-4	5-6	7	8	9	10	11	12-16	17	18	19	20	21	22	23	24	25																
<b>OSP</b> <b>P</b>																<b>32</b>	<b>0</b>	<b>1</b>	<b>0</b>	<b>0</b>	<b>0</b>	<b>01100</b>	<b>0</b>	<b>0</b>	<b>0</b>	<b>0</b>	<b>0</b>	<b>0</b>	<b>0</b>	<b>1</b>	<b>0</b>	<b>0</b>
																<b>Bore</b> 16 25 32	<b>Lubrication</b> 5 Clean Room		<b>Stroke</b> x x x x x 5 digits in whole millimeters (ex. 1100mm = 01100)		<b>Cushions / Stops</b> 0 Standard		<b>Piston Mounting</b> 0 None		<b>Dovetail Cover</b> 0 Standard X Without Cover Rail		<b>Version</b> 0 Standard					
																<b>Seals</b> 0 Buna-N 1 Fluorocarbon		<b>Hardware</b> 0 Standard 1 Stainless Steel		<b>Additional Carriages</b> 0 None		<b>Endcap Mounting</b> 0 None 1 A1 (16,25,32) 2 A2 (16,25,32) 3 A3 (25,32) 4 B1 (25,32) 6 B3 (16) 7 B4 (25,32) 8 B5 (32)										
																<b>Piston Style</b> 0 Standard		<b>Porting Configurations</b> 7 Clean Room		<b>Endcap Position</b> 0 Both Pos #2		<b>Guides / brakes</b> 0 None		<b>Switches</b> ◊ 0 None 1 Normally Open Reed Switch 2 Normally Closed Reed Switch 3 PNP Hall Sensor w/Extension Cables 4 NPN Hall Sensor w/Extension Cables								
																<b>Notes:</b> Comes in pairs																
																<b>Sensors</b> See section L for sensors. 																

**G**  
Rodless Pneumatic Cylinders

OSP-P Series

P1X Series

GDL Series



**Certification**

Based on the Parker's rodless cylinder, proven in world wide markets, Parker now offers the only rodless cylinder on the market with a certification from IPA Institute for the clean room specification according to DIN EN ISO 14644-1.

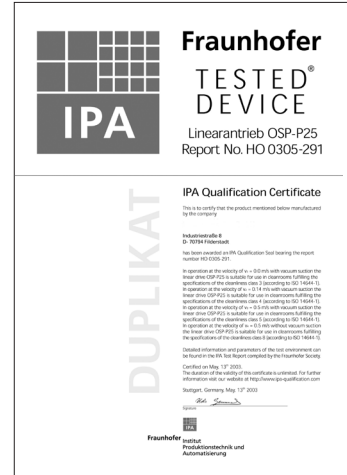

**Function**

The clean room cylinders of the OSP-P combines the efficiency of the slot seal system with vacuum protection against progressive wear and contamination from the sliding components. A partial vacuum drawn between inner and outer sealing bands prevents emission into the clean room. To achieve the necessary vacuum a suction flow of ca. 4 m³/h is required.

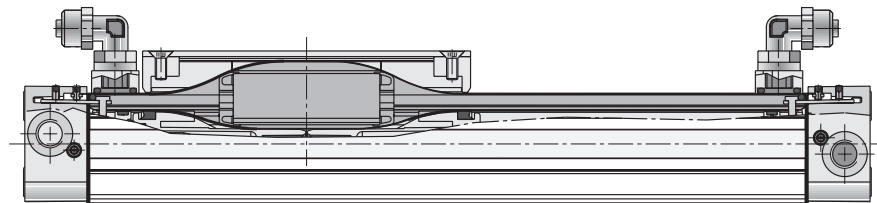

**Loads, Forces and Moments**

Cylinder Series (mm Ø)	Effective Force at 6 bar (N)	Max. Moment			Max. Load Fz (N)	Cushion length (mm)
		Mx (Nm)	My (Nm)	Mz (Nm)		
OSP-P16	78	0.45	4	0.5	120	11
OSP-P25	250	1.5	15	3.0	300	17
OSP-P32	420	3.0	30	5.0	450	20

Load and moment data are based on speeds  $v \leq 0.2$  m/s. The adjacent table shows the maximum values for light, shock-free operation which must not be exceeded even in dynamic operation.

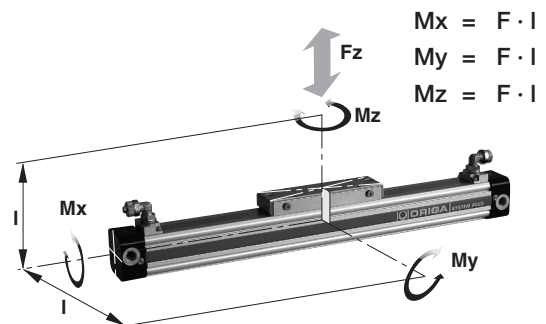

**G**  
 Rodless Pneumatic Cylinders  
 OSP-P Series  
 P1X Series  
 GDL Series



For inventory, lead times, and kit lookup, visit [www.pdnplu.com](http://www.pdnplu.com)

**Clean Room Cylinders  $\varnothing$  16-32 mm**

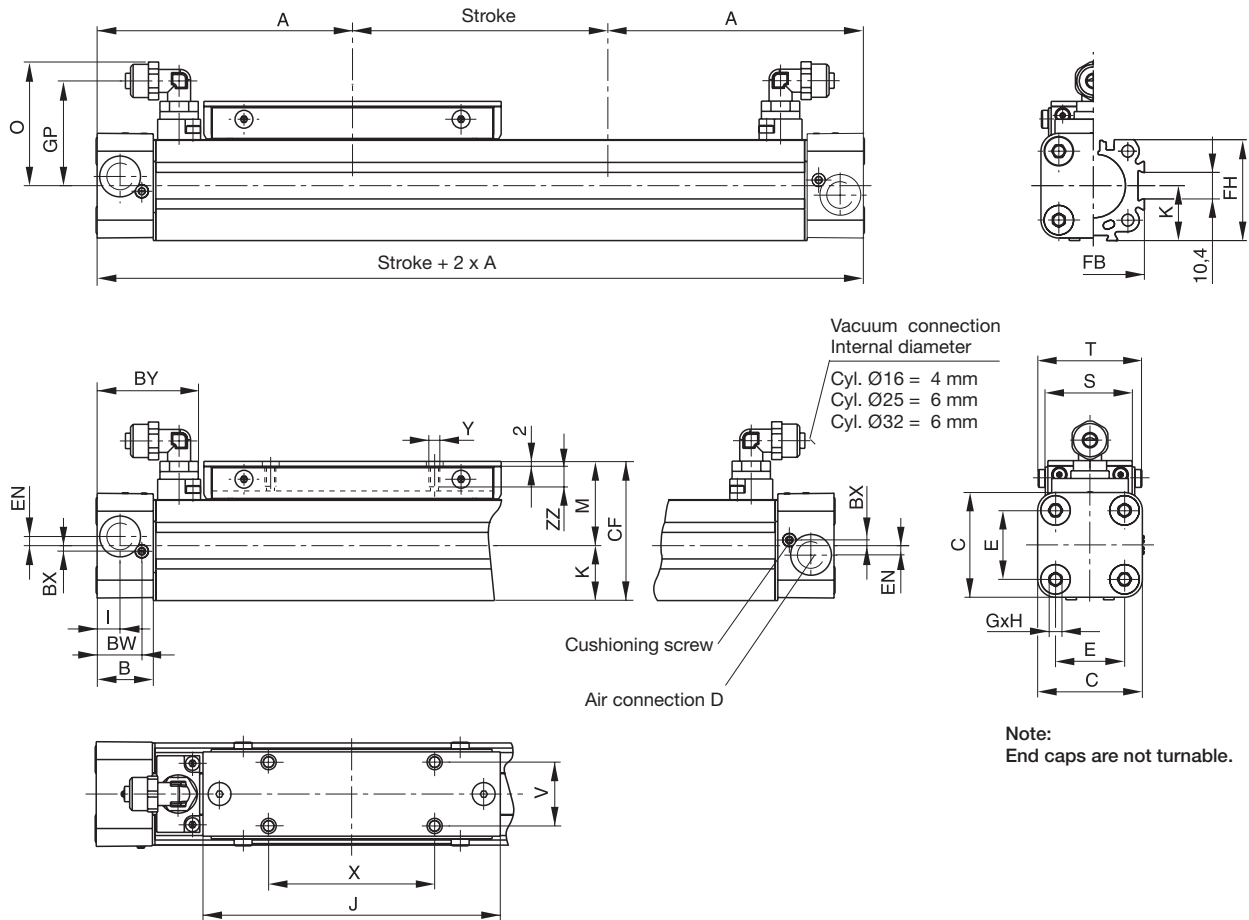

Note:  
 End caps are not turnable.

**Dimension (mm)**

Series	A	B	C	D	E	G	H	I	J	K	M	O	S
OSP-P16	65	14	30	M5	18	M3	9	5.5	69	15	25	31	24
OSP-P25	100	22	41	G1/8	27	M5	15	9	117	21.5	33	48.5	35
OSP-P32	125	25.5	52	G1/4	36	M6	15	11.5	152	28.5	40	53.6	38

Series	T	V	X	Y	BW	BX	BY	CF	EN	FB	FH	GP	ZZ
OSP-P16	29.6	16.5	36	M4	10.8	1.8	28.5	40	3	30	27.2	25.7	7
OSP-P25	40.6	25	65	M5	17.5	2.2	40.5	54.5	3.6	40	39.5	41	8
OSP-P32	45	27	90	M6	20.5	2.5	47.1	68.5	5.5	52	51.7	46.2	10



Rodless Pneumatic Cylinders

OSP-P Series

P1X Series

GDL Series



For inventory, lead times, and kit lookup, visit [www.pdnplu.com](http://www.pdnplu.com)

G37

**Parker Hannifin Corporation**  
 Pneumatic Division  
 Wadsworth, Ohio  
[www.parker.com/pneumatics](http://www.parker.com/pneumatics)

**Features**

**Synchronized Bi-Parting movements Type OSP-P40-SL-BP for Rodless Cylinder ø 40mm**

**Standard Features:**

- Accurate bi-parting movement through toothed belt synchronization
- Optimum slow speed performance
- Increased action force
- Anodized aluminum guide rail with prism-form slideway arrangement
- Adjustable polymer slide units
- Combined sealing system with polymer and felt elements to remove dirt and lubricate the slideway
- Integrated grease nipples for guide lubrication

**Applications:**

- Opening and closing operations
- Gripping of workpieces – outside
- Gripping of hollow workpieces – inside
- Gripping underneath larger objects
- Clamping force adjustable via pressure regulator

**Specifications**

- Type Rodless cylinder for synchronized bi-parting movements
- Series OSP-P
- System Double-acting, with end cushioning, for contactless position sensing
- Guide Slideline SL40
- Synchronization Toothed belt
- Mounting See drawing
- Weight (mass) See table
- Lubrication Special slow speed grease (additional oil mist lubrication not required)
- Cushioning middle position Elastic buffer
- Maximum speed 0.2 m/s  $V_{max}$
- Maximum stroke of each stroke 500 mm
- Maximum mass per guide carrier
  - lateral moment 25 Nm  $M_{x_{max}}$
  - axial moment 46 Nm  $M_{y_{max}}$
  - rotating moment 46 Nm  $M_{z_{max}}$
- Option: special slow speed grease

**Size**

P40

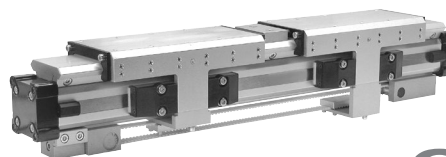
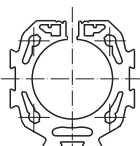

**OSP**

**Operating information**

Operating pressure:	116 PSIG (8 bar)
Temperature range:	14°F to 140°F (-10°C to 60°C)
Filtration requirements:	Filtered, nonlubricated compressed air

**Material specifications**

Belt wheel	Aluminum
Toothed belt	Steel-corded polyurethane

**Weight (mass) kg**

Cylinder Series (Basic cylinder)	Weight (Mass) kg	
	at 0mm Stroke	per 100mm Stroke
OSP-P40-SL-BP	10.334	2.134

**Applications**

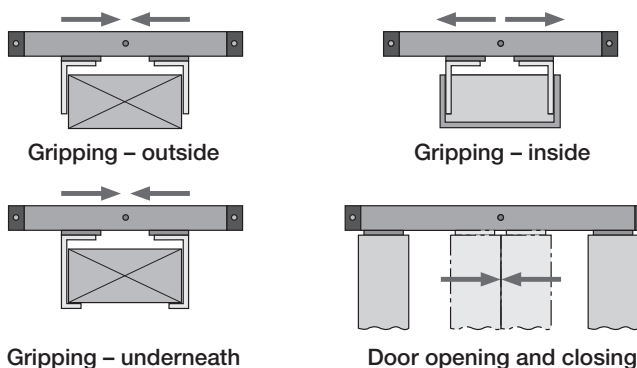

**G**  
 Rodless Pneumatic Cylinders  
 OSP-P Series  
 P1X Series  
 GDL Series



For inventory, lead times, and kit lookup, visit [www.pdnplu.com](http://www.pdnplu.com)



**Ordering information for OSP-P rodless Bi-Parting pneumatic series**

1-4	5-6	7	8	9	10	11	12-16	17	18	19	20	21	22	23	24	25
<b>OSP</b>	<b>P</b>	<b>40</b>	<b>0</b>	<b>1</b>	<b>0</b>	<b>0</b>	<b>01100</b>	<b>0</b>	<b>0</b>	<b>0</b>	<b>0</b>	<b>0</b>	<b>0</b>	<b>1</b>	<b>0</b>	<b>0</b>

<b>Bore</b>	40
<b>Piston Style</b>	N Bi-Parting
<b>Lubrication</b>	0 Standard
<b>Stroke†</b>	xxxxx 5 digits in whole millimeters (ex. 1100mm = 01100)
<b>Cushions / Stops</b>	0 Standard
<b>Piston Mounting</b>	0 None
<b>Hardware</b>	0 Standard 1 Stainless Steel
<b>Porting Configurations</b>	0 Standard 1 End face 3 Left Std Pos #2, Right Pos #5 4 Left Pos #5, Right Std Pos #2 6 Single End Porting at #5
<b>Seals</b>	0 Standard
<b>Additional Carriages</b>	0 None
<b>Guides / Brakes</b>	0 None
<b>Dovetail Cover</b>	0 Standard X Without Cover Rail
<b>Version</b>	0 Standard
<b>Endcap Position</b>	0 Both Pos #2 1 Both Pos #3 2 Both Pos #4 3 Both Pos #1 4 Left #3 / Right #2 5 Left #4 / Right #2 6 Left #1 / Right #2 7 Left #2 / Right #3 8 Left #4 / Right #3 9 Left #1 / Right #3 A Left #2 / Right #4 B Left #3 / Right #4 C Left #1 / Right #4 D Left #2 / Right #1 E Left #3 / Right #1 F Left #4 / Right #1
<b>Endcap Mounting</b>	0 None A C2 B C3 C C4 <small>Note: Comes in pairs</small>
<b>Switches ◊</b>	0 None 1 Normally Open Reed Switch 2 Normally Closed Reed Switch 3 PNP Hall Sensor w/Extension Cables 4 NPN Hall Sensor w/Extension Cables <small>◊ Note: 2 switches will be supplied. For different quantity, please order as a separate line item.</small>

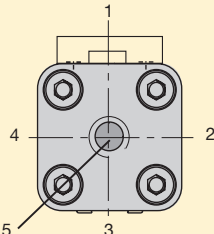

**Note: Position #2 is the standard location.**

† Reference Cylinder Stroke and Dead Length A, pages G16-G17 for stroke consideration because of the use of two pistons.

**Sensors**

See section L for sensors.



**Function:**

The OSP-P40-SL-BP bidirectional linear drive is based on the OSP-P40 rodless pneumatic cylinder and adapted SLIDELINE SL40 polymer plain-bearing guides.

Two pistons in the cylinder bore are connected via yokes and carriers to the SLIDELINE guide carriers, which handle the forces and moments generated.

The bi-parting movements of the guide carriers are accurately synchronized by a recirculating toothed belt.

The two pistons are driven from the middle to the end positions via a common G1/4 air connection in the middle of the cylinder, and are driven from the end positions to the middle via an air connection in each end cap.

End position cushioning is provided by adjustable air cushioning in the end caps, and middle position cushioning by rubber buffers.

**Dimensions (mm)**

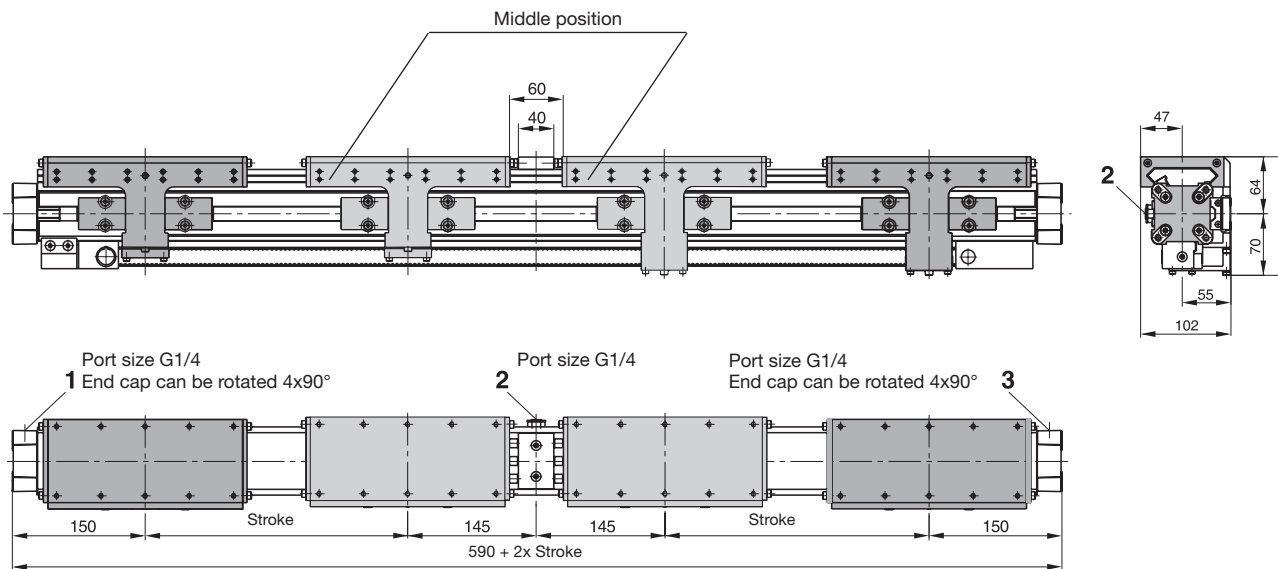

**Air connections:**

To drive the guide carriers to the middle position: pressurize ports 1 and 3.

To drive the guide carriers to the end positions: pressurize port 2.

For more dimensions see pages G18 and G19.

**G**  
 Rodless Pneumatic  
 Cylinders  
 OSP-P  
 Series  
 P1X  
 Series  
 GDL  
 Series



For inventory, lead times, and kit lookup, visit [www.pdnplu.com](http://www.pdnplu.com)

G40

**Parker Hannifin Corporation**  
 Pneumatic Division  
 Wadsworth, Ohio  
[www.parker.com/pneumatics](http://www.parker.com/pneumatics)

Linear Guides for OSP-P Series

# OSP

**Adaptive modular system**

The OSP Series provides a comprehensive range of linear guides for the pneumatic OSP-P.

**Advantages:**

- Takes high loads and forces
- High precision
- Smooth operation
- Can be retrofitted
- Can be installed in any position

**Series OSP-P - Standard**

- Piston diameters 10 to 80mm



**SLIDELINE**

- The cost-effective plain bearing guide for medium loads.
- Active/ Passive Brake optional.
- Piston diameters 16 to 80mm



**POWERSLIDE**

- The roller guide for heavy loads and hard application conditions
- Piston diameters 16 to 50mm

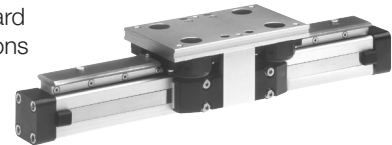

**PROLINE**

- The compact aluminum roller guide for high loads and velocities.
- Active / Passive Brake optional.
- Piston diameters 16 to 50mm



**STARLINE**

- Recirculating ball bearing guide for very high loads and precision
- Piston diameters 16 to 50mm



**KF GUIDE**

- Recirculating ball bearing guide for highest loads and precision.
- Correspond to FESTO dimensions (Type DGPL-KF)
- Piston diameters 16 to 50mm



**HD HEAVY DUTY GUIDE**

- The ball bushing guide for the heavy loads and greatest accuracy.
- Piston diameters 25 to 50mm

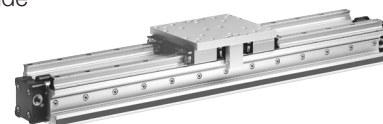

G

Rodless Pneumatic Cylinders

OSP-P Series

P1X Series

GDL Series



For inventory, lead times, and kit lookup, visit [www.pdnplu.com](http://www.pdnplu.com)

**Application Example - Vertical Application**

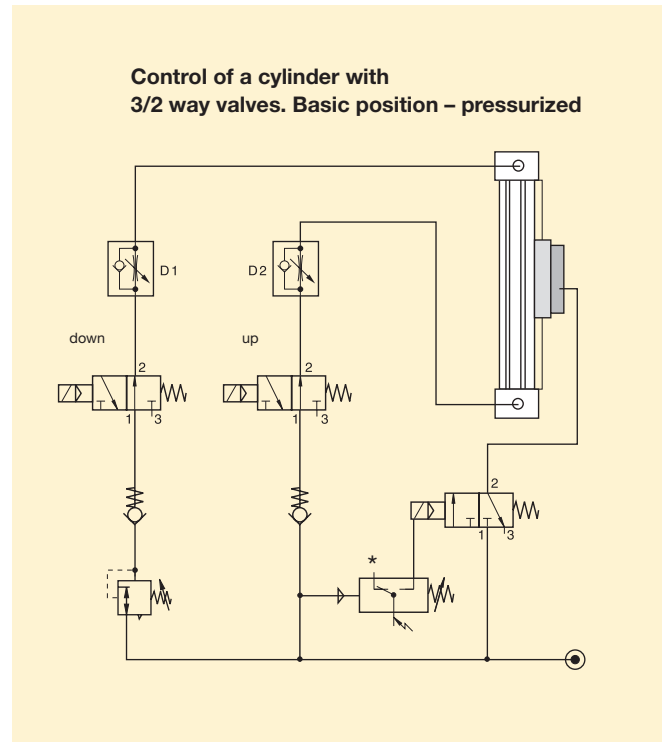
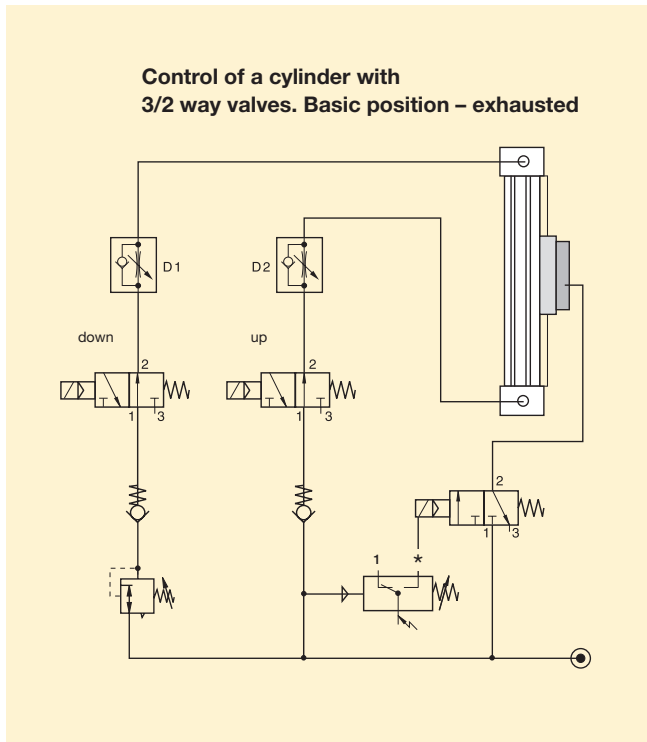

**G**  
 Rodless Pneumatic  
 Cylinders  
 OSP-P  
 Series  
 P1X  
 Series  
 GD  
 L  
 Series

**Control Examples**

Under normal operating circumstances the pressure switch is closed and the air flows through the 3/2 way solenoid valves from port 1 to 2, thus lifting the brake from the rail (operating condition).

The brake is pressurized by means of a 3/2 way valve in combination with a pressure switch. When there is a pressure loss, the brake is actuated by the pressure switch.

When the air pressure is restored to both cylinder chambers, the brake is lifted and the linear drive can be moved again.

The speed regulating valves D1 and D2 control the speed of the linear drive, and have no influence on the brake. The two non-return valves give the system a higher stability.

The pressure regulating valve is used to compensate for the downward force in this vertical application.

**Please note:**



**Before the brake is lifted, make sure that both air chambers of the linear drive are pressurized.**

**Small diameter tubing, fittings and valves with a nominal diameter, and tubing that is too long all change the reaction time of the brake!**

**\*Tip:**

The pressure switch actuates the brake when the pressure drops below the set value.

For accessories, such as tubing and fittings, please refer to our separate catalog.

**Required Components**

- Three, Three-Way Valves
- Port size  
M5, G1/8, G1/4, G1/2
- Pressure Regulator  
G1/8 - G3/8
- Pneumatic Accessories
- P/E-Switch
- Check Valves  
G1/8 - G3/8
- Flow Control Valves  
M5 - G1/4

Contact factory for literature on the above valves/accessories



Features

SLIDELINE, Plain Bearing Guide SL  $\varnothing$  16 to 80mm bore

For Linear-drive

- Series OSP-P

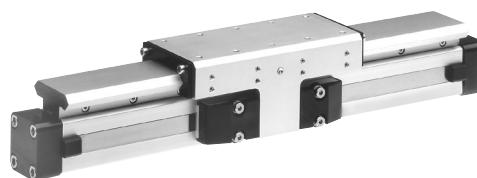

Features

- Maximum speed < 1 m/s
- Adjustable plastic slide elements – optional with integral brake
- Composite sealing system with plastic and felt wiper elements to remove dirt and lubricate the slideways
- Corrosion resistant version available on request
- Any length of stroke up to 5500mm (longer strokes on request)

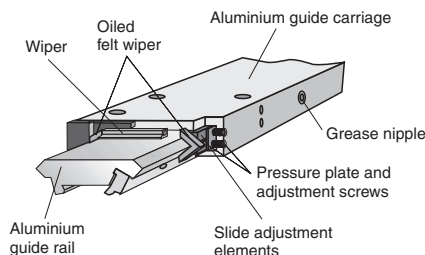

Integrated Brake (optional) for series OSP-P25 to OSP-P50:

- Actuated by pressure
- Released by exhausting and spring return

For further technical data see also linear drives OSP-P, see page G14.

Option – Integrated Brake

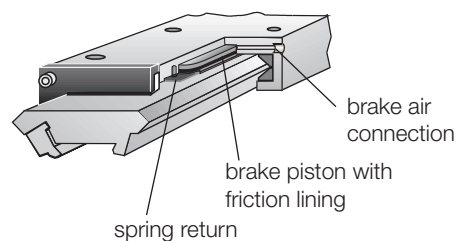

Loads, Forces and Moments

The table shows the maximum permissible values for smooth operation, which should not be exceeded even under dynamic conditions.

The load and moment figures apply to speeds  $v < 0.2$  m/s.

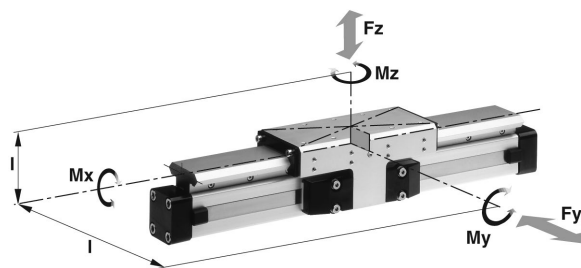

Series	For Linear Drive	Max. Moments (Nm)			Max. Loads (N) Fy, Fz	Maximum Braking Force a 6 Bar (N)†	Mass of Linear Drive with Guide (kg)		
		Mx	My	Mz			With 0mm Stroke	Increase per 100mm Stroke	Mass * of Guide Carriage (kg)
SL16	OSP-P16	6	11	11	325	–	0.57	0.22	0.23
SL25	OSP-P25	14	34	34	675	325	1.55	0.39	0.61
SL32	OSP-P32	29	60	60	925	545	2.98	0.65	0.95
SL40	OSP-P40	50	110	110	1500	835	4.05	0.78	1.22
SL50	OSP-P50	77	180	180	2000	1200	6.72	0.97	2.06
SL63	OSP-P63	120	260	260	2500	–	11.66	1.47	3.32
SL80	OSP-P80	120	260	260	2500	–	15.71	1.81	3.32

\* Add the mass of the guide carriage to the mass to be cushioned.

† Only with integrated brake: Braking force on dry oil-free surface values are decreased for lubricated slideways.

**G**  
 Rodless Pneumatic Cylinders  
 OSP-P Series  
 P1X Series  
 GDL Series



For inventory, lead times, and kit lookup, visit [www.pdnplu.com](http://www.pdnplu.com)

Ordering information for OSP-P rodless SLIDELINE pneumatic series

1-4	5-6	7	8	9	10	11	12-16	17	18	19	20	21	22	23	24	25
<b>OSP</b>	<b>PP</b>	<b>25</b>	<b>0</b>	<b>1</b>	<b>0</b>	<b>0</b>	<b>0</b>	<b>0</b>	<b>0</b>	<b>0</b>	<b>0</b>	<b>0</b>	<b>0</b>	<b>1</b>	<b>0</b>	<b>0</b>
		<b>Bore</b>				<b>Lubrication</b>	<b>Stroke</b>	<b>Cushioning &amp; Stops</b>					<b>Dovetail Cover</b>	<b>Version</b>		
		16 25 32 40 50 63 80				0 Standard 1 Slow Speed	xxxxx 5 digits in whole millimeters (ex. 1100mm = 01100)	0 Standard 1 Long Cushions (25,32,40)					0 Standard	0 Standard		
						<b>Seals</b>				<b>Piston Mounting</b>						
						0 Standard 1 Fluorocarbon				0 None						
						<b>Hardware</b>				<b>Guides / Brakes</b>						
						0 Standard 1 Stainless Steel				2 Slideline Guide						
						<b>Porting Configurations†</b>				<b>Endcap Position</b>						
						0 Standard 1 End Face (16,25,32,40,50,63,80) 2 Single End Porting (25,32,40,50,63,80) 3 Left Std Pos #2, Right Pos #5 (16,25,32,40,50,63,80) 4 Left Pos #5, Right Std Pos #2 (16,25,32,40,50,63,80) 6 Single End Porting at #5 (50,63,80) A 24VDC VOE Valves (25,32,40,50) B 220VAC VOE Valves (25,32,40,50) C 48VDC VOE Valves (25,32,40,50) E 110VAC VOE Valves (25,32,40,50)				0 Both Pos #2 1 Both Pos #3 2 Both Pos #4 3 Both Pos #1 4 Left #3 / Right #2 5 Left #4 / Right #2 6 Left #1 / Right #2 7 Left #2 / Right #3 8 Left #4 / Right #3 9 Left #1 / Right #3 A Left #2 / Right #4 B Left #3 / Right #4 C Left #1 / Right #4 D Left #2 / Right #1 E Left #3 / Right #1 F Left #4 / Right #1						
										<b>Additional Carriages**</b>						
										0 None 2 Slideline Guide M Guide Carriage without Brake Function						
												<b>Endcap Mounting</b>				
												0 None 1 A1 (16,25,32) 2 A2 (16,25,32) 3 A3 (25,32) 4 B1 (25,32) 6 B3 (16) 7 B4 (25,32) 8 B5 (32) 9 C1 (40,50,63,80) A C2 (40,50,63,80) B C3 (40,50,63,80) C C4 (40,50,63,80)				
												Note: Comes in pairs				
												<b>Switches †</b>				
												0 None 1 Normally Open Reed Switch (16 thru 80) 2 Normally Closed Reed Switch (16 thru 80) 3 PNP Hall Sensor w/Extension Cables (16 thru 80) 4 NPN Hall Sensor w/Extension Cables (16 thru 80) X SFI 0.1mm RES (25 thru 80) Y SFI 1mm RES (25 thru 80)				
												† Note: 2 switches will be supplied. For different quantity, please order as a separate line item.				

Note: Single end porting on 16mm bore, then end caps cannot be rotated.

\*\*Note: Available on tandem piston only

† Note: 2 switches will be supplied. For different quantity, please order as a separate line item.

G Rodless Pneumatic Cylinders

OSP-P Series

P1X Series

GDL Series

**Cylinder with guide end cap positioning**

**Sensors**

See section L for sensors.

**SLIDELINE  $\varnothing$  16 to 80mm**

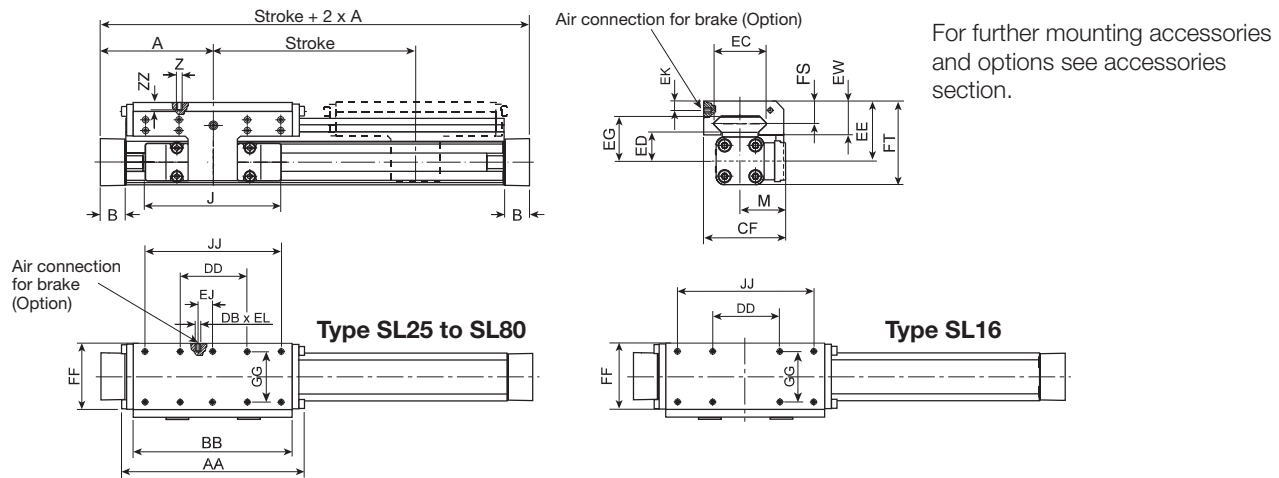

**Dimensions (mm)**

Series	A	B	J	M	Z	AA	BB	DB	DD	CF	EC	ED	EE	EG	EJ	EK	EL	EW	FF	FT	FS	GG	JJ	ZZ
SL16	65	14	69	31	M4	106	88	-	30	55	36	8	40	30	-	-	-	22	48	55	14	36	70	8
SL25	100	22	117	40.5	M6	162	142	M5	60	72.5	47	12	53	39	22	6	6	30	64	73.5	20	50	120	12
SL32	125	25.5	152	49	M6	205	185	M5	80	91	67	14	62	48	32	6	6	33	84	88	21	64	160	12
SL40	150	28	152	55	M6	240	220	M5	100	102	77	14	64	50	58	6	6	34	94	98.5	21.5	78	200	12
SL50	175	33	200	62	M6	284	264	M5	120	117	94	14	75	56	81	6	6	39	110	118.5	26	90	240	16
SL63	215	38	256	79	M8	312	292	-	130	152	116	18	86	66	-	-	-	46	152	139	29	120	260	14
SL80	260	47	348	96	M8	312	292	-	130	169	116	18	99	79	-	-	-	46	152	165	29	120	260	14

**Mid-Section Support**

(for versions see pages G80 to G83)

Mid-section supports are required from a certain stroke length to prevent excessive deflection and vibration of the linear drive. The diagrams show the maximum permissible unsupported length in relation to loading. A distinction must be drawn between loading 1 and loading 2.

Deflection of 0.5 mm max. between supports is permissible.

**Note:** For speeds  $v > 0.5$  m/s the distance between supports should not exceed 1 m.

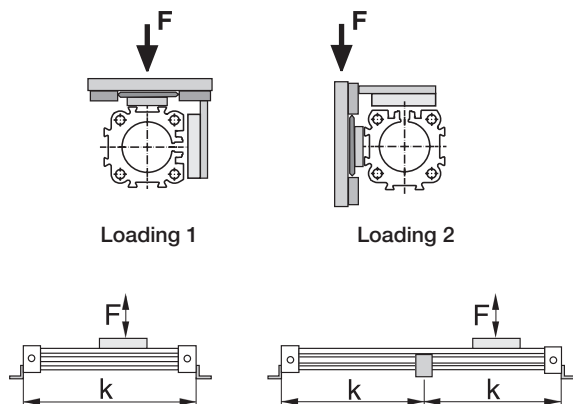

**SLIDELINE 16 to 32mm bore**

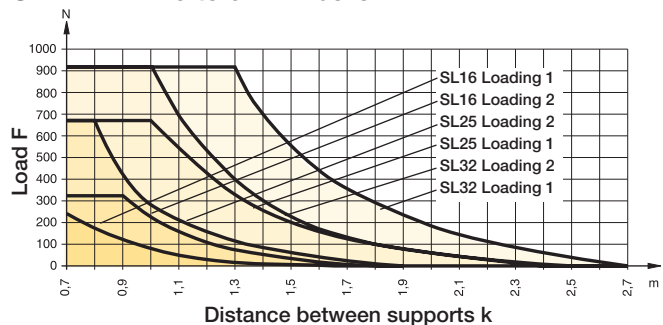

**SLIDELINE 40 to 80mm bore**

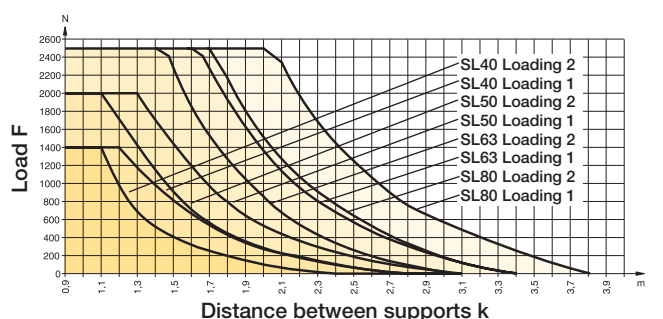

For inventory, lead times, and kit lookup, visit [www.pdnplu.com](http://www.pdnplu.com)



**Multi-Brake Passive Brakes MB-SL ø 25 to 80mm bore**

**Series MB-SL 25 to 80 for Linear-drive**



- Series OSP-P

**Features**

- Brake operated by spring actuation
- Brake release by pressurization
- Anodized aluminum rail, with prism shaped slide elements
- Adjustable plastic slide elements
- Composite sealing system with plastic and felt wiper elements to remove dirt and lubricate the slideway
- Replenishable guide lubrication by integrated grease nipples
- Blocking function in case of pressure loss
- Intermediate stops possible

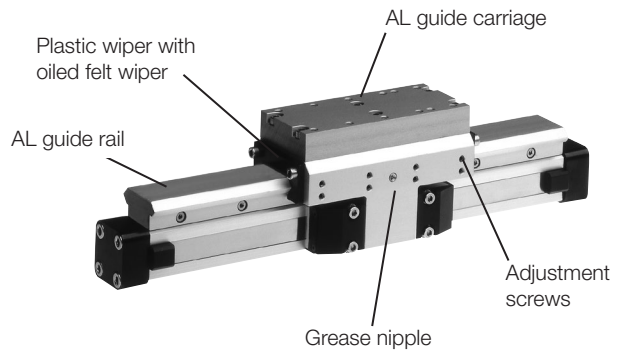

**Function**

The Multi-Brake is a passive device. When the air pressure is removed the brake is actuated and movement of the cylinder is blocked. The brake is released by pressurization.

The high friction, wear resistant brake linings allow the Multi-Brake to be used as a dynamic brake to stop cylinder movement in the shortest possible time. The powerful springs also allow the Multi-Brake to be used effectively in positioning applications.

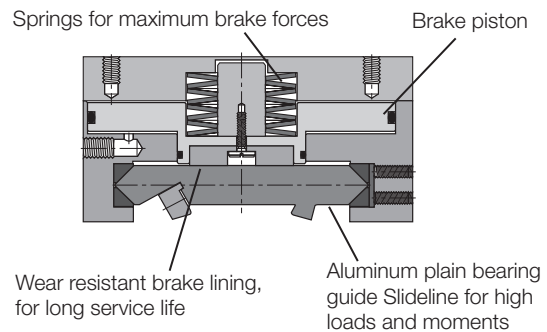

**Loads, Forces and Moments**

The table shows the maximum values for light, shock-free operation, which must not be exceeded even in dynamic operation.

Load and moment data are based on speeds  $v < 0.2$  m/s.

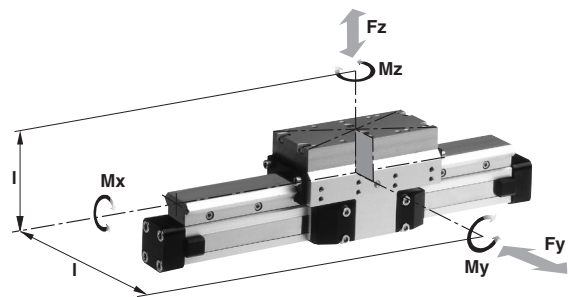

Series	For Linear Drive	Max. Moments (Nm)			Max. Loads (N)		Maximum Braking Force a 6 Bar (N) †	Mass of Linear Drive with Guide (kg)		
		Mx	My	Mz	Fy, Fz	With 0mm Stroke		Increase per 100mm Stroke	Mass * Guide Carriage (kg)	
MB-SL25	OSP-P25	14	34	34	675	470	2.04	0.39	1.10	
MB-SL32	OSP-P32	29	60	60	925	790	3.82	0.65	1.79	
MB-SL40	OSP-P40	50	110	110	1500	1200	5.16	0.78	2.34	
MB-SL50	OSP-P50	77	180	180	2000	1870	8.29	0.97	3.63	
MB-SL63	OSP-P63	120	260	260	2500	2900	13.31	1.47	4.97	
MB-SL80	OSP-P80	120	260	260	2500	2900	17.36	1.81	4.97	

\* Add the mass of the guide carriage to the mass to be cushioned.

† Braking surface dry – oil on the braking surface will reduce the raking force.

**G**  
 Rodless Pneumatic Cylinders  
 OSP-P Series  
 P1X Series  
 GDL Series



For inventory, lead times, and kit lookup, visit [www.pdnplu.com](http://www.pdnplu.com)



**OSP-P with Passive Brake MB-SL**

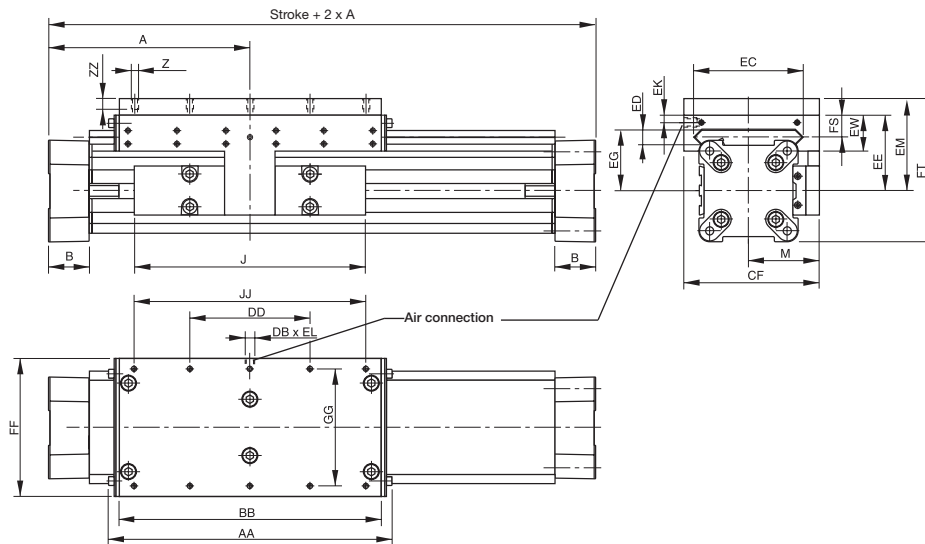

**Dimension (mm)**

Series	A	B	J	M	Z	AA	BB	DB	DD	CF	EC	ED	EE	EG	EK	EL	EM	EW	FF	FT	FS	GG	JJ	ZZ
MB-SL25	100	22	117	40,5	M6	162	142	M5	60	72.5	47	12	53	39	9	5	73	30	64	93.5	20	50	120	12
MB-SL32	125	25.5	152	49	M6	205	185	G1/8	80	91	67	14	62	48	7	10	82	33	84	108	21	64	160	12
MB-SL40	150	28	152	55	M6	240	220	G1/8	100	102	77	14	64	50	6.5	10	84	34	94	118.5	21.5	78	200	12
MB-SL50	175	33	200	62	M6	284	264	G1/8	120	117	94	14	75	56	10	12	95	39	110	138.5	26	90	240	12
MB-SL63	215	38	256	79	M8	312	292	G1/8	130	152	116	18	86	66	11	12	106	46	152	159	29	120	260	13
MB-SL80	260	47	348	96	M8	312	292	G1/8	130	169	116	18	99	79	11	12	119	46	152	185	29	120	260	13

**Mid-Section Support**

(for versions see pages G80 to G83)

Mid-Section supports are required from a certain stroke length to prevent excessive deflection and vibration of the linear drive.

The diagrams show the maximum permissible unsupported length in relation to loading. A distinction must be drawn between loading 1 and loading 2. Deflection of 0.5 mm max. between supports is permissible.

**Note:** For speeds  $v > 0.5$  m/s the distance between supports should not exceed 1 m.

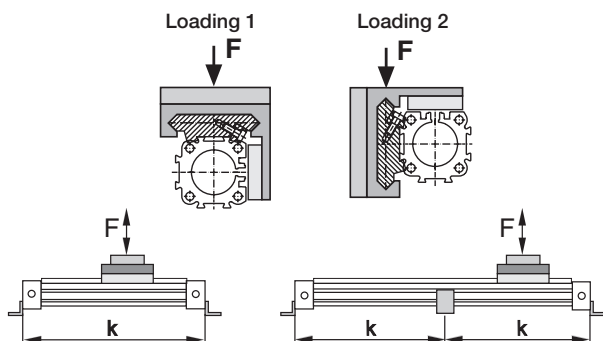

**Permissible Unsupported Length  
 MB-SL25, MB-SL32**

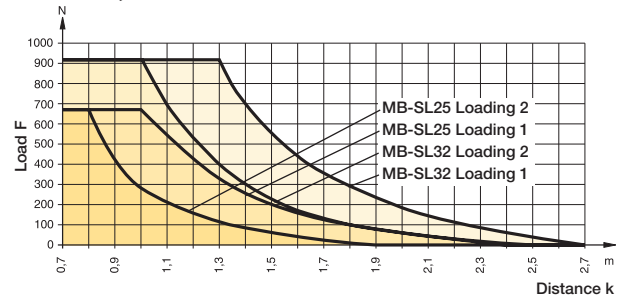

**Permissible Unsupported Length  
 MB-SL40, MB-SL50, MB-SL63 and MB-SL80**

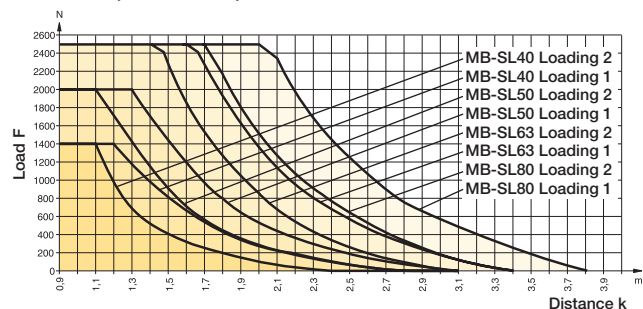

For inventory, lead times, and kit lookup, visit [www.pdnplu.com](http://www.pdnplu.com)

**Features**

**PS ø 16 to 50mm bore**

**Series PS 16 to 50 for Linear-drive**

- Series OSP-P



**Features**

- Anodized aluminum guide carriage with vee rollers having 2 rows of ball bearings
- Several guide sizes can be used on the same drive
- Corrosion resistance version available on request
- Max. Speed  $v = 3$  m/s
- Tough roller cover with wiper and grease nipple
- Any length of stroke up to 3500mm
- Guide Rail: 100cr6 alloy Germany din 17230  
USA ASTM A295 grade 52100

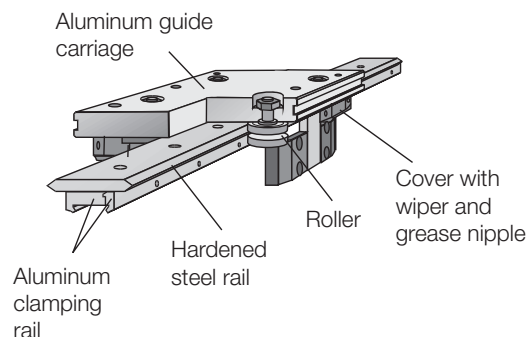
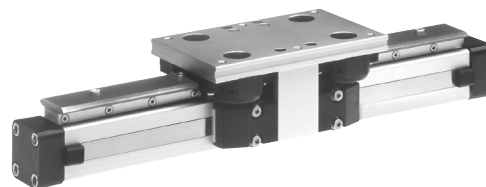

**Loads, Forces and Moments**

The table shows the maximum permissible values for smooth operation, which should not be exceeded even under dynamic conditions.

For further information and technical data see linear drives OSP-P.

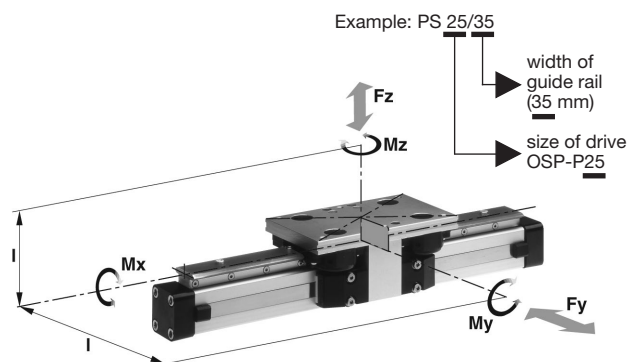

Series	For Linear Drive	Max. Moments (Nm)			Max. Load (N)	Mass of Linear Drive with Guide (kg)		
		Mx	My	Mz		Fy, Fz	With 0mm Stroke	Increase per 100mm Stroke
PS 16/25	OSP-P16	14	45	45	1400	0.93	0.24	0.7
PS 25/25	OSP-P25	14	63	63	1400	1.5	0.4	0.7
PS 25/35	OSP-P25	20	70	70	1400	1.7	0.4	0.8
PS 25/44	OSP-P25	65	175	175	3000	2.6	0.5	1.5
PS 32/35	OSP-P32	20	70	70	1400	2.6	0.6	0.8
PS 32/44	OSP-P32	65	175	175	3000	3.4	0.7	1.5
PS 40/44	OSP-P40	65	175	175	3000	4.6	1.1	1.5
PS 40/60	OSP-P40	90	250	250	3000	6	1.3	2.2
PS 50/60	OSP-P50	90	250	250	3000	7.6	1.4	2.3
PS 50/76	OSP-P50	140	350	350	4000	11.5	1.8	4.9

\* Add the mass of the guide carriage to the mass to be cushioned.

Rodless Pneumatic Cylinders  
 OSP-P Series  
 P1X Series  
 GDL Series



For inventory, lead times, and kit lookup, visit [www.pdnplu.com](http://www.pdnplu.com)

Ordering Information

Ordering information for OSP-P rodless POWERSLIDE pneumatic series

1-4	5-6	7	8	9	10	11	12-16	17	18	19	20	21	22	23	24	25																																																																																																											
<b>OSPP</b>	<b>25</b>	<b>0</b>	<b>1</b>	<b>0</b>	<b>0</b>	<b>0</b>	<b>01100</b>	<b>0</b>	<b>0</b>	<b>0</b>	<b>0</b>	<b>0</b>	<b>0</b>	<b>1</b>	<b>0</b>	<b>0</b>																																																																																																											
<table border="1" style="width:100%; border-collapse: collapse;"> <tr><th colspan="2">Bore</th></tr> <tr><td>16</td><td></td></tr> <tr><td>25</td><td></td></tr> <tr><td>32</td><td></td></tr> <tr><td>40</td><td></td></tr> <tr><td>50</td><td></td></tr> </table>		Bore		16		25		32		40		50		<table border="1" style="width:100%; border-collapse: collapse;"> <tr><th colspan="2">Lubrication</th></tr> <tr><td>0</td><td>Standard</td></tr> <tr><td>1</td><td>Slow Speed</td></tr> </table>		Lubrication		0	Standard	1	Slow Speed	<table border="1" style="width:100%; border-collapse: collapse;"> <tr><th colspan="2">Stroke</th></tr> <tr><td colspan="2">x x x x x</td></tr> <tr><td colspan="2">5 digits in whole millimeters (ex. 1100mm = 01100)</td></tr> </table>		Stroke		x x x x x		5 digits in whole millimeters (ex. 1100mm = 01100)		<table border="1" style="width:100%; border-collapse: collapse;"> <tr><th colspan="2">Cushioning &amp; Stops</th></tr> <tr><td>0</td><td>Standard</td></tr> <tr><td>1</td><td>Long Cushions (25,32,40)</td></tr> </table>		Cushioning & Stops		0	Standard	1	Long Cushions (25,32,40)	<table border="1" style="width:100%; border-collapse: collapse;"> <tr><th colspan="2">Dovetail Cover</th></tr> <tr><td>0</td><td>Standard</td></tr> <tr><td>X</td><td>Without Cover Rail</td></tr> </table>		Dovetail Cover		0	Standard	X	Without Cover Rail	<table border="1" style="width:100%; border-collapse: collapse;"> <tr><th colspan="2">Version</th></tr> <tr><td>0</td><td>Standard</td></tr> </table>		Version		0	Standard	<table border="1" style="width:100%; border-collapse: collapse;"> <tr><th colspan="2">Piston Style</th></tr> <tr><td>0</td><td>Standard</td></tr> <tr><td>1</td><td>Tandem</td></tr> </table>		Piston Style		0	Standard	1	Tandem	<table border="1" style="width:100%; border-collapse: collapse;"> <tr><th colspan="2">Seals</th></tr> <tr><td>0</td><td>Standard</td></tr> <tr><td>1</td><td>Fluorocarbon</td></tr> </table>		Seals		0	Standard	1	Fluorocarbon	<table border="1" style="width:100%; border-collapse: collapse;"> <tr><th colspan="2">Piston Mounting</th></tr> <tr><td>0</td><td>None</td></tr> </table>		Piston Mounting		0	None	<table border="1" style="width:100%; border-collapse: collapse;"> <tr><th colspan="2">Hardware</th></tr> <tr><td>0</td><td>Standard</td></tr> <tr><td>1</td><td>Stainless Steel</td></tr> </table>		Hardware		0	Standard	1	Stainless Steel	<table border="1" style="width:100%; border-collapse: collapse;"> <tr><th colspan="2">Guides / Brakes</th></tr> <tr><td>E</td><td>PSXX/25 (16,25)</td></tr> <tr><td>F</td><td>PSXX/35 (25,32)</td></tr> <tr><td>G</td><td>PSXX/44 (25,32,40)</td></tr> <tr><td>H</td><td>PSXX/60 (40,50)</td></tr> <tr><td>I</td><td>PSXX/76 (50)</td></tr> </table>		Guides / Brakes		E	PSXX/25 (16,25)	F	PSXX/35 (25,32)	G	PSXX/44 (25,32,40)	H	PSXX/60 (40,50)	I	PSXX/76 (50)	<table border="1" style="width:100%; border-collapse: collapse;"> <tr><th colspan="2">Endcap Mounting</th></tr> <tr><td>0</td><td>None</td></tr> <tr><td>1</td><td>A1 (16,25,32)</td></tr> <tr><td>2</td><td>A2 (16,25,32)</td></tr> <tr><td>3</td><td>A3 (25,32)</td></tr> <tr><td>4</td><td>B1 (25,32)</td></tr> <tr><td>6</td><td>B3 (16)</td></tr> <tr><td>7</td><td>B4 (25,32)</td></tr> <tr><td>8</td><td>B5 (32)</td></tr> <tr><td>9</td><td>C1 (40,50)</td></tr> <tr><td>A</td><td>C2 (40,50)</td></tr> <tr><td>B</td><td>C3 (40,50)</td></tr> <tr><td>C</td><td>C4 (40,50)</td></tr> </table> <p>Note: Comes in pairs</p>		Endcap Mounting		0	None	1	A1 (16,25,32)	2	A2 (16,25,32)	3	A3 (25,32)	4	B1 (25,32)	6	B3 (16)	7	B4 (25,32)	8	B5 (32)	9	C1 (40,50)	A	C2 (40,50)	B	C3 (40,50)	C	C4 (40,50)
Bore																																																																																																																											
16																																																																																																																											
25																																																																																																																											
32																																																																																																																											
40																																																																																																																											
50																																																																																																																											
Lubrication																																																																																																																											
0	Standard																																																																																																																										
1	Slow Speed																																																																																																																										
Stroke																																																																																																																											
x x x x x																																																																																																																											
5 digits in whole millimeters (ex. 1100mm = 01100)																																																																																																																											
Cushioning & Stops																																																																																																																											
0	Standard																																																																																																																										
1	Long Cushions (25,32,40)																																																																																																																										
Dovetail Cover																																																																																																																											
0	Standard																																																																																																																										
X	Without Cover Rail																																																																																																																										
Version																																																																																																																											
0	Standard																																																																																																																										
Piston Style																																																																																																																											
0	Standard																																																																																																																										
1	Tandem																																																																																																																										
Seals																																																																																																																											
0	Standard																																																																																																																										
1	Fluorocarbon																																																																																																																										
Piston Mounting																																																																																																																											
0	None																																																																																																																										
Hardware																																																																																																																											
0	Standard																																																																																																																										
1	Stainless Steel																																																																																																																										
Guides / Brakes																																																																																																																											
E	PSXX/25 (16,25)																																																																																																																										
F	PSXX/35 (25,32)																																																																																																																										
G	PSXX/44 (25,32,40)																																																																																																																										
H	PSXX/60 (40,50)																																																																																																																										
I	PSXX/76 (50)																																																																																																																										
Endcap Mounting																																																																																																																											
0	None																																																																																																																										
1	A1 (16,25,32)																																																																																																																										
2	A2 (16,25,32)																																																																																																																										
3	A3 (25,32)																																																																																																																										
4	B1 (25,32)																																																																																																																										
6	B3 (16)																																																																																																																										
7	B4 (25,32)																																																																																																																										
8	B5 (32)																																																																																																																										
9	C1 (40,50)																																																																																																																										
A	C2 (40,50)																																																																																																																										
B	C3 (40,50)																																																																																																																										
C	C4 (40,50)																																																																																																																										
<table border="1" style="width:100%; border-collapse: collapse;"> <tr><th colspan="2">Porting Configurations</th></tr> <tr><td>0</td><td>Standard</td></tr> <tr><td>1</td><td>End Face (16,25,32,40,50)</td></tr> <tr><td>2</td><td>Single End Porting (25,32,40,50)</td></tr> <tr><td>3</td><td>Left Std Pos #2, Right Pos #5 (16,25,32,40,50)</td></tr> <tr><td>4</td><td>Left Pos #5, Right Std Pos #2 (16,25,32,40,50)</td></tr> <tr><td>6</td><td>Single End Porting at #5 (50)</td></tr> <tr><td>A</td><td>24VDC VOE Valves (25,32,40,50)</td></tr> <tr><td>B</td><td>220VAC VOE Valves (25,32,40,50)</td></tr> <tr><td>C</td><td>48VDC VOE Valves (25,32,40,50)</td></tr> <tr><td>E</td><td>110VAC VOE Valves (25,32,40,50)</td></tr> </table> <p>Note: Single end porting on 16mm bore, then end caps cannot be rotated.</p>				Porting Configurations		0	Standard	1	End Face (16,25,32,40,50)	2	Single End Porting (25,32,40,50)	3	Left Std Pos #2, Right Pos #5 (16,25,32,40,50)	4	Left Pos #5, Right Std Pos #2 (16,25,32,40,50)	6	Single End Porting at #5 (50)	A	24VDC VOE Valves (25,32,40,50)	B	220VAC VOE Valves (25,32,40,50)	C	48VDC VOE Valves (25,32,40,50)	E	110VAC VOE Valves (25,32,40,50)	<table border="1" style="width:100%; border-collapse: collapse;"> <tr><th colspan="2">Endcap Position</th></tr> <tr><td>0</td><td>Mounting</td></tr> <tr><td>1</td><td>Both Pos #3</td></tr> <tr><td>2</td><td>Both Pos #4</td></tr> <tr><td>3</td><td>Both Pos #1</td></tr> <tr><td>4</td><td>Left #3 / Right #2</td></tr> <tr><td>5</td><td>Left #4 / Right #2</td></tr> <tr><td>6</td><td>Left #1 / Right #2</td></tr> <tr><td>7</td><td>Left #2 / Right #3</td></tr> <tr><td>8</td><td>Left #4 / Right #3</td></tr> <tr><td>9</td><td>Left #1 / Right #3</td></tr> <tr><td>A</td><td>Left #2 / Right #4</td></tr> <tr><td>B</td><td>Left #3 / Right #4</td></tr> <tr><td>C</td><td>Left #1 / Right #4</td></tr> <tr><td>D</td><td>Left #2 / Right #1</td></tr> <tr><td>E</td><td>Left #3 / Right #1</td></tr> <tr><td>F</td><td>Left #4 / Right #1</td></tr> </table>				Endcap Position		0	Mounting	1	Both Pos #3	2	Both Pos #4	3	Both Pos #1	4	Left #3 / Right #2	5	Left #4 / Right #2	6	Left #1 / Right #2	7	Left #2 / Right #3	8	Left #4 / Right #3	9	Left #1 / Right #3	A	Left #2 / Right #4	B	Left #3 / Right #4	C	Left #1 / Right #4	D	Left #2 / Right #1	E	Left #3 / Right #1	F	Left #4 / Right #1	<table border="1" style="width:100%; border-collapse: collapse;"> <tr><th colspan="2">Additional Carriages**</th></tr> <tr><td>0</td><td>None</td></tr> <tr><td>E</td><td>PSXX/25 (16,25)</td></tr> <tr><td>F</td><td>PSXX/35 (25,32)</td></tr> <tr><td>G</td><td>PSXX/44 (25,32,40)</td></tr> <tr><td>H</td><td>PSXX/50 (40,50)</td></tr> <tr><td>I</td><td>PSXX/76 (50)</td></tr> </table> <p>** Note: Available on tandem piston only</p>				Additional Carriages**		0	None	E	PSXX/25 (16,25)	F	PSXX/35 (25,32)	G	PSXX/44 (25,32,40)	H	PSXX/50 (40,50)	I	PSXX/76 (50)	<table border="1" style="width:100%; border-collapse: collapse;"> <tr><th colspan="2">Switches <sup>◇</sup></th></tr> <tr><td>0</td><td>None</td></tr> <tr><td>1</td><td>Normally Open Reed Switch (16 thru 50)</td></tr> <tr><td>2</td><td>Normally Closed Reed Switch (16 thru 50)</td></tr> <tr><td>3</td><td>PNP Hall Sensor w/Extension Cables (16 thru 50)</td></tr> <tr><td>4</td><td>NPN Hall Sensor w/Extension Cables (16 thru 50)</td></tr> <tr><td>X</td><td>SFI 0.1mm RES (25 thru 50)</td></tr> <tr><td>Y</td><td>SFI 1mm RES (25 thru 50)</td></tr> </table> <p><sup>◇</sup> Note: 2 switches will be supplied. For different quantity, please order as a separate line item.</p>				Switches <sup>◇</sup>		0	None	1	Normally Open Reed Switch (16 thru 50)	2	Normally Closed Reed Switch (16 thru 50)	3	PNP Hall Sensor w/Extension Cables (16 thru 50)	4	NPN Hall Sensor w/Extension Cables (16 thru 50)	X	SFI 0.1mm RES (25 thru 50)	Y	SFI 1mm RES (25 thru 50)																						
Porting Configurations																																																																																																																											
0	Standard																																																																																																																										
1	End Face (16,25,32,40,50)																																																																																																																										
2	Single End Porting (25,32,40,50)																																																																																																																										
3	Left Std Pos #2, Right Pos #5 (16,25,32,40,50)																																																																																																																										
4	Left Pos #5, Right Std Pos #2 (16,25,32,40,50)																																																																																																																										
6	Single End Porting at #5 (50)																																																																																																																										
A	24VDC VOE Valves (25,32,40,50)																																																																																																																										
B	220VAC VOE Valves (25,32,40,50)																																																																																																																										
C	48VDC VOE Valves (25,32,40,50)																																																																																																																										
E	110VAC VOE Valves (25,32,40,50)																																																																																																																										
Endcap Position																																																																																																																											
0	Mounting																																																																																																																										
1	Both Pos #3																																																																																																																										
2	Both Pos #4																																																																																																																										
3	Both Pos #1																																																																																																																										
4	Left #3 / Right #2																																																																																																																										
5	Left #4 / Right #2																																																																																																																										
6	Left #1 / Right #2																																																																																																																										
7	Left #2 / Right #3																																																																																																																										
8	Left #4 / Right #3																																																																																																																										
9	Left #1 / Right #3																																																																																																																										
A	Left #2 / Right #4																																																																																																																										
B	Left #3 / Right #4																																																																																																																										
C	Left #1 / Right #4																																																																																																																										
D	Left #2 / Right #1																																																																																																																										
E	Left #3 / Right #1																																																																																																																										
F	Left #4 / Right #1																																																																																																																										
Additional Carriages**																																																																																																																											
0	None																																																																																																																										
E	PSXX/25 (16,25)																																																																																																																										
F	PSXX/35 (25,32)																																																																																																																										
G	PSXX/44 (25,32,40)																																																																																																																										
H	PSXX/50 (40,50)																																																																																																																										
I	PSXX/76 (50)																																																																																																																										
Switches <sup>◇</sup>																																																																																																																											
0	None																																																																																																																										
1	Normally Open Reed Switch (16 thru 50)																																																																																																																										
2	Normally Closed Reed Switch (16 thru 50)																																																																																																																										
3	PNP Hall Sensor w/Extension Cables (16 thru 50)																																																																																																																										
4	NPN Hall Sensor w/Extension Cables (16 thru 50)																																																																																																																										
X	SFI 0.1mm RES (25 thru 50)																																																																																																																										
Y	SFI 1mm RES (25 thru 50)																																																																																																																										

**Cylinder with guide end cap positioning**

**Sensors**  
See section L for sensors.

**G**  
Rodless Pneumatic Cylinders  
OSP-P Series  
P1X Series  
GDL Series



For inventory, lead times, and kit lookup, visit [www.pdnplu.com](http://www.pdnplu.com)

**POWERSLIDE Dimensions**

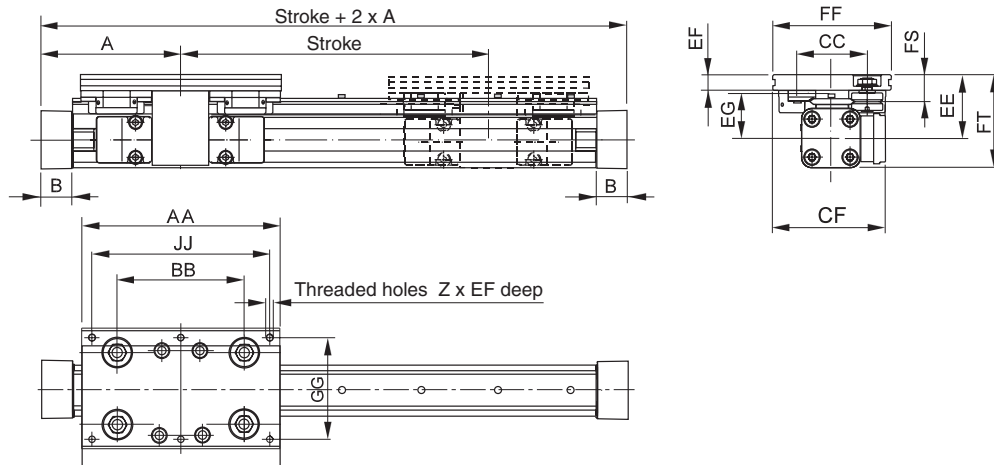

**Dimensions (mm)**

Series	A	B	Z	AA	BB	CC	CF	EE	EF	EG	FF	FS	FT	GG	JJ
PS 16/25	65	14	4xM6	120	65	47	80	49	12	35	80	21	64	64	100
PS 25/25	100	22	6xM6	145	90	47	79.5	53	11	39	80	20	73.5	64	125
PS 25/35	100	22	6xM6	156	100	57	89.5	52.5	12.5	37.5	95	21.5	73	80	140
PS 25/44	100	22	6xM8	190	118	73	100	58	15	39	116	26	78.5	96	164
PS 32/35	125	25.5	6xM6	156	100	57	95.5	58.5	12.5	43.5	95	21.5	84.5	80	140
PS 32/44	125	25.5	6xM8	190	118	73	107	64	15	45	116	26	90	96	164
PS 40/44	150	28	6xM8	190	118	73	112.5	75	15	56	116	26	109.5	96	164
PS 40/60	150	28	6xM8	240	167	89	122.5	74	17	54	135	28.5	108.5	115	216
PS 50/60	175	33	6xM8	240	167	89	130.5	81	17	61	135	28.5	123.5	115	216
PS 50/76	175	33	6xM10	280	178	119	155.5	93	20	64	185	39	135.5	160	250

**Service Life**

Calculation of service life is achieved in two stages:

- Determination of load factor Lf from the loads to be carried
- Calculation of service life in km

**1. Calculation of load factor Lf**

$$LF = \frac{Mx}{Mx_{max}} + \frac{My}{My_{max}} + \frac{Mz}{Mz_{max}} + \frac{Fy}{Fy_{max}} + \frac{Fz}{Fz_{max}}$$

with combined loads, Lf should not exceed the value 1.

**Lubrication**

For maximum system life, lubrication of the rollers must be maintained at all times.

Only high quality Lithium based greases should be used.

Lubrication intervals are dependent on environmental conditions (temperature, running speed, grease quality etc.) therefore the installation should be regularly inspected.

**2. Service life calculation**

- For PS 16/25, PS 25/25, PS 25/35, and PS 32/35

$$\text{Service life (km)} = \frac{106}{(LF + 0,02)^3}$$

- For PS 25/44, PS 32/44, PS 40/44, PS 40/60 and PS 50/60:

$$\text{Service life (km)} = \frac{314}{(LF + 0,015)^3}$$

- For PS 50/76:

$$\text{Service life (km)} = \frac{680}{(LF + 0,015)^3}$$

**G**  
 Rodless Pneumatic Cylinders  
 OSP-P Series  
 P1X Series  
 GDL Series



For inventory, lead times, and kit lookup, visit [www.pdnplu.com](http://www.pdnplu.com)

**Mid-Section Support**

(for versions see page G80 to G83)

Mid-section supports are required from a certain stroke length to prevent excessive deflection and vibration of the linear drive. The diagrams show the maximum permissible unsupported length in relation to loading. A distinction must be drawn between loading 1 and loading 2.

Deflection of 0.5 mm max. between supports is permissible.

**Note:** For speeds  $v > 0.5$  m/s the distance between supports should not exceed 1 m.

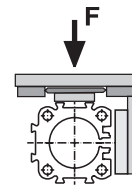

Loading 1

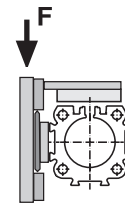

Loading 2

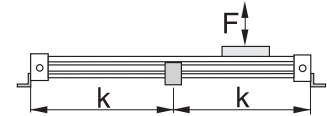
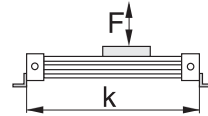

**Permissible unsupported length:  
 POWERSLIDE 16/25, 25/25, 25/35, 25/44mm bore**

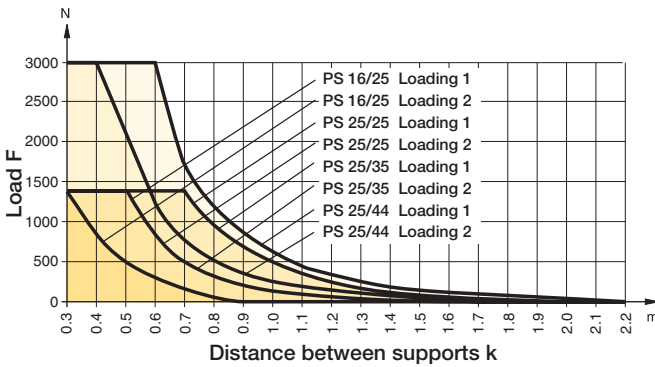

**Permissible unsupported length:  
 POWERSLIDE 2/35, 32/44mm bore**

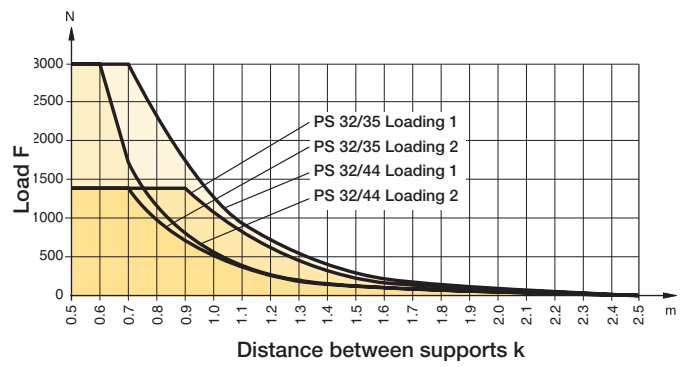

**Permissible unsupported length:  
 POWERSLIDE 40/44, 40/60mm bore**

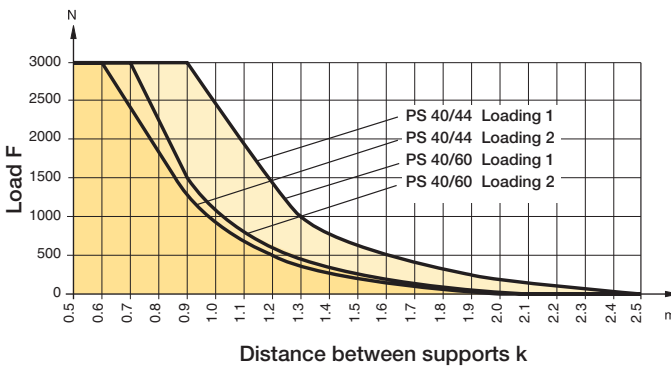

**Permissible unsupported length:  
 POWERSLIDE 50/60, 50/76mm bore**

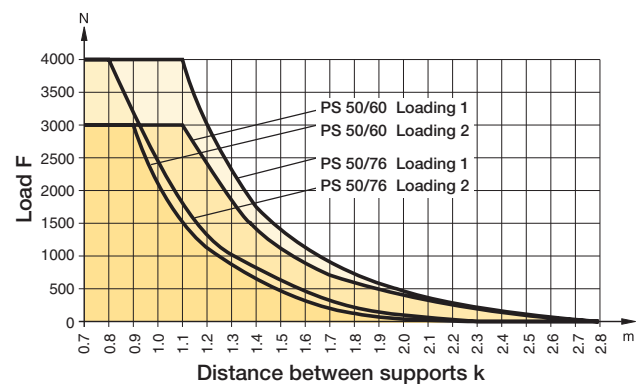

Rodless Pneumatic  
 Cylinders

OSP-P  
 Series

P1X  
 Series

GDL  
 Series



For inventory, lead times, and kit lookup, visit [www.pdnplu.com](http://www.pdnplu.com)

Features

Aluminum Roller Guide PROLINE PL ø 16 to 50mm bore

Series PL 16 to 50 for Linear-drive



- Series OSP-P

Features

- High precision
- High velocities (10 m/s)
- Smooth operation - low noise
- Integrated wiper system
- Long life lubrication
- Compact dimensions - compatible to Slideline plain bearing guide
- Any length of stroke up to 3750mm



Integrated Brake (optional) for Series OSP-P25 to OSP-P50:

- Actuated by pressurization
- Release by depressurization and spring actuation

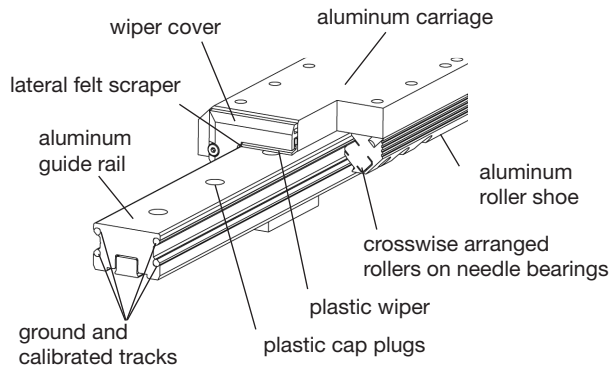

Option – Integrated Brake

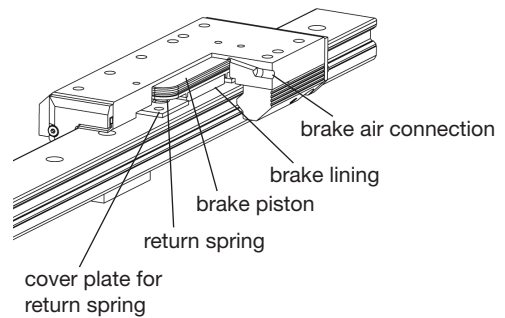

Loads, Forces and Moments

The table shows the maximal permissible loads. If multiple moments and forces act upon the cylinder simultaneously, the following equation applies:

$$\frac{M_x}{M_{x\max}} + \frac{M_y}{M_{y\max}} + \frac{M_z}{M_{z\max}} + \frac{F_y}{F_{y\max}} + \frac{F_z}{F_{z\max}} \leq 1$$

The sum of the loads should not exceed >1. With a load factor of less than 1, service life is 8000 km

The table shows the maximum permissible values for light, shock-free operation, which must not be exceeded even under dynamic conditions.

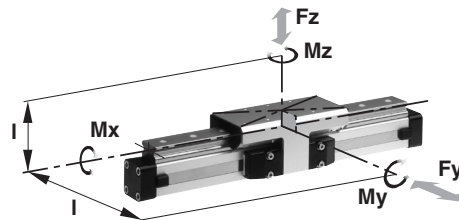

Series	For Linear Drive	Max. Moments (Nm)			Max. Loads (N)	Maximum Braking Force at 6 Bar (N) †	Mass of Linear Drive with Guide (kg)		Mass * Guide Carriage (kg)
		Mx	My	Mz	Fy, Fz		with 0mm Stroke	increase per 100mm Stroke	
PL16	OSP-P16	8	12	12	542	-	0.55	0.19	0.24
PL25	OSP-P25	16	39	39	857	on request	1.65	0.40	0.75
PL32	OSP-P32	29	73	73	1171	on request	3.24	0.62	1.18
PL40	OSP-P40	57	158	158	2074	on request	4.35	0.70	1.70
PL50	OSP-P50	111	249	249	3111	on request	7.03	0.95	2.50

\* Add the mass of the guide carriage to the mass to be cushioned.

† Only for version with brake: Braking surface dry – oiled surface reduces the effective braking force.

G Rodless Pneumatic Cylinders  
 OSP-P Series  
 P1X Series  
 GDL Series



For inventory, lead times, and kit lookup, visit [www.pdnplu.com](http://www.pdnplu.com)

Ordering information for OSP-P rodless PROLINE pneumatic series

1-4	5-6	7	8	9	10	11	12-16	17	18	19	20	21	22	23	24	25
<b>OSP</b>	<b>P</b>	<b>25</b>	<b>0</b>	<b>1</b>	<b>0</b>	<b>0</b>	<b>01100</b>	<b>0</b>	<b>0</b>	<b>0</b>	<b>0</b>	<b>0</b>	<b>0</b>	<b>1</b>	<b>0</b>	<b>0</b>
		<b>Bore</b>				<b>Lubrication</b>	<b>Stroke</b>	<b>Cushioning &amp; Stops</b>					<b>Dovetail Cover</b>	<b>Version</b>		
		16 25 32 40 50				0 Standard 1 Fluorocarbon	xxxxx 5 digits in whole millimeters (ex. 1100mm = 01100)	0 Standard 1 Long Cushions (25,32,40)					0 Standard X Without Cover Rail	0 Standard		
						<b>Seals</b>			<b>Piston Mounting</b>				<b>Endcap Mounting</b>			
						0 Standard 1 Fluorocarbon			0 None				0 None 1 A1 (16,25,32) 2 A2 (16,25,32) 3 A3 (25,32) 4 B1 (25,32) 6 B3 (16) 7 B4 (25,32) 8 B5 (32) 9 C1 (40,50) A C2 (40,50) B C3 (40,50) C C4 (40,50)			
		<b>Piston Style</b>				<b>Hardware</b>							Note: Comes in pairs			
		0 Standard 1 Tandem				0 Standard 1 Stainless Steel										
		<b>Porting Configurations</b>					<b>Guides / Brakes</b>					<b>Endcap Position</b>				
		0 Standard 1 End Face (16,25,32,40,50) 2 Single End Porting (25,32,40,50) 3 Left Std Pos #2, Right Pos #5 (16,25,32,40,50) 4 Left Pos #5, Right Std Pos #2 (16,25,32,40,50) 6 Single End Porting at #5 (50) A 24VDC VOE Valves (25,32,40,50) B 220VAC VOE Valves (25,32,40,50) C 48VDC VOE Valves (25,32,40,50) E 110VAC VOE Valve (25,32,40,50)					6 Proline Guide (16,25,32,40,50) 7 Proline with Activebrake (25,32,40,50) 8 Proline with Multibrake (25, 32,40,50)					0 Both Pos #2 1 Both Pos #3 2 Both Pos #4 3 Both Pos #1 4 Left #3 / Right #2 5 Left #4 / Right #2 6 Left #1 / Right #2 7 Left #2 / Right #3 8 Left #4 / Right #3 9 Left #1 / Right #3 A Left #2 / Right #4 B Left #3 / Right #4 C Left #1 / Right #4 D Left #2 / Right #1 E Left #3 / Right #1 F Left #4 / Right #1				
		Note: Single end porting on 16mm bore, then end caps cannot be rotated.										Additional Carriages** 0 None 6 Proline Guide M Guide Carriage without Brake Function ** Note: Available on tandem piston only				
												<b>Switches</b> ◊ 0 None 1 Normally Open Reed Switch (16 thru 50) 2 Normally Closed Reed Switch (16 thru 50) 3 PNP Hall Sensor w/Extension Cables (16 thru 50) 4 NPN Hall Sensor w/Extension Cables (16 thru 50) X SFI 0.1mm RES (25 thru 50) Y SFI 1mm RES (25 thru 50) ◊ Note: 2 switches will be supplied. For different quantity, please order as a separate line item.				

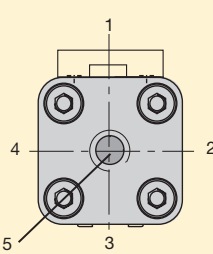

Note: Position #2 is the standard location.

**Sensors**  
See section L for sensors.



G  
Rodless Pneumatic Cylinders  
OSP-P Series  
P1X Series  
GDL Series



For inventory, lead times, and kit lookup, visit [www.pdnplu.com](http://www.pdnplu.com)



**OSP-P PROLINE PL16, PL25, PL32, PL40, PL50**

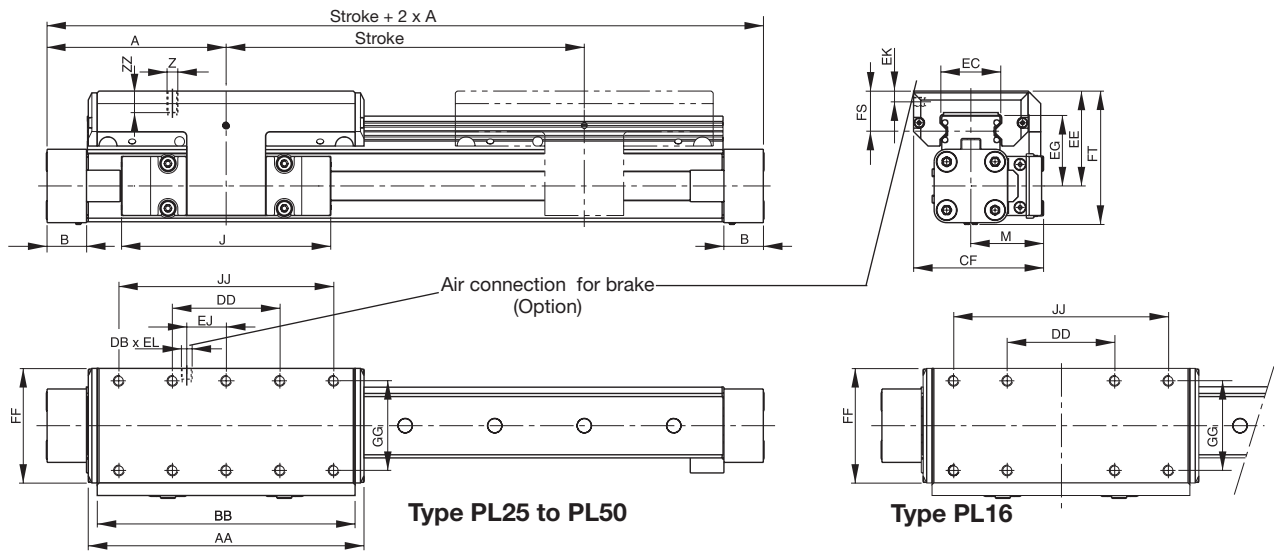

**Dimension (mm)**

Series	A	B	J	M	Z	AA	BB	DB	DD	CF	EC	EE	EG	EJ	EK	EL	FF	FS	FT	GG	JJ	ZZ
PL16	65	14	69	31	M4	98	88	-	30	55	23	40	30	-	-	-	48	17	55	36	70	8
PL25	100	22	117	40.5	M6	154	144	M5	60	72.5	32.5	53	39	22	6	6	64	23	73.5	50	120	12
PL32	125	25.5	152	49	M6	197	187	M5	80	91	42	62	48	32	6	6	84	25	88	64	160	12
PL40	150	28	152	55	M6	232	222	M5	100	102	47	64	50.5	58	6	6	94	23.5	98.5	78	200	12
PL50	175	33	200	62	M6	276	266	M5	120	117	63	75	57	81	6	6	110	29	118.5	90	240	16

**Mid-Section Support**

(For versions, see page G80 to GG83)

Mid-section supports are required from a certain stroke length to prevent excessive deflection and vibration of the linear drive. The diagrams

show the maximum permissible unsupported length in relation to loading. A distinction must be drawn between loading 1 and loading 2. Deflection of 0.5 mm max. between supports is permissible.

**Note:** For speeds  $v > 0.5$  m/s the distance between supports should not exceed 1 m.

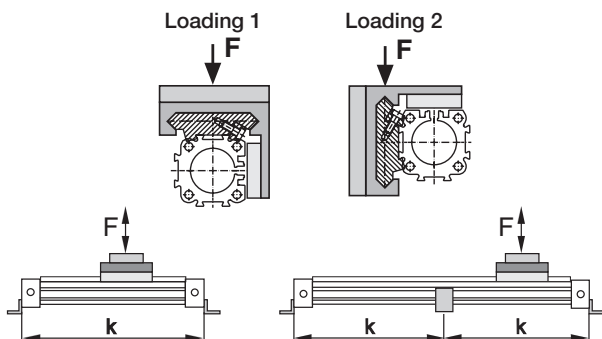

**Permissible Unsupported Length  
 PL16, PL25, PL32, PL40 and PL50**

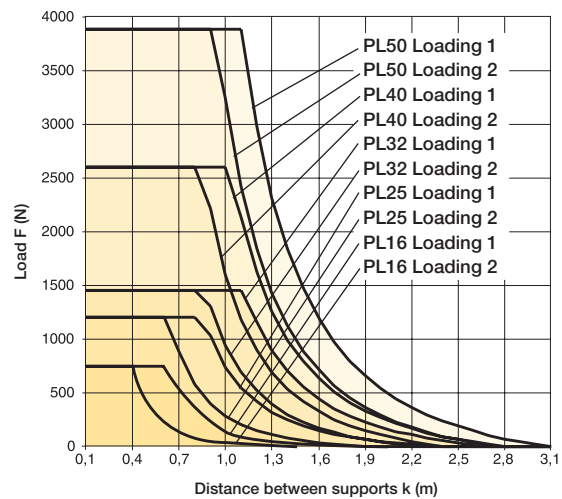



**Features**

**Multi-Brake Passive Brake with Aluminum Roller Guide PROLINE PL 25 to 50mm bore**

**Series MB-PL 25 to 50 for Linear-drive**



- Series OSP-P

**Features**

- Brake operated by spring actuation
- Brake release by pressurization
- Optional sensor to indicate brake lining wear
- Composite sealing system with plastic and felt wiper elements to remove dirt and lubricate the slideway
- Blocking function in case of pressure loss
- Intermediate stops possible

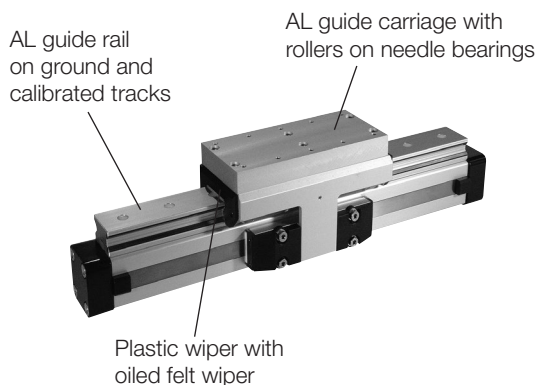

**Function**

The Multi-Brake is a passive device. When the air pressure is removed the brake is actuated and movement of the cylinder is blocked. The brake is released by pressurization.

The high friction, wear resistant brake linings allow the Multi-Brake to be used as a dynamic brake to stop cylinder movement in the shortest possible time. The powerful springs also allow the Multi-Brake to be used effectively in positioning applications.

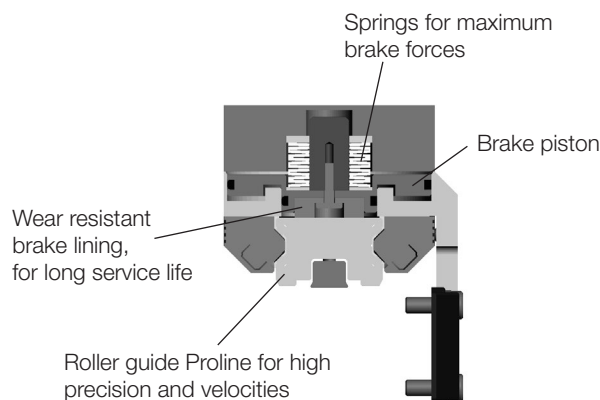

**Loads, Forces and Moments**

The table shows the maximal permissible loads. If multiple moments and forces act upon the cylinder simultaneously, the following equation applies:

$$\frac{M_x}{M_{xmax}} + \frac{M_y}{M_{ymax}} + \frac{M_z}{M_{zmax}} + \frac{F_y}{F_{ymax}} + \frac{F_z}{F_{zmax}} \leq 1$$

**The sum of the loads should not exceed >1. With a load factor of less than 1, service life is 8000 km**

The table shows the maximum permissible values for light, shock-free operation, which must not be exceeded even under dynamic conditions.

Operating Pressure 4.5 - 8 bar.

A pressure of min. 4.5 bar release the brake.

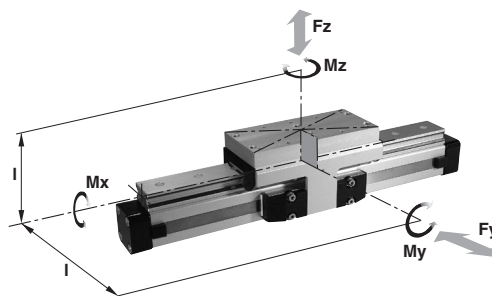

Series	For Linear Drive	Max. Moments (Nm)			Max. Loads (N)		Mass of Linear Drive with Guide (kg)		
		Mx	My	Mz	Fy, Fz	Max. Braking Force (N) †	With 0mm Stroke	Increase per 100mm Stroke	Mass* Guide Carriage (kg)
<b>MB-PL25</b>	OSP-P25	16	39	39	857	315	2.14	0.40	1.24
<b>MB-PL32</b>	OSP-P32	29	73	73	1171	490	4.08	0.62	2.02
<b>MB-PL40</b>	OSP-P40	57	158	158	2074	715	5.46	0.70	2.82
<b>MB-PL50</b>	OSP-P50	111	249	249	3111	1100	8.60	0.95	4.07

\* Add the mass of the guide carriage to the mass to be cushioned.

† Only for version with brake: Braking surface dry – oiled surface reduces the effective braking force.



For inventory, lead times, and kit lookup, visit [www.pdnplu.com](http://www.pdnplu.com)

G55

**Parker Hannifin Corporation**  
 Pneumatic Division  
 Wadsworth, Ohio  
[www.parker.com/pneumatics](http://www.parker.com/pneumatics)



Rodless Pneumatic Cylinders

OSP-P Series

P1X Series

GDL Series

**OSP-P with PROLINE Passive Brake MB-PL25, PL32, PL40, PL50**

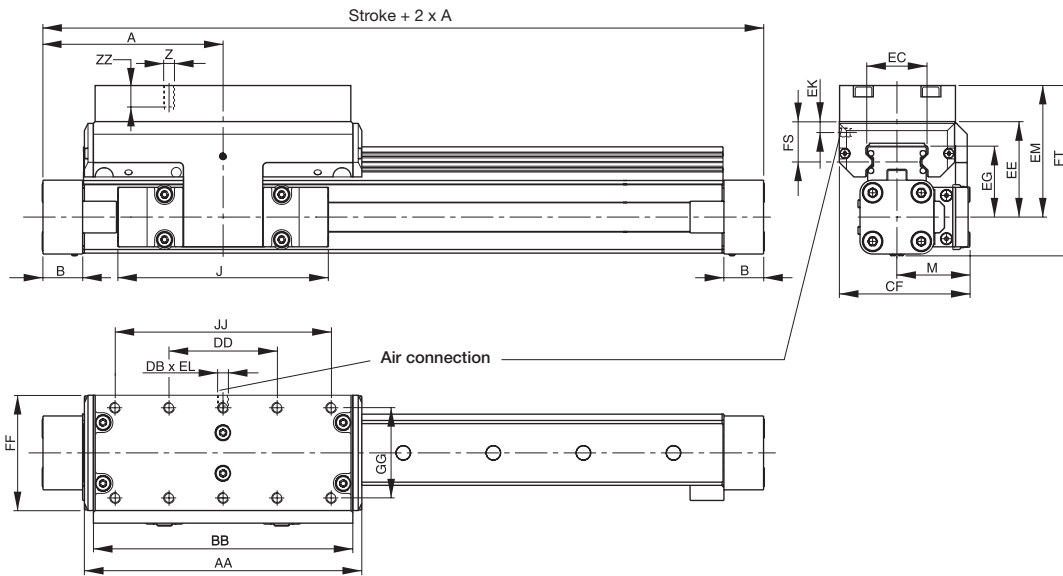

**Dimension (mm)**

Series	A	B	J	M	Z	AA	BB	DB	DD	CF	EC	EE	EG	EK	EL	EM	FF	FS	FT	GG	JJ	ZZ
MB-PL25	100	22	117	40.5	M6	154	144	M5	60	72.5	32.5	53	39	9	5	73	64	23	93.5	50	120	12
MB-PL32	125	25.5	152	49	M6	197	187	G1/8	80	91	42	62	48	7	10	82	84	25	108	64	160	12
MB-PL40	150	28	152	55	M6	232	222	G1/8	100	102	47	64	50.5	6.5	10	84	94	23.5	118.5	78	200	12
MB-PL50	175	33	200	62	M6	276	266	G1/8	120	117	63	75	57	10	12	95	110	29	138.5	90	240	16

**Mid-Section Support**

(for versions see page G80 to G83)

Mid-Section supports are required from a certain stroke length to prevent

excessive deflection and vibration of the linear drive. The diagrams show the maximum permissible unsupported length in relation to loading.

A distinction must be drawn between loading 1 and loading 2. Deflection of 0.5 mm max. between supports is permissible.

**Note:** For speeds  $v > 0.5$  m/s the distance between supports should not exceed 1 m.

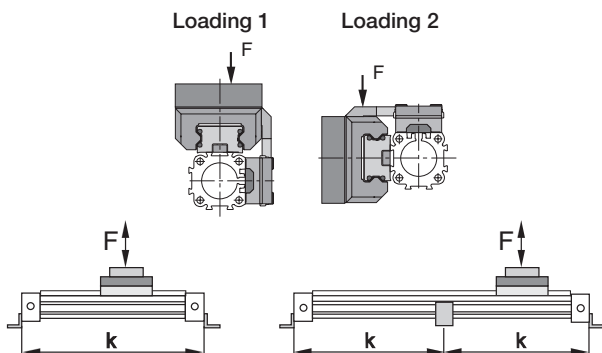

**Permissible Unsupported Length OSP-P  
 MB-PL25, MB-PL32, MB-PL40, MB-PL50**

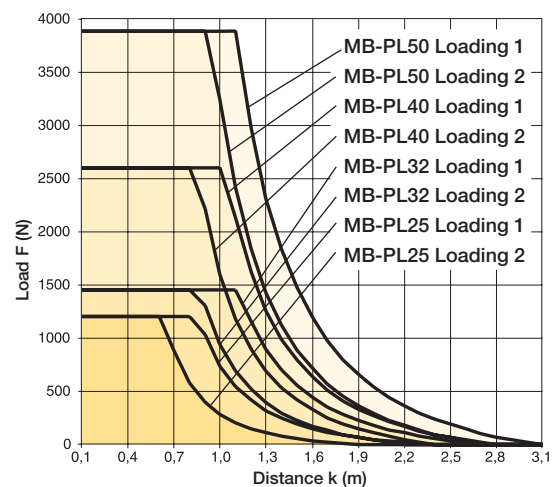

**Recirculating Ball Bearing Guide STARLINE PL 16 to 50mm bore**

**Series PL 16 to 50 for Linear-drive**

- Series OSP-P

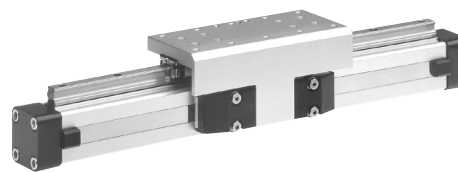

**Features**

- Polished and hardened steel guide rail
- For very high loads in all directions
- High precision
- Integrated wiper system
- Integrated grease nipples
- Any length of stroke up to 3700 mm
- Anodized aluminum guide carriage – dimensions compatible with OSP guides SLIDELINE and PROLINE
- Installation height (STL16 - 32) compatible with OSP guides SLIDELINE and PROLINE
- Maximum speed  
STL16: v = 3 m/s  
STL25 to 50: v = 5 m/s

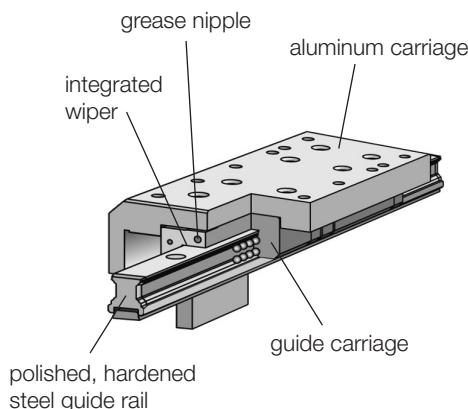

**Loads, Forces and Moments**

The table shows the maximum permissible loads. If multiple moments and forces act upon the cylinder simultaneously, the following equation applies:

$$\frac{M_x}{M_{xmax}} + \frac{M_y}{M_{ymax}} + \frac{M_z}{M_{zmax}} + \frac{F_y}{F_{ymax}} + \frac{F_z}{F_{zmax}} \leq 1$$

The sum of the loads should not exceed >1.

The table shows the maximum permissible values for light, shock-free operation, which must not be exceeded even under dynamic conditions.

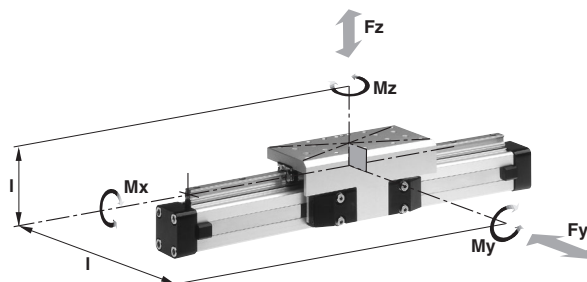

Series	For Linear Drive	Max. Moments (Nm)		Max. Loads (N)			Mass of Linear Drive with Guide (kg)		
		Mx	My	Mz	Fy	Fz	with 0mm Stroke	increase per 100mm Stroke	Mass * Guide Carriage (kg)
STL16	OSP-P16	15	30	30	1000	1000	0.598	0.210	0.268
STL25	OSP-P25	50	110	110	3100	3100	1.733	0.369	0.835
STL32	OSP-P32	62	160	160	3100	3100	2.934	0.526	1.181
STL40	OSP-P40	150	400	400	4000	7500	4.452	0.701	1.901
STL50	OSP-P50	210	580	580	4000	7500	7.361	0.936	2.880

\* Add the mass of the guide carriage to the mass to be cushioned.

**G**

Rodless Pneumatic Cylinders

---

OSP-P Series

---

P1X Series

---

GDL Series



For inventory, lead times, and kit lookup, visit [www.pdnplu.com](http://www.pdnplu.com)

Ordering information for OSP-P rodless STARLINE pneumatic series

1-4	5-6	7	8	9	10	11	12-16	17	18	19	20	21	22	23	24	25
<b>OSP</b>	<b>P</b>	<b>25</b>	<b>0</b>	<b>1</b>	<b>0</b>	<b>0</b>	<b>01100</b>	<b>0</b>	<b>0</b>	<b>0</b>	<b>B</b>	<b>0</b>	<b>0</b>	<b>1</b>	<b>0</b>	<b>0</b>
		<b>Bore</b>				<b>Lubrication</b>	<b>Stroke</b>				<b>Piston Mounting</b>	<b>Dovetail Cover</b>		<b>Version</b>		
		16 25 32 40 50				0 Standard	xxxxx 5 digits in whole millimeters (ex. 1100mm = 01100)				0 None	0 Standard X Without Cover Rail		0 Standard		
		<b>Piston Style</b>			<b>Seals</b>			<b>Cushioning &amp; Stops</b>			<b>Endcap Mounting</b>					
		0 Standard 1 Tandem			0 Standard 1 Fluorocarbon			0 Standard 1 Long Cushions (25,32,40) 2 VS Soft Left 3 VS Hard Left 4 VS Soft Right 5 VS Hard Right 6 VS Soft Both Sides 7 VS Hard Both Sides			0 None 4 B1 (25,32) 6 B3 (16) 7 B4 (25,32) 8 B5 (32) 9 C1 (40,50) A C2 (40,50) B C3 (40,50) C C4 (40,50)					
					<b>Hardware</b>						<b>Guides / Brakes</b>		<b>Switches</b> <sup>◇</sup>			
					0 Standard						B Starline Guide		0 None 1 Normally Open Reed Switch (16 thru 50) 2 Normally Closed Reed Switch (16 thru 50) 3 PNP Hall Sensor w/Extension Cables (16 thru 50) 4 NPN Hall Sensor w/Extension Cables (16 thru 50) X SFI 0.1mm RES (25 thru 50) Y SFI 1mm RES (25 thru 50)			
		<b>Porting Configurations</b>						<b>Endcap Position</b>			<b>Additional Carriages</b> **		<sup>◇</sup> Note: 2 switches will be supplied. For different quantity, please order as a separate line item.			
		0 Standard 1 End Face (16,25,32,40,50) 2 Single End Porting (25,32,40,50) 3 Left Std Pos #2, Right Pos #5 (16,25,32,40,50) 4 Left Pos #5, Right Std Pos #2 (16,25,32,40,50) 6 Single End Porting at #5 (50) A 24VDC VOE valves (25,32,40,50) B 220VAC VOE valves (25,32,40,50) C 48VDC VOE valves (25,32,40,50) E 110VAC VOE valves (25,32,40,50)						0 Both Pos #2 1 Both Pos #3 2 Both Pos #4 3 Both Pos #1 4 Left #3 / Right #2 5 Left #4 / Right #2 6 Left #1 / Right #2 7 Left #2 / Right #3 8 Left #4 / Right #3 9 Left #1 / Right #3 A Left #2 / Right #4 B Left #3 / Right #4 C Left #1 / Right #4 D Left #2 / Right #1 E Left #3 / Right #1 F Left #4 / Right #1 S Special			0 None B Starline					
											0 None B Starline					
											** Note: Available on tandem piston only					

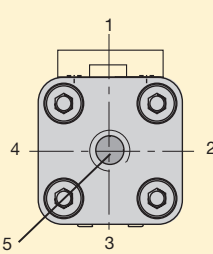

Note: Position #2 is the standard location.

**Sensors**  
See section L for sensors.



**G** Rodless Pneumatic Cylinders  
 OSP-P Series  
 P1X Series  
 GDL Series



For inventory, lead times, and kit lookup, visit [www.pdnplu.com](http://www.pdnplu.com)

OSP-P with STARLINE Recirculating Ball Bearing Guide STL16, STL25, STL32, STL40, STL50

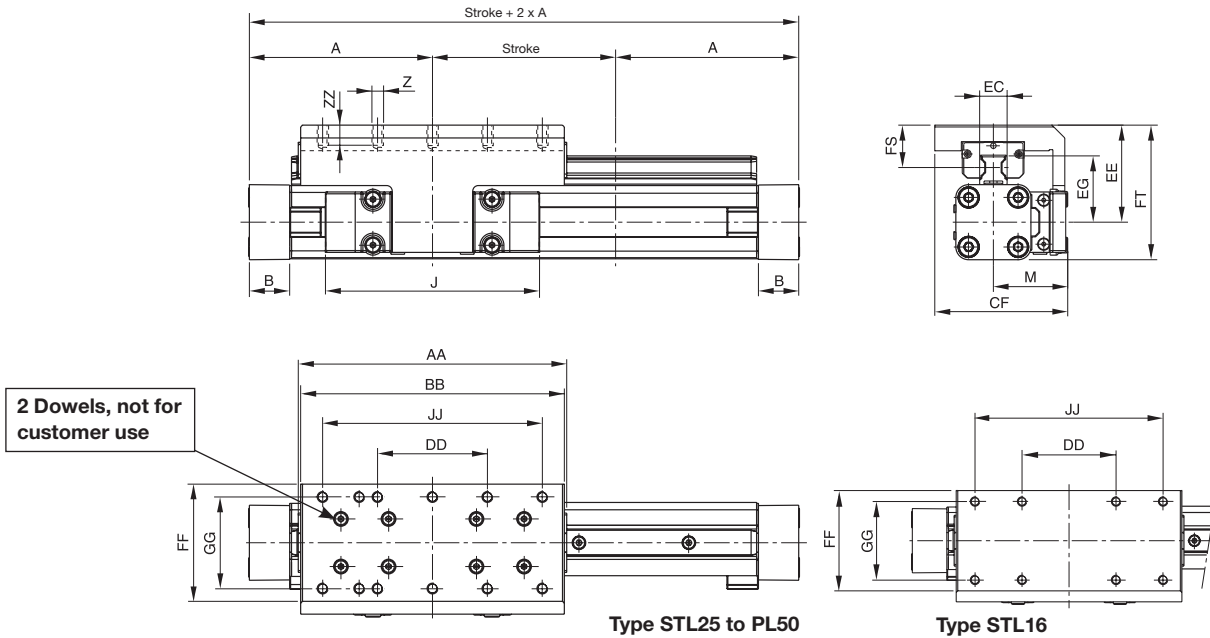

Dimension (mm)

Series	A	B	J	M	Z	AA	BB	CF	DD	EC	EE	EG	FF	FS	FT	GG	JJ	ZZ
STL16	65	14	69	31	M4	93	90	55	30	15	40	24.6	48	18	55	36	70	8
STL25	100	22	117	40.5	M6	146.6	144	72.5	60	15	53	36.2	64	23.2	73.5	50	120	12
STL32	125	25.5	152	49	M6	186.6	184	91	80	15	62	42.2	84	26.2	88	64	160	12
STL40	150	28	152	55	M6	231	226	102	100	20	72	51.6	94	28.5	106.5	78	200	12
STL50	175	33	200	62	M6	270.9	266	117	120	23	85	62.3	110	32.5	128.5	90	240	16

Mid-Section Support

(for versions see pages G80 to G83)

Mid-section supports are required from a certain stroke length to prevent excessive deflection and vibration of the linear drive. The diagrams show the maximum permissible unsupported length in relation to loading. A distinction must be drawn between loading 1 and loading 2. Deflection of 0.5 mm max. between supports is permissible.

**Note:** For speeds  $v > 0.5$  m/s the distance between supports should not exceed 1 m.

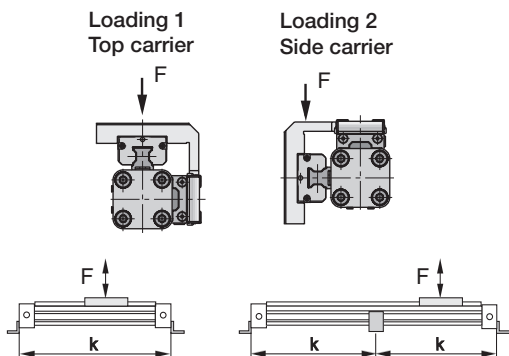

Permissible Unsupported Length STL16 to STL50

Loading 1 Top carrier

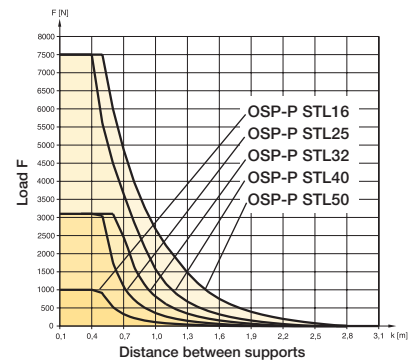

Permissible Unsupported Length STL16 to STL50

Loading 2 Side carrier

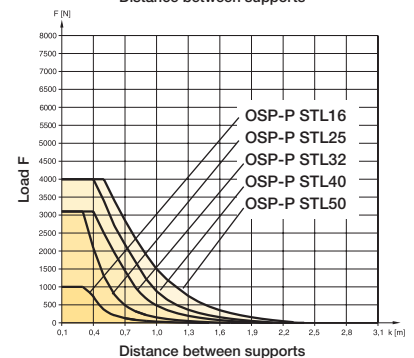

Rodless Pneumatic Cylinders

OSP-P Series

P1X Series

GDL Series



For inventory, lead times, and kit lookup, visit [www.pdnplu.com](http://www.pdnplu.com)

### Variable Stop Type VS16 to VS50

The variable stop Type VS provides simple stroke limitation. It can be retrofitted and positioned anywhere along the stroke length.

For every cylinder diameter two types of shock absorber are available – see “Shock Absorber Selection” below.

Mid-section supports and magnetic switches can still be fitted on the same side as the variable stop.

Depending on the application, two variable stops can be fitted if required.

Arrangement with two variable stops

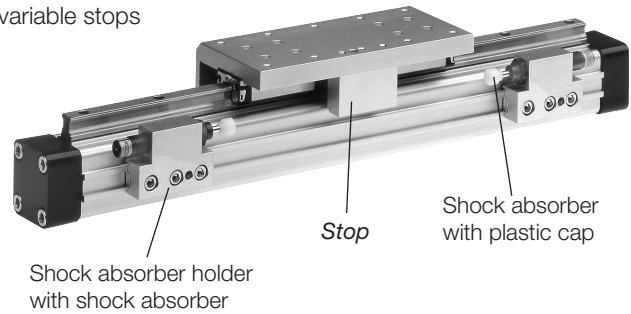

### Shock Absorber Selection

The shock absorber is selected in dependence on the mass and speed.

The mass of the carrier itself must be taken into account.

#### Series OSP-STL16

The values relate to an effective driving force of 78 N (6 bar)

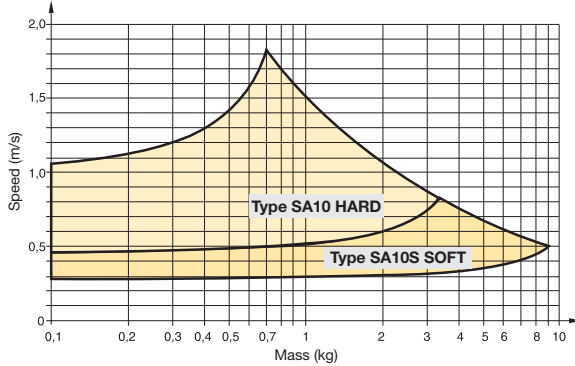

#### Series OSP-STL25

The values relate to an effective driving force of 250 N (6 bar)

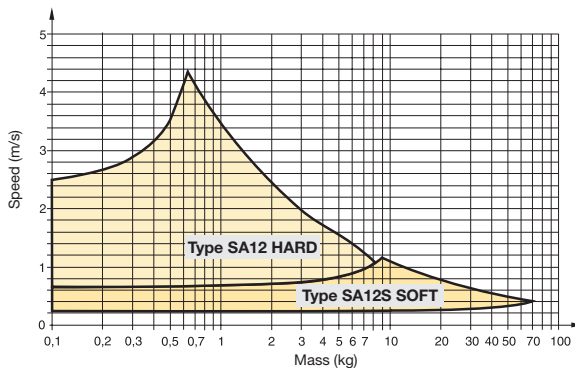

#### Series OSP-STL32

The values relate to an effective driving force of 420 N (6 bar)

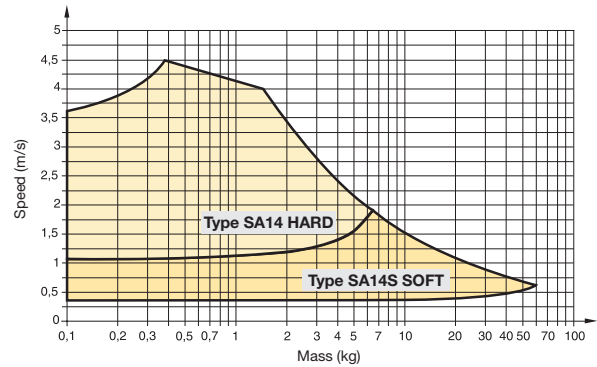

#### Series OSP-STL40

The values relate to an effective driving force of 640 N (6 bar)

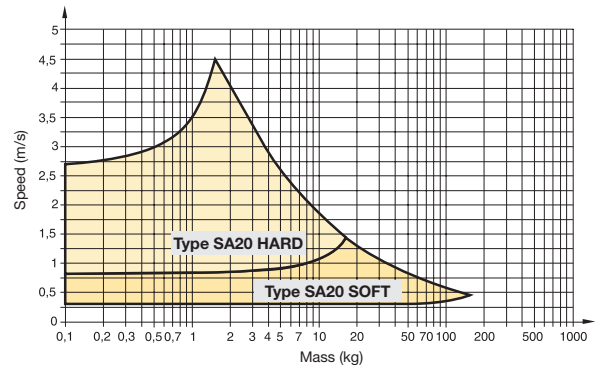

#### Series OSP-STL50

The values relate to an effective driving force of 1000 N (6 bar)

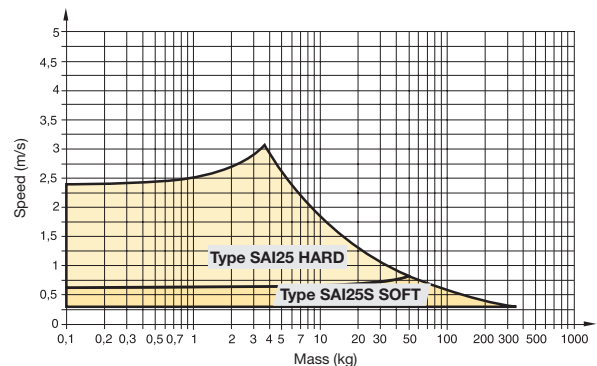

**G**  
 Rodless Pneumatic Cylinders  
 OSP-P Series  
 P1X Series  
 GDL Series



For inventory, lead times, and kit lookup, visit [www.pdnplu.com](http://www.pdnplu.com)

Ordering Information – Variable Stop Type VS16 to VS50

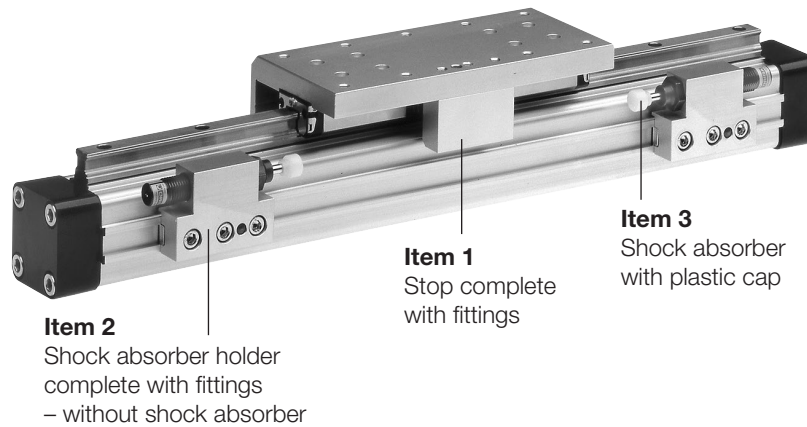

Item	Description	Size	VS16		VS25		VS32		VS40		VS50	
		Type	Part Number	Type	Part Number	Type	Part Number	Type	Part Number	Type	Part Number	
1	Stop, complete	-	21196FIL	-	21197FIL	-	21198FIL	-	21199FIL	-	21200FIL	
2	Shock absorber holder, complete	-	21201FIL	-	21202FIL	-	21203FIL	-	21204FIL	-	21205FIL	
3 *	Shock absorber, standard	SA10	MC25M	SA12	MC75M-1	SA14	MC150M-B	SA20	MC225M	SAI25	MC600M	
	Shock absorber, version S	SA10S	MC25MH	SA12S	MC75M-2	SA14S	MC150MH-B	SA20S	MC225MH	SAI25S	MC600MH	

\* Shock absorber with plastic cap

Dimension – Variable Stop Type VS16 to VS50

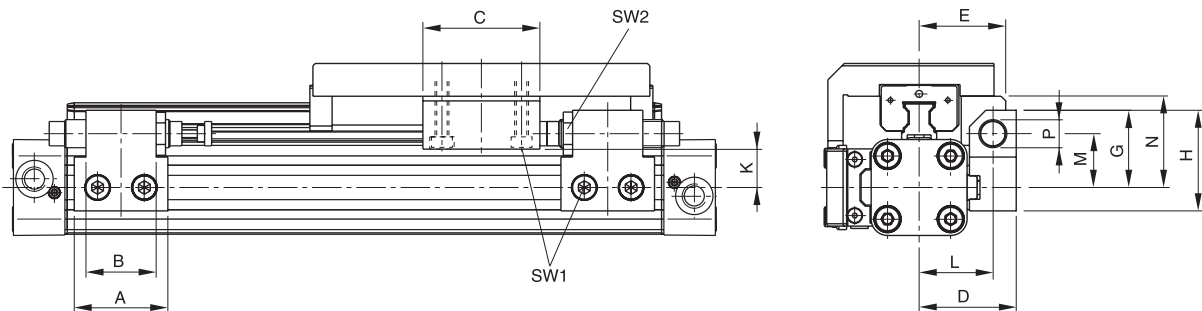

Series	Type	A	B	C	D	E	G	H	K	L	M	N	P	SW1	SW2
OSP-STL16	VS16	30	14	25	33	30	28	38	16.2	25.5	20.5	30	M10x1	4	12.5
OSP-STL25	VS25	40	30	50	41.5	37	33	43	18	31.5	23	39	M12x1	5	16
OSP-STL32	VS32	60	40	50	45.5	42	35	45	19	35.5	25	48	M14x1.5	5	17
OSP-STL40	VS40	84	52	60	64	59	48	63	25.6	50	34	58.6	M20x1.5	5	24
OSP-STL50	VS50	84	-	60	75	69	55	70	26.9	57	38	66.9	M25x1.5	5	30



**Features**

**Recirculating Ball Bearing Guide KF 16 to 50mm bore**

Series KF16 to KF50 for Linear-drive



- Series OSP-P CLASSIC

**Features**

- Anodized aluminum guide carriage, the mounting dimensions correspond to FESTO Type: DGPL-KF
- Polished and hardened steel guide rail
- For high loads in all directions
- High precision
- Integrated wiper system
- Integrated grease nipples
- Any length of stroke up to 3700 mm
- Maximum speed  
KF16, KF40: v = 3 m/s  
KF25, KF32, KF50: v = 5 m/s



**Loads, Forces and Moments**

The table shows the maximum permissible loads. If multiple moments and forces act upon the cylinder simultaneously, the following equation applies:

$$\frac{M_x}{M_{xmax}} + \frac{M_y}{M_{ymax}} + \frac{M_z}{M_{zmax}} + \frac{F_y}{F_{ymax}} + \frac{F_z}{F_{zmax}} \leq 1$$

The sum of the loads should not exceed >1.

The table shows the maximum permissible values for light, shock-free operation, which must not be exceeded even under dynamic conditions.

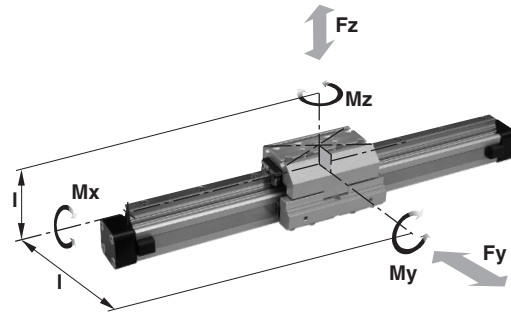

Series	For Linear Drive	Max. Moments (Nm)			Max. Load (N)		Mass of Drive with Guide (kg)			
		Mx	My	Mz	Fy	Fz	with 0mm Stroke	Increase per 100mm Stroke	Mass * Guide Carriage (kg)	Groove Stone Thread Size
KF16	OSP-P16	12	25	25	1000	1000	0.558	0.21	0.228	–
KF25	OSP-P25	35	90	90	3100	3100	1.522	0.369	0.607	M5
KF32	OSP-P32	44	133	133	3100	3100	2.673	0.526	0.896	M5
KF40	OSP-P40	119	346	346	4000	7100	4.167	0.701	1.531	M6
KF50	OSP-P50	170	480	480	4000	7500	7.328	0.936	2.760	M8

\*Add the mass of the guide carriage to the mass to be cushioned.

**G**  
 Rodless Pneumatic Cylinders  
 OSP-P Series  
 P1X Series  
 GDL Series



For inventory, lead times, and kit lookup, visit [www.pdnplu.com](http://www.pdnplu.com)



Ordering information for OSP-P rodless KF pneumatic series

1-4	5-6	7	8	9	10	11	12-16	17	18	19	20	21	22	23	24	25			
<b>OSP</b>	<b>PP</b>	<b>25</b>	<b>0</b>	<b>1</b>	<b>0</b>	<b>0</b>	<b>0</b>	<b>0</b>	<b>0</b>	<b>0</b>	<b>0</b>	<b>C</b>	<b>0</b>	<b>0</b>	<b>1</b>	<b>0</b>	<b>0</b>		
		<b>Bore</b>				<b>Lubrication</b>		<b>Stroke</b>		<b>Piston Mounting</b>		<b>Dovetail Cover</b>		<b>Version</b>					
		16 25 32 40 50				0 Standard 1 Fluorocarbon		xxxxx 5 digits in whole millimeters (ex. 1100mm = 01100)		0 None		0 Standard X Without Cover Rail		0 Standard					
		<b>Piston Style</b>				<b>Hardware</b>				<b>Cushions / Stops</b>				<b>Endcap Mounting</b>					
		C Classic T Tandem Classic				0 Standard				0 Standard 1 Long Cushions (25,32,40) 2 VS Soft Left 3 VS Hard Left 4 VS Soft Right 5 VS Hard Right 6 VS Soft Both Sides 7 VS Hard Both Sides				0 None 4 B1 (25,32) 6 B3 (16) 7 B4 (25,32) 8 B5 (32) 9 C1 (40,50) A C2 (40,50) B C3 (40,50) C C4 (40,50)		Note: Comes in pairs			
		<b>Porting Configurations</b>																	
		0 Standard 1 End Face (16,25,32,40,50) 2 Single End Porting (25,32,40,50) 3 Left Std Pos #2, Right Pos #5 (16,25,32,40,50) 4 Left Pos #5, Right Std Pos #2 (16,25,32,40,50) 6 Single End Porting at #5 (50) A 24VDC VOE Valves (25,32,40,50) B 220VAC VOE Valves (25,32,40,50) C 48VDC VOE Valves (25,32,40,50) E 110VAC VOE Valves (25,32,40,50)																	
		Note: Single end porting on 16mm bore, then end caps cannot be rotated.																	
								<b>Endcap Position</b>											
								0 Both Pos #2 1 Both Pos #3 2 Both Pos #4 3 Both Pos #1 4 Left #3 / Right #2 5 Left #4 / Right #2 6 Left #1 / Right #2 7 Left #2 / Right #3 8 Left #4 / Right #3 9 Left #1 / Right #3 A Left #2 / Right #4 B Left #3 / Right #4 C Left #1 / Right #4 D Left #2 / Right #1 E Left #3 / Right #1 F Left #4 / Right #1											
												<b>Guides / Brakes</b>							
												C KF Guide							
												<b>Additional Carriages**</b>							
												0 None C KF							
												** Note: Available on tandem piston only							
														<b>Switches ◊</b>					
														0 None 1 Normally Open Reed Switch (16 thru 50) 2 Normally Closed Reed Switch (16 thru 50) 3 PNP Hall Sensor w/Extension Cables (16 thru 50) 4 NPN Hall Sensor w/Extension Cables (16 thru 50)					
														◊ Note: 2 switches will be supplied. For different quantity, please order as a separate line item.					

  

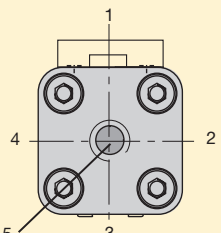

**Note: Position #2 is the standard location.**

  

**Sensors**  
See section L for sensors.



G  
Rodless Pneumatic Cylinders  
OSP-P Series  
P1X Series  
GDL Series

**Series OSP-P KF16 to KF50**

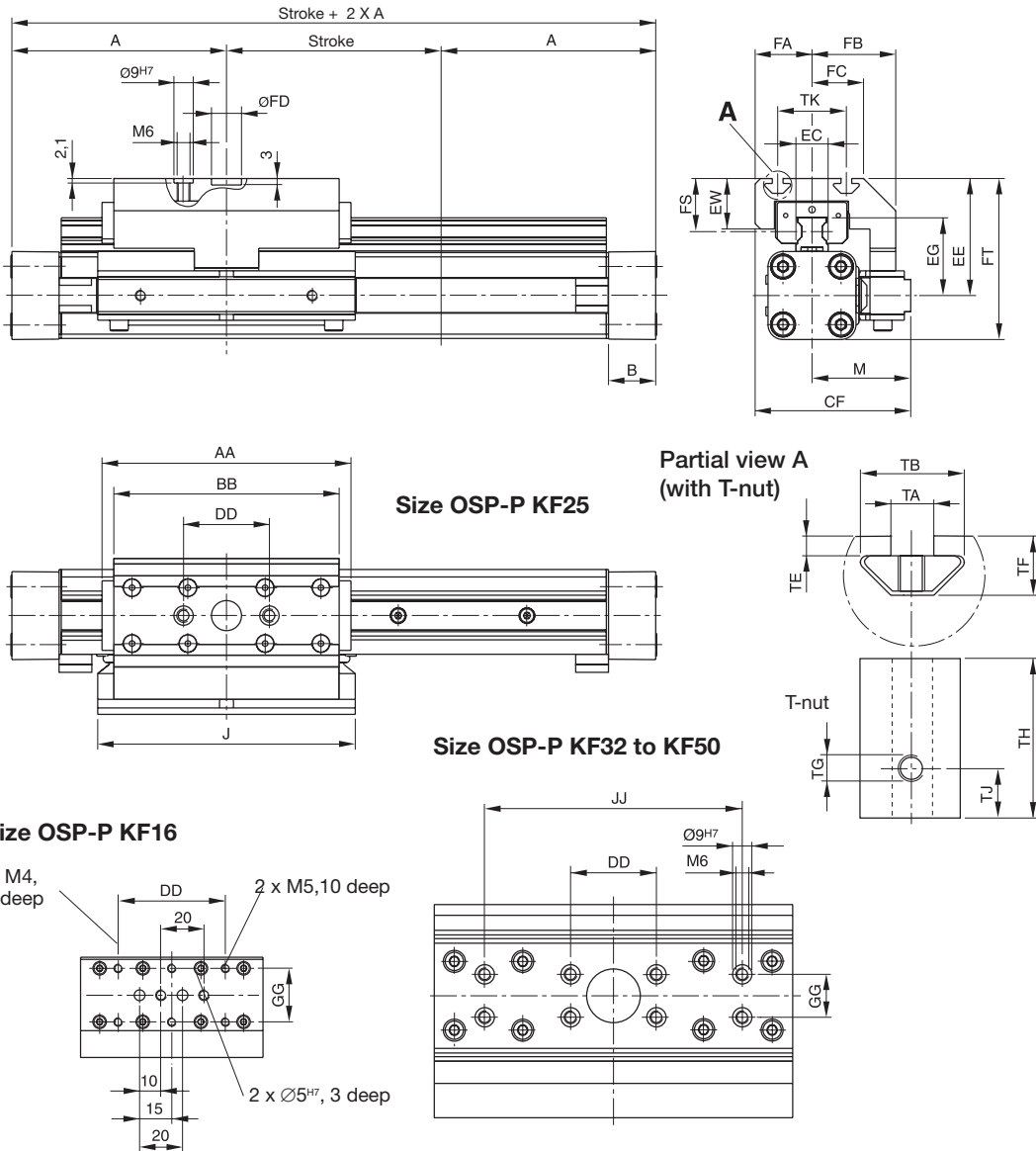

**Dimension (mm) Series OSP-P KF16, KF25, KF32, KF40, KF50**

Series	A	B	J	AA	BB	CF	DD	EC	EE	EG	EW	JJ	GG	M
KF16	65	14	76	93	85	48	50	15	41	24.6	10	-	25	30
KF25	100	22	120	120.2	105	72.5	40	15	54.5	36.2	23.5	-	-	46
KF32	125	25.5	160	146.2	131	93.8	40	15	60.5	42.2	23.5	-	20	59.8
KF40	150	28	150	188.5	167	103.3	40	20	69.5	51.6	26.5	120	20	60.8
KF50	175	33	180	220.2	202	121	40	23	90.5	62.3	32.5	120	40	69

Series	FA	FB	FC	FD	FT	FS	TA	TB	TE	TF	TG	TH	TJ	TK
KF16	17.7	29	16.5	-	56	19	-	-	-	-	-	-	-	-
KF25	26.5	39	24	14 G7	75	24.7	5	12.1	2.3	6.9	M5	11.5	4	32
KF32	34	53.8	34	25 G7	86.5	24.7	5	12.1	1.8	6.4	M5	11.5	4	47
KF40	42.5	56.8	41	25 G7	104	26	6	12.8	1.8	8.4	M6	17	5.5	55
KF50	52	65	50	25 G7	134	38	8	21.1	4.5	12.5	M8	23	7.5	72

**G**  
 Rodless Pneumatic Cylinders  
 OSP-P Series  
 P1X Series  
 GDL Series



For inventory, lead times, and kit lookup, visit [www.pdnplu.com](http://www.pdnplu.com)

**Mid-Section Support**

(For versions, see pages G82 to G83)

Mid-section supports are required from a certain stroke length to prevent excessive deflection and vibration of the linear drive. The diagrams show the maximum permissible unsupported length in relation to loading. A distinction must be drawn between loading 1 and loading 2.

Deflection of 0.5 mm max. between supports is permissible.

**Note:** For speeds  $v > 0.5$  m/s the distance between supports should not exceed 1 m.

**Loading 1  
Top carrier**

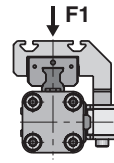

**Loading 2  
Side carrier**

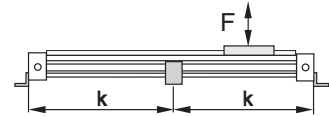
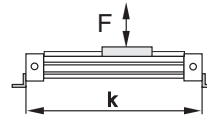
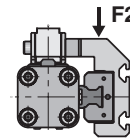

**Permissible Unsupported Length OSP-P KF16 to KF50  
Loading 1 – Top carrier**

Loading 1 – Top carrier

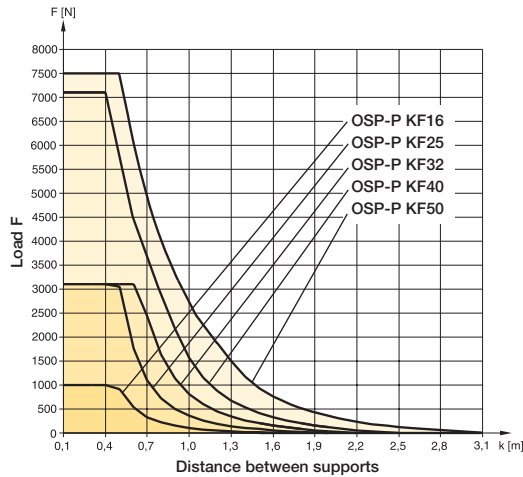

**Permissible Unsupported Length OSP-P KF16 to KF50  
Loading 2 – Side carrier**

Loading 2 – Side carrier

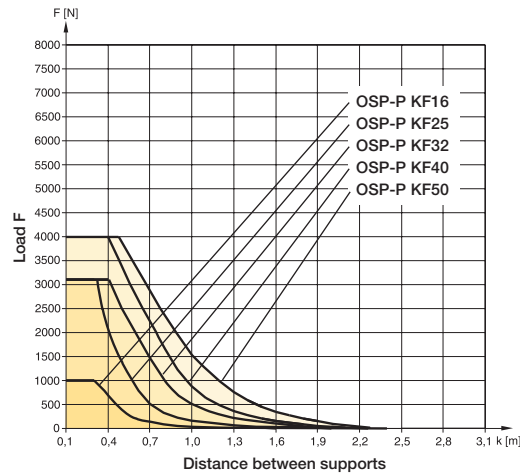

<b>G</b>	Rodless Pneumatic Cylinders
	OSP-P Series
	P1X Series
	GDL Series

**Variable Stop Type VS16 to VS50**

The variable stop Type VS provides simple stroke limitation.

It can be retrofitted and positioned anywhere along the stroke length. For every cylinder diameter two types of shock absorber are available – see “Shock Absorber Selection” below.

Mid-section supports and magnetic switches can still be fitted on the same side as the variable stop.

Depending on the application, two variable stops can be fitted if required.

**Arrangement with two variable stops**

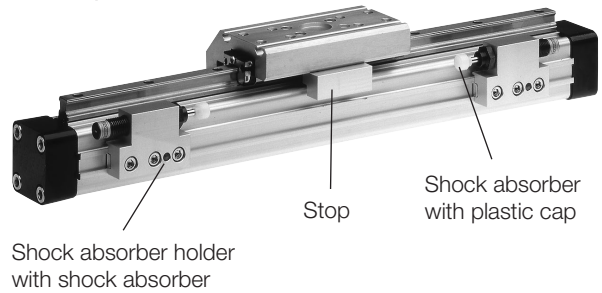

Shock absorber holder with shock absorber

**Shock Absorber Selection**

The shock absorber is selected in dependence on the mass and speed.

The mass of the carrier itself must be taken into account.

**Series OSP-KF16**

The values relate to an effective driving force of 78 N (6 bar)

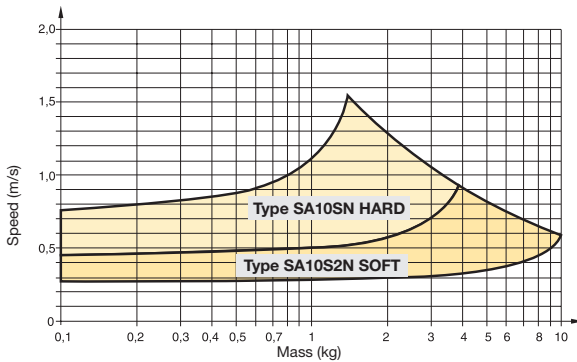

**Series OSP-KF32**

The values relate to an effective driving force of 420 N (6 bar)

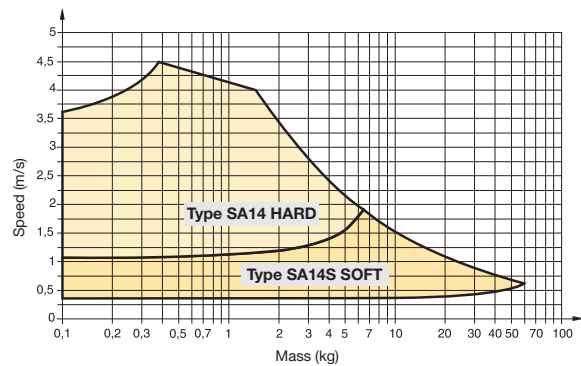

**Series OSP-KF40**

The values relate to an effective driving force of 640 N (6 bar)

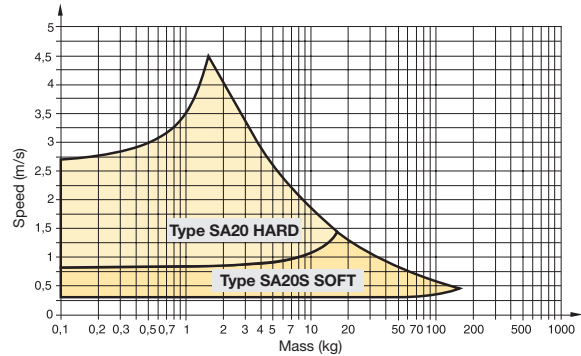

**Series OSP-KF25**

The values relate to an effective driving force of 250 N (6 bar)

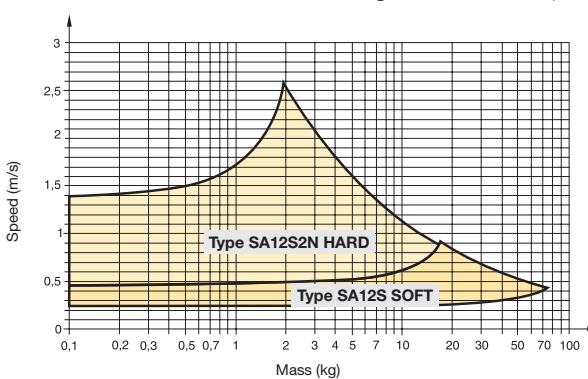

**Series OSP-KF50**

The values relate to an effective driving force of 1000 N (6 bar)

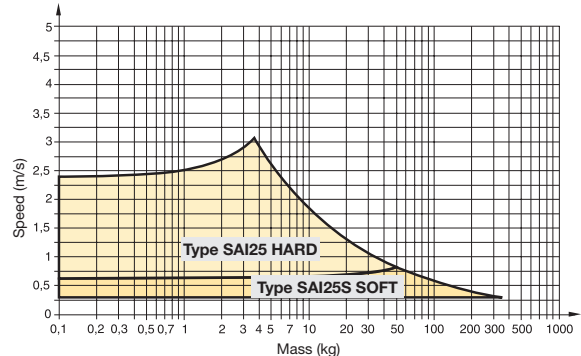

**G**  
 Rodless Pneumatic Cylinders  
 OSP-P Series  
 P1X Series  
 GDL Series



For inventory, lead times, and kit lookup, visit [www.pdnplu.com](http://www.pdnplu.com)

Ordering Information – Variable Stop Type VS16 to VS50

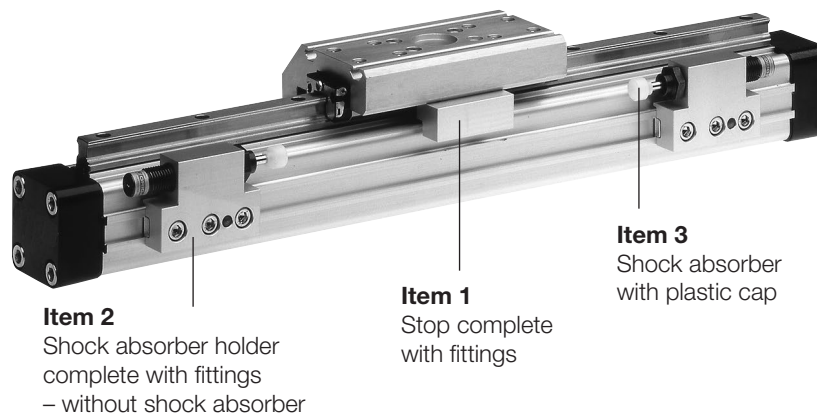

Item	Description	VS16		VS25		VS32		VS40		VS50	
		Type	Part Number	Type	Part Number	Type	Part Number	Type	Part Number	Type	Part Number
1	Stop, complete	-	21186FIL	-	21187FIL	-	21188FIL	-	21189FIL	-	21290FIL
2	Shock absorber holder, complete	-	21201FIL	-	21202FIL	-	21203FIL	-	21204FIL	-	21205FIL
3 *	Shock absorber, standard	SA10SN	MC25M	SA12S2N	MC75M-1	SA14	MC150M-B	SA20	MC225M	SAI25	MC600M
	Shock absorber, version S	SA10S2N	MC25MH	SA12S	MC75M-2	SA14S	MC150MH-B	SA20S	MC225MH	SAI25S	MC600MH

\* Shock absorber with plastic cap

Dimension – Variable Stop Type VS16 to VS50

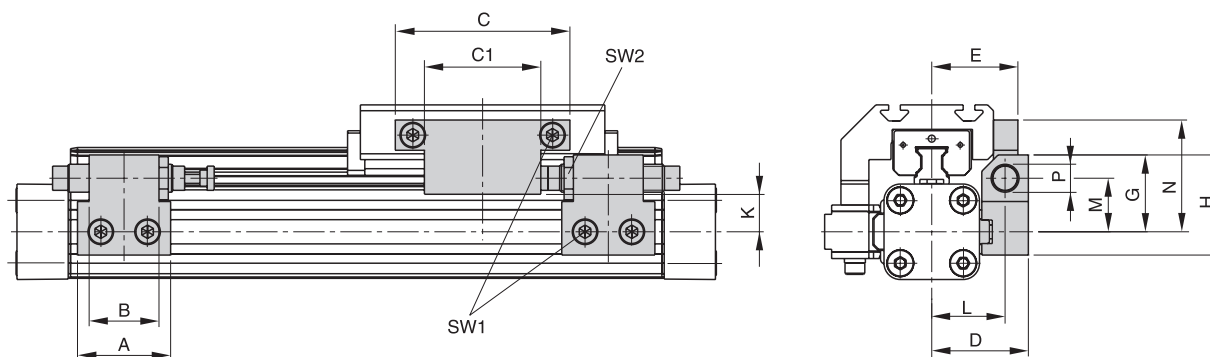

Dimension (mm) – Variable Stop Type VS16 to VS50

Series	Type	A	B	C	C1	D	E	G	H	K	L	M	N	P	SW1	SW2
OSP-KF16	VS16	30	14	50	25	33	29.7	28	38	16.2	25.5	20.5	40.5	M10 x 1	4	12.5
OSP-KF25	VS25	40	30	75	50	41.5	37	33	43	18	31.5	23	48	M12 x 1	5	16
OSP-KF32	VS32	60	40	50	-	45.5	41.5	35	45	19	35.5	25	37	M14 x 1.5	5	17
OSP-KF40	VS40	84	52	60	-	64	59	48	63	25.5	50	34	43	M20 x 1.5	5	24
OSP-KF50	VS50	84	-	60	-	75	69	55	70	26.9	57	38	58	M25 x 1.5	5	30



For inventory, lead times, and kit lookup, visit [www.pdnplu.com](http://www.pdnplu.com)

G67

Parker Hannifin Corporation  
Pneumatic Division  
Wadsworth, Ohio  
[www.parker.com/pneumatics](http://www.parker.com/pneumatics)

**G**  
 Rodless Pneumatic Cylinders  
 OSP-P Series  
 P1X Series  
 GDL Series

**Features**

**Heavy Duty Guide HD 25 to 50mm bore**

Series HD 25 to 50 for Linear-drive



- Series OSP-P

**Features**

- Guide system:
  - 4-row recirculating ball bearing guide
- Polished and hardened steel guide rail
- For highest loads in all directions
- Highest precision
- Integrated wiper system
- Integrated grease nipples
- Any lengths of stroke up to 3700 mm (longer strokes on request)
- Anodized aluminum guide carriage
  - dimensions compatible with OSP guide GUIDELINE
- Maximum speed  $v = 5 \text{ m/s}$

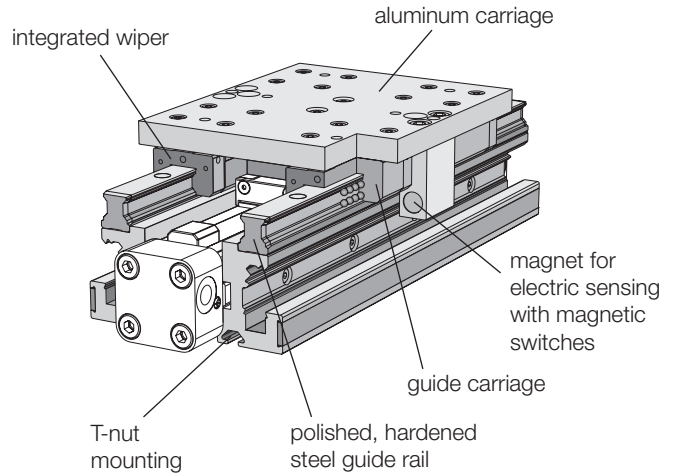
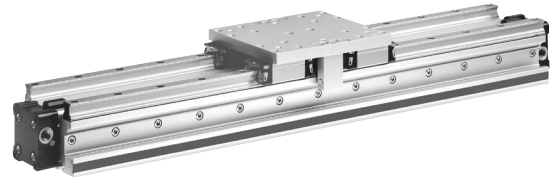

**Loads, Forces and Moments**

The table shows the maximum permissible loads. If multiple moments and forces act upon the cylinder simultaneously, the following equation applies:

$$\frac{M_x}{M_{x\max}} + \frac{M_y}{M_{y\max}} + \frac{M_z}{M_{z\max}} + \frac{F_y}{F_{y\max}} + \frac{F_z}{F_{z\max}} \leq 1$$

The sum of the loads should not exceed >1.

The table shows the maximum permissible values for light, shock-free operation which must not be exceeded even under dynamic conditions.

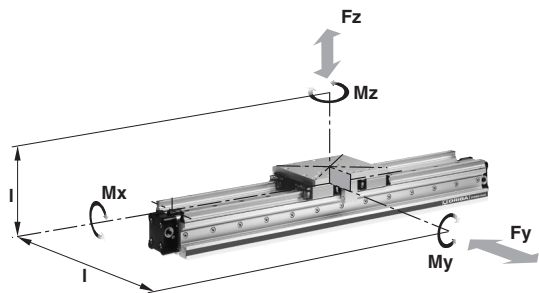

Series	For Linear Drive	Max. Moments (Nm)			Max. Loads (N)		Mass of the Linear Drive with Guide (kg)		
		Mx	My	Mz	Fz	Fy	With 0mm Stroke	Increase per 100mm Stroke	Mass * Guide Carriage (kg)
HD25	OSP-P25	260	320	320	6000	6000	3.065	0.924	1.289
HD32	OSP-P32	285	475	475	6000	6000	4.308	1.112	1.367
HD40	OSP-P40	800	1100	1100	15000	15000	7.901	1.748	2.712
HD50	OSP-P50	1100	1400	1400	18000	18000	11.648	2.180	3.551

\*Add the mass of the guide carriage to the mass to be cushioned.

**G**  
 Rodless Pneumatic Cylinders  
 OSP-P Series  
 P1X Series  
 GDL Series



For inventory, lead times, and kit lookup, visit [www.pdnplu.com](http://www.pdnplu.com)

Ordering information for OSP-P rodless HD pneumatic series

1-4	5-6	7	8	9	10	11	12-16	17	18	19	20	21	22	23	24	25
<b>OSP</b>	<b>P</b>	<b>25</b>	<b>0</b>	<b>1</b>	<b>0</b>	<b>0</b>	<b>01100</b>	<b>0</b>	<b>0</b>	<b>0</b>	<b>D</b>	<b>0</b>	<b>0</b>	<b>1</b>	<b>0</b>	<b>0</b>

<table border="1" style="width:100%; border-collapse: collapse;"> <tr><td colspan="2"><b>Bore</b></td></tr> <tr><td style="width:50%;">25</td><td style="width:50%;">32</td></tr> <tr><td>40</td><td>50</td></tr> </table> <table border="1" style="width:100%; border-collapse: collapse;"> <tr><td colspan="2"><b>Piston Style</b></td></tr> <tr><td style="width:50%;">0 Standard</td><td style="width:50%;">1 Tandem</td></tr> </table> <table border="1" style="width:100%; border-collapse: collapse;"> <tr><td colspan="2"><b>Seals</b></td></tr> <tr><td style="width:50%;">0 Standard</td><td style="width:50%;">1 Fluorocarbon</td></tr> </table> <table border="1" style="width:100%; border-collapse: collapse;"> <tr><td colspan="2"><b>Hardware</b></td></tr> <tr><td style="width:50%;">0 Standard</td><td style="width:50%;"></td></tr> </table> <table border="1" style="width:100%; border-collapse: collapse;"> <tr><td colspan="2"><b>Porting Configurations</b></td></tr> <tr><td style="width:50%;">0 Standard</td><td style="width:50%;">1 End Face (25,32,40,50)</td></tr> <tr><td>2 Single End Porting (25,32,40,50)</td><td>3 Left Std Pos #2, Right Pos #5 (25,32,40,50)</td></tr> <tr><td>4 Left Pos #5, Right Std Pos #2 (25,32,40,50)</td><td>6 Single End Porting at #5 (50)</td></tr> <tr><td>A 24VDC VOE Valves (25,32,40,50)</td><td>B 220VAC VOE Valves (25,32,40,50)</td></tr> <tr><td>C 48VDC VOE Valves (25,32,40,50)</td><td>E 110VAC VOE Valves (25,32,40,50)</td></tr> </table> <p>Note: Single end porting on 16mm bore, then end caps cannot be rotated.</p>	<b>Bore</b>		25	32	40	50	<b>Piston Style</b>		0 Standard	1 Tandem	<b>Seals</b>		0 Standard	1 Fluorocarbon	<b>Hardware</b>		0 Standard		<b>Porting Configurations</b>		0 Standard	1 End Face (25,32,40,50)	2 Single End Porting (25,32,40,50)	3 Left Std Pos #2, Right Pos #5 (25,32,40,50)	4 Left Pos #5, Right Std Pos #2 (25,32,40,50)	6 Single End Porting at #5 (50)	A 24VDC VOE Valves (25,32,40,50)	B 220VAC VOE Valves (25,32,40,50)	C 48VDC VOE Valves (25,32,40,50)	E 110VAC VOE Valves (25,32,40,50)	<table border="1" style="width:100%; border-collapse: collapse;"> <tr><td colspan="2"><b>Lubrication</b></td></tr> <tr><td style="width:50%;">0 Standard</td><td style="width:50%;"></td></tr> </table> <table border="1" style="width:100%; border-collapse: collapse;"> <tr><td colspan="2"><b>Stroke</b></td></tr> <tr><td style="width:50%;">x</td><td style="width:50%;">x</td></tr> <tr><td>x</td><td>x</td></tr> <tr><td>x</td><td>x</td></tr> <tr><td>x</td><td>x</td></tr> </table> <p>5 digits in whole millimeters (ex. 1100mm = 01100)</p> <table border="1" style="width:100%; border-collapse: collapse;"> <tr><td colspan="2"><b>Piston Mounting</b></td></tr> <tr><td style="width:50%;">0 None</td><td style="width:50%;"></td></tr> </table> <table border="1" style="width:100%; border-collapse: collapse;"> <tr><td colspan="2"><b>Cushions / Stops</b></td></tr> <tr><td style="width:50%;">0 Standard</td><td style="width:50%;">1 Long Cushions (25,32,40)</td></tr> <tr><td>2 VS Soft Left</td><td>3 VS Hard Left</td></tr> <tr><td>4 VS Soft Right</td><td>5 VS Hard Right</td></tr> <tr><td>6 VS Soft Both Sides</td><td>7 VS Hard Both Sides</td></tr> </table> <table border="1" style="width:100%; border-collapse: collapse;"> <tr><td colspan="2"><b>Guides / Brakes</b></td></tr> <tr><td style="width:50%;">D Heavy Duty</td><td style="width:50%;"></td></tr> </table> <table border="1" style="width:100%; border-collapse: collapse;"> <tr><td colspan="2"><b>Endcap Position</b></td></tr> <tr><td style="width:50%;">0 Both Pos #2</td><td style="width:50%;">1 Both Pos #3</td></tr> <tr><td>2 Both Pos #4</td><td>3 Both Pos #1</td></tr> <tr><td>4 Left #3 / Right #2</td><td>5 Left #4 / Right #2</td></tr> <tr><td>6 Left #1 / Right #2</td><td>7 Left #2 / Right #3</td></tr> <tr><td>8 Left #4 / Right #3</td><td>9 Left #1 / Right #3</td></tr> <tr><td>A Left #2 / Right #4</td><td>B Left #3 / Right #4</td></tr> <tr><td>C Left #1 / Right #4</td><td>D Left #2 / Right #1</td></tr> <tr><td>E Left #3 / Right #1</td><td>F Left #4 / Right #1</td></tr> </table>	<b>Lubrication</b>		0 Standard		<b>Stroke</b>		x	x	x	x	x	x	x	x	<b>Piston Mounting</b>		0 None		<b>Cushions / Stops</b>		0 Standard	1 Long Cushions (25,32,40)	2 VS Soft Left	3 VS Hard Left	4 VS Soft Right	5 VS Hard Right	6 VS Soft Both Sides	7 VS Hard Both Sides	<b>Guides / Brakes</b>		D Heavy Duty		<b>Endcap Position</b>		0 Both Pos #2	1 Both Pos #3	2 Both Pos #4	3 Both Pos #1	4 Left #3 / Right #2	5 Left #4 / Right #2	6 Left #1 / Right #2	7 Left #2 / Right #3	8 Left #4 / Right #3	9 Left #1 / Right #3	A Left #2 / Right #4	B Left #3 / Right #4	C Left #1 / Right #4	D Left #2 / Right #1	E Left #3 / Right #1	F Left #4 / Right #1	<table border="1" style="width:100%; border-collapse: collapse;"> <tr><td colspan="2"><b>Dovetail Cover</b></td></tr> <tr><td style="width:50%;">0 Standard</td><td style="width:50%;">X Without Cover Rail</td></tr> </table> <table border="1" style="width:100%; border-collapse: collapse;"> <tr><td colspan="2"><b>Version</b></td></tr> <tr><td style="width:50%;">0 Standard</td><td style="width:50%;"></td></tr> </table> <table border="1" style="width:100%; border-collapse: collapse;"> <tr><td colspan="2"><b>Endcap Mounting</b></td></tr> <tr><td style="width:50%;">0 None</td><td style="width:50%;"></td></tr> </table> <table border="1" style="width:100%; border-collapse: collapse;"> <tr><td colspan="2"><b>Switches</b> †</td></tr> <tr><td style="width:50%;">0 None</td><td style="width:50%;">1 Normally Open Reed Switch (25 thru 50)</td></tr> <tr><td>2 Normally Closed Reed Switch (25 thru 50)</td><td>3 PNP Hall Sensor w/Extension Cables (25 thru 50)</td></tr> <tr><td>4 NPN Hall Sensor w/Extension Cables (25 thru 50)</td><td></td></tr> </table> <p>† Note: 2 switches will be supplied. For different quantity, please order as a separate line item.</p>	<b>Dovetail Cover</b>		0 Standard	X Without Cover Rail	<b>Version</b>		0 Standard		<b>Endcap Mounting</b>		0 None		<b>Switches</b> †		0 None	1 Normally Open Reed Switch (25 thru 50)	2 Normally Closed Reed Switch (25 thru 50)	3 PNP Hall Sensor w/Extension Cables (25 thru 50)	4 NPN Hall Sensor w/Extension Cables (25 thru 50)	
<b>Bore</b>																																																																																																						
25	32																																																																																																					
40	50																																																																																																					
<b>Piston Style</b>																																																																																																						
0 Standard	1 Tandem																																																																																																					
<b>Seals</b>																																																																																																						
0 Standard	1 Fluorocarbon																																																																																																					
<b>Hardware</b>																																																																																																						
0 Standard																																																																																																						
<b>Porting Configurations</b>																																																																																																						
0 Standard	1 End Face (25,32,40,50)																																																																																																					
2 Single End Porting (25,32,40,50)	3 Left Std Pos #2, Right Pos #5 (25,32,40,50)																																																																																																					
4 Left Pos #5, Right Std Pos #2 (25,32,40,50)	6 Single End Porting at #5 (50)																																																																																																					
A 24VDC VOE Valves (25,32,40,50)	B 220VAC VOE Valves (25,32,40,50)																																																																																																					
C 48VDC VOE Valves (25,32,40,50)	E 110VAC VOE Valves (25,32,40,50)																																																																																																					
<b>Lubrication</b>																																																																																																						
0 Standard																																																																																																						
<b>Stroke</b>																																																																																																						
x	x																																																																																																					
x	x																																																																																																					
x	x																																																																																																					
x	x																																																																																																					
<b>Piston Mounting</b>																																																																																																						
0 None																																																																																																						
<b>Cushions / Stops</b>																																																																																																						
0 Standard	1 Long Cushions (25,32,40)																																																																																																					
2 VS Soft Left	3 VS Hard Left																																																																																																					
4 VS Soft Right	5 VS Hard Right																																																																																																					
6 VS Soft Both Sides	7 VS Hard Both Sides																																																																																																					
<b>Guides / Brakes</b>																																																																																																						
D Heavy Duty																																																																																																						
<b>Endcap Position</b>																																																																																																						
0 Both Pos #2	1 Both Pos #3																																																																																																					
2 Both Pos #4	3 Both Pos #1																																																																																																					
4 Left #3 / Right #2	5 Left #4 / Right #2																																																																																																					
6 Left #1 / Right #2	7 Left #2 / Right #3																																																																																																					
8 Left #4 / Right #3	9 Left #1 / Right #3																																																																																																					
A Left #2 / Right #4	B Left #3 / Right #4																																																																																																					
C Left #1 / Right #4	D Left #2 / Right #1																																																																																																					
E Left #3 / Right #1	F Left #4 / Right #1																																																																																																					
<b>Dovetail Cover</b>																																																																																																						
0 Standard	X Without Cover Rail																																																																																																					
<b>Version</b>																																																																																																						
0 Standard																																																																																																						
<b>Endcap Mounting</b>																																																																																																						
0 None																																																																																																						
<b>Switches</b> †																																																																																																						
0 None	1 Normally Open Reed Switch (25 thru 50)																																																																																																					
2 Normally Closed Reed Switch (25 thru 50)	3 PNP Hall Sensor w/Extension Cables (25 thru 50)																																																																																																					
4 NPN Hall Sensor w/Extension Cables (25 thru 50)																																																																																																						



Note: Position #2 is the standard location.

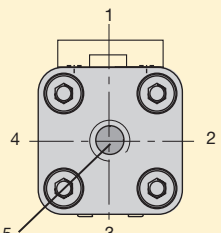

For inventory, lead times, and kit lookup, visit [www.pdnplu.com](http://www.pdnplu.com)

G69

Parker Hannifin Corporation  
Pneumatic Division  
Wadsworth, Ohio  
[www.parker.com/pneumatics](http://www.parker.com/pneumatics)

G

Rodless Pneumatic Cylinders

---

OSP-P Series

---

P1X Series

---

GDL Series



**Series OSP-P HD 25 to 50mm**

**Note:** The HD heavy duty guide must be mounted on a flat surface for its entire length.

If T-grooves or T-bolts are used, the distance between them should not exceed 100 mm.

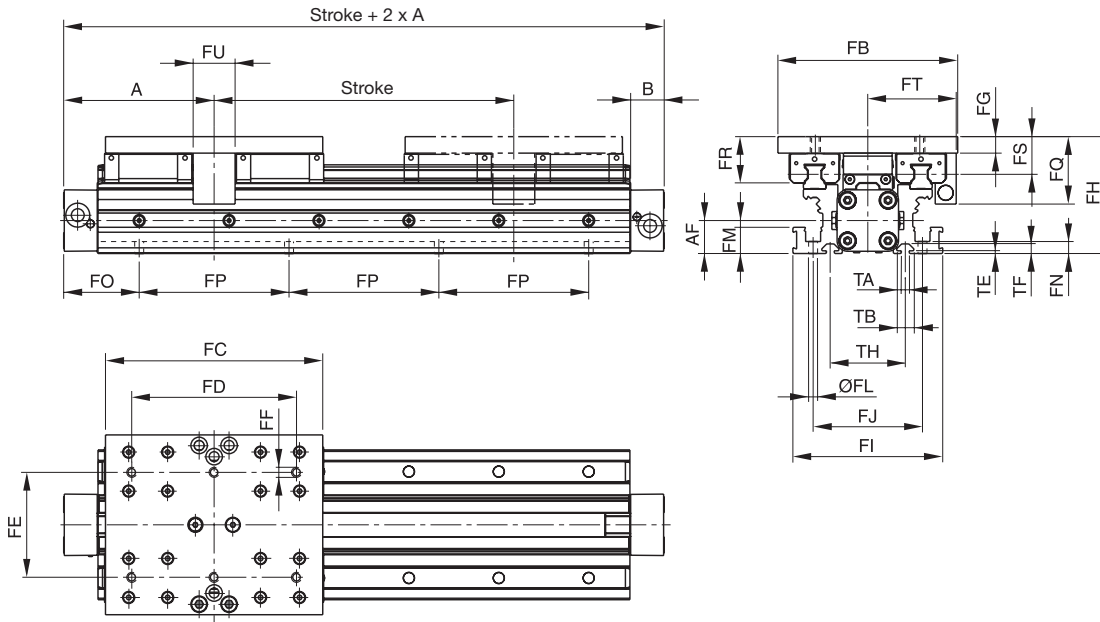

**G**  
 Rodless Pneumatic  
 Cylinders  
 OSP-P  
 Series  
 P1X  
 Series  
 GDL  
 Series

**Variable Stop  
 Type VS25 to VS50**

The variable stop provides simple stroke limitation and can be supplied mounted on the right or left, as required.

For further information see Variable Stop page G75.

For shock absorber selection see page G62.

**Incremental displacement  
 measuring system  
 Sensoflex**

Series SFI-plus can be supplied mounted on the right or left, as required.

For further information see page G87.

**Arrangement of magnetic  
 switches:**

Magnetic switches can be fitted anywhere on either side.

For further information see following data sheets:

Magnetic Switches see pages G161-G170.

Dovetail Cover see page G85.

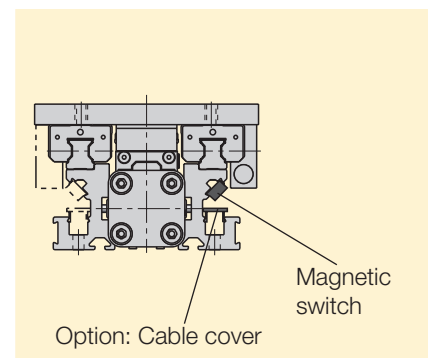
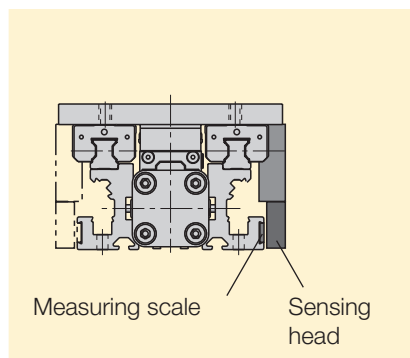
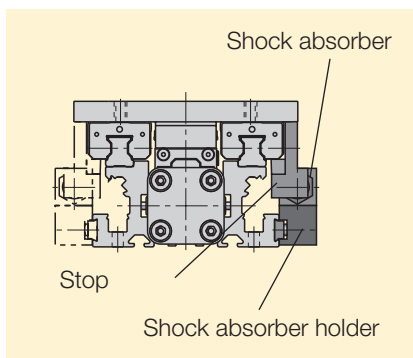

For inventory, lead times, and kit lookup, visit [www.pdnplu.com](http://www.pdnplu.com)



Series	A	B	AF	FB	FC	FD	FE	FF	FG	FH	FI	FJ	ØFL
HD25	100	22	22	120	145	110	70	M6	11	78	100	73	6
HD32	125	25.5	30	120	170	140	80	M6	11	86	112	85	6
HD40	150	28	38	160	180	140	110	M8	14	108	132	104	7.5
HD50	175	33	48	180	200	160	120	M8	14	118	150	118	7.5

Series	FM	FN	FP	FQ	FR	FS	FT	FU	TA	TB	TE	TF	TH
HD25	17.5	8	100	45	31	25	59	28	5.2	11.5	1.8	6.4	50
HD32	17.5	8	100	45	31	25	63	30	5.2	11.5	1.8	6.4	60
HD40	22	10	100	58	40	31.5	76	30	8.2	20	4.5	12.3	66
HD50	22	10	100	58	44	35.5	89	30	8.2	20	4.5	12.3	76

**Note:**

The dimension FO is derived from the last two digits of the stroke:

For a cylinder OSP-P25 the adjacent table indicates that for x = 25 mm:

FO = 62.5 mm

**Example:**

Stroke 1525 mm



FO OSP-P					FO OSP-P					FO OSP-P				
X	HD25	HD32	HD40	HD50	X	HD25	HD32	HD40	HD50	X	HD25	HD32	HD40	HD50
00	50.0	75.0	50.0	75.0	34	67.0	42.0	67.0	92.0	68	34.0	59.0	84.0	59.0
01	50.5	75.5	50.5	75.5	35	67.5	42.5	67.5	92.5	69	34.5	59.5	84.5	59.5
02	51.0	76.0	51.0	76.0	36	68.0	43.0	68.0	93.0	70	35.0	60.0	85.0	60.0
03	51.5	76.5	51.5	76.5	37	68.5	43.5	68.5	93.5	71	35.5	60.5	85.5	60.5
04	52.0	77.0	52.0	77.0	38	69.0	44.0	69.0	94.0	72	36.0	61.0	86.0	61.0
05	52.5	77.5	52.5	77.5	39	69.5	44.5	69.5	94.5	73	36.5	61.5	86.5	61.5
06	53.0	78.0	53.0	78.0	40	70.0	45.0	70.0	95.0	74	37.0	62.0	87.0	62.0
07	53.5	78.5	53.5	78.5	41	70.5	45.5	70.5	95.5	75	37.5	62.5	87.5	62.5
08	54.0	79.0	54.0	79.0	42	71.0	46.0	71.0	96.0	76	38.0	63.0	88.0	63.0
09	54.5	79.5	54.5	79.5	43	71.5	46.5	71.5	96.5	77	38.5	63.5	88.5	63.5
10	55.0	80.0	55.0	80.0	44	72.0	47.0	72.0	97.0	78	39.0	64.0	89.0	64.0
11	55.5	80.5	55.5	80.5	45	72.5	47.5	72.5	97.5	79	39.5	64.5	89.5	64.5
12	56.0	81.0	56.0	81.0	46	73.0	48.0	73.0	98.0	80	40.0	65.0	90.0	65.0
13	56.5	81.5	56.5	81.5	47	73.5	48.5	73.5	98.5	81	40.5	65.5	90.5	65.5
14	57.0	82.0	57.0	82.0	48	74.0	49.0	74.0	99.0	82	41.0	66.0	91.0	66.0
15	57.5	82.5	57.5	82.5	49	74.5	49.5	74.5	99.5	83	41.5	66.5	91.5	66.5
16	58.0	83.0	58.0	83.0	50	75.0	50.0	75.0	100.0	84	42.0	67.0	92.0	67.0
17	58.5	83.5	58.5	83.5	51	75.5	50.5	75.5	100.5	85	42.5	67.5	92.5	67.5
18	59.0	84.0	59.0	84.0	52	76.0	51.0	76.0	101.0	86	43.0	68.0	93.0	68.0
19	59.5	84.5	59.5	84.5	53	76.5	51.5	76.5	101.5	87	43.5	68.5	93.5	68.5
20	60.0	85.0	60.0	85.0	54	77.0	52.0	77.0	102.0	88	44.0	69.0	94.0	69.0
21	60.5	85.5	60.5	85.5	55	77.5	52.5	77.5	102.5	89	44.5	69.5	94.5	69.5
22	61.0	86.0	61.0	86.0	56	78.0	53.0	78.0	103.0	90	45.0	70.0	95.0	70.0
23	61.5	86.5	61.5	86.5	57	78.5	53.5	78.5	103.5	91	45.5	70.5	95.5	70.5
24	62.0	87.0	62.0	87.0	58	79.0	54.0	79.0	104.0	92	46.0	71.0	96.0	71.0
25	62.5	87.5	62.5	87.5	59	79.5	54.5	79.5	104.5	93	46.5	71.5	96.5	71.5
26	63.0	88.0	63.0	88.0	60	80.0	55.0	80.0	105.0	94	47.0	72.0	97.0	72.0
27	63.5	88.5	63.5	88.5	61	80.5	55.5	80.5	105.5	95	47.5	72.5	97.5	72.5
28	64.0	89.0	64.0	89.0	62	81.0	56.0	81.0	106.0	96	48.0	73.0	98.0	73.0
29	64.5	89.5	64.5	89.5	63	81.5	56.5	81.5	106.5	97	48.5	73.5	98.5	73.5
30	65.0	90.0	65.0	90.0	64	82.0	57.0	82.0	107.0	98	49.0	74.0	99.0	74.0
31	65.5	90.5	65.5	90.5	65	82.5	57.5	82.5	107.5	99	49.5	74.5	99.5	74.5
32	66.0	91.0	66.0	91.0	66	83.0	58.0	83.0	108.0					
33	66.5	91.5	66.5	91.5	67	83.5	58.5	83.5	108.5					

  
**Rodless Pneumatic Cylinders**  
 OSP-P Series  
 P1X Series  
 GDL Series



For inventory, lead times, and kit lookup, visit [www.pdnplu.com](http://www.pdnplu.com)

Ordering Information – Variable Stop Type VS25 to VS50

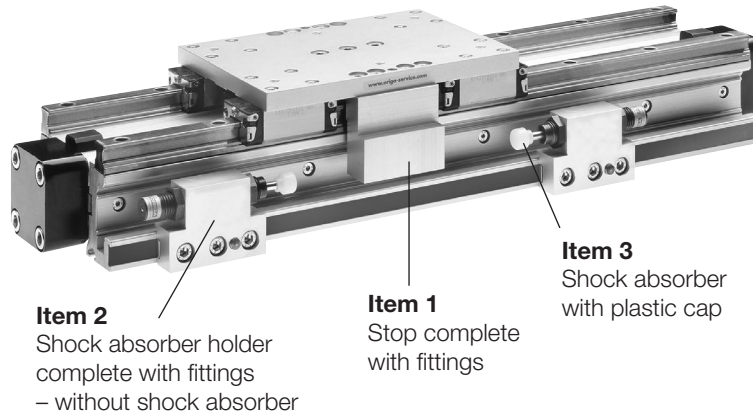

Item	Description	Size VS25		Size VS32		Size VS40		Size VS50	
		Type	Part Number	Type	Part Number	Type	Part Number	Type	Part Number
1	Stop, complete	–	21257FIL	–	21158FIL	–	21159FIL	–	21260FIL
2	Shock absorber holder, complete	–	21202FIL	–	21203FIL	–	21204FIL	–	21205FIL
3 *	Shock absorber, standard	SA12	MC75M-1	SA14	MC150M-B	SA20	MC225M	SAI25	MC600M
	Shock absorber, version S	SA12S	MC75M-2	SA14S	MC150MH-B	SA20S	MC225MH	SAI25S	MC600MH

\* Shock absorber with plastic cap

Dimension – Variable Stop Type VS16 to VS50

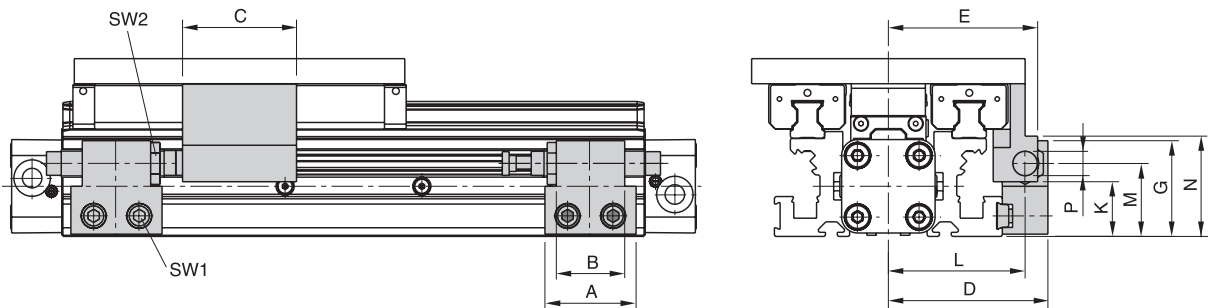

Series	Type	A	B	C	D	E	G	K	L	M	N	P	SW1	SW2
OSP-HD25	VS25	40	30	50	70	65.5	42	26	60	32	42	M12 x 1	5	16
OSP-HD32	VS32	60	40	54	73	71	44	28	63	34	53	M14 x 1.5	5	17
OSP-HD40	VS40	84	52	55	96	92	59	35	82	45	61	M20 x 1.5	5	24
OSP-HD50	VS50	84	-	60	107	105	66	37	89	49	66	M25 x 1.5	5	30

Shock Absorber Selection

For shock absorber selection in dependence on mass and speed see page G68.

**G**  
 Rodless Pneumatic Cylinders  
 OSP-P Series  
 P1X Series  
 GDL Series



For inventory, lead times, and kit lookup, visit [www.pdnplu.com](http://www.pdnplu.com)

**Intermediate Stop Module – 25mm only**

The intermediate stop module ZSM allows the guide carriage to stop at any desired intermediate positions with high accuracy. It can be retrofitted. Depending on the application, i.e. the number of intermediate stops, one or more intermediate position stops can be used.

The intermediate position stops can be retracted and extended without the need for the guide carriage to be moved back out of position.

Therefore the guide carriage can be made to stop at the defined intermediate positions in any order.

**Intermediate stop module ZSM:**

- Allows stopping at any intermediate positions
- Intermediate position stops can be located steplessly anywhere along the whole stroke length
- Movement to the next position without reverse stroke
- Compact unit
- Cost-effective positioning module without electrical or electronic components
- Option: end stop with fine adjustment

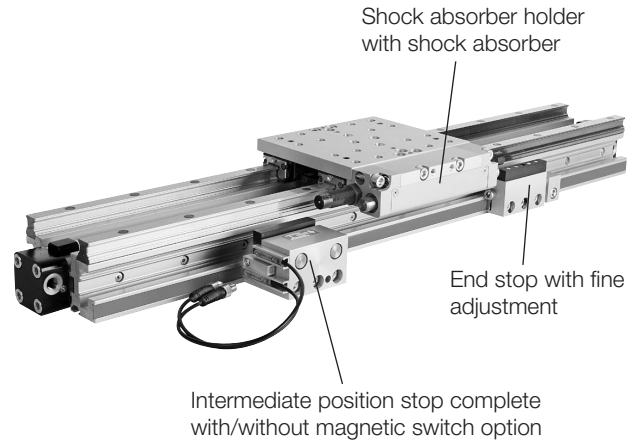

**Operating information**

Operating pressure:	87 to 116 PSIG (4 to 8 bar)
Temperature range:	14°F to 158°F (-10°C to 70°C)
Intermediate position grid:	85mm

**Shock Absorber**

**Type SA14S**

The values relate to an effective driving force of 250 N (6 bar)

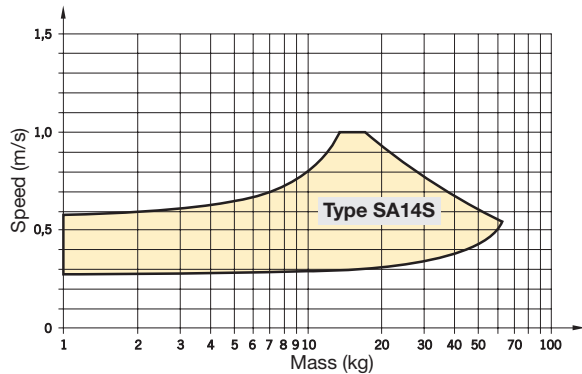

**Intermediate Stop Module – Type ZSM..HD**

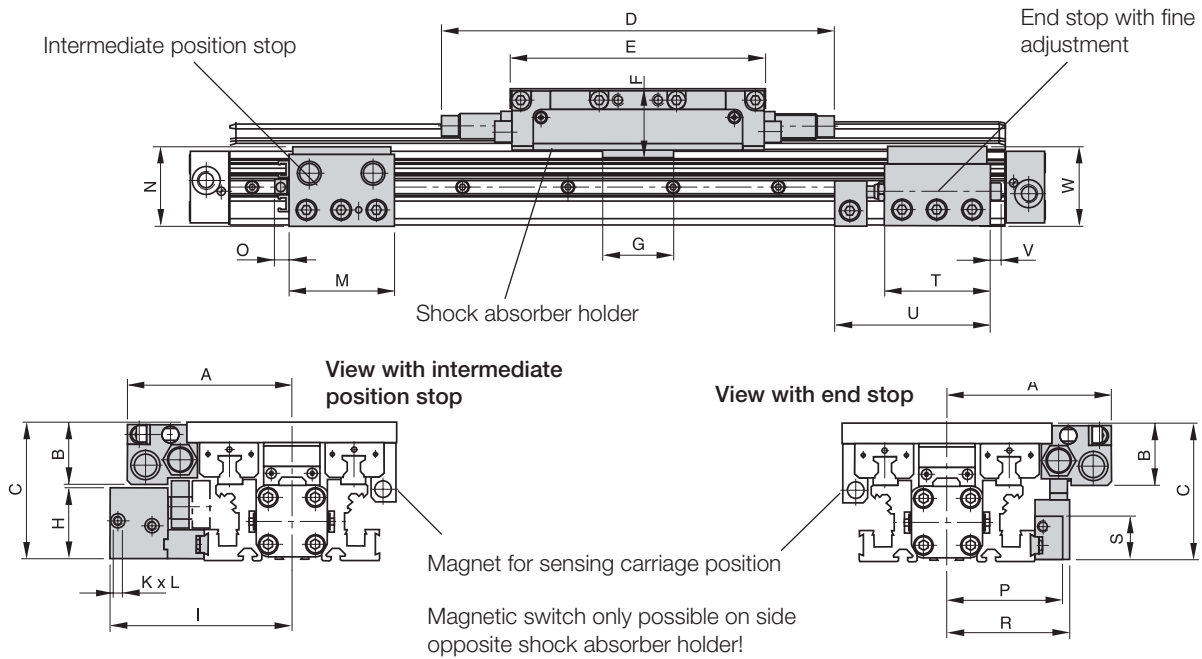

**Dimension (mm)**

Series	A	B	C	D	E	F	G	H	I	K	L	M	N	O	P	R	S	T	U	V	W
ZSM25	94	35	78	224	145	39	40	41	104	M5	5	60	45	8	66	70	26	60	93	6	45

**Shock Absorber Arrangement in Dependence on Direction of Movement**

**From right to left**

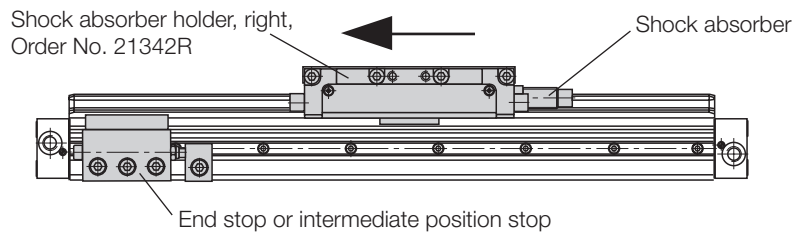

**In both directions**

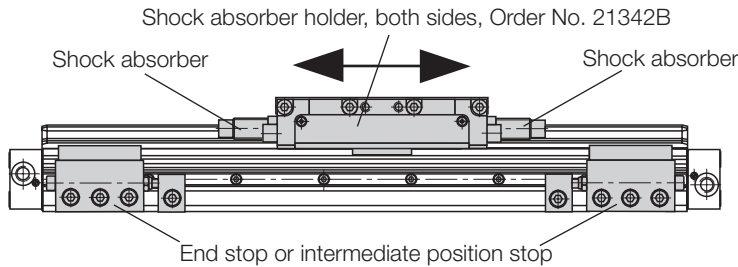

**From left to right**

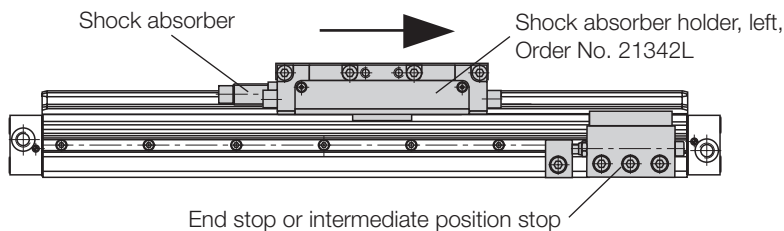

**G**  
 Rodless Pneumatic Cylinders  
 OSP-P Series  
 P1X Series  
 GDL Series



For inventory, lead times, and kit lookup, visit [www.pdnplu.com](http://www.pdnplu.com)

**Order Instructions – intermediate Stop Module Type ZSM..HD**

Illustration shows version with shock absorber holder for movement in both directions and magnetic switch option with T-slot switches.

**Note:** For movement onwards from the intermediate position, the intermediate position stop must advance.

The intermediate position stop can only advance if both cylinder chambers of the OSP-P cylinder are pressurized.

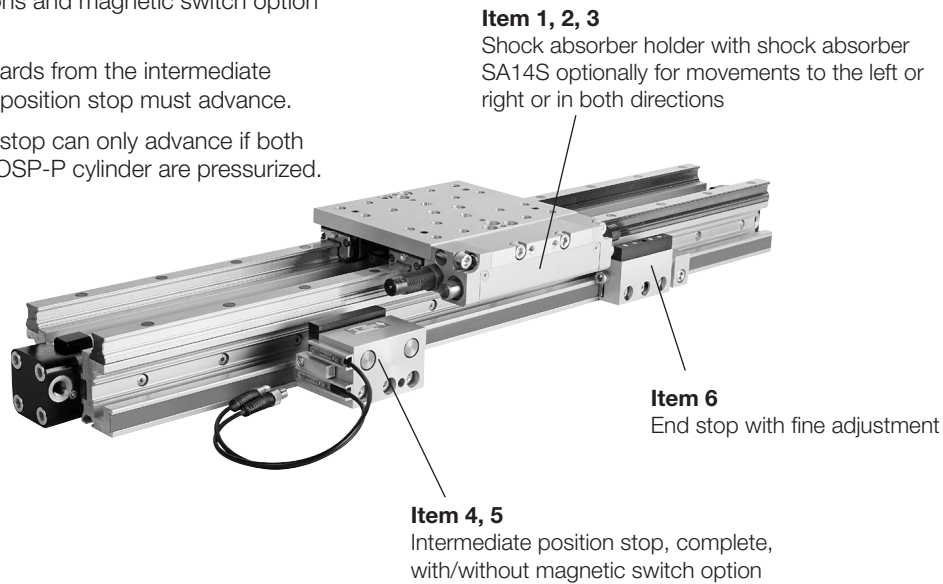

**Item 1, 2, 3**  
Shock absorber holder with shock absorber SA14S optionally for movements to the left or right or in both directions

**Item 6**  
End stop with fine adjustment

**Item 4, 5**  
Intermediate position stop, complete, with/without magnetic switch option

**Order instructions – intermediate stop module Type ZSM..HD 25mm Only**

For Intermediate Stop Module	Item	Description	Part Number
ZSM25HD	1*	Shock absorber holder with shock absorber SA14S, both sides	21342BFIL
ZSM25HD	2*	Shock absorber holder with shock absorber SA14S, left	21342LFIL
ZSM25HD	3*	Shock absorber holder with shock absorber SA14S, right	21342RFIL
ZSM25HD	4	Intermediate position stop complete, without magnetic switch option	21343FIL
ZSM25HD	5	Intermediate position stop complete, with magnetic switch option	21344FIL
ZSM25HD	6	End stop with fine adjustment	21346FIL

\* The shock absorbers are installed in the shock absorber holder and adjusted in our workshop.

**G**

**Rodless Pneumatic Cylinders**

---

**OSP-P Series**

---

**P1X Series**

---

**GDL Series**

**Overview**



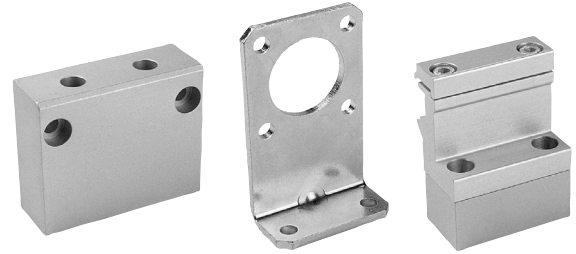

**Mountings for Linear Drives fitted with OSP-Guides**

For Linear-drive

- Series OSP-P



Type – OSP Guides

Mounting Type	Type	SLIDELINE PROLINE MULTIBRAKE						POWERSLIDE										
		16†	25	32	40	50	63†	80†	16/ 25	25/ 25	25/ 35	25/ 44	32/ 35	32/ 44	40/ 44	40/ 60	50/ 60	50/ 76
 End cap mounting	Type A1	X							X									
	Type A2	O	O	O														
	Type A3									O	O		O					
 End cap mounting, reinforced	Type B1		X	X						X	X	X	X	X				
	Type B3								O									
	Type B4											O		O				
	Type B5																	
 End cap mounting	Type C1				X	X	X	X						X	X	X	X	
	Type C2				O	O												
	Type C3						O	O						O		O		
	Type C4														O		O	
 Mid-Section support, small Mid-Section support, wide	Type D1	X	X	X	X	X	X	X	X	X	X	X	X	X	X	X	X	
	Type E1	X	X	X	X	X	X	X	X	X	X	X	X	X	X	X	X	
	Type E2	O	O	O	O	O												
	Type E3						O	O	O	O	O		O		O		O	
	Type E4											O		O		O		
Type E5																		

- X** = carriage mounted in top (12 o'clock position)
- O** = carriage mounted in lateral (3 or 9 o'clock position)
-  = available components
- †** = not available for all sizes

**G**  
 Rodless Pneumatic  
 Cylinders  
 OSP-P  
 Series  
 P1X  
 Series  
 GDL  
 Series



For inventory, lead times, and kit lookup, visit [www.pdnplu.com](http://www.pdnplu.com)

**End Cap Mountings**

Four internal screw threads are located in the end faces of all OSP actuators for mounting the drive unit. End cap mountings may be secured across any two adjacent screws.

**Material:**

- Series OSP-16, 25, 32: Galvanized steel
- Series OSP-40, 50, 63, 80: Anodized aluminum

The mountings are supplied in pairs.

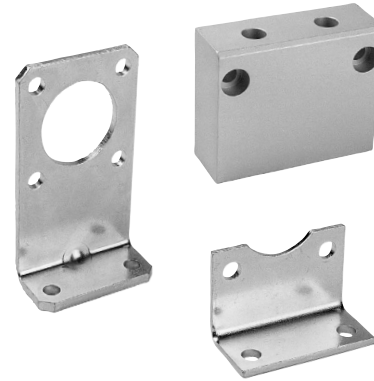

**Dimension (mm)**

**AE and AF (Dependent on the mounting type)**

Mount. Type	Dimensions AE for Size								AF for Size							
	16	25	32	40	50	63	80	16	25	32	40	50	63	80		
A1	12.5	18	20	-	-	-	-	15	22	30	-	-	-	-		
A2	27.5	33	34	-	-	-	-	30	37	44	-	-	-	-		
A3	-	45	42	-	-	-	-	49	52	-	-	-	-	-		
B1	-	42	55	-	-	-	-	22	30	-	-	-	-	-		
B3	55	-	-	-	-	-	-	42	-	-	-	-	-	-		
B4	-	80	85	-	-	-	-	60	60	-	-	-	-	-		
B5	-	-	90	-	-	-	-	65	-	-	-	-	-	-		
C1	-	-	-	24	30	40	50	-	-	-	38	48	57	72		
C2	-	-	-	37	39	-	-	-	-	-	51	57	-	-		
C3	-	-	-	46	54	76	88	-	-	-	60	72	93	110		
C4	-	-	-	56	77	-	-	-	-	-	70	95	-	-		

Series	E	øU	AB	AC	AD	CL	DG
OSP-P16	18	3.6	18	10	14	1.6	26
OSP-P25	27	5.8	27	16	22	2.5	39
OSP-P32	36	6.6	36	18	26	3	50
OSP-P40	54	9	30	12.5	24	-	68
OSP-P50	70	9	40	12.5	24	-	86
OSP-P63	78	11	48	15	30	-	104
OSP-P80	96	14	60	17.5	35	-	130

**Series OSP-P16, 25, 32: Type A**

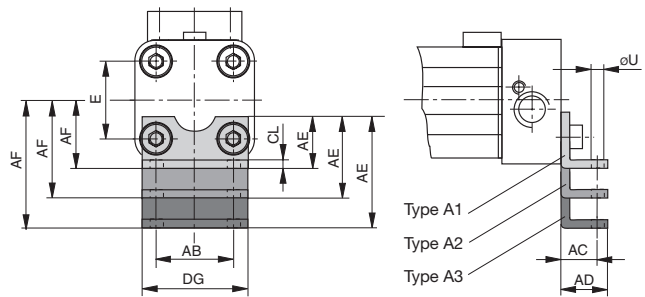

**Series OSP-P16, 25, 32: Type B**

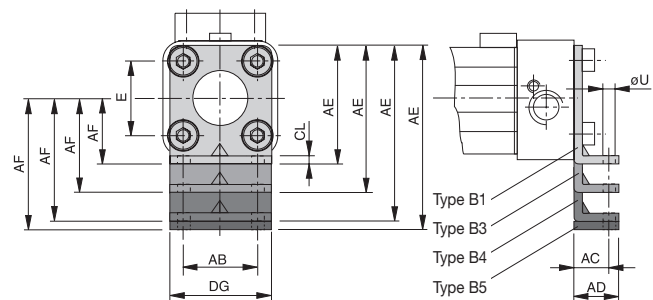

**Series OSP-P40, 50, 63, 80: Type C**

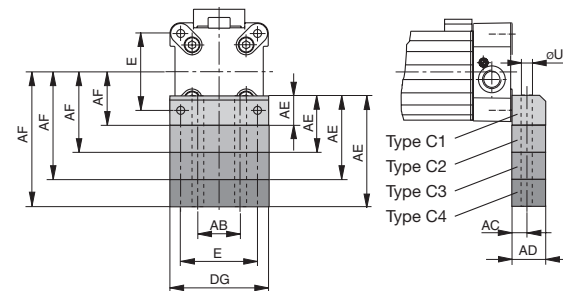

Rodless Pneumatic Cylinders

OSP-P Series

P1X Series

GDL Series



For inventory, lead times, and kit lookup, visit [www.pdnplu.com](http://www.pdnplu.com)

**End Cap Mountings – Type B Ø 16 to 32mm**

For Linear-drive with Recirculating Ball Bearing Guide

- Series OSP-P STL
- Series OSP-P KF

**Material:**

- Galvanized steel
- Anodized aluminum

The mountings are supplied in pairs.  
Drawing shows: Mounting with Guide Type STL



**Type B1: 16, 25, 32mm**  
Series OSP-P STL and KF

Installation: Top carrier  
Side piston

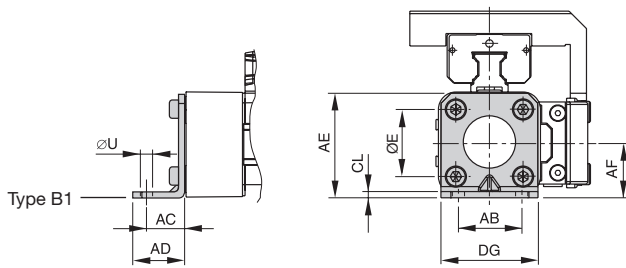

**Type B3: 16, 25mm**  
**Type B5: 32mm**  
Series OSP-P STL and KF

Installation: Side carrier  
Piston below

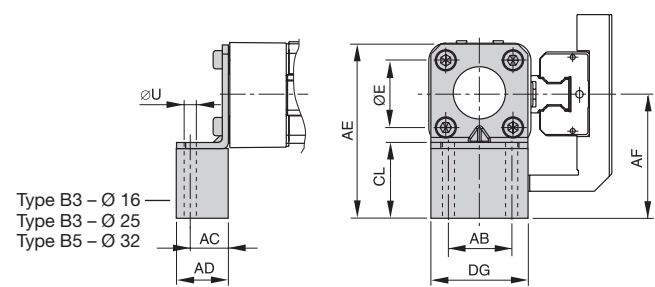

**Type B2: 16, 25, 32mm**  
Series OSP-P STL and KF

Installation: Side carrier  
Top piston

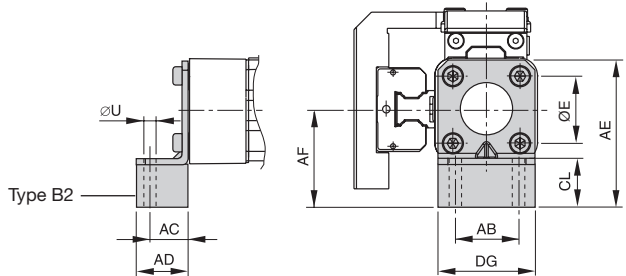

**Dimension (mm), Type B**

Series Type	Mounting	E	ØU	AB	AC	AD	AE	AF	CL	DG	Part Number (pair)
OSP-P STL16	B1	18	3.6	18	10	14	28	15	2	26	21135FIL
OSP-P KF16	B2	18	3.6	18	10	14	43	30	17	26	21136FIL
	B3	18	3.6	18	10	14	55	42	29	26	21137FIL
OSP-P STL25	B1	27	5.8	27	16	22	42	22	2.5	39	20311FIL
OSP-P KF25	B2	27	5.8	27	16	22	57	37	17.5	39	21138FIL
	B3	27	5.8	27	16	22	69	49	29.5	39	21139FIL
OSP-P STL32	B1	36	6.6	36	18	26	55	30	3	50	20313FIL
OSP-P KF32	B2	36	6.6	36	18	26	69	44	17	50	21140FIL
	B5	36	6.6	36	18	26	90	65	9	50	21141FIL

**G**  
 Rodless Pneumatic  
 Cylinders  
 OSP-P  
 Series  
 P1X  
 Series  
 GDL  
 Series



For inventory, lead times, and kit lookup, visit [www.pdnplu.com](http://www.pdnplu.com)



**Mid-Section Support – Type D1ST Ø 16 to 50mm**

For Linear-drive with Recirculating Ball Bearing Guide

- Series OSP-P STL
- Series OSP-P KF

**Note:** on Types D1ST

The mid-section support can also be mounted on the underside of the actuator, in which case its distance from the center of the actuator is different.

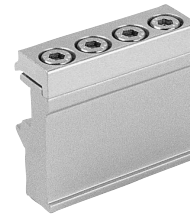

Drawing shows: Mounting with Guide Type STL  
Mountings from below with 2 screws

**Type D1ST: 16 to 50mm  
Series OSP-P STL and KF**

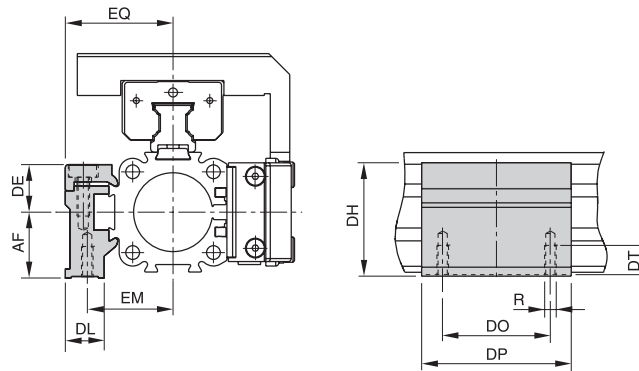

**Dimension (mm), Type D1ST**

Series OSP-P ...	Mounting	R	AF	DE	DH	DL	DO	DP	DT	EM	EQ	Part Number
STL/KF16	D1ST	M3	15	14.2	29.2	14.6	18	30	6.5	20	27	<b>21125FIL</b>
STL/KF25	D1ST	M5	22	16	38	13	36	50	10	28.5	36	<b>21126FIL</b>
STL/KF32	D1ST	M5	30	16	46	13	36	60	10	35.5	43	<b>21127FIL</b>
STL/KF40	D1ST	M6	38	23	61	19	45	60	11	38	48	<b>21128FIL</b>
STL/KF50	D1ST	M6	48	23	71	19	45	60	11	45	57	<b>21129FIL</b>

Order example: Type D1ST16 **Part number: 21125FIL**

**Technical Data, Mid-Section Support**

**Mid-Section Support**

**Information regarding type E1 and D1:**

Mounting of the Mid-Section supports is also possible on the lower side of the drive. In this case, please note the new center line dimensions.

Stainless steel version on request.



**Series OSP-P16 to 80: Type E**  
(Mounting from above / below using a cap screw)

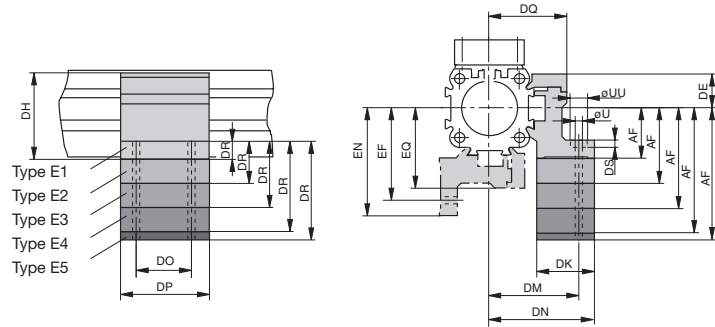

**Series OSP-P16 to 80: Type D1**  
(Mounting from below with thread screw)

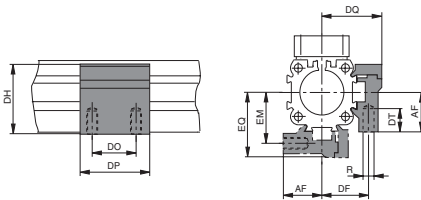

**Dimension (mm) - AF and DR (Dependent on the mounting type)**

Mount. type	DR for size								AF for size							
	16	25	32	40	50	63	80	16	25	32	40	50	63	80		
<b>D1</b>	-	-	-	-	-	-	-	15	22	30	38	48	57	72		
<b>E1</b>	6	8	10	10	10	12	15	15	22	30	38	48	57	72		
<b>E2</b>	21	23	24	23	19	-	-	30	37	44	51	57	-	-		
<b>E3</b>	33	35	32	32	34	48	53	42	49	52	60	72	93	110		
<b>E4</b>	-	46	40	42	57	-	-	-	60	60	70	95	-	-		
<b>E5</b>	-	-	45	-	-	-	-	-	-	65	-	-	-	-		

**Dimension Table (mm)**

Series	R	U	UU	DE	DF	DH	DK	DM	DN	DO	DP	DQ	DS	DT	EF	EM	EN	EQ
OSP-P16	M3	3.4	6	14.2	20	29.2	24	32	36.4	18	30	27	3.4	6.5	32	20	36.4	27
OSP-P25	M5	5.5	10	16	27	38	26	40	47.5	36	50	34.5	5.7	10	41.5	28.5	49	36
OSP-P32	M5	5.5	10	16	33	46	27	46	54.5	36	50	40.5	5.7	10	48.5	35.5	57	43
OSP-P40	M6	7	-	23	35	61	34	53	60	45	60	45	-	11	56	38	63	48
OSP-P50	M6	7	-	23	40	71	34	59	67	45	60	52	-	11	64	45	72	57
OSP-P63	M8	9	-	34	47.5	91	44	73	83	45	65	63	-	16	79	53.5	89	69
OSP-P80	M10	11	-	39.5	60	111.5	63	97	112	55	80	81	-	25	103	66	118	87

**Ordering information for mountings – Type A, Type B, Type C, Type D, Type E**

Mounting Type (versions)	Part number							
	16	25	32	40	50	63	80	
A1 †	20408FIL	2010	3010	-	-	-	-	
A2 †	20464FIL	-	3040FIL	-	-	-	-	
A3 †	-	2060FIL	3060FIL	-	-	-	-	
B1 †	-	20311FIL	20313FIL	-	-	-	-	
B3 †	20465FIL	-	-	-	-	-	-	
B4 †	-	20312FIL	20314FIL	-	-	-	-	
B5 †	-	-	20976FIL	-	-	-	-	
C1 †	-	-	21141FIL	4010FIL	5010FIL	6010FIL	8010FIL	
C2 †	-	-	-	20338FIL	20349FIL	-	-	
C3 †	-	-	-	20339FIL	20350FIL	20821FIL	20822FIL	
C4 †	-	-	-	20340FIL	20351FIL	-	-	
D1	20434FIL	20008FIL	20157FIL	20027FIL	20162FIL	20451FIL	20480FIL	
E1	20435FIL	20009FIL	20158FIL	20028FIL	20163FIL	20452FIL	20482FIL	
E2	20436FIL	20352FIL	20355FIL	20358FIL	20361FIL	-	-	
E3	20437FIL	20353FIL	20356FIL	20359FIL	20362FIL	20453FIL	20819FIL	
E4	-	20354FIL	20357FIL	20360FIL	20363FIL	-	-	
E5	-	-	20977FIL	-	-	-	-	

† Pair



For inventory, lead times, and kit lookup, visit [www.pdnplu.com](http://www.pdnplu.com)

**Mid-Section Support – Type E1ST to E5ST Ø 16 to 50mm**

For Linear-drive with Recirculating Ball Bearing Guide

- Series OSP-P STL
- Series OSP-P KF

Drawing shows: Mounting with Guide Type STL Mountings from below with 2 screws



**Type E1ST: 16 to 50mm**  
Series OSP-P STL and KF

Installation: **Top carrier**  
**Side position**

**Type E2ST: 16 to 50mm**  
Series OSP-P STL and KF

Installation: **Side carrier**  
**Top piston**

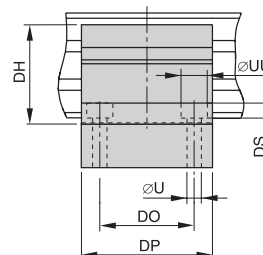
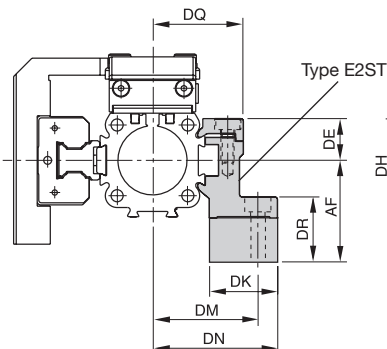
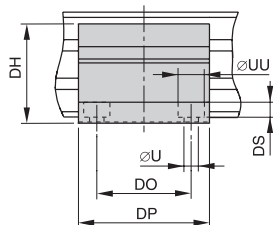
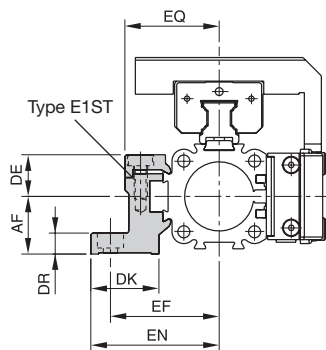

**Type E3ST, E4ST, E5ST: 25 to 50mm**  
Series OSP-P STL and KF

Installation: **Side carrier**  
**Piston below**

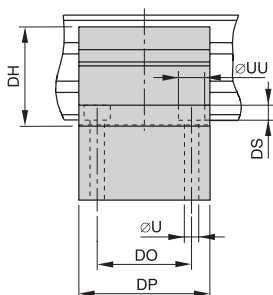
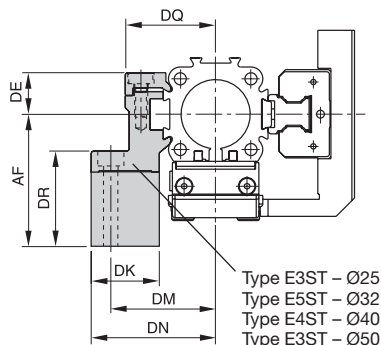

**Dimension (mm), Type E1ST to E5ST**

Series	Mounting	ØU	ØUU	AF	DE	DH	DK	DM	DN	DO	DP	DR	DQ	DS	EF	EN	EQ	Part Number
OSP-P ...	E1ST	3.4	6	15	14.2	29.2	24	32	36.4	18	30	6	27	3.4	32	36.4	27	21130FIL
	E2ST	3.4	6	30	14.2	29.2	24	32	36.4	18	30	21	27	3.4	32	36.4	27	21142FIL
	E1ST	5.5	10	22	16	38	26	40	47.5	36	50	8	34.5	5.7	41.5	49	36	21131FIL
	E2ST	5.5	10	37	16	38	26	40	47.5	36	50	23	34.5	5.7	41.5	49	36	21143FIL
	E3ST	5.5	10	49	16	38	26	40	47.5	36	50	35	34.5	5.7	41.5	49	36	21148FIL
	E1ST	5.5	10	30	16	46	27	46	54.5	36	60	10	40.5	5.7	48.5	57	43	21132FIL
	E2ST	5.5	10	44	16	46	27	46	54.5	36	60	24	40.5	5.7	48.5	57	43	21144FIL
	E5ST	5.5	10	65	16	46	27	46	54.5	36	60	45	40.5	5.7	48.5	57	43	21151FIL
	E1ST	7	-	38	23	61	34	53	60	45	60	10	45	-	56	63	48	21133FIL
	E2ST	7	-	51	23	61	34	53	60	45	60	23	45	-	56	63	48	21145FIL
	E4ST	7	-	70	23	61	34	53	60	45	60	42	45	-	56	63	48	21150FIL
	E1ST	7	-	48	23	71	34	59	67	45	60	10	52	-	64	72	57	21134FIL
	E2ST	7	-	57	23	71	34	59	67	45	60	19	52	-	64	72	57	21146FIL
	E3ST	7	-	72	23	71	34	59	67	45	60	34	52	-	64	72	57	21149FIL

Order example: Type E1ST16 Part number: 21130FIL



For inventory, lead times, and kit lookup, visit [www.pdnplu.com](http://www.pdnplu.com)

**G**

Rodless Pneumatic Cylinders

OSP-P Series

P1X Series

GDL Series

**Mid-Section Support – Type MUP Ø 25 to 50mm (correspond to FESTO dimensions)**

For Linear-drive with Recirculating Ball Bearing Guide

- Series OSP-P KF

**Note:** Correspond to FESTO DGPL-KF, when the Mid-Section Support MUP are mounted on the 90° side to the carriage (see drawings).

**Series OSP-P KF25: Type MUP**  
(Mounting over through holes)

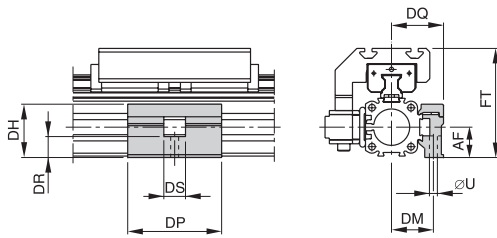

**Series OSP-P KF32 to KF40: Type MUP**  
(Mounting over through holes)

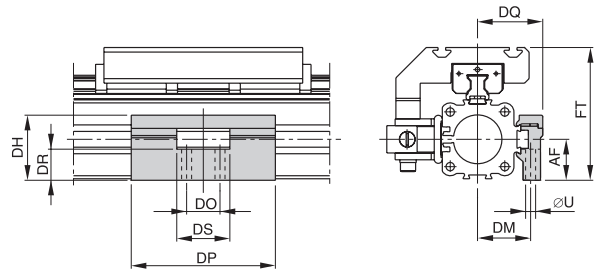

**Series OSP-P KF50: Type MUP**  
(Mounting over through holes)

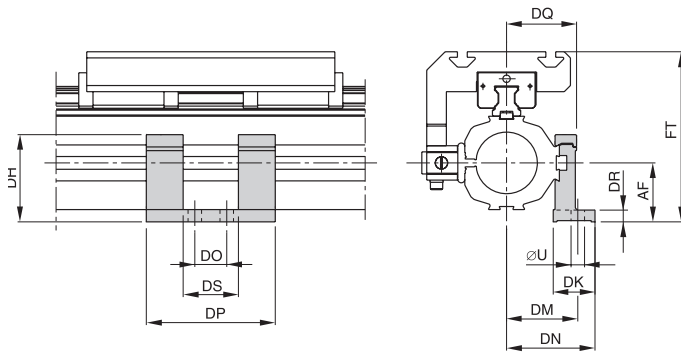

**Dimension (mm)**

Series	ØU	AF	DH	DK	DM	DN	DO	DP	DQ	DR	DS	FT	Part Number
MUP25	5.5	21	36.9	-	29	-	-	65	36	14.5	15	75.5	21119FIL
MUP32	6.6	27	42.9	-	35	-	22	95	43	20.5	35	87.5	21120FIL
MUP40	6.6	35	58	-	40	-	22	95	48	28.5	35	104.5	21121FIL
MUP50	11	48	71	34	58	72	26	105	57	10	45	138.5	21122FIL

  
 Rodless Pneumatic Cylinders  
 OSP-P Series  
 P1X Series  
 GDL Series

**End Cap Mountings – Type C Ø 40 to 50mm**

For Linear-drive with Recirculating Ball Bearing Guide

- Series OSP-P STL
- Series OSP-P KF

**Material:**

- Anodized aluminum

The mountings are supplied in pairs.  
Drawing shows: Mounting with Guide Type STL

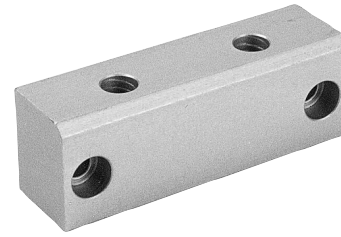

**Type C1: 40, 50mm**  
Series OSP-P STL and KF

Installation Top carrier  
Side piston

**Type C4: 40mm**  
**Type C3: 50mm**  
Series OSP-P STL and KF

Installation: Side carrier  
Piston below

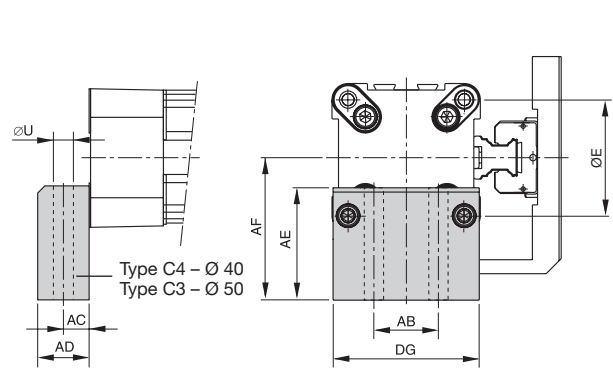
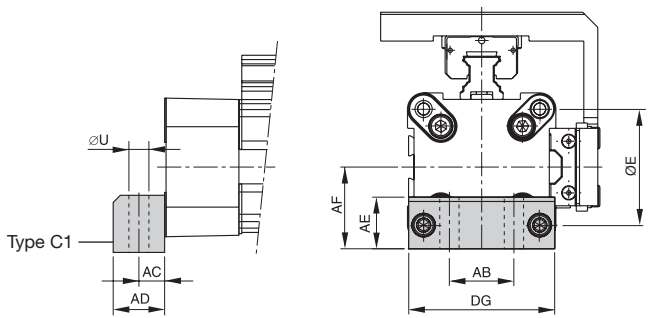

**Type C2: 40, 50mm**  
Series OSP-P STL and KF

Installation: Side carrier  
Top piston

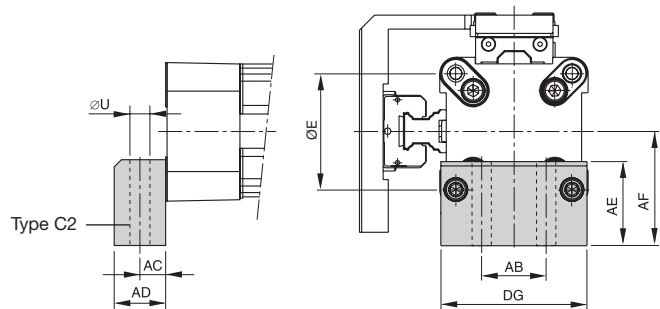

**Dimension (mm), Type C**

Series Type	Mounting	E	ØU	AB	AC	AD	AE	AF	DG	Part Number (pair)
OSP-P STL40	C1	54	9	30	12.5	24	24	38	68	4010FIL
OSP-P KF40	C2	54	9	30	12.5	24	37	51	68	20338FIL
	C4	54	9	30	12.5	24	56	70	68	20340FIL
OSP-P STL50	C1	70	9	40	12.5	24	30	48	86	5010FIL
OSP-P KF50	C2	70	9	40	12.5	24	39	57	86	20349FIL
	C3	70	9	40	12.5	24	54	72	86	20350FIL



Rodless Pneumatic  
Cylinders

OSP-P  
Series

P1X  
Series

GDL  
Series



For inventory, lead times, and kit lookup, visit [www.pdnplu.com](http://www.pdnplu.com)

G83

Parker Hannifin Corporation  
Pneumatic Division  
Wadsworth, Ohio  
[www.parker.com/pneumatics](http://www.parker.com/pneumatics)

**Dovetail Cover, Ø16 to 80mm**

- For clean guidance of magnetic switch cables along the cylinder body.
- Contains a maximum of 3 cables with diameter 3 mm.
- Material: Plastic
- Color: Red
- Temperature Range: -10 to 80°C

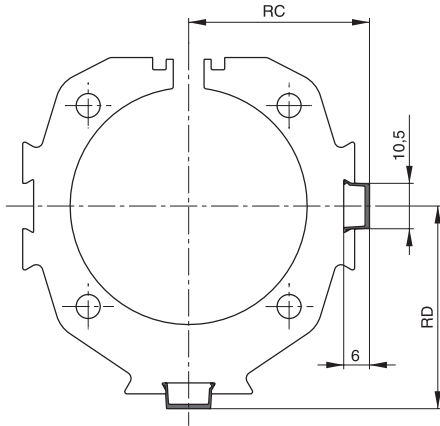
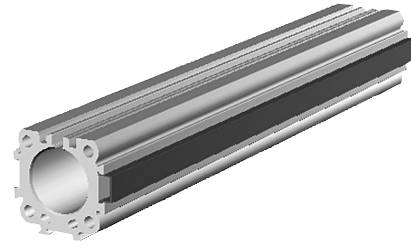

**Dimension (mm) and Order Instructions**

Series	Dimensions (mm)		Part Number
	RC	RD	
OSP-P16	18.5	19	<b>13039FIL</b>  Minimal length: 1m Max. profile length: 2m  Multiple profiles can be used.
OSP-P25	23.5	25.5	
OSP-P32	29.5	32	
OSP-P40	34.5	37.5	
OSP-P50	41.5	46.5	
OSP-P63	51.5	57.5	
OSP-P80	64.5	70.5	



**Metric Conversion Fittings**



Bore Size	Port Size	Part Number
P25	G1/8 to 1/8" NPT	<b>2521-1/8-02</b>
P32, P40, P50	G1/4 to 1/4" NPT	<b>2521-1/4-04</b>
P63	G3/8 to 3/8" NPT	<b>2521-3/8-06</b>
P80	G1/2 to 1/2" NPT	<b>2521-1/2-08</b>

Rodless Pneumatic  
 Cylinders

OSP-P  
 Series

P1X  
 Series

GDL  
 Series



**Service Packs**

	Bore Sizes							
	10mm	16mm	25mm	32mm	40mm	50mm	63mm	80mm
BUNA service pack single piston	3085x(stroke)	11111x(stroke)	11112x(stroke)	11113x(stroke)	11114x(stroke)	11115x(stroke)	11116x(stroke)	11118x(stroke)
Fluorocarbon service pack, single piston	3086x(stroke)	11121x(stroke)	11122x(stroke)	11123x(stroke)	11124x(stroke)	11125x(stroke)	11126x(stroke)	11128x(stroke)
BUNA service pack single piston - slow speed grease	—	11131x(stroke)	11132x(stroke)	11133x(stroke)	11134x(stroke)	11135x(stroke)	11136x(stroke)	11138x(stroke)
Fluorocarbon service pack, single piston - slow speed grease	—	11141x(stroke)	11142x(stroke)	11143x(stroke)	11144x(stroke)	11145x(stroke)	11146x(stroke)	11148x(stroke)

**Note:** (stroke) = stroke of cylinder in mm

**Service Pack Information**

Service Packs contain all the components necessary to completely rebuild a Parker rodless cylinder, are available. Each pack contains a complete seal kit, inner and outer bands, Parker grease tube, cleaning tool and repair instructions. It's all packaged in an easy-to-ship, easy-to-store box clearly labeled to indicate the cylinder type, bore and stroke for which it is intended. Contact your local Parker distributor for more information.

**Seal & Service Kits**

	Bore Sizes						
	16mm	25mm	32mm	40mm	50mm	63mm	80mm
BUNA seal kit - standard cylinder	11052	11053	11054	11055	11056	11057	11058
Fluorocarbon seal kit - standard cylinder	11059	11060	11061	11062	11063	11064	11065
Service kit active brake - sideline carriage	—	11095	11096	11097FIL	11098FIL	—	—
Service kit active brake - standard cylinder	—	11822FIL	11823FIL	11824FIL	11825FIL	11826FIL	11827FIL
Service kit - multibrake	—	11089FIL	11090FIL	11091FIL	11092FIL	11093FIL	—

**Seal Kit Information**

Seal Kits include all seals, a tube of grease, bearing shoe, scraper and cleaning tool.



Rodless Pneumatic Cylinders

OSP-P Series

P1X Series

GDL Series



For inventory, lead times, and kit lookup, visit [www.pdnplu.com](http://www.pdnplu.com)

**Displacement Measuring System for Automated Movement**

**Series SFI-plus (incremental measuring system)  
for cylinder series**

- OSP-P...

**Characteristics**

- Contactless magnetic displacement measurement system
- Displacement length up to 5.5 m
- Resolution 0.1 mm (option: 1 mm)
- Displacement speed up to 10 m/s
- For linear and non-linear rotary motion
- Suitable for almost any control or display unit with a counter input

The SFI-plus magnetic displacement measuring system consists of 2 main components.

- **Measuring Scale**, self-adhesive magnetic measuring scale

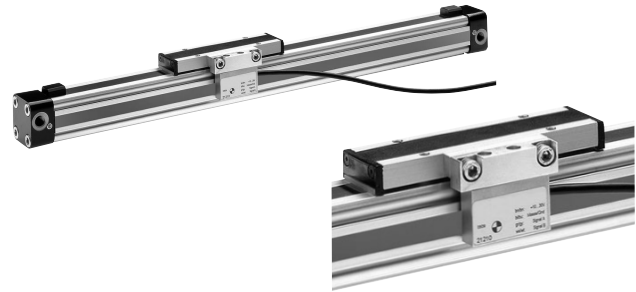

- **Sensing Head**, converts the magnetic poles into electrical signals which are then processed by counter inputs downstream (e.g. PLC, PC, digital counter)

**Note:** For combinations Active Brake AB + SFI-plus + Magnetic Switch contact our technical department please.

**Characteristics**

	Type 21210FIL	Type 21211FIL
<b>Output Function</b>		
Resolution	0.1mm	1mm
Pole lengths magnetic scale	5mm	5mm
Maximum speed	10 m/s	10 m/s
Repeat accuracy	± 1 Increment	± 1 Increment
Distance between sensor and scale	≤ 4mm	≤ 4mm
Tangential deviation	≤ 5°	≤ 5°
Lateral deviation	≤ ± 1.5 mm	≤ ± 1.5 mm
Switching output	PNP	PNP
<b>Electrical Characteristics</b>		
Operating voltage $U_b$	18 – 30 V DC	18 – 30 V DC
Voltage drop	≤ 2 V	≤ 2 V
Continuous current for each output	≤ 20 mA	≤ 20 mA
Power consumption at $U_b = 24V$ , switched on, without load	≤ 50 mA	≤ 50 mA
Short-circuit protection	yes	yes
Reverse polarity protection	–	yes
Protection from inductive load	yes	yes
Power-up pulse suppression	yes	yes

	Type 21210FIL / 21211FIL
<b>EMC</b>	
Electrostatic discharge immunity	6, B, to EN 61000-4-2 kV
Electromagnetic field immunity	10, A, to EN61000-4-3 V/m
Electrical fast transient/burst immunity (for signal connections)	1, B, to EN 61000-4-4 kV
Electrical fast transient/burst immunity (for DC connections)	2, B, to EN 61000-4-4 kV
Surge immunity (for signal connections)	1, B, to EN 61000-4-5 kV
Surge immunity (for DC connections)	0,5, B, to EN 61000-4-5 kV
Immunity to conducted disturbances	10, A, to EN 61000-4-6 V
Power frequency magnetic field immunity at 50 Hz	30, A, to EN 61000-4-8 A/m
Emission standard for residential	to EN 61000-6-4
Radio disturbance characteristics	to EN 55011, Group 1, A
<b>Mechanical Characteristics</b>	
Housing	Aluminum
Cable length	5.0 m – fixed, open end
Cable cross section	4 x 0.14 mm <sup>2</sup>
Cable type	PUR, black
Bending radius	≥ 36 mm
Weigh (mass)	ca. 0.165 kg
<b>Environmental Conditions / Shock Resistance</b>	
Degree of protection	IP67 to EN60529
Ambient temperature range	-25°C to 80°C
Broad-band random vibration to EN 60068-2-64	5 g, 5 Hz to 2 kHz, 0.5 h each axis
Vibration stress to EN 60068-2-6	12 g, 10 Hz to 2 kHz, 2 mm, 5 h each axis
Shock to EN 60068-2-27	100 g, 6 ms, 50 bumps each axis
Bump to EN 60068-2-29	5 g, 2 ms, 8000 bumps each axis

**G**  
 Rodless Pneumatic Cylinders  
 OSP-P Series  
 P1X Series  
 GDL Series



For inventory, lead times, and kit lookup, visit [www.pdnplu.com](http://www.pdnplu.com)



**Sensing Head**

The sensing head provides two pulsating, 90° out of phase counter signals (phase A/B) with a 0.4 mm resolution (option 4 mm).

External processing can improve the resolution to 0.1 mm (option 1 mm).

The counting direction can be determined automatically from the phase variance of the counter signals.

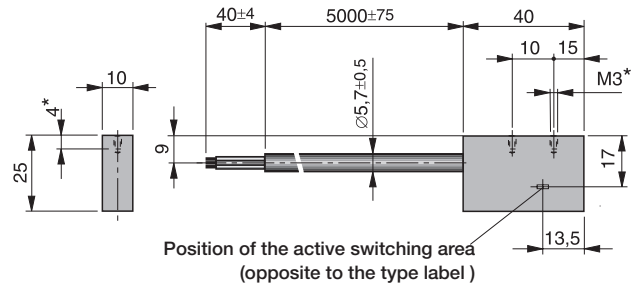

\* Maximum thread depth 4mm

**Electrical Connection**

Color7	Description
RD = Red	10-30 VDC
BL = Black	Ground
YE = Yellow	Phase A
GN = Green	Phase B

**Output signal – Sensing Head**

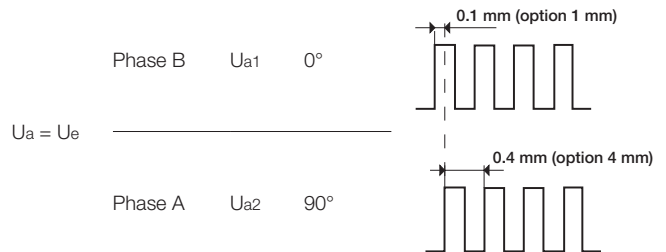

**SFI-plus mounted on a rodless cylinder series OSP-P**

The SFI-plus system can be mounted directly on a rodless OSP-P cylinder with the special mounting kit.

The position of the sensing head is generally 90° to the carrier.

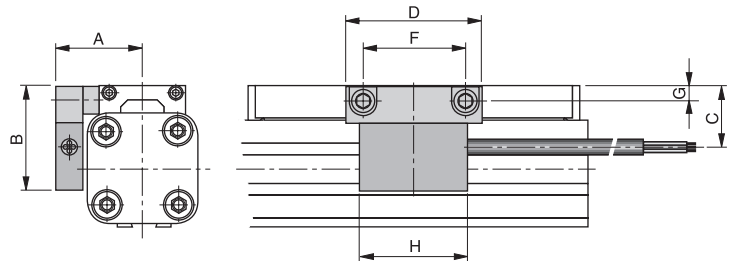

**Combinations consisting of SFI-plus and OSP-P Cylinders with guides are available on request.**

**Dimension (mm)**

Series	A	B	C	D	F	G	H
OSP-P25	32	39	23	50	38	5.5	40
OSP-P32	37.5	46	30	50	38	6.5	40
OSP-P40	42.5	50	34	50	38	6.5	40
OSP-P50	49.5	55	39	50	38	6.5	40
OSP-P63	59.5	65	49	50	38	10	40
OSP-P80	72.5	80	64	50	38	12	40



**Rodless Pneumatic Cylinders**

**OSP-P Series**

**P1X Series**

**GDL Series**



For inventory, lead times, and kit lookup, visit [www.pdnplu.com](http://www.pdnplu.com)

**Order instructions**

Description	Part Number
Sensing head with measuring scale – Resolution 0.1 mm (scale length = required measuring distance + a minimum of – see table below)	<b>21240x(stroke)</b>
Option: Sensing head with measuring scale – Resolution 1 mm (scale length = required measuring distance + a minimum of – see table below)	<b>21241x(stroke)</b>
Sensing head – Resolution 0.1 mm (spare part)	<b>21210FIL</b>
Option: Sensing head – Resolution 1 mm (spare part)	<b>21211FIL</b>
Measuring scale per meter (spare part)	<b>21235FIL</b>
Mounting kit for OSP-P25	<b>21213FIL</b>
Mounting kit for OSP-P32	<b>21214FIL</b>
Mounting kit for OSP-P40	<b>21215FIL</b>
Mounting kit for OSP-P50	<b>21216FIL</b>
Mounting kit for OSP-P63	<b>21217FIL</b>
Mounting kit for OSP-P80	<b>21218FIL</b>

\* Overall length of the measuring scale results from stroke length of the cylinder + dead length  
Dead length for linear drives series OSP-P see table.

Series	Dead length (mm)
OSP-P 25	154
OSP-P 32	196
OSP-P 40	240
OSP-P 50	280
OSP-P 63	350
OSP-P 80	422

**Example:**

Cylinder OSP-P, Ø25 mm, stroke length 1000 mm

$$\begin{array}{rcl}
 \text{dead length} & + & \text{stroke length} & = & \text{overall length of the measuring scale} \\
 154 \text{ mm} & + & 1000 \text{ mm} & = & 1154 \text{ mm}
 \end{array}$$

**Rodless Pneumatic Cylinders**  
 OSP-P Series  
 P1X Series  
 GDL Series



For inventory, lead times, and kit lookup, visit [www.pdnplu.com](http://www.pdnplu.com)

**P1X Series**

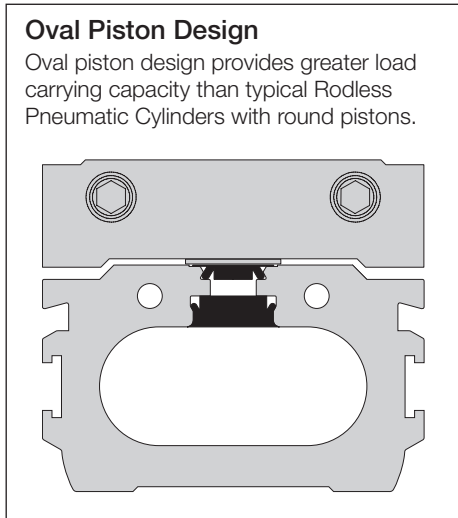
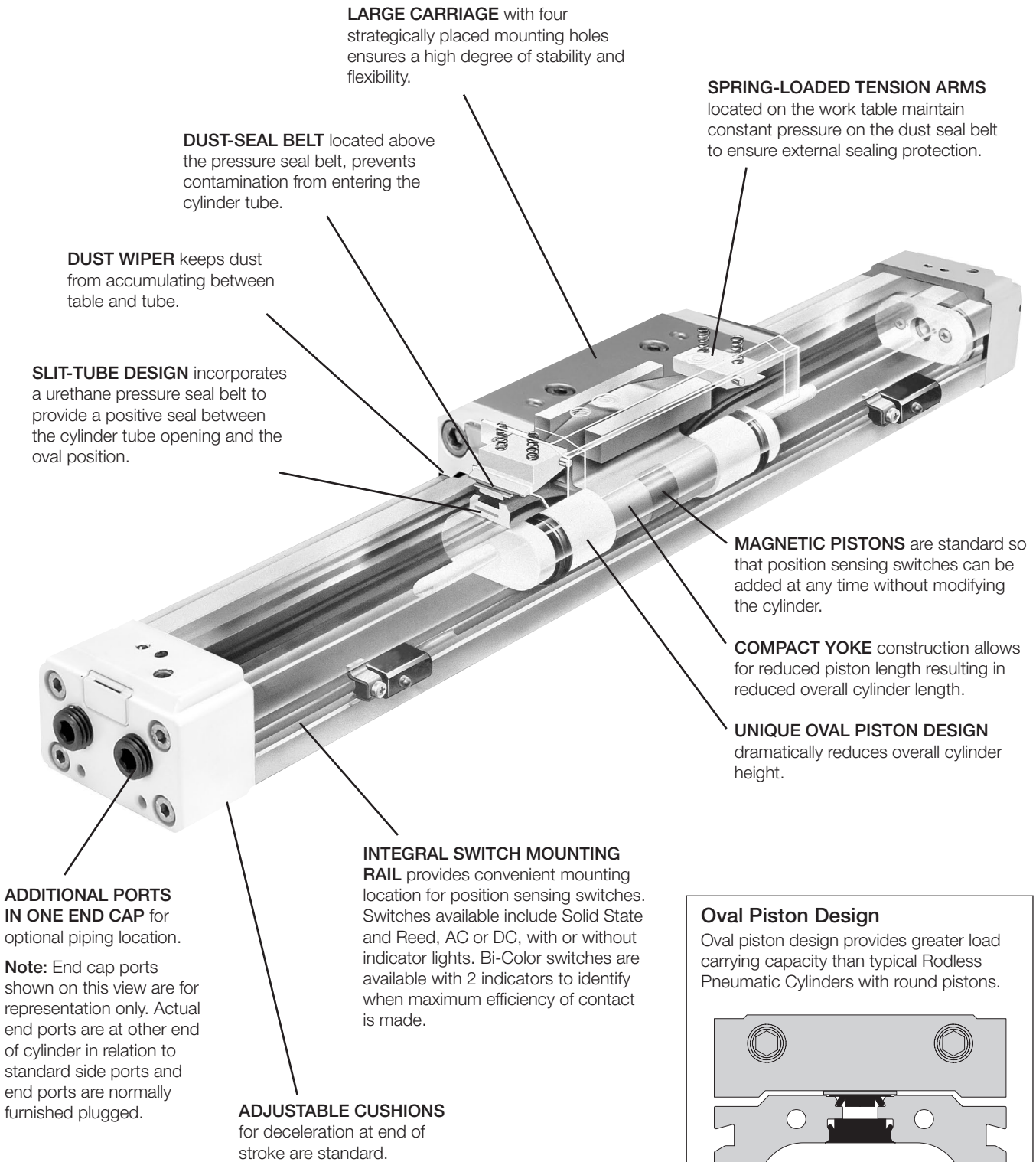

<b>G</b>	Rodless Pneumatic Cylinders
	OSP-P Series
P1X Series	GDL Series



For inventory, lead times, and kit lookup, visit [www.pdnplu.com](http://www.pdnplu.com)

## Features

- 7 bore sizes – 16mm through 63mm
- Two port locations standard
- Large carriage for stability
- Integral sensor mounting rail
- Optional adjustable stroke and shock absorbers
- Stroke: maximum 5000mm, minimum 25mm



## Operating information

Maximum pressure:	100 PSIG (7 bar)	
Minimum pressure:	Ø16, Ø20 bores	29 PSI (2 bar)
	Ø25, Ø32, Ø40 bores	14.5 PSI (1 bar)
	Ø50, Ø63 bores	7 PSI (0.5 bar)
Proof pressure:	152 PSI (10.5 bar)	
Temperature range:	40°F to 140°F (5°C to 60°C)	
Filtration requirements:	Filtered, nonlubricated compressed air	

## Ordering Information

<b>P1X</b>	<b>N</b>	<b>032</b>	<b>D</b>	<b>A</b>	<b>N</b>	<b>0500</b>	<b>W</b>	<b>D</b>	<b>N</b>	<b>N</b>	<b>N</b>	<b>-B</b>																																																																																																													
<table border="1" style="width:100%; border-collapse: collapse;"> <tr><th colspan="2">Series</th></tr> <tr><td>P1X</td><td>Global Rodless</td></tr> </table>	Series		P1X	Global Rodless	<table border="1" style="width:100%; border-collapse: collapse;"> <tr><th colspan="2">Construction</th></tr> <tr><td>N</td><td>Inch</td></tr> <tr><td>M</td><td>Metric</td></tr> </table>	Construction		N	Inch	M	Metric	<table border="1" style="width:100%; border-collapse: collapse;"> <tr><th colspan="2">Bore Size</th></tr> <tr><td>016</td><td>16mm</td></tr> <tr><td>020</td><td>20mm</td></tr> <tr><td>025</td><td>25mm</td></tr> <tr><td>032</td><td>32mm</td></tr> <tr><td>040</td><td>40mm</td></tr> <tr><td>050</td><td>50mm</td></tr> <tr><td>063</td><td>63mm</td></tr> </table>	Bore Size		016	16mm	020	20mm	025	25mm	032	32mm	040	40mm	050	50mm	063	63mm	<table border="1" style="width:100%; border-collapse: collapse;"> <tr><th colspan="2">Carriage</th></tr> <tr><td>D</td><td>Double Acting</td></tr> </table>	Carriage		D	Double Acting	<table border="1" style="width:100%; border-collapse: collapse;"> <tr><th colspan="2">Piston / Shock Style</th></tr> <tr><td>A</td><td>Cushions Both Ends (standard)</td></tr> <tr><td>R</td><td>Cushion Right End Only*</td></tr> <tr><td>L</td><td>Cushion Left End Only*</td></tr> <tr><td>N</td><td>No Cushions or Shock Absorbers</td></tr> <tr><td>H</td><td>Shock Absorber Both Ends</td></tr> <tr><td>B</td><td>Shock Absorber Right End Only</td></tr> <tr><td>C</td><td>Shock Absorber Left End Only</td></tr> </table>	Piston / Shock Style		A	Cushions Both Ends (standard)	R	Cushion Right End Only*	L	Cushion Left End Only*	N	No Cushions or Shock Absorbers	H	Shock Absorber Both Ends	B	Shock Absorber Right End Only	C	Shock Absorber Left End Only	<table border="1" style="width:100%; border-collapse: collapse;"> <tr><th colspan="2">Seal material</th></tr> <tr><td>N</td><td>Standard</td></tr> </table>	Seal material		N	Standard	<table border="1" style="width:100%; border-collapse: collapse;"> <tr><th colspan="2">Stroke Length*</th></tr> <tr><td>B†</td><td>Standard</td></tr> <tr><td>W†</td><td>With Options</td></tr> <tr><td>/</td><td>Special (for factory use only)</td></tr> </table>	Stroke Length*		B†	Standard	W†	With Options	/	Special (for factory use only)	<table border="1" style="width:100%; border-collapse: collapse;"> <tr><th colspan="2">Basic or Options</th></tr> <tr><td>B†</td><td>Standard</td></tr> <tr><td>W†</td><td>With Options</td></tr> <tr><td>/</td><td>Special (for factory use only)</td></tr> </table>	Basic or Options		B†	Standard	W†	With Options	/	Special (for factory use only)	<table border="1" style="width:100%; border-collapse: collapse;"> <tr><th colspan="2">Porting Options</th></tr> <tr><td>N</td><td>NPTF (Std)</td></tr> <tr><td>G</td><td>BSPP</td></tr> <tr><td>Q</td><td>BSPT*</td></tr> </table> <p style="font-size: small;">* Not available with N construction</p>	Porting Options		N	NPTF (Std)	G	BSPP	Q	BSPT*	<table border="1" style="width:100%; border-collapse: collapse;"> <tr><th colspan="2">Carriage Mounting Style</th></tr> <tr><td>D</td><td>Basic Mount</td></tr> <tr><td>A</td><td>Swivel Mount</td></tr> </table>	Carriage Mounting Style		D	Basic Mount	A	Swivel Mount	<table border="1" style="width:100%; border-collapse: collapse;"> <tr><th colspan="4">Mounting Options</th></tr> <tr> <th>No Foot Mount</th> <th>End Mount Foot Bracket</th> <th>Bottom Mount Foot Bracket</th> <th>Intermediate Supports</th> </tr> <tr> <td>N (std)</td> <td>F</td> <td>A††</td> <td>No Support</td> </tr> <tr> <td>H</td> <td>M</td> <td>B††</td> <td>One Support</td> </tr> <tr> <td>K</td> <td>P</td> <td>C††</td> <td>Two Supports</td> </tr> <tr> <td>T</td> <td>R</td> <td>D††</td> <td>Three Supports</td> </tr> </table>	Mounting Options				No Foot Mount	End Mount Foot Bracket	Bottom Mount Foot Bracket	Intermediate Supports	N (std)	F	A††	No Support	H	M	B††	One Support	K	P	C††	Two Supports	T	R	D††	Three Supports	<table border="1" style="width:100%; border-collapse: collapse;"> <tr><th colspan="2">Fastener Type</th></tr> <tr><td>N</td><td>Standard - Zinc-Plated</td></tr> <tr><td>S</td><td>Stainless Steel</td></tr> </table>	Fastener Type		N	Standard - Zinc-Plated	S	Stainless Steel
Series																																																																																																																									
P1X	Global Rodless																																																																																																																								
Construction																																																																																																																									
N	Inch																																																																																																																								
M	Metric																																																																																																																								
Bore Size																																																																																																																									
016	16mm																																																																																																																								
020	20mm																																																																																																																								
025	25mm																																																																																																																								
032	32mm																																																																																																																								
040	40mm																																																																																																																								
050	50mm																																																																																																																								
063	63mm																																																																																																																								
Carriage																																																																																																																									
D	Double Acting																																																																																																																								
Piston / Shock Style																																																																																																																									
A	Cushions Both Ends (standard)																																																																																																																								
R	Cushion Right End Only*																																																																																																																								
L	Cushion Left End Only*																																																																																																																								
N	No Cushions or Shock Absorbers																																																																																																																								
H	Shock Absorber Both Ends																																																																																																																								
B	Shock Absorber Right End Only																																																																																																																								
C	Shock Absorber Left End Only																																																																																																																								
Seal material																																																																																																																									
N	Standard																																																																																																																								
Stroke Length*																																																																																																																									
B†	Standard																																																																																																																								
W†	With Options																																																																																																																								
/	Special (for factory use only)																																																																																																																								
Basic or Options																																																																																																																									
B†	Standard																																																																																																																								
W†	With Options																																																																																																																								
/	Special (for factory use only)																																																																																																																								
Porting Options																																																																																																																									
N	NPTF (Std)																																																																																																																								
G	BSPP																																																																																																																								
Q	BSPT*																																																																																																																								
Carriage Mounting Style																																																																																																																									
D	Basic Mount																																																																																																																								
A	Swivel Mount																																																																																																																								
Mounting Options																																																																																																																									
No Foot Mount	End Mount Foot Bracket	Bottom Mount Foot Bracket	Intermediate Supports																																																																																																																						
N (std)	F	A††	No Support																																																																																																																						
H	M	B††	One Support																																																																																																																						
K	P	C††	Two Supports																																																																																																																						
T	R	D††	Three Supports																																																																																																																						
Fastener Type																																																																																																																									
N	Standard - Zinc-Plated																																																																																																																								
S	Stainless Steel																																																																																																																								
<p>* Stroke is ALWAYS in mm.</p> <p>† When "B" is specified, the remaining digits in the part number are not necessary. If "W" is used, the remaining digits in the part number must be filled out.</p> <p>†† Not available on 40, 50 and 63mm bore sizes.</p>																																																																																																																									
<p><input type="checkbox"/> Essential Information</p> <p><input checked="" type="checkbox"/> Optional Features</p>																																																																																																																									
<p><b>Sensors</b> See section L for sensors. </p>																																																																																																																									

G

Rodless Pneumatic Cylinders

OSP-P Series

P1X Series

GDL Series



For inventory, lead times, and kit lookup, visit [www.pdnplu.com](http://www.pdnplu.com)

G90

**Parker Hannifin Corporation**  
Pneumatic Division  
Wadsworth, Ohio  
[www.parker.com/pneumatics](http://www.parker.com/pneumatics)

**Specifications, Weights and Forces**

**Specifications - P1X (standard with switch)**

- Operating Medium: Compressed Air
- Bore Size mm (inch nominal): 16 (5/8) 20 (3/4), 25 (1) 32 (1-1/4), 40 (1-1/2) 50 (2), 63 (2-1/2)
- Port Size – N Series: M5 (10-32) 1/8 NPT 1/4 NPT 3/8 NPT
- Port Size – M Series: M5 (10-32) 1/8 Rc 1/4 Rc 3/8 Rc
- Stroke Tolerance in.: ±0.080 to 39" ±0.100 to 118" ±0.120 to 196"
- Piston Speed, \*in./sec.: 2-80 IPS with side ports on each end  
(Ø16 & Ø20 bores 2-40 IPS with single end porting with 39" stroke)  
(Ø25, Ø32, Ø40, Ø50 & Ø63 bores 2-40 IPS with single end porting with 78" stroke)
- Cushion: Air Cushion Standard
- Lubrication: Not Required (if you choose to lubricate your system, continuing lubrication will be required.)

\*Note: Actual piston speed with one end ports will vary depending on stroke length.

**Weight & Theoretical Force Characteristics**

		Weights								Theoretical Force (lbs)				
		Weight at Zero Stroke								at Pressure (PSI)				
Bore	Area In <sup>2</sup>	No Foot Mount		End Mount Foot Bracket		Bottom Mount Foot Bracket		Weight per 1" (25.4mm) Stroke						
		lbs	kg	lbs	kg	lbs	kg	lbs	kg	30	40	60	80	100
16	0.31	0.70	0.3	0.73	0.3	0.77	0.4	0.07	0.03	9	12	19	25	31
20	0.49	1.15	0.5	1.19	0.5	1.28	0.6	0.10	0.04	15	20	29	39	49
25	0.84	2.21	1.0	2.43	1.1	2.43	1.1	0.15	0.07	23	30	46	61	76
32	1.26	3.31	1.5	3.53	1.6	3.75	1.7	0.20	0.09	38	50	69	100	125
40	1.96	5.29	2.4	5.51	2.5	—	—	0.27	0.12	59	78	117	156	195
50	3.08	7.94	3.6	8.16	3.7	—	—	0.40	0.18	91	122	182	243	304
63	4.86	13.67	6.2	14.33	6.5	—	—	0.63	0.28	145	193	290	386	483

**Replacement Seal Kits**  
(includes inner & outer bands)

Bore (mm)	Part Number
16	L079020016-(stroke)
20	L079020020-(stroke)
25	L080100025-(stroke)
32	L080100032-(stroke)
40	L080100040-(stroke)
50	L080100050-(stroke)
63	L080100063-(stroke)

  
 Rodless Pneumatic Cylinders  
 OSP-P Series  
 P1X Series  
 GDL Series



For inventory, lead times, and kit lookup, visit [www.pdnplu.com](http://www.pdnplu.com)

**Moments**

Figure 1 shows the maximum allowable moments for each of the three types of loading: pitch, roll and yaw.

The sum total of each of these types of moments, divided by each of the maximum values, determines a Load-Moment Factor (LMF) should be equal to or less than 1.0. On horizontal mountings, the total load (L) should also be divided by the maximum load allowable (Figure 2) and factored into the equation.

Horizontal mountings:

$$\frac{L}{[L]} + \frac{M}{[M]} + \frac{Ms}{[Ms]} + \frac{Mv}{[Mv]} = LMF \leq 1.0$$

Vertical mountings:

$$\frac{M}{[M]} + \frac{Ms}{[Ms]} + \frac{Mv}{[Mv]} = LMF \leq 1.0$$

**Figure 1**

Maximum allowable moments n-m (lb-in)

Bore size	[M]		[Ms]		[Mv]	
	Pitch Moment		Roll Moment		Yaw Moment	
	Std.	Inverted	Std.	Inverted	Std.	Inverted
16	5 (44)	3.5 (31)	1 (9)	0.5 (4)	1 (9)	1 (9)
20	10 (89)	7 (62)	1.5 (13)	0.7 (6)	3 (27)	3 (27)
25	17 (150)	12 (106)	5 (44)	2.5 (22)	10 (89)	10 (89)
32	36 (319)	25 (221)	10 (89)	5 (44)	21 (186)	21 (186)
40	77 (682)	54 (478)	23 (204)	11.5 (102)	26 (230)	26 (230)
50	154 (1363)	108 (956)	32 (283)	16 (142)	42 (372)	42 (372)
63	275 (2434)	193 (1708)	52 (460)	26 (230)	76 (673)	76 (673)

**Load and Deflection**

Figure 2 shows the maximum load [L] that the cylinder can accept, as well as the maximum length [D] between supports at the maximum load.

Horizontal—Load Above

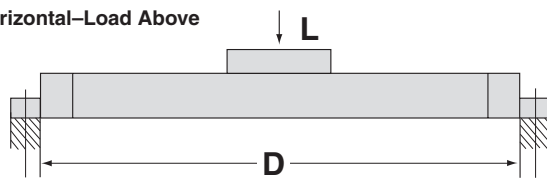

Horizontal—Load Below

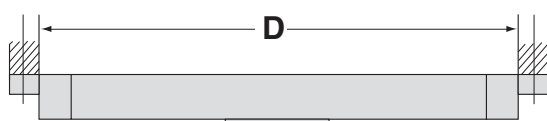

Horizontal—Tube Support

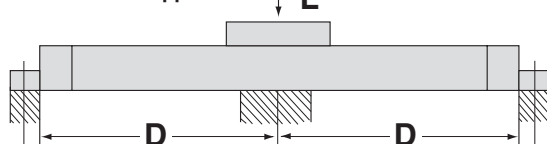
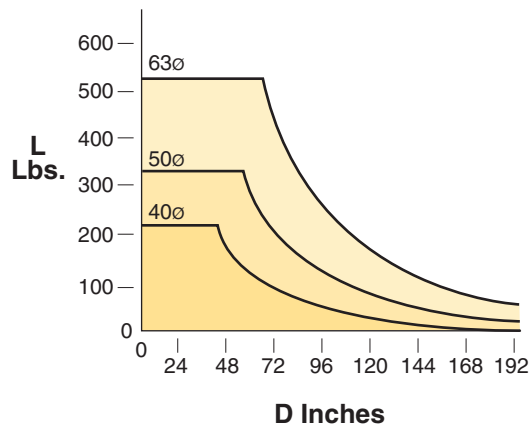
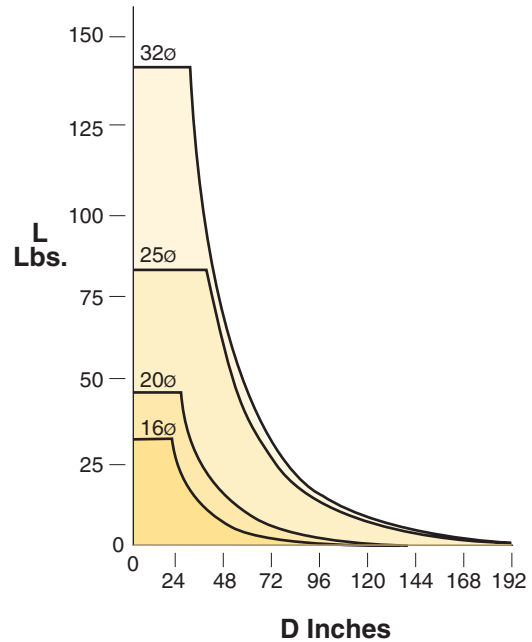

**Figure 2**

Bore Size	Max. Allowable Load [L] N (lbs)		Max. Unsupported Length mm (in) at Max. Load
	Std.	Inverted	
16	141 (32)	70 (16)	450 (17.7)
20	198 (45)	101 (23)	551 (21.7)
25	356 (81)	180 (41)	899 (35.4)
32	616 (140)	308 (70)	749 (29.5)
40	959 (218)	480 (109)	1000 (39.4)
50	1456 (331)	726 (165)	1300 (51.2)
63	2297 (522)	1148 (261)	1600 (63.0)

Acceptable length and load combinations for various bore sizes can be determined from the charts in Figure 3.

**Figure 3**



To determine cylinder deflections under the load (or resistive force perpendicular to the piston table) without mid-support, see the graphs on page G105.

**Inertia Moment Consideration**

When the weight is stopped at the end of the stroke by the cylinder cushion, inertial force is created. This inertial force (Fi) can be determined by using the formula:

- Fi = LG**
- L** = Load attached to the cylinder carriage (lbs.)
- G** = Inertia factor (Figure 1)

**Example:**

A speed of 40 in/sec corresponds to an inertia factor G of 13.

The inertial force calculated would then be multiplied by the distance from the center of gravity of the load to the centerline of the cylinder, and added to the previously calculated M and Mv moments. This will give an M Total and Mv Total. Ensure that the M Total and the Mv Total do not exceed the [M] and [Mv] values shown in Figure 5 (previous page). If they exceed these values, consult the factory.

See pages G105-G106 for additional information on shock absorbers.

**Figure 1**

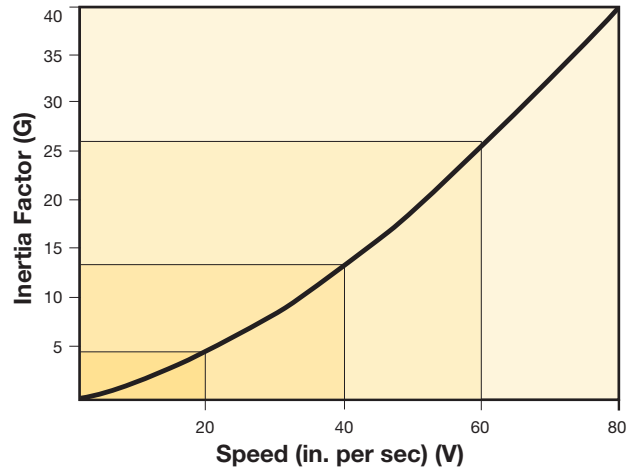

**External Stops**

When the load attached to the cylinder is stopped externally, it creates an additional moment equal to the cylinder force (Fa) times the distance (S). This additional moment, plus the previously calculated Load-Moment factor, should not exceed the allowable values. See previous page.

When reducing the stroke with external stops, remember that the cushion length and the energy absorption capacity are not directly proportional. Reducing the cushioning distance by 50% corresponds to a reduction of 60-70% in cushion effectiveness.

**Figure 9**

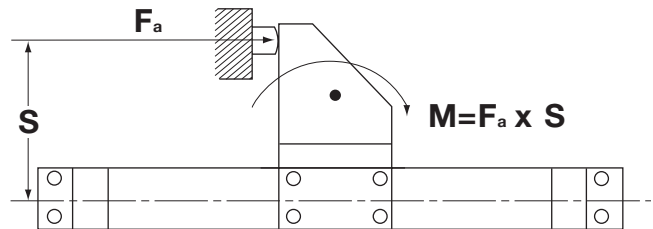

**G**

Rodless Pneumatic Cylinders

OSP-P Series

P1X Series

GDL Series



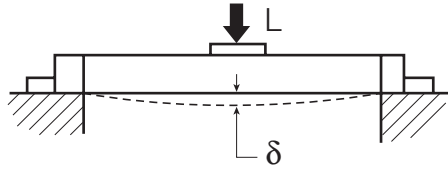

**32 mm Bore**

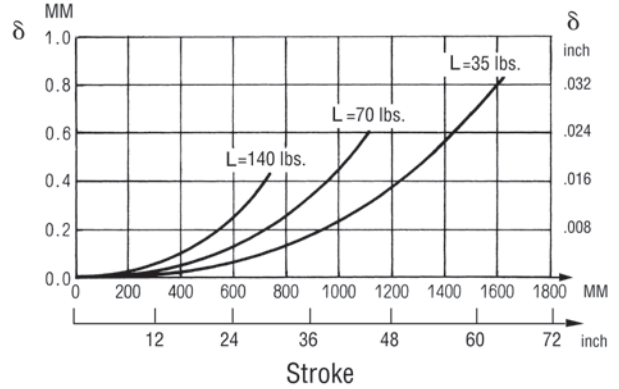

**16 mm Bore**

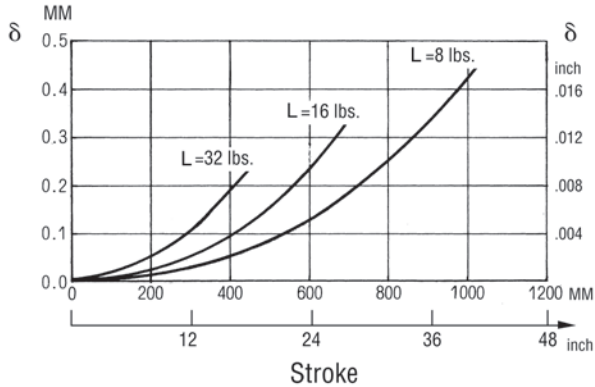

**40 mm Bore**

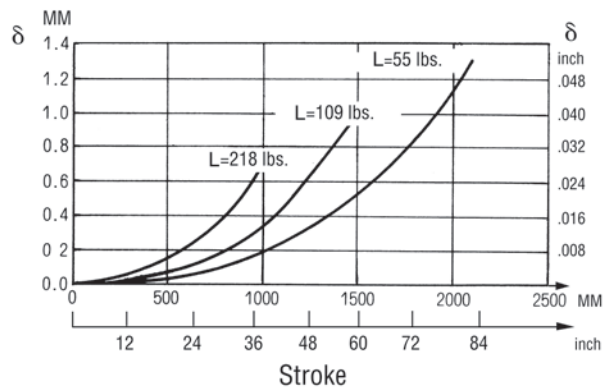

**20 mm Bore**

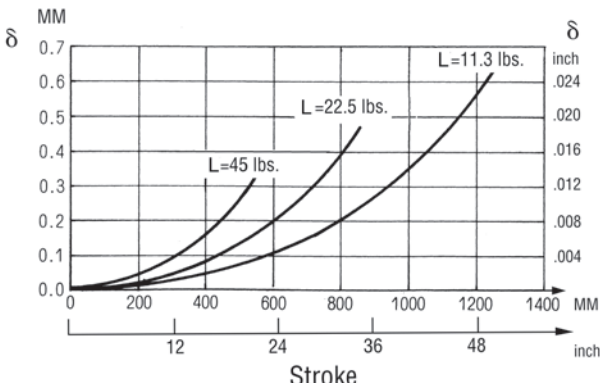

**50 mm Bore**

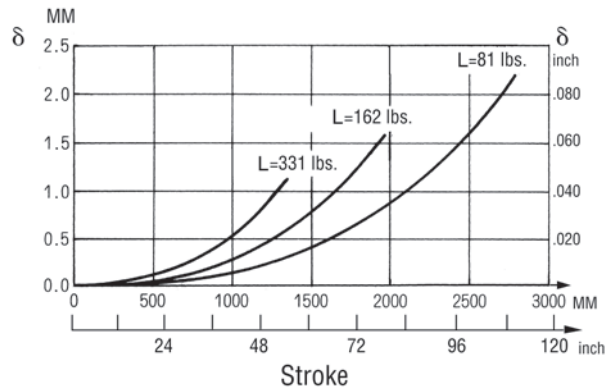

**25 mm Bore**

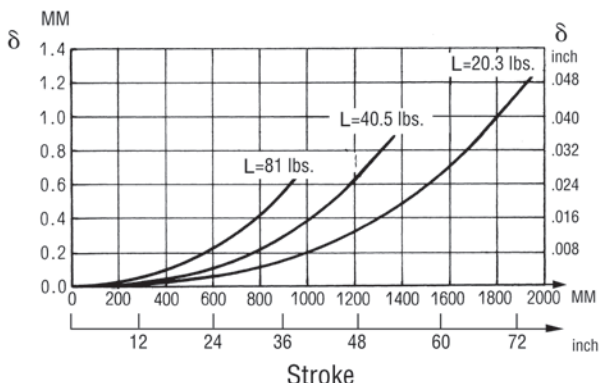

**63 mm Bore**

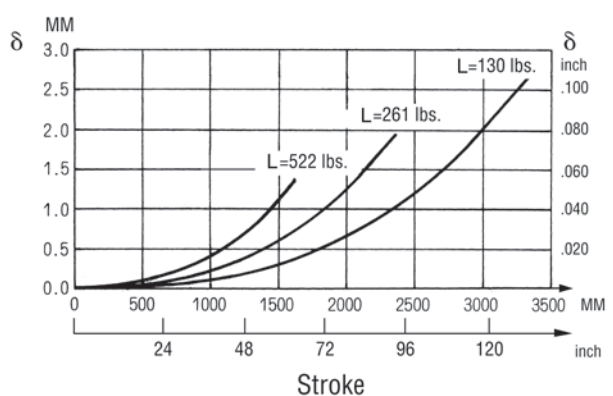

**G**  
 Rodless Pneumatic  
 Cylinders  
 OSP-P  
 Series  
 P1X  
 Series  
 GDL  
 Series



For inventory, lead times, and kit lookup, visit [www.pdnplu.com](http://www.pdnplu.com)



**Piston Table Angular Deflection Due To Load Moments Applied**

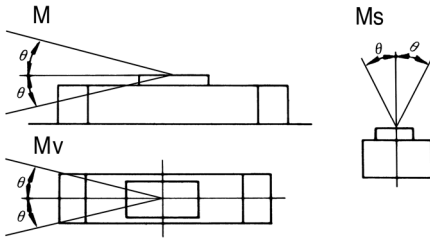

**32 mm Bore**

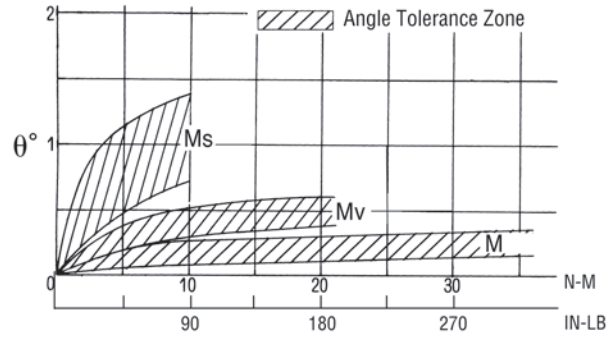

**16 mm Bore**

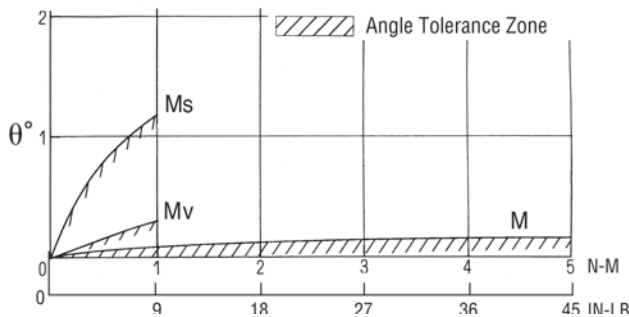

**40 mm Bore**

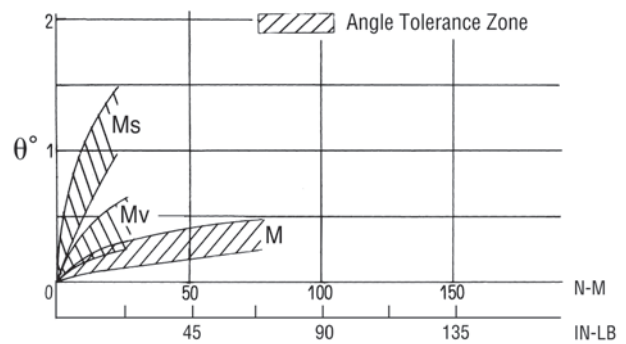

**20 mm Bore**

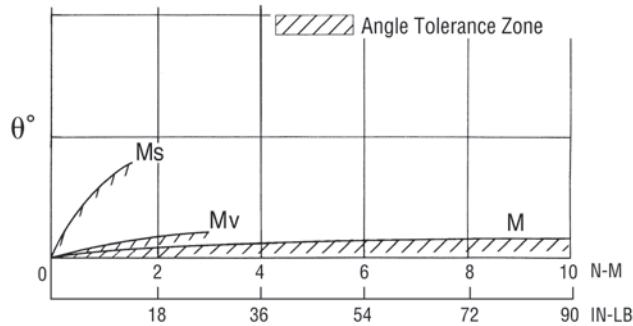

**50 mm Bore**

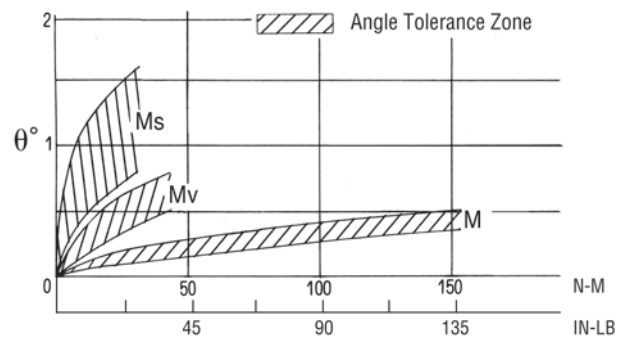

**25 mm Bore**

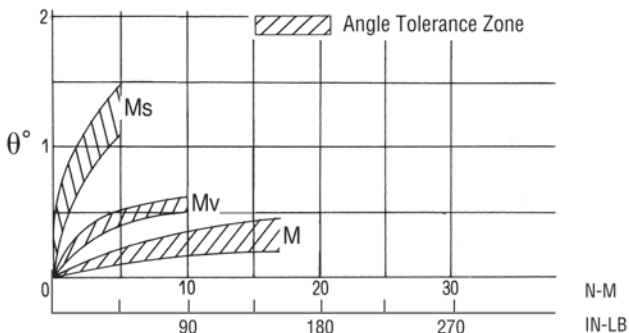

**63 mm Bore**

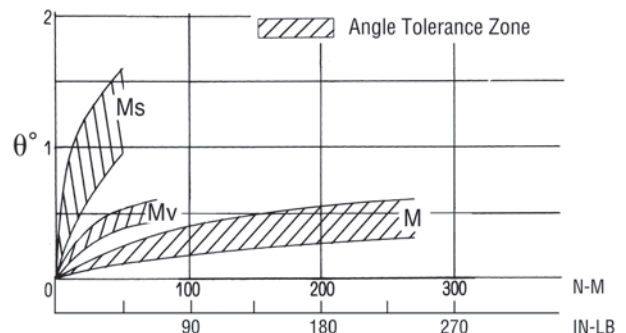

**G**

Rodless Pneumatic Cylinders

OSP-P Series

P1X Series

GDL Series



For inventory, lead times, and kit lookup, visit [www.pdnplu.com](http://www.pdnplu.com)

G95

**Parker Hannifin Corporation**  
 Pneumatic Division  
 Wadsworth, Ohio  
[www.parker.com/pneumatics](http://www.parker.com/pneumatics)

**Basic Cylinder**

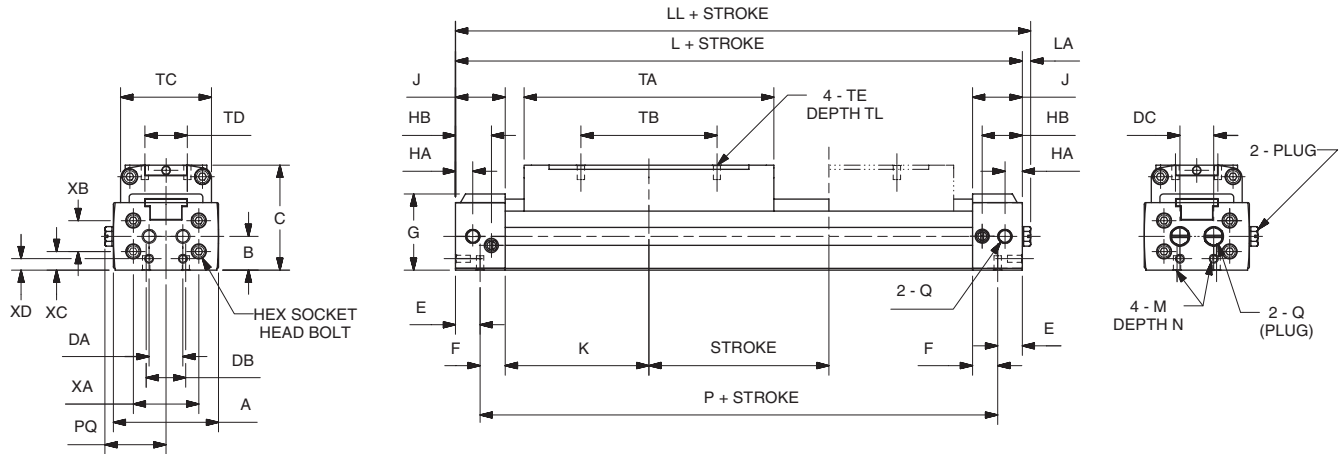

Bore (mm)	A	B	C	DA	DB	DC	E	F	G	HA	HB	J	K	L	LL	LA	M	N
16	1.46 (37)	0.47 (12)	1.46 (37)	0.47 (12)	0.55 (14)	0.47 (12)	0.34 (8.5)	0.35 (9)	1.06 (27)	0.24 (6)	0.55 (14)	0.69 (17.5)	2.24 (57)	5.87 (149)	5.98 (152)	0.12 (3)	5-40 (M3)	0.20 (5)
20	1.73 (44)	0.55 (14)	1.65 (42)	0.55 (14)	0.63 (16)	0.63 (16)	0.41 (10.5)	0.45 (11.5)	1.22 (31)	0.34 (8.5)	0.73 (18.5)	0.87 (22)	2.46 (62.5)	6.65 (169)	6.75 (171.5)	0.10 (2.5)	8-32 (M4)	0.26 (6.5)

Bore (mm)	P	PQ	Q	TA	TB	TC	TD	TE	TL	XA	XB	XC	XD
16	5.20 (132)	0.83 (21)	10-32 NPT (M5)	3.47 (88)	1.89 (48)	1.26 (32)	0.59 (15)	5-40 (M3)	0.20 (5)	0.91 (23)	0.43 (11)	0.26 (6.5)	0.16 (4)
20	5.83 (148)	0.97 (24.5)	1/8 NPT (1/8 Rc)	3.94 (100)	2.36 (60)	1.50 (38)	0.71 (18)	8-32 (M4)	0.24 (6)	1.10 (28)	0.63 (16)	0.24 (6)	0.20 (5)

inches (mm)

**G**  
 Rodless Pneumatic  
 Cylinders  
 OSP-P  
 Series  
 P1X  
 Series  
 GDL  
 Series



For inventory, lead times, and kit lookup, visit [www.pdnplu.com](http://www.pdnplu.com)

Basic Cylinder

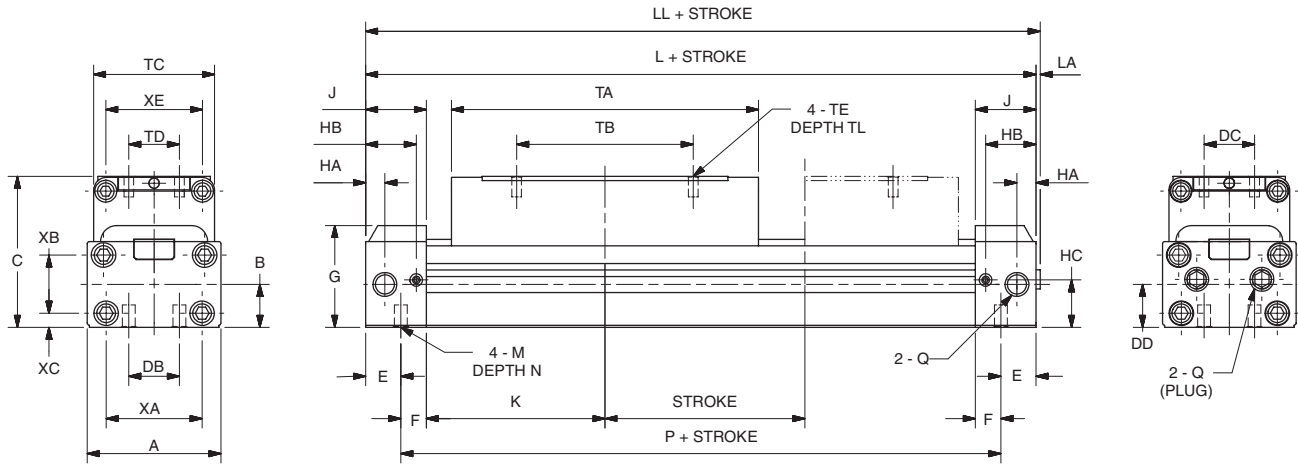

Bore (mm)	A	B	C	DB	DC	DD	E	F	G	HA	HB	HC	J	K	L	LL	LA	M	N
25	2.09 (53)	0.67 (17)	2.09 (53)	0.79 (20)	1.02 (26)	0.75 (19)	0.55 (14)	0.39 (10)	1.59 (40.5)	0.30 (7.5)	0.79 (20)	0.74 (18.9)	0.95 (24)	2.80 (71)	7.48 (190)	7.56 (192)	0.08 (2)	1/4-20 (M6)	0.35 (9)
32	2.60 (66)	0.73 (18.5)	2.24 (57)	1.26 (32)	1.06 (27)	0.83 (21)	0.59 (15)	0.51 (13)	1.71 (43.5)	0.39 (10)	0.93 (23.5)	0.85 (21.5)	1.10 (28)	3.35 (85)	8.90 (226)	9.00 (228.5)	0.10 (2.5)	1/4-20 (M6)	0.35 (9)
40	3.15 (80)	0.87 (22)	2.64 (67)	1.42 (36)	1.38 (35)	1.10 (28)	0.67 (17)	0.55 (14)	2.03 (51.5)	0.51 (13)	1.02 (26)	1.06 (27)	1.22 (31)	3.58 (91)	9.61 (244)	9.71 (246.5)	0.10 (2.5)	5/16-18 (M8)	0.47 (12)
50	3.78 (96)	1.10 (28)	3.23 (82)	1.77 (45)	1.38 (35)	1.38 (35)	0.91 (23)	0.63 (16)	2.40 (61)	0.59 (15)	1.30 (33)	1.39 (35.3)	1.54 (39)	3.54 (90)	10.16 (258)	10.26 (260.5)	0.10 (2.5)	5/16-18 (M8)	0.47 (12)
63	4.65 (118)	1.38 (35)	3.74 (95)	1.97 (50)	1.54 (39)	1.65 (42)	0.75 (19)	0.79 (20)	2.91 (74)	0.59 (15)	1.26 (32)	1.69 (43)	1.54 (39)	4.29 (109)	11.65 (296)	11.75 (298.5)	0.10 (2.5)	3/8-16 (M10)	0.59 (15)

Bore (mm)	P	Q	TA	TB	TC	TD	TE	TL	XA	XB	XC	XE
25	6.38 (162)	1/8 NPT (1/8 Rc)	4.80 (122)	2.76 (70)	1.89 (48)	0.79 (20)	10-24 (M5)	0.32 (8)	1.50 (38)	0.91 (23)	0.22 (5.5)	1.58 (40)
32	7.72 (196)	1/4 NPT (1/4 Rc)	5.28 (134)	3.15 (80)	2.21 (56)	0.79 (20)	1/4-20 (M6)	0.35 (9)	1.89 (48)	0.98 (25)	0.24 (6)	1.85 (47)
40	8.27 (210)	1/4 NPT (1/4 Rc)	5.83 (148)	3.54 (90)	2.68 (68)	1.18 (30)	1/4-20 (M6)	0.43 (11)	2.36 (60)	1.18 (30)	0.28 (7)	2.28 (58)
50	8.35 (212)	3/8 NPT (3/8 Rc)	5.98 (152)	3.94 (100)	3.15 (80)	1.18 (30)	5/16-18 (M8)	0.51 (13)	2.91 (74)	1.42 (36)	0.39 (10)	2.76 (70)
63	10.16 (258)	3/8 NPT (3/8 Rc)	6.61 (168)	4.33 (110)	4.02 (102)	1.58 (40)	5/16-18 (M8)	0.51 (13)	3.78 (96)	1.65 (42)	0.55 (14)	3.54 (90)

inches (mm)

**G**  
 Rodless Pneumatic Cylinders  
 OSP-P Series  
 P1X Series  
 GDL Series



For inventory, lead times, and kit lookup, visit [www.pdnplu.com](http://www.pdnplu.com)

G97

Parker Hannifin Corporation  
Pneumatic Division  
Wadsworth, Ohio  
[www.parker.com/pneumatics](http://www.parker.com/pneumatics)

**End Mount Foot Bracket**

16 to 32 mm bore sizes

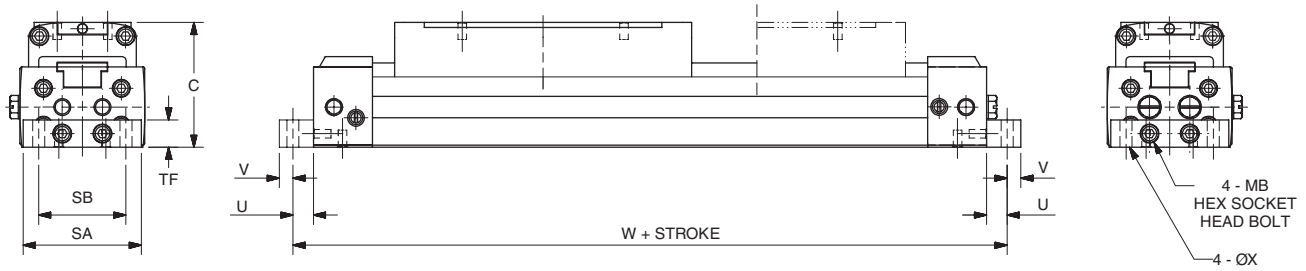

40 to 63 mm bore sizes

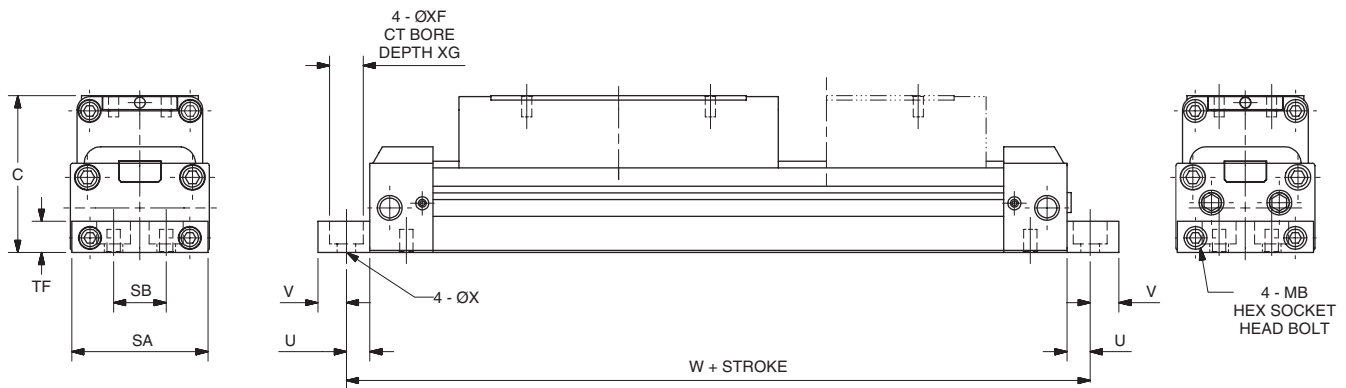

Bore (mm)	C	SA	SB	TF	U	V	W	X	XF	XG	MB
16	1.46 (37)	1.38 (35)	1.02 (26)	0.32 (8)	0.24 (6)	0.16 (4)	6.34 (161)	0.14 (3.6)	—	—	M3x10
20	1.65 (42)	1.69 (43)	1.30 (33)	0.39 (10)	0.24 (6)	0.24 (6)	7.13 (181)	0.19 (4.7)	—	—	M4x12
25	2.09 (53)	2.05 (52)	0.79 (20)	0.47 (12)	0.35 (9)	0.43 (11)	8.19 (208)	0.28 (7)	—	—	M5x50
32	2.24 (57)	2.52 (64)	1.26 (32)	0.47 (12)	0.35 (9)	0.43 (11)	9.61 (244)	0.28 (7)	—	—	M5x50
40	2.64 (67)	3.15 (80)	1.42 (36)	0.59 (15)	0.49 (12.5)	0.45 (11.5)	10.60 (269)	0.35 (9)	0.51 (13)	0.34 (8.7)	M6x55
50	3.23 (82)	3.70 (94)	1.77 (45)	0.79 (20)	0.49 (12.5)	0.45 (11.5)	11.10 (283)	0.35 (9)	0.51 (13)	0.34 (8.7)	M8x65
63	3.74 (95)	4.57 (116)	1.97 (50)	0.98 (25)	0.59 (15)	0.59 (15)	12.80 (326)	0.43 (11)	0.61 (15.5)	0.41 (10.5)	M8x70

inches (mm)

**G**  
 Rodless Pneumatic  
 Cylinders  
 OSP-P  
 Series  
 P1X  
 Series  
 GDL  
 Series



For inventory, lead times, and kit lookup, visit [www.pdnplu.com](http://www.pdnplu.com)

Bottom Mount Foot Bracket

16 to 20 mm bore sizes

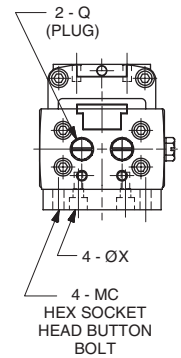
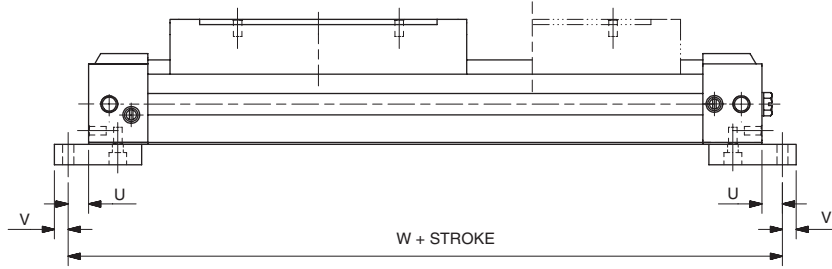
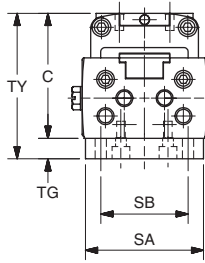

25 to 32 mm bore sizes

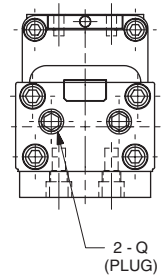
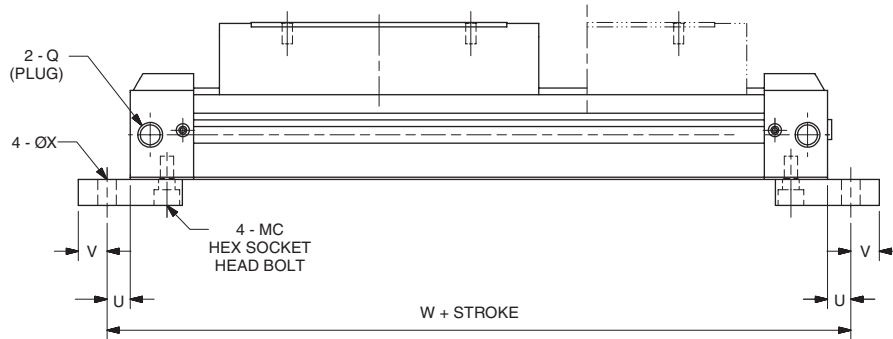
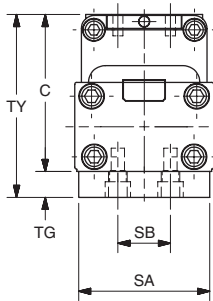

Bore (mm)	C	Q	SA	SB	TG	TY	U	V	W	X	MC
16	1.46 (37)	10-32 (M5)	1.38 (35)	1.02 (26)	0.24 (6)	1.69 (43)	0.24 (6)	0.16 (4)	6.34 (161)	0.13 (3.4)	5-40, 1/4 LG
20	1.65 (42)	1/8 NPT (1/8 Rc)	1.69 (43)	1.30 (33)	0.32 (8)	1.97 (50)	0.24 (6)	0.24 (6)	7.13 (181)	0.18 (4.5)	8-32, 3/8 LG
25	2.09 (53)	1/8 NPT (1/8 Rc)	1.97 (50)	0.79 (20)	0.39 (10)	2.48 (63)	0.35 (9)	0.43 (11)	8.19 (208)	0.28 (7)	1/4-20 x 1/2 LG
32	2.24 (57)	1/4 NPT (1/4 Rc)	2.52 (64)	1.26 (32)	0.39 (10)	2.64 (67)	0.35 (9)	0.43 (11)	9.61 (244)	0.28 (7)	1/4-20 x 1/2 LG
40	2.64 (67)	1/4 NPT (1/4 Rc)	-	-	-	-	-	-	-	-	-
50	3.23 (82)	3/8 NPT (3/8 Rc)	-	-	-	-	-	-	-	-	-
63	3.74 (95)	3/8 NPT (3/8 Rc)	-	-	-	-	-	-	-	-	-

inches (mm)



Rodless Pneumatic Cylinders

OSP-P Series

P1X Series

GDL Series



For inventory, lead times, and kit lookup, visit [www.pdnplu.com](http://www.pdnplu.com)

G99

Parker Hannifin Corporation  
Pneumatic Division  
Wadsworth, Ohio  
[www.parker.com/pneumatics](http://www.parker.com/pneumatics)

**Intermediate support brackets (2 per kit)**

**End mount**

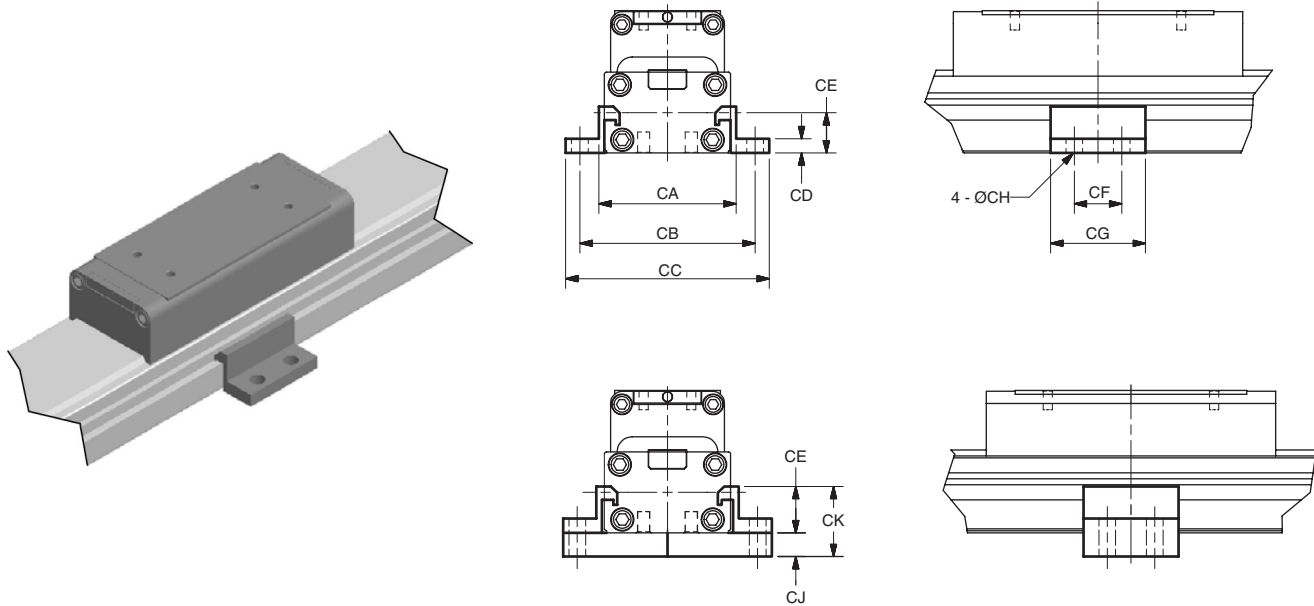

Bore (mm)	CA	CB	CC	CD	CE	CF	CG	CH
16	1.654 (42)	2.205 (56)	2.52 (64)	0.118 (3)	0.472 (12)	0.787 (20)	1.378 (35)	0.157 (4)
20	1.929 (49)	2.52 (64)	2.953 (75)	0.157 (4)	0.551 (14)	0.787 (20)	1.496 (38)	0.197 (5)
25	2.362 (60)	2.992 (76)	3.465 (88)	0.236 (6)	0.768 (19.5)	0.787 (20)	1.575 (40)	0.276 (7)
32	2.913 (74)	3.465 (88)	3.937 (100)	0.236 (6)	0.846 (21.5)	0.787 (20)	1.575 (40)	0.276 (7)
40	3.543 (90)	4.252 (108)	4.882 (124)	0.236 (6)	0.965 (24.5)	1.181 (30)	2.362 (60)	0.354 (9)
50	4.173 (106)	4.882 (124)	5.512 (140)	0.315 (8)	1.201 (30.5)	1.181 (30)	2.362 (60)	0.354 (9)
63	5.118 (130)	5.984 (152)	6.772 (172)	0.394 (10)	1.516 (38.5)	1.969 (50)	3.543 (90)	0.433 (11)

Bore (mm)	CJ	CK	Kit Part Number	
			End Mount or No Mount	Bottom Mount
16	0.236 (6)	0.709 (18)	<b>L080180016</b>	<b>L080190016</b>
20	0.315 (8)	0.866 (22)	<b>L080180020</b>	<b>L080190020</b>
25	0.394 (10)	1.161 (29.5)	<b>L080180025</b>	<b>L080190025</b>
32	0.394 (10)	1.24 (31.5)	<b>L080180032</b>	<b>L080190032</b>
40	—	—	<b>L080180040</b>	
50	—	—	<b>L080180050</b>	
63	—	—	<b>L080180063</b>	

inches (mm)

**G**  
 Rodless Pneumatic Cylinders  
 OSP-P Series  
 P1X Series  
 GD L Series



For inventory, lead times, and kit lookup, visit [www.pdnplu.com](http://www.pdnplu.com)

G100

**Parker Hannifin Corporation**  
 Pneumatic Division  
 Wadsworth, Ohio  
[www.parker.com/pneumatics](http://www.parker.com/pneumatics)

**Swivel mount**

Absorbs misalignment between cylinder and load

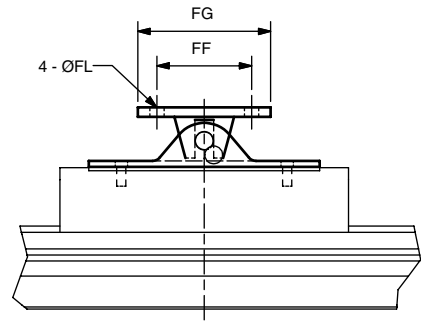
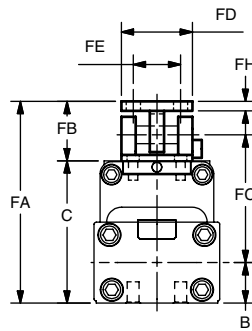
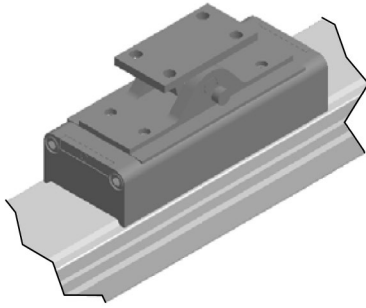

FJ dimension is the maximum horizontal float

FK dimension is the maximum vertical float

Bore (mm)	FA	FB	FC	FD	FE	FF	FG	FH
16	2.238 (58)	0.827 (21)	1.339 (34)	0.945 (24)	0.673 (16)	1.181 (30)	1.575 (40)	0.118 (3)
20	2.638 (67)	0.984 (25)	1.535 (39)	1.181 (30)	0.787 (20)	1.575 (40)	2.205 (56)	0.157 (4)
25	3.071 (78)	0.984 (25)	1.85 (47)	1.181 (30)	0.787 (20)	1.575 (40)	2.205 (56)	0.157 (4)
32	3.74 (95)	1.496 (38)	2.185 (55.5)	1.772 (45)	1.181 (30)	1.969 (50)	2.756 (70)	0.236 (6)
40	4.134 (105)	1.496 (38)	2.441 (62)	1.772 (45)	1.181 (30)	1.969 (50)	2.756 (70)	0.236 (6)
50	4.961 (126)	1.732 (44)	2.874 (73)	2.362 (60)	1.575 (40)	2.756 (70)	3.543 (90)	0.315 (8)
63	5.472 (139)	1.732 (44)	3.11 (79)	2.362 (60)	1.575 (40)	2.756 (70)	3.543 (90)	0.315 (8)

Bore (mm)		FJ	FK	FL	B	C	Part Number
16	inches	0.118	0.118	0.134	0.472	1.457	L078930016
	mm	3	3	3.4	12	37	L078930016
20	inches	0.118	0.118	0.177	0.551	1.654	L080160020
	mm	3	3	4.5	14	42	L08016M020
25	inches	0.118	0.118	0.236	0.669	2.087	L080160025
	mm	3	3	6	17	53	L08016M025
32	inches	0.197	0.197	0.276	0.728	2.244	L080160032
	mm	5	5	7	18.5	57	L08016M032
40	inches	0.197	0.197	0.276	0.866	2.638	L080160040
	mm	5	5	7	22	67	L08016M040
50	inches	0.197	0.197	0.354	1.102	3.228	L080160050
	mm	5	5	9	28	82	L08016M050
63	inches	0.197	0.197	0.354	1.378	3.74	L080160063
	mm	5	5	9	35	95	L08016M063

inches (mm)

**G**  
 Rodless Pneumatic Cylinders  
 OSP-P Series  
 P1X Series  
 GDL Series



For inventory, lead times, and kit lookup, visit [www.pdnplu.com](http://www.pdnplu.com)

G101

Parker Hannifin Corporation  
 Pneumatic Division  
 Wadsworth, Ohio  
[www.parker.com/pneumatics](http://www.parker.com/pneumatics)

**End Port Piping**

Refer to chart below to determine when end port piping can be used with various types of mountings relative to fitting clearance.

On all bore sizes with foot mounting, the end port pipe fittings will obstruct the mounting holes. To avoid this problem, mount the cylinder first and tighten the mounting bolts and then attach the pipe fittings to the cylinder ports.

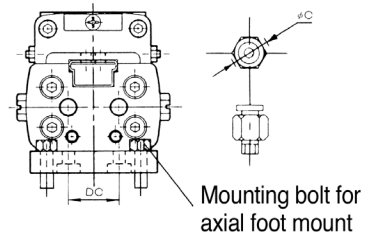

Bore (mm)	øC [O.D. of fittings - mm (in.)]		
	No Mount	End Mount	Bottom Mount
16	12 (0.472)		12 (0.472)
20	16 (0.630)	End Port Piping	16 (0.630)
25	26 (1.024)	Not Available	26 (1.024)
32	27 (1.065)		27 (1.063)
40	35 (1.378)	26 (1.024)	
50	35 (1.378)	30 (1.181)	
63	39 (1.535)	34 (1.339)	

**G**

Rodless Pneumatic Cylinders

OSP-P Series

P1X Series

GDL Series



## Shock Absorbers Selection Criteria

### The Shock Absorber Advantage

- Increase equipment throughput
- Smoother deceleration of loads
- Adjustable end of stroke positioning
- Prevents impact damage
- Minimize shock loads on equipment
- Improves product performance

### Four Steps to Great Performance

#### Step 1. Gather the Application Parameters

- Total load weight (pounds)
- Final velocity at impact (inches/second)\*
- Cycle rate (cycles per hour)

#### Step 2. Verify Shock Absorber Performance

- See charts on the following pages
- Determine that shock absorber will do the job

#### Step 3. Verify the Cycle Rate

- See shock specifications below and verify application is within cycle rate

#### Step 4. Choose the Appropriate Option in Model Code

\*If final velocity cannot be easily calculated, double the average velocity.

### Shock absorber specifications

Cylinder	16mm	20mm	25mm	32mm	40mm	50, 63mm
<b>Shock Absorber Number</b>	<b>109556</b>	<b>109559</b>	<b>109560</b>	<b>109561</b>	<b>109562</b>	<b>MC600MH</b>
Max. energy absorption - in-lbs (kgf-m)	26.0 (0.3)	60.8 (0.7)	104.2 (1.2)	226 (2.6)	608 (7.0)	1042 (12)
Stroke - inches	0.236	0.315	0.394	0.590	0.787	0.984
Energy absorption / hour - in.-lbs / hour	54,700	109,380	187,510	338,560	729,200	750,000
Max. impact velocity - in. / sec.	59	59	78.7	78.7	98.4	118.1
Max. cycle rate per hour	2100	1800	1800	1500	1200	720
Ambient temperature - °F (°C)	41-140 (5-60)					
Spring return force - lb. Extended	0.65	0.45	0.65	1.33	2.20	3.60
Compressed	1.01	0.97	1.33	2.65	4.86	7.49
Return time - Sec.	0.3	0.3	0.3	0.3	0.4	0.4



Rodless Pneumatic Cylinders

OSP-P Series

P1X Series

GDL Series



For inventory, lead times, and kit lookup, visit [www.pdnplu.com](http://www.pdnplu.com)

G103

**Parker Hannifin Corporation**  
 Pneumatic Division  
 Wadsworth, Ohio  
[www.parker.com/pneumatics](http://www.parker.com/pneumatics)

**Performance data (16 to 32mm bores)**

**16 mm Bore**

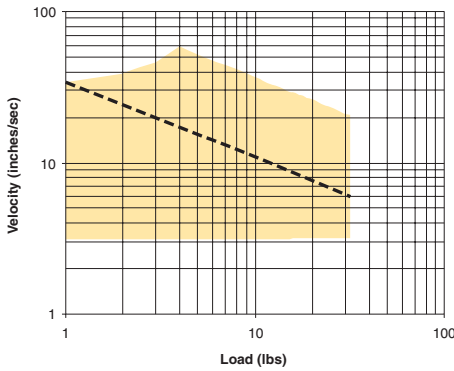

--- Air Cushion w/back pressure (flow controls or other meter out device)  
 Shock Absorber

- Notes:**
1. If the cylinder is vertical in orientation, double the total load for bottom shock absorber.
  2. Use the total load that is being moved by shock absorber. In a weight transfer application, this would include  $L_a$ .
  3. If final velocity cannot be easily determined, use two times the stroke divided by the stroke time.

**20 mm Bore**

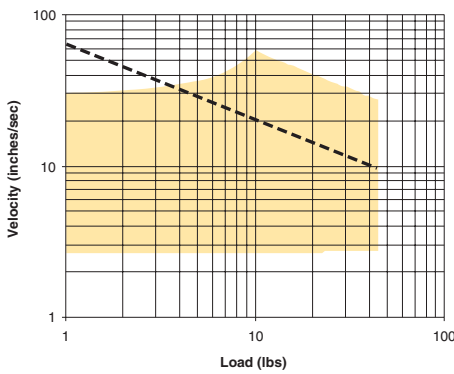

**40 mm Bore**

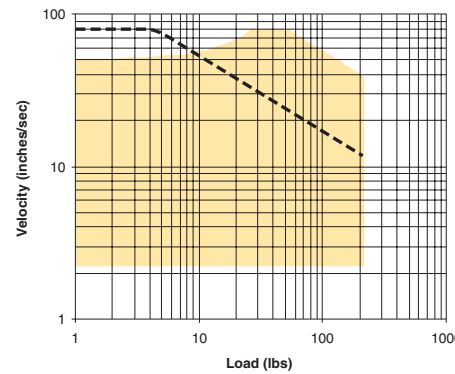

**25 mm Bore**

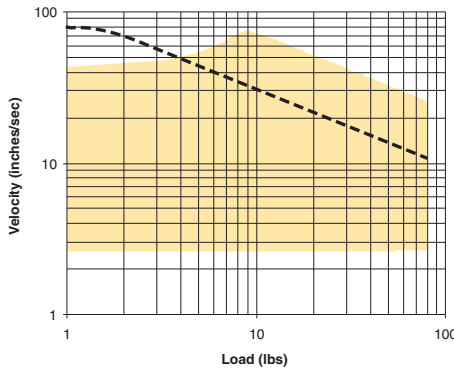

**50 mm Bore**

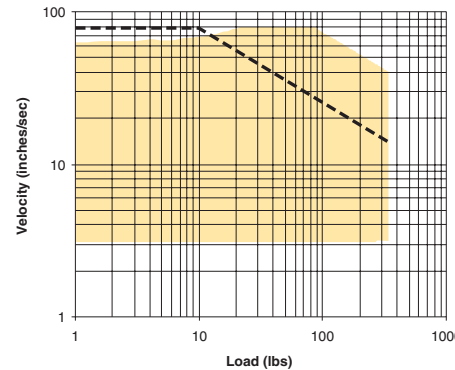

**32 mm Bore**

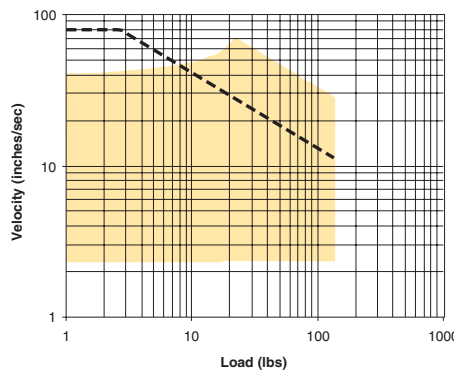

**63 mm Bore**

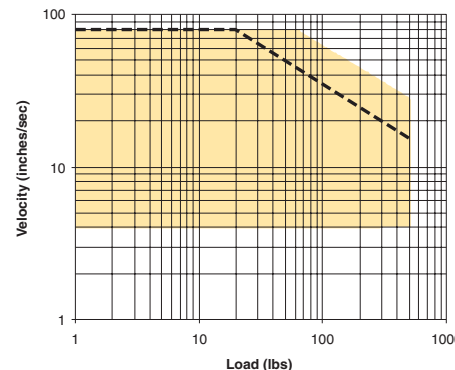

**G**  
 Rodless Pneumatic Cylinders  
 OSP-P Series  
 P1X Series  
 GDL Series



For inventory, lead times, and kit lookup, visit [www.pdnplu.com](http://www.pdnplu.com)

**Stroke Adjustments and Shock Absorber Dimensions**

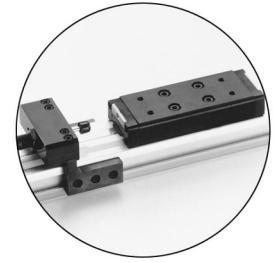

**16 to 25mm bore sizes**

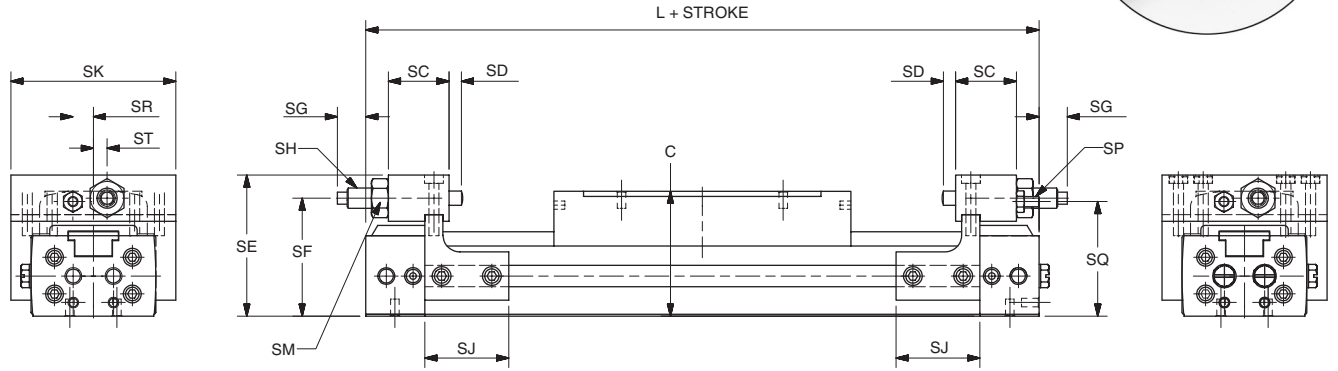

Bore (mm)	SC	SD	SE	SF	SG		SH in-lbs	SJ	SK	SP	SQ	SR	ST	C	L
					Max	Min									
16	0.71 (18)	0.16 (4)	1.65 (42)	1.38 (35)	0.57 (14.5)	0.18 (4.5)	26	0.98 (25)	1.93 (49)	M3	1.34 (34)	0.24 (6)	0.16 (4)	1.46 (37)	5.87 (149)
20	0.89 (22.5)	0.14 (3.5)	1.89 (48)	1.57 (40)	0.57 (14.5)	0.18 (4.5)	61	1.54 (39)	2.24 (57)	M4	1.50 (38)	0.32 (8)	0.20 (5)	1.65 (42)	6.65 (169)
25	0.79 (20)	0.10 (2.5)	2.46 (62.5)	2.03 (51.5)	0.57 (14.5)	0.18 (4.5)	104	1.97 (50)	3.03 (77)	M6	1.97 (50)	0.47 (12)	0.39 (10)	2.09 (53)	7.48 (190)

inches (mm)  
 SH = max. energy absorption

**32 to 63mm bore sizes**

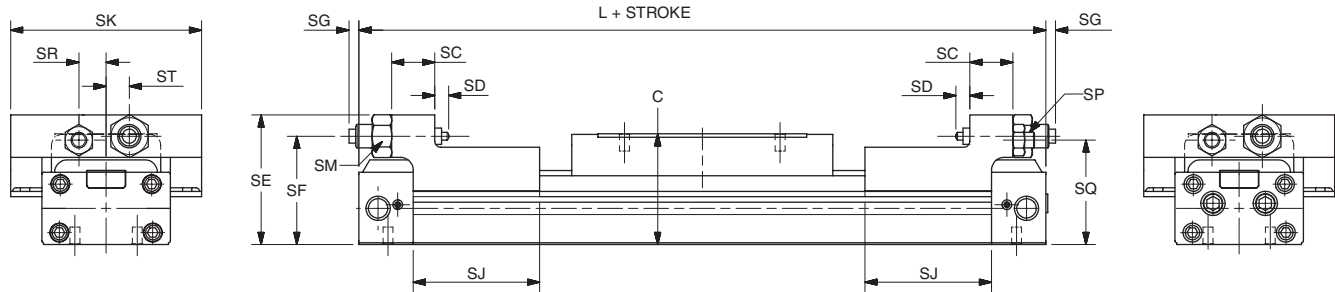

Bore (mm)	SC	SD	SE	SF	SG		SH in-lbs	SJ	SK	SP	SQ	SR	ST	C	L
					Max	Min									
32	0.87 (22)	0.28 (7)	2.62 (66.5)	2.19 (55.5)	1.06 (27)	0.67 (17)	226	2.56 (65)	3.86 (98)	M8	2.11 (53.5)	0.55 (14)	0.47 (12)	2.24 (57)	8.90 (226)
40	1.26 (32)	0.28 (7)	3.09 (78.5)	2.58 (65.5)	1.34 (34)	0.94 (24)	608	2.56 (65)	4.41 (112)	M10	2.50 (63.5)	0.67 (17)	0.47 (12)	2.64 (67)	9.61 (244)
50	1.50 (38)	0.32 (8)	3.90 (99)	3.15 (80)	2.17 (55)	1.77 (45)	1042	2.76 (70)	5.35 (136)	M12	3.05 (77.5)	0.87 (22)	0.67 (17)	3.23 (82)	10.16 (258)
63	1.50 (38)	0.32 (8)	4.41 (112)	3.68 (93.5)	1.73 (44)	1.34 (34)	1042	2.76 (70)	6.22 (158)	M16	3.50 (89)	0.98 (25)	0.79 (20)	3.74 (95)	11.65 (296)

inches (mm)  
 SH = max. energy absorption



For inventory, lead times, and kit lookup, visit [www.pdnplu.com](http://www.pdnplu.com)

G105

**Parker Hannifin Corporation**  
 Pneumatic Division  
 Wadsworth, Ohio  
[www.parker.com/pneumatics](http://www.parker.com/pneumatics)



**Rodless Pneumatic Cylinders**

**OSP-P Series**

**P1X Series**

**GDL Series**

**Positioning of stroke adjustment unit**

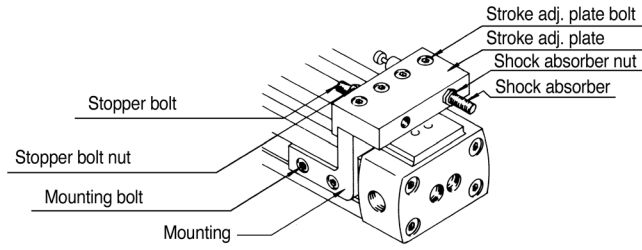

**ø16-ø25**

- (1) Moving the stroke adjustment unit.  
 The stroke adjustment unit can be moved by loosening the mounting bolts.
- (2) Locking of stroke adjustment unit.  
 After moving the stroke adjustment unit to the appropriate position, lock it there by tightening the mounting bolts to the torque values shown in Figure 1. Insufficient torque may cause the stroke adjustment unit to slip out of position.

**Figure 1**  
**Torque values for tightening stroke adjustment unit.**

Bore Size	Tightening Torque	
	Mounting Bolt (lb-in)	Stroke adj. Plate Bolt (lb-in)
16mm	9-11	4-6
20mm	22-24	
25mm	46-50	22-24
32mm	195-213	-
40mm	390-415	-
50, 63mm	682-735	-

- (3) Stroke adjustment using the stopper bolt.  
 Adjust the stroke by loosening the stopper bolt nut and turning the stopper bolt. After adjusting the stroke, tighten the stopper bolt nut to the torque values shown in Figure 2. When adjusting the 16-25 mm cylinders, due to the small amount of clearance between the table and the stroke adjustment plate, adjust the stroke by moving the complete stroke adjustment unit.

**Figure 2**  
**Torque values for tightening stopper bolt nut and shock absorber nut.**

Bore Size	Tightening Torque	
	Stopper Bolt Nut (lb-in)	Shock Absorber Nut (lb-in)
16mm	10-11	12-16
20mm	22-24	26-35
25mm	73-84	40-53
32mm	195-213	66-89
40mm	390-425	195-266
50mm	682-735	487-620
63mm	1772-1914	487-620

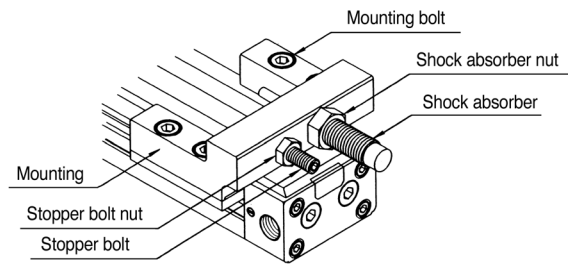

**ø32-ø63**

- (4) Adjustment of shock absorber.  
 Adjust the absorption energy of the shock absorber by changing the operating stroke of the shock absorber. This is done by loosening the shock absorber nut and turning the unit. When adjustment is complete, tighten the shock absorber nut to the torque values shown in Figure 2.
- (5) Notes on usage.  
 The shock absorber absorbs rated energy with rated stroke. The factory setting allows a small amount of shock absorber stroke before it bottoms out. Readjust the location of the shock absorber so that the complete stroke of the absorber is utilized.

Absorption energy as set at factory:  
 Small margin with stroke of shock absorber.

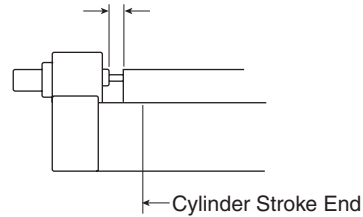

Adjust the position of the shock absorber until the plunger of the shock absorber is fully depressed.

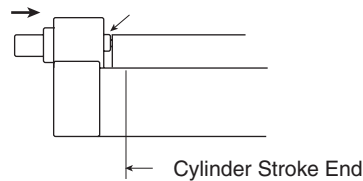

**GDL Series**

**Light, Smooth and FAST**

Aluminum roller guides in a cutting machine for spectacle lenses. Both the work piece carriers and the motorized X - Y table axis are equipped with roller guides. The smooth operation and precision of the equipment ensures a fine cutting action.

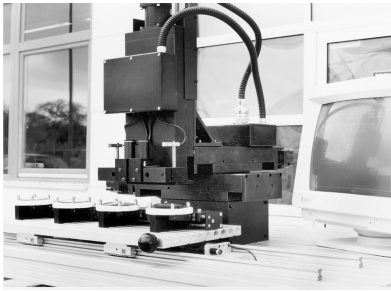

- Light weight (anodized aluminum)
- Smooth and quiet operation
- Speeds up to 10 m/s
- Acceleration/deceleration up to 40 m/s<sup>2</sup>
- Loading from any direction
- Permanently lubricated guidance system
- Broad product range in various series high performance, standard and stainless steel versions
- High load and moment capacities
- Very cost effective
- Flexible mounting dimensions

Aluminum roller guides in an automatic vibrator for flattening printed sheets of paper. To guarantee even pressure on the sheets of paper, the roller bridge is supported by precision roller guides.

(Baumann company photo)

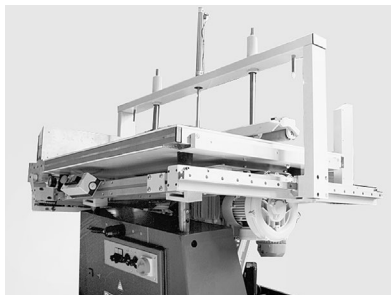

Handling units for medical equipment. Smooth, easy movement with guideline roller guides.

(Dräger company photo)



Aluminum roller guides in the sliding carriage of a machine for producing cables. The projecting arm of the carriage is guided by two double rails each with two roller cassettes and can be moved manually with minimal force because of the low friction properties.

(Kabelmat company photo)

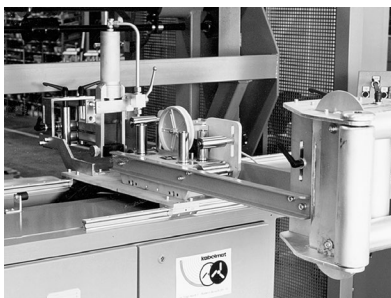

Single rail and roller shoe versions of the aluminum roller guide in a handling arrangement for stacks of paper. Various fittings and limit stops for stacking are moved on two axes horizontally and vertically. The robustness and reliability of the roller guides allows for continuous operation under high load conditions.

(Solms company photo)

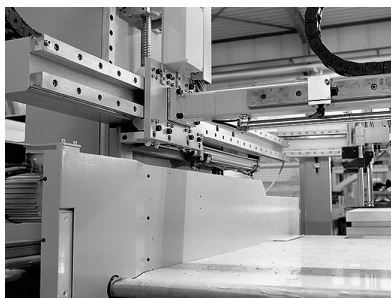

<b>G</b>
<b>Rodless Pneumatic Cylinders</b>
<b>OSP-P Series</b>
<b>P1X Series</b>
<b>GDL Series</b>



For inventory, lead times, and kit lookup, visit [www.pdnplu.com](http://www.pdnplu.com)

G107

**Parker Hannifin Corporation**  
Pneumatic Division  
Wadsworth, Ohio  
[www.parker.com/pneumatics](http://www.parker.com/pneumatics)

## GDL Linear Guides Offer a Variety of Series and Options – High Performance... “Smooth Guidance”

Aluminum roller guides provide smooth operation and high load carrying capacity for industrial automation.

By the use of lightweight aluminum components the moving masses are minimized, travel speeds are increased and actuation energy is saved.

Aluminum roller guides are designed to carry medium weight loads economically. Their smooth action and speeds up to 10 m/s make them ideal for widespread use in many areas of application.

Aside from a main featured High Performance guide, others such as the Standard, Corrosion Resistant, High Dynamics and Grease-free versions are also available.

Aluminum roller guides are available in sizes 12, 15, 20, 25, 35 and 45mm. Rail lengths are from 200 mm to 4000 mm. For longer travel lengths, guide rails can be butt-jointed together.

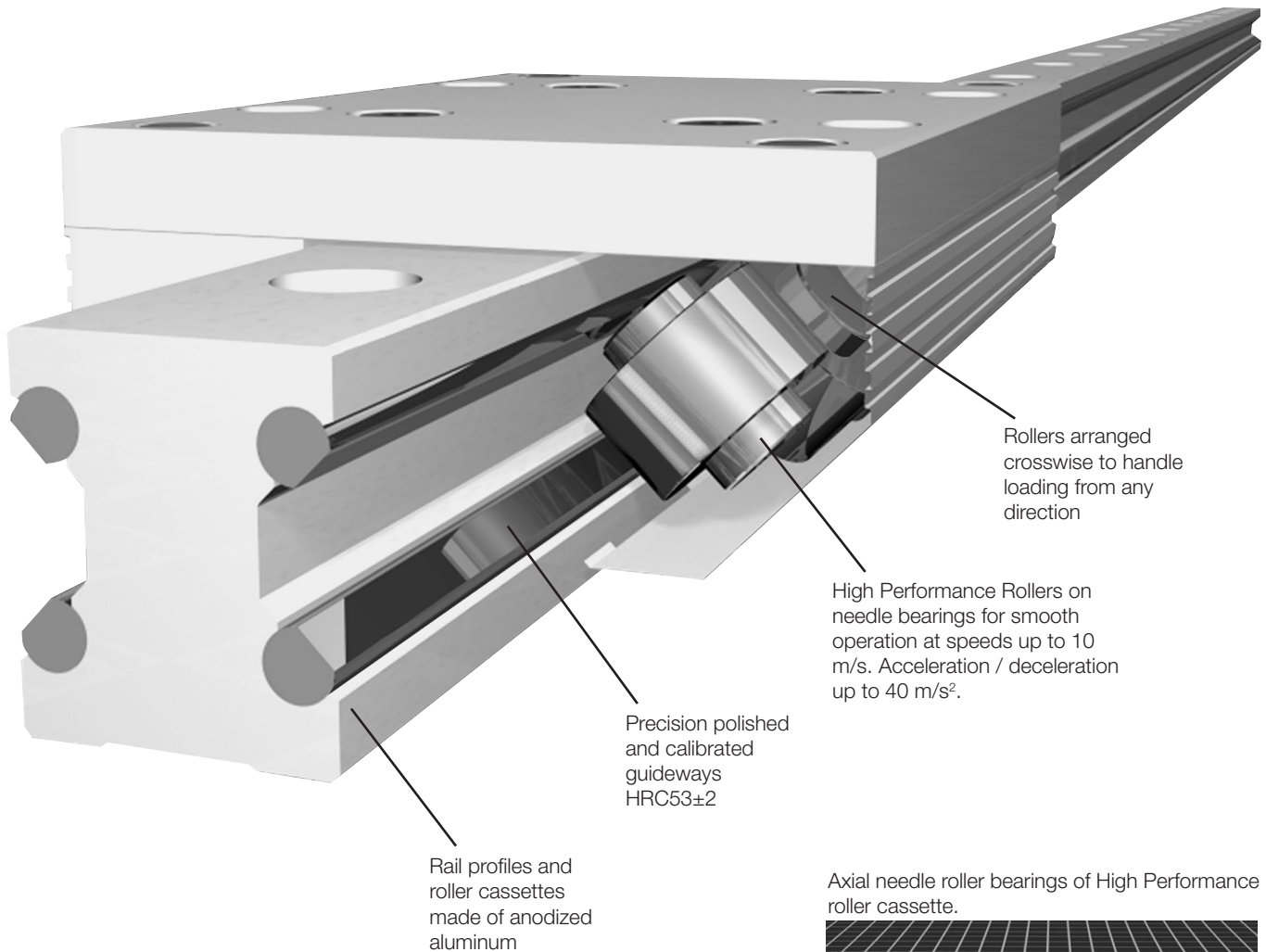

Axial needle roller bearings of High Performance roller cassette.

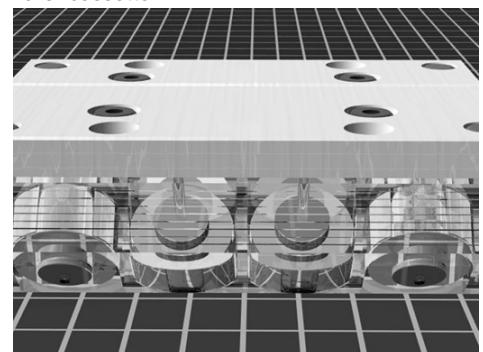

<b>G</b>
Rodless Pneumatic Cylinders
OSP-P Series
P1X Series
GDL Series



For inventory, lead times, and kit lookup, visit [www.pdnplu.com](http://www.pdnplu.com)



**Ordering Information**

**High Performance Series:**

(Sizes FDC12HP-... thru FDC45HP-...)

The High Performance series is the basis for GDL's development, which is used in the majority of applications. High Performance guides consist of 8 axial needle roller bearings, running on precision polished and hardened alloy spring steel guideways. These guide bearings are grease packed and shielded, while offering the highest load and moment rating capacities within the GDL product line.

**Standard Performance Series:**

(Sizes FDC12SP-... thru FDC45SP-...)

The Standard Performance series is intended for minor loads and moments for particularly economical guidance solutions. Standard Performance guides consist of 8 radial ball roller bearings, running on precision polished and hardened alloy spring steel guideways. These guide bearings are grease packed and sealed, while offering the lowest load and moment ratings available within the GDL product line, with the exception of the Grease-Free and the Anti-Friction / Corrosion Resistant series. Standard Performance series is the second most commonly used GDL guides for various applications and also provides excellent running behavior.

**Ordering Information for GDL Rails**

1	2	3	4	5	6	7	8	9	10	11	12	13	14	15	16	17	18
F	D	R	1	2	H	0	0	0	0	0	0	-	0	0	0	0	0
<b>Series</b>		<b>Rail Size</b>		<b>"L11" Dimension</b>				<b>Length (mm)</b>									
FD Double Sided Rail Guide* (standard)		1 2* 1 5* 2 0* 2 5* 3 5* 4 5*		00 Equal on Both Sides* (standard) ?? Actual Dimension (mm)**				- 0 0 0 0 0									
<b>Rail</b>		<b>Guideway Material</b>		<b>Mounting Holes</b>				<b>Screw Covers</b>									
R Standard		H High Performance Alloy Steel* (standard) S Stainless Steel		0 Topside Thru Hole* (standard) 1 Underside Blind Thread Z Custom (consult factory)				0 None* (standard) 1 Yes*									
<b>Coatings</b>		<b>Long Rail Joining Option</b>		<b>Lubrication Options</b>				<b>Locking Mechanism</b>									
0 Anodized Aluminum* (standard)		0 None* (standard) 1 Keyed Butt Joint (size 25-45 only) 2 Unkeyed Butt Joint		0 None* (standard) 1 Central Lube 2 Central Lube (no nipple) Z Custom (consult factory)**				0 None* (standard) 1 "L" Ratchet Handle* 2 Star Grip Handle*									
*Stocked Item		**As measured from left side while viewing the depth groove line.		* Locking mechanism only available on FD Series size 15 thru 45 with Axial Needle Bearing - High Performance - Alloy Steel.				Note: Maximum length is 4 meters on Size 12. Note: Quantity supplied to cover all rail holes.									

**Ordering Information for GDL Cassettes**

1	2	3	4	5	6	7	8	9	10	11	12	13	14	15	16
F	D	C	1	2	H	P	-	0	0	0	0	0	0	0	0
<b>Series</b>		<b>Rail Size</b>		<b>Grease</b>				<b>Mounting Holes</b>							
FD Double Sided Rail Cassette* (standard)		1 2* 1 5* 2 0* 2 5* 3 5* 4 5*		0 High Performance* (standard) Z Custom (consult factory)				0 Topside Threaded Thru* (standard) 1 Underside Hole Thru (unthreaded) 2 Underside Hole Thru (threaded)							
<b>Cassette</b>		<b>Bearing Options</b>		<b>Lubrication Options</b>				<b>Adjustment</b>							
C Standard		AM Non-Magnetic (bearing only) HC Axial Needle - High Performance Alloy Steel, Non-Corrosive* HP Axial Needle - High Performance Alloy Steel* (standard) SP Single Row Radial Ball - Standard Performance - Alloy Steel* (standard) ZZ Factory** (consult factory) GF Grease free		0 None* (standard) 1 Central Lube 2 Central Lube (no nipple) Z Custom (consult factory)**				0 None* (standard) 1 Adjusted to Specific Rail*							
<b>Coatings</b>		<b>Cassette Length</b>		<b>Coatings</b>				<b>Wiper Options</b>							
0 Anodized and Standard Hardware* (standard) 1 Anodized and Stainless Steel Hardware* Z Custom (consult factory)		0 Normal Length* (standard) Z Custom (consult factory)**		0 Anodized and Standard Hardware* (standard) 1 Anodized and Stainless Steel Hardware* Z Custom (consult factory)				0 With Felt Wipers* (standard) 1 Without* 2 With Felt Wipers and Scrapers*							
*Stocked Item **Minimum Order Quantity Required		* Locking mechanism only available on FD Series size 15 thru 45 with Axial Needle Bearing - High Performance - Alloy Steel.													



For inventory, lead times, and kit lookup, visit [www.pdnplu.com](http://www.pdnplu.com)

G109

Parker Hannifin Corporation  
Pneumatic Division  
Wadsworth, Ohio  
[www.parker.com/pneumatics](http://www.parker.com/pneumatics)

G

Rodless Pneumatic Cylinders

OSP-P Series

P1X Series

GDL Series



**Product Line Overview**

Characteristic	Unit	Description
Full profile wipers		Rollershoes and cassette are provided with snap-on full profile wipers. The snap-on full profile wipers are easily replaceable with available wipers kits.
Acceleration and deceleration	m/s <sup>2</sup> (ft/sec <sup>2</sup> )	40 m/s <sup>2</sup> maximum (131 ft/s <sup>2</sup> maximum)
Guide installation		Possible in any position.
Drag adjustment set screw		Cassettes can be adjusted at the factory or by the customer. Rollershoes can be set-up by the customer to incorporate the drag adjustment set screw feature. The drag adjustment set screw components are supplied with each pair of rollershoes.
Standard lubrication		Lifetime lubrication with standard grease-packed roller bearings.
Speed	m/s (ft/s)	Up to 10 m/s (or up to 33 ft/s)
Bearing types		Steel axial needle, Specials on request (ex: anti-magnetic, grease free, high dynamics) - consult factory
Operating temperature	C (F)	-10°C to 80°C (14°F to 176°F) temperature range
Specials available		Custom length cassettes and rollershoes for 100 piece lots minimum. Keyed butt-jointed rail sections for continuous rail lengths of 3900mm and above. Solid continuous length rails up to 3900mm. Offset or non-standard "L11" dimensions on opposite ends of cut rails. Integrated metal scraper with standard full profile wiper currently available. Rail underside blind mounting holes.

**Material specifications**

Rail		Aluminum alloy
Guideways	Standard	Steel alloy 62661B-steel
	Corrosive resistant	Stainless alloy 62661N
Cassettes / rollershoes / top plates		Aluminum alloy
Rollers		Bearing steel / Stainless steel bearing steel

**General Facts Pertaining to All Series:**

Snap-on full profile wipers:	Rollershoes and cassettes can be provided with snap-on full profile wipers. The snap-on full profile wipers are easily replaceable with available wiper kits. See page G114 for respective wiper kit part numbers.
Cassette adjustment:	Cassettes can be adjusted at the factory or by the customer.
Fasteners:	Rollershoes and cassettes use ISO screw quality 8.8 and DIN 433 washers. ISO screw quality 8.8 is recommended for mounting the rails also. Special stainless steel fasteners can be requested as necessary.
Carrying Capacity:	See load and moment rating tables on next page for your guide series of interest.
Guide mounting position:	Optional.
Lengths:	For longer than standard rail lengths, see keyed butt-jointed rail option on page G114.
Lubrication:	GDL Aluminum Roller Guides are permanently lubricated with contained roller bearings grease.

See ordering information on previous page to define your desired GDL guide features for ordering.

**G**  
 Rodless Pneumatic Cylinders  
 OSP-P Series  
 P1X Series  
 GDL Series



For inventory, lead times, and kit lookup, visit [www.pdnplu.com](http://www.pdnplu.com)



**Cassette with double sided rail**

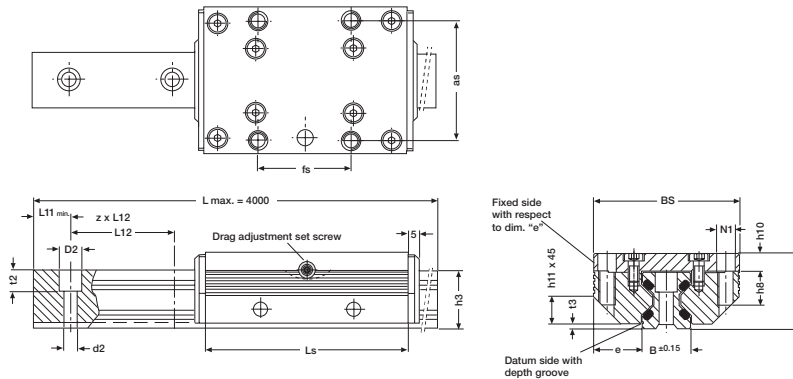

**Both standard FDC version guides**

Size	Length										L11							
	Ls	B	BS	h3	h9	as	d2	D2	e	fs	h8	h10	h11	min.	L12	t2	t3	N1
12	64	12.0	37	14.7	19	30	3.4	6	12.50	25	8	4.0	6	10	40	5.5	1.4	M4
15	78	15.5	47	18.7	24	38	4.5	8	15.75	30	10	5.0	8	10	60	6.0	2.0	M5
20	92	21.0	63	22.6	30	53	5.5	10	21.00	40	12	7.0	11	10	60	7.0	2.0	M6
25	98	23.0	70	27.0	36	57	6.6	11	23.50	45	16	8.5	13	10	60	10.0	2.5	M8
35	135	32.0	100	37.0	48	82	9.0	15	34.00	62	20	10.5	20	12	80	11.5	3.5	M10
45	165	45.0	120	46.0	60	100	11.0	18	37.50	80	24	13.5	22	16	105	14.5	4.0	M12

Dimensions (mm)

**Both underside mounting hole FDC version guides (Ref. ordering instructions)**

Size	Length										L11							
	Ls	B	BS	h3	h9	as	d2	D2	e	fs	h8	h10	h11	min.	L12	t2	t3	N1
12	64	12.0	37	14.7	19	30	3.4	6	12.50	29	8	4.0	6	10	40	5.5	1.4	M4
15	78	15.5	47	18.7	24	38	4.5	8	15.75	34	10	5.0	8	10	60	6.0	2.0	M5
20	92	21.0	63	22.6	30	53	5.5	10	21.00	40	12	7.0	11	10	60	7.0	2.0	M6
25	98	23.0	70	27.0	36	57	6.6	11	23.50	45	16	8.5	13	10	60	10.0	2.5	M8
35	135	32.0	100	37.0	48	82	9.0	15	34.00	62	20	10.5	20	12	80	11.5	3.5	M10
45	165	45.0	120	46.0	60	100	11.0	18	37.50	90	24	13.5	22	16	105	14.5	4.0	M12

Dimensions (mm)

**Roll**

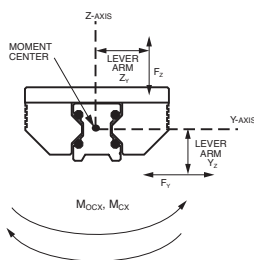

**Pitch**

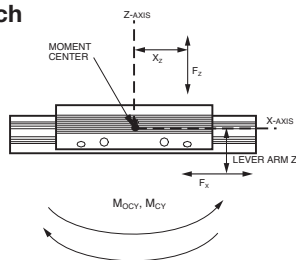

**Yaw**

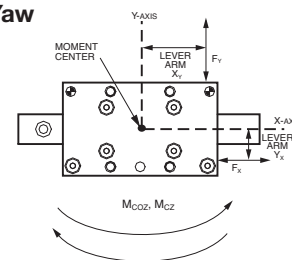

**Load & moment rating capacities (for cassettes on double sided rail)**

Dynamic Load Rating C (N)	Static Load Rating Co (N)	Static Moment Rating Capacities:			Dynamic Moment Rating Capacities:			Cassette Weight (kg)	Rail Weight (kg) per "M"	Cassette Series
		Roll Mocx (Nm)	Pitch Mocy (Nm)	Yaw Mocz (Nm)	Roll Mcx (Nm)	Pitch Mcy (Nm)	Yaw Mcz (Nm)			
<b>High Performance Series</b>										
2800	3000	27	43	43	25	40	40	0.1	0.4	FDC12HP-...
4200	3400	37	58	58	45	72	72	0.3	0.8	FDC15HP-...
5400	5400	76	111	111	76	111	111	0.4	0.9	FDC20HP-...
9000	10100	158	222	222	142	198	198	0.6	1.8	FDC25HP-...
12500	18000	423	559	559	294	388	388	1.5	3.2	FDC35HP-...
21200	25900	827	983	983	678	806	806	2.9	5.5	FDC45HP-...



For inventory, lead times, and kit lookup, visit [www.pdnplu.com](http://www.pdnplu.com)

G111

Parker Hannifin Corporation  
 Pneumatic Division  
 Wadsworth, Ohio  
[www.parker.com/pneumatics](http://www.parker.com/pneumatics)



Rodless Pneumatic Cylinders

OSP-P Series

P1X Series

GDL Series

**GDL Aluminum Roller Guides**

**High performance cassettes with lock device**



The locking cassette with star grip handle can be stopped at any desired location on the rail. The clamping device does not exert forces on the rail guideways.

The clamping device is used in fixtures which are movable manually, clamping and stop ledgers, feeding of tools and work pieces. Also available with L-ratchet handle.

**Special cassette types**

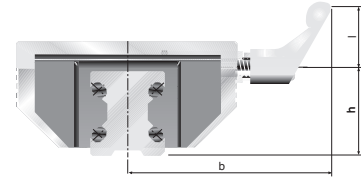
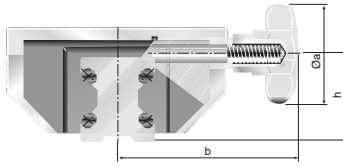

**Star grip handle dimensions**

Size	Øa	b	h	Clamp Force	Part Numbers Star Grip Knob
12	N/A				
15	25	41	19.0	200	<b>FDC15HP-00020000</b>
20	25	49	23.0	250	<b>FDC20HP-00020000</b>
25	32	56	28.0	250	<b>FDC25HP-00020000</b>
35	50	83	38.5	350	<b>FDC35HP-00020000</b>
45	63	101	48.0	750	<b>FDC45HP-00020000</b>

**L-ratchet handle dimensions**

Size	l	b	h	Clamp Force	Part Numbers L-Ratchet Handle
12	N/A				
15	45	59.5	19.0	200	<b>FDC15HP-00010000</b>
20	45	67.5	23.0	250	<b>FDC20HP-00010000</b>
25	45	71	28.0	250	<b>FDC25HP-00010000</b>
35	63	96	38.5	350	<b>FDC35HP-00010000</b>
45	78	116	48.0	750	<b>FDC45HP-00010000</b>

Dimensions (mm), Force (N) with normal manual tightening.

**End of stroke stop screws**

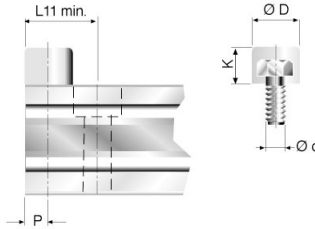
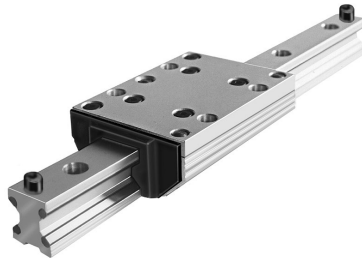

The stop screws are screwed into threads (option) on the guide rails. The end of stroke stopping energy is reduced by a rubber cap. With guide rails where the L11 is less than the standard minimum, we offset the mounting hole by half of its diameter.

**Note:** Customer must drill and tap the holes for the stop screws.

Size	Ød	ØD	K	L11 min.	P	Part Number
12	M5	12	8	15.0	6.0	<b>63504A</b>
15	M5	12	8	16.0	6.0	<b>63504A</b>
20	M5	12	8	17.0	6.0	<b>63504A</b>
25	M6	15	10	20.5	7.5	<b>63505A</b>
35	M8	19	13	26.5	9.5	<b>63506A</b>
45	M10	24	16	33.0	12.0	<b>63507A</b>

Dimensions (mm)

**GDL Accessories**

**Rail mounting screw covers**

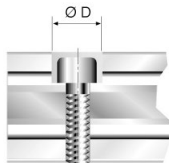
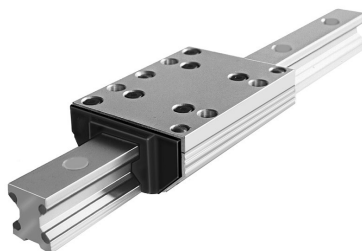

**Material:** Wear resistant plastic, resistant to oil and aging.

**Mounting:** Put a plastic plate on top and pound in uniformly. Remove residual burrs with a soft brush or fingernail.

**Note:** Use respective part numbers for ordering separately or include in rail part number.

Size	Cylindrical Screw DIN912	Ø D	Part Number
12	M3	6	<b>87752A</b>
15	M4	8	<b>42074FIL</b>
20	M5	10	<b>87754A</b>
25	M6	11	<b>87755A</b>
35	M8	15	<b>6973</b>
45	M10	18	<b>87757A</b>

Dimensions (mm)

**G**  
 Rodless Pneumatic  
 Cylinders  
 OSP-P  
 Series  
 P1X  
 Series  
 GDL  
 Series



For inventory, lead times, and kit lookup, visit [www.pdnplu.com](http://www.pdnplu.com)

**GDL Aluminum roller guides with wipers**

**Version with wipers**

Integrated into an additional cover, a felt wiper is saturated with oil. Although dependent on the degree of contaminants, these wipers last for some 6000km, after which the felt wipers can either be washed or replaced.

For optimal cassette rolling performance, all holes in the guide rails should be filled with the plastic rail mounting screw covers.

**Part numbers for replacement wiper kits**

FDC Series and Size	Respective Part Number
12	<b>FDC12-WIPER-KIT</b>
15	<b>FDC15-WIPER-KIT</b>
20	<b>FDC20-WIPER-KIT</b>
25	<b>FDC25-WIPER-KIT</b>
35	<b>FDC35-WIPER-KIT</b>
45	<b>FDC45-WIPER-KIT</b>

Cassette with full profile snap-on wipers



Full profile snap-on wiper

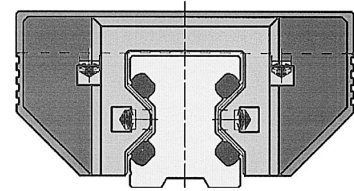

**GDL's keyed butt-jointed rail option**

GUIDELINE rails can be precisely fastened together using a factory offered keyed butt-joint option for continuous rail lengths, as shown in Figures 1 & 2.

Two rail sections are clamped together with mating round bar stock pieces that seat tangent to both rail section guideways on each side of the rail. While the rail sections are clamped together, a keyway slot is machined in the top and bottom sides of the rail, across the butt-joint. Screw holes are then drilled through the rail inside the keyway slot, so the opposing keyways can be drawn together tightly with screws. The round bar stock clamp is then removed, providing a rigid and well aligned keyed butt-joint.

The keyed butt-joint option provides optimum alignment of all guideways from one rail section to the next. This allows for optimum "smooth" guidance of the cassette bearings, while crossing rail butt-joints.

The keyed butt-jointed rail option is currently available in the FDR version 25, 35, & 45 mm rail sizes. For a keyed butt-joint on rail sizes 25, 35 or 45 mm, specify P/N:# GDL-BJK

Consult factory for other size possibilities.



**Figure 1**

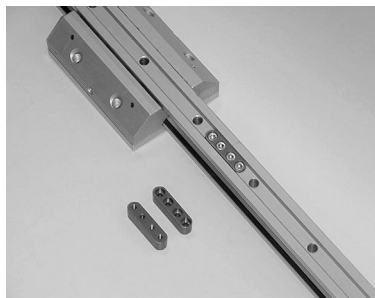

**Figure 2**

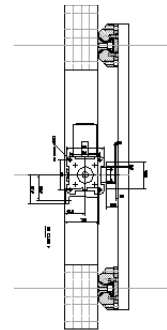

**Figure 3**

GDL linear guides couple well with various structural aluminum extrusions and Parker OSP-P actuators. Mounting can be easily accomplished using standard fasteners and mounting brackets. See Figure 3 above.

**1. Features of the Guide System**

Aluminum roller guides consist of a double sided rail and a roller cassette or two single sided rails and two roller shoes. Aluminum roller guide rails and cassettes are made of aluminum alloy. The rollers are very smooth running on precision polished guideways made of high alloy spring steel. The special cross pattern orientation of the running rollers provides high load and moment capacity in all directions.

Their special features are: light weight, small dimensions, and high speed of displacement. Aluminum roller guides are economical and universal handling components, which are mostly or all corrosion-resistant and available at a favorable price.

**2. Size of the Guide System**

To select the right guide size, first the moments and forces acting on the bearing have to be determined.

Recommended safety factors (with ISO screws quality 8.8):

- Thrust load      S > 1.3
- Tensile load     S > 4.0
- Moment load    S > 6.0

**3. Material**

The basic body of GDL aluminum roller guides is made of aluminum alloy. The guideways consist of hardened, high alloy spring steel or of stainless steel. By using basic bodies of aluminum, the moved masses are reduced which allows light-weight construction requiring lower moving forces and reduced energy consumption. Still the integrated GDL system sustains high load and moment ratings.

**4. Operating Temperature**

GDL linear guides can be operated within a temperature range from -10° C up to 80°C. For other temperatures, please consult factory.

**5. Screwed Connections**

GDL linear guides are fixed to the mating structure by the mounting holes in the rails and the cassettes. ISO screw quality 8.8 should be used with DIN 433 washers.

To secure the screwed connections, we recommend that suitable locking means be utilized as necessary.

Mounting screw torque specifications:

Screw	Quality 8.8 [Nm]
M3	1.1
M4	2.5
M5	5.0
M6	8.5
M8	21.0
M10	41.0
M12	71.0

**6. Wipers**

The guideways of aluminum roller guides are equipped with wipers to protect against coarse environmental contamination.

**7. Slide Resistance / Adjustment**

Follow the steps on how to adjust GDL cassettes to the rail.

The new GDL catalog has many changes due to an expanded product line. The change to feature descriptive part numbering was done to accommodate all current and future offerings of the GDL product. The goal is to have standard features and options available, for a perfect fit into your application.

Included in the chart below are hex sizes, drag resistance and torque ratings for adjusting the cassette.

**GDL Chart**

	FDC 12	FDC 15	FDC 20	FDC 25	FDC 35	FDC 45
Top plate hex (mm)	2	3	4	4	5	6
Top plate torque (in lbs)	n/a	22.1	44.3	44.3	75.2	186
Adjustment hex (mm)	1	3	3	4	4	4
Drag resistance (oz) HP, HC, GF, VA	1.8-7.9	3.6-10.8	5.4-16.2	7.2-21.6	10.8-32.4	12.6-37.7
Drag resistance (oz) SP & SC	.7-1.8	1.8-3.6	3.6-7.2	5.4-10.8	7.2-14.4	9-18
Drag resistance (oz) HD	n/a	n/a	n/a	9-18	14.4-25	18-28.7

**7.1 GDL Adjustment Procedure**

**Do not measure sliding resistance with wipers on.**

- 1) Lay the rail out on the flat surface with the **datum** line facing away from you. Anchor the rail to keep it from shifting when sliding resistance is applied to the cassette.

*The datum line is a reference groove on one side of the rail.*

- 2) Set the roller cassette on the rail with the adjustment screw facing towards you, while the datum line on the rail is away from you. Do not install the wipers on the cassette yet.

*Do not install the wipers yet.*

- 3) Make sure the four bolts on the adjustable side of the cassette are slightly loose and the bolts on the fixed side are tight before adjusting the drag screw.

*One side of the cassette is fixed and the other side is floating.*

- 4) The drag hex screw is located on one side of the cassette. Adjust the screw in for more drag and out for less. Do not try to adjust cassette with top plates bolts tight.

*See the chart for drag adjustment hex screw size.*

- 5) Adjust the drag on the cassette by sliding as it slides down the rail. Feel for an even amount of resistance as you turn the hex screw in and out.

- 6) Tighten down the top plate bolts to the proper torque specification. The tightening of the top plate bolts will add some resistance. If necessary, the adjustment procedure can be repeated for better sliding resistance for your application.

*See the chart for top plate hex size and torque rating.*

- 7) If the adjustment is done without a scale, it should move evenly. Some examples of improper adjustment are: If the



cassette “hops”, it is too tight. If it is too loose, the top plate of the cassette will have play. Try to be in the middle.

- 8) To check your settings use a pull or push style scale. Slide the cassette down the entire rail at an even speed, measuring the drag resistance. Your highest drag rating should be referenced when looking at the chart.

*See the chart for drag resistance ratings for the size and type of cassette.*

- 9) Install the clip on wipers. The wipers will add between 1-3 ounces of resistance. The wipers do not add any additional roller preload to the rail.

*The clip on wipers can be installed at this time.*

### 7.2 Double Sided Rail and Cassette

Aluminum roller guides are adjusted in such a way that the required stiffness under load is obtained. If self adjustment is preferred, we recommend that you measure the slide resistance as shown below. Before doing so, the mating structure should be checked for dimensional accuracy and flatness.

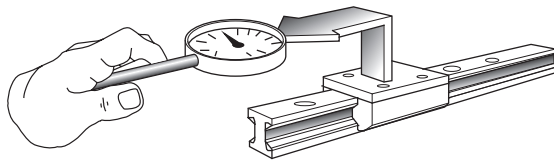

The cassettes which are mounted on the rails are adjusted clearance-free, without play. This adjusting method is required at the point on the rail where the cassette travels with the least slide resistance. Adjustment is completed in the non-loaded condition. The tolerances below refer to this condition.

#### Slide resistance adjustment tolerance [N]

Series	FDC_HP, FDC_HC, FDC_AM, FDC_GF, FDC_VA						FDC_SP, FDC_SC						FDC_HD		
	12	15	20	25	35	45	12	15	20	25	35	45	25	35	45
Adjust. value	0.5	1.0	1.5	2.0	3.0	3.5	0.2	0.5	1.0	1.5	2.0	2.5	2.5	4.0	5.0
Max. value	2.0	3.0	4.5	6.0	9.0	10.5	0.5	1.0	2.0	3.0	4.0	5.0	5.0	7.0	8.0

All values are without wipers

Tolerances in the guide system may cause slight variations in the slide resistance, when the adjusted cassette is moved along the guide rail.

### 7.3 Double Sided Rail and Roller Cassette

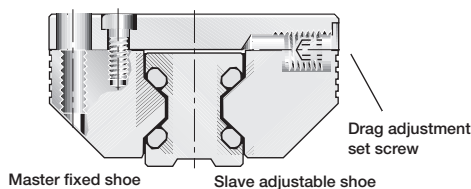

To change the clearance setting, first the slave adjustable shoe screws on the cassette top plate are slightly loosened.

Afterwards, the drag adjustment set screw is turned to increase or decrease slide resistance of the cassette. Turning the drag adjustment set screw effects a displacement of the roller shoe in relation to the cassette top plate.

After re-tightening of the cassette top plate, the slide resistance can be checked. This procedure can be repeated until the desired slide resistance is achieved.

### 7.4 Rails and Rollershoes

When installing, it is important to distinguish between the master fixed side and the slave adjustable side rollershoe and rail. The rail on the master fixed side is aligned to the mating structure and fastened securely by all screws.

The rail on the slave adjustable side should be lightly tightened and movable with light force during initial alignment of parallel rails. Gauge blocks should be used between the parallel rails, by locating off the aligned and mounted master rail, in order to align the slave rail parallel to the master rail. Slave rail mounting bolts should be tightened as the slave rail is aligned at each bolt position. See paragraph 11.3 for further instructions on mounting parallel single sided rails.

### 7.5 Centering Groove on the Master Fixed Shoe and Custom Top Plate

Each pair of rollershoes are provided with centering grooves for optimum alignment to their mating top plate during mounting. One rollershoe should be designated as the master fixed rollershoe, even though both are designed with a centering groove on their top surface. The other shoe will serve as the slave adjustable side rollershoe. The mating customized top plate should be machined with a centering shoulder according to the following data.

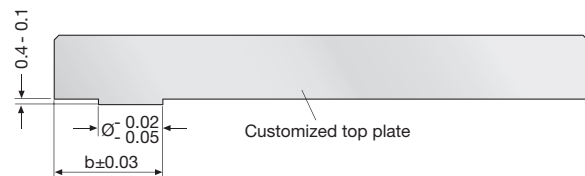

Size	a	b
12	4,5	9,6
15	5,0	12,6
20	7,5	16,1
25	10,5	17,6
35	12,5	26,1

### 7.6 Adjusting Cassette Built with Rollershoes and Custom Top Plate

The centering shoulder on the top plate should be assembled with its respective fixed rollershoe centering groove and securely torqued to recommended specification. See cassette screw torque specifications under step 5, on previous page.

Assemble the adjustable rollershoe to the top plate also, parallel to the fixed rollershoe on the same side of the top plate. Its fasteners should be lightly tightened so that the adjustable rollershoe can be moved with light finger pressure.

**G**  
 Rodless Pneumatic Cylinders  
 OSP-P Series  
 P1X Series  
 GDL Series



As assembled cassette can then be slid onto parallel rails, while keeping the fixed rollershoe on the master fixed rail side. The incorporated drag adjustment set screw can then be turned clockwise to remove cassette play, or counter clockwise to reduce slide resistance while maintaining zero play.

Once the desired slide resistance is achieved with no cassette play, the adjustable rollershoe fasteners can also be torqued to specification.

### 8. Running accuracy

The running accuracy is measured from the top plate surface of the cassette, to the ideal straight line of travel. Running accuracy of the cassette to the rail is +/- .03mm (.0012") per meter, granted no greater than (.0024") straightness deviation per meter is maintained when mounting the rail.

### 9. Contact and support surfaces

The contact and support surfaces have a substantial influence on functioning and precision of linear guides. Depending on the functional requirements of the system, the mating structure has to be machined with the corresponding degree of precision.

Machining errors on the mating structure will otherwise add to the running error of the guide system. In order to assure troublefree functioning, we recommend that a max. straightness deviation of  $\leq 0.1 \text{ mm}$  (.0039") per running meter be maintained when mounting the rail.

### 10. Design hints

#### 10.1 Parallel double sided rails and cassettes

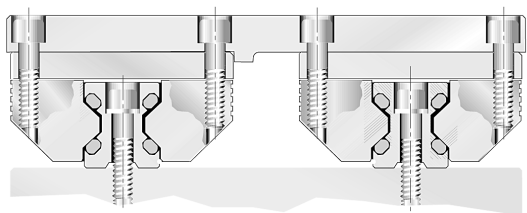

The master fixed rail should always be established straight and true first, within the maximum straightness deviation specified in paragraph 9. With parallel rail arrangements, both rails should be mounted on the same mounting surface elevation and treated with equal surface preparation and tolerancing practices. Precise alignment in terms of spacing, parallelism and height is very important.

When coupled parallel to a driving actuator system, the adjustable side of the cassette should be placed on the side closest to the driving actuator. This will minimize driving actuator torque transferred to the adjustable side of the cassette.

### 11. Guide mounting instructions

The useable load capacity is influenced by the connection between the guide elements and the mating structure. For this reason, a flat, straight and solid secure mounting surface should be provided. Adequate support of qualified loads and moments can then be achieved, along with desired running accuracy.

#### 11.1 Mounting Double Sided Rails and Cassette

Depending on the load situation, certain double sided rails

## Rodless Pneumatic Cylinders GDL Series

should either be screwed or screwed and dowelled, and respectively put into grooves or against a shoulder.

The rails can be secured best against shoulders and are screwed or screwed and dowelled to the mating structure.

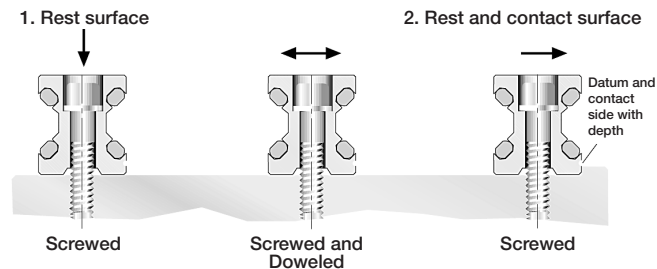

After final adjustment of rail straightness and parallelism, the rail mounting screws are tightened starting in the middle of the rail length. Rail mounting bolts should be torqued to specification by alternating between each bolt. The installer should start with the bolt in the center of the rail length and proceed by alternating between each bolt left of center and each bolt right of center, while working towards both ends of the rail.

Afterwards, the cassette should be moved back and forth along the total stroke distance of the rail. If the cassette travels smoothly, the mounting process can proceed or be completed.

#### 11.2 Mounting Parallel Double Sided Rails and Cassettes

With parallel double sided rail arrangements, we recommend that the master fixed rail side and slave adjustment rail sides of the guide system be identified. This allows optimum tolerances in parallelism to be achieved best by adjusting the slave adjustable rail, parallel to the master rail. The master fixed rail side should be mounted first to achieve the initial line of straight travel.

The example below displays a convenient method for adjusting the slave adjustable rail parallel to the fixed master rail. Once the cassette travel is smooth, without play, one can proceed with rail mounting.

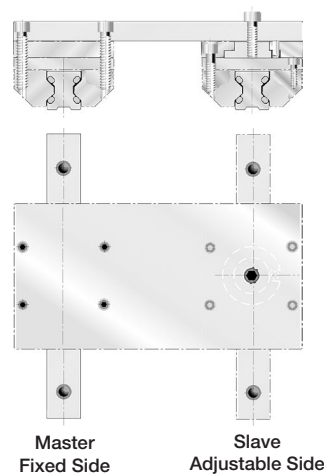

Note that the top plate spanning across the cassettes on opposite rails is completely bolted down to the cassette on the master fixed side only. The top plate end over the slave adjustable side is only bolted in one location, in the center of the slave adjustment side cassette. With one bolt holding the

## Technical Data

top plate to the slave adjustment side cassette, this cassette can pivot while the slave adjustable rail self-aligns parallel to the fixed master rail side. The floating top plate setup is stroked along the entire rail length, to establish the parallelism between the two rails.

Calibrated gauge blocks can also be used to establish equal integrity in rail parallelism. The installer should seat and temporarily clamp short pieces of precision ground round stock, tangent to the two guideways on the inside of each rail.

Rail Size	Precision Round Stock Sizes Ø mm
12	11
15	11
20	14
25	16
35	27
45	35

The calibrated gauge blocks can then be used, to locate off the precision round stock on the master fixed rail, in order to set the slave adjustable rail parallel. The gauge blocks are then locating the same way that the floating top plate is, by referencing both the master and slave rail guideway surfaces to establish parallelism.

Once the slave adjustable rail has been self-aligned, its bolts should also be torqued to specification in the order mentioned in paragraph 11.1. The top spanning across both cassettes on opposite rails, can then be securely fastened using all cassette mounting bolt holes.

## 12. Keyed Butt-jointing of Rail Sections

### 12.1 Rail Hole Spacing

Butt-jointed rails over L = 4000 mm are sectioned together according to the GDL standard. See "GDL's Keyed Butt-Jointed Rail Option" on page G114. Butt-jointed rails sections are cut so that the standard rail mounting hole spacing is maintained across all butt-joints.

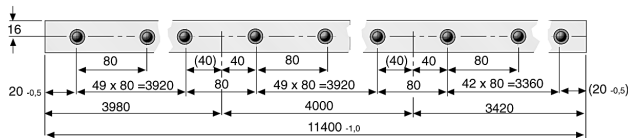

Keyed butt-jointed rails are usually shipped completely assembled, but sometimes must be shipped partially assembled, due to shipping length limitations and shipping care. Partially assembled butt-jointed rails are supplied with a butt-jointing clamping fixture and the keyways and screws for fastening rail section together.

### 12.2 Mounting of butt-jointed rails

Clean mounting surfaces, then place rail sections loose on the guide path, one behind the other. Lay the rails in their correct sequence of the system design (i.e.: 1, 2, 3, 4...etc.). The orientation of the depth groove on the lower surface of the rail should always be on the same side for all rail sections being butt-jointed.

## Rodless Pneumatic Cylinders GDL Series

Any non-assembled rail sections should be aligned with the factory supplied butt-joint clamping fixture as displayed below.



See explanation of "GDL's Keyed Butt-Jointed Rail Option" on page G114.

Once all rail sections are assembled, the complete guide path can be aligned and fastened. Alignment and fastening should be conducted according to the applicable guide arrangement and steps previously described in this technical information section.



Rodless Pneumatic  
Cylinders

OSP-P  
Series

P1X  
Series

GDL  
Series



**Units Conversion Tables**

**Force Conversions:**

Multiply	By Conversion Factor Result	
pound-force	4.448	Newton
Newton	0.225	pound-force
kilogram-force	9.807	Newton
Newton	0.102	kilogram-force

**Acceleration Conversions:**

Multiply	By Conversion Factor Result	
feet/section <sup>2</sup>	0.305	meter/second <sup>2</sup>
meter/second <sup>2</sup>	3.281	feet/second <sup>2</sup>
inch/second <sup>2</sup>	0.025	meter/second <sup>2</sup>
meter/second <sup>2</sup>	39.370	inch/second <sup>2</sup>

**Mass Conversions:**

Multiply	By Conversion Factor Result	
ounce	28.349	gram
gram	0.035	ounce
kilogram	35.279	ounce
gram	0.001	kilogram
pound	0.453	kilogram
kilogram	2.205	pound

**Bending Moment or Torque Conversions:**

Multiply	By Conversion Factor Result	
pound-foot	1.356	Newton-meter
Newton-meter	0.737	pound-foot
Newton-meter	0.102	kilogram-meter
Kilogram-meter	9.807	Newton-meter

**Velocity conversions:**

Multiply	By Conversion Factor Result	
mile/hour	1.609	kilometer/hour
kilometer/hour	0.621	mile/hour
feet/second	0.305	meter/second
meter/second	3.281	feet/second
inch/minute	0.025	meter/minute
meter/minute	39.370	inch/minute

**Length conversions:**

Multiply	By Conversion Factor Result	
inch	25.4	millimeter
millimeter	0.039	inch
inch	0.025	meter
meter	39.370	inch
foot	0.305	meter
meter	3.281	foot

**Rodless Pneumatic Cylinders**  
 OSP-P Series  
 P1X Series  
 GDL Series



For inventory, lead times, and kit lookup, visit [www.pdnplu.com](http://www.pdnplu.com)



**GDL Application Sheet**

Distributor: \_\_\_\_\_ End-User: \_\_\_\_\_

Salesperson: \_\_\_\_\_

Phone: \_\_\_\_\_ Fax: \_\_\_\_\_ e-mail: \_\_\_\_\_

Other Information: \_\_\_\_\_

**Roll**

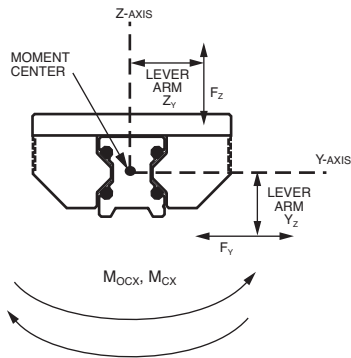

Roll load \_\_\_\_\_  
 X - Distance \_\_\_\_\_  
 Y - Distance \_\_\_\_\_  
 Z - Distance \_\_\_\_\_

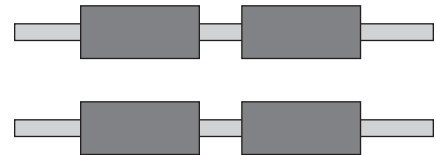

Length of rails \_\_\_\_\_  
 Distance between rails \_\_\_\_\_  
 Distance between cassettes on each rail \_\_\_\_\_

**Pitch**

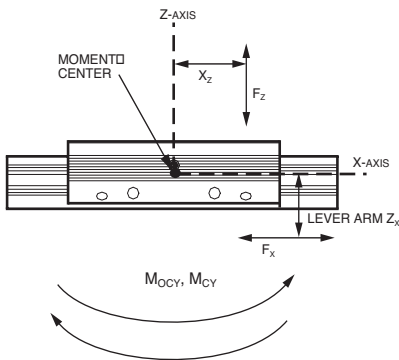

Pitch load \_\_\_\_\_  
 X - Distance \_\_\_\_\_  
 Y - Distance \_\_\_\_\_  
 Z - Distance \_\_\_\_\_

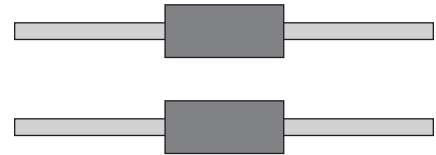

**Technical Data:**  
 Stroke \_\_\_\_\_  
 Horizontal \_\_\_\_\_  
 Vertical \_\_\_\_\_

**Yaw**

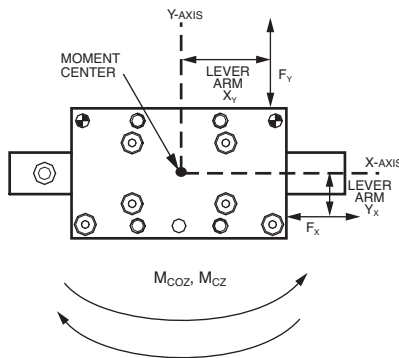

Yaw load \_\_\_\_\_  
 X - Distance \_\_\_\_\_  
 Y - Distance \_\_\_\_\_  
 Z - Distance \_\_\_\_\_

Velocity / Speed \_\_\_\_\_  
 Acceleration \_\_\_\_\_  
 Load / Mass \_\_\_\_\_  
 Load Distances \_\_\_\_\_  
 Lifetime Desired \_\_\_\_\_

**Environment:**  
 (Dirt, Humidity...)

**G**

Rodless Pneumatic Cylinders

OSP-P Series

P1X Series

GDL Series



For inventory, lead times, and kit lookup, visit [www.pdnplu.com](http://www.pdnplu.com)

G119

**Parker Hannifin Corporation**  
 Pneumatic Division  
 Wadsworth, Ohio  
[www.parker.com/pneumatics](http://www.parker.com/pneumatics)



Rodless Pneumatic  
Cylinders

OSP-P  
Series

P1X  
Series

GDL  
Series



For inventory, lead times, and kit  
lookup, visit [www.pdnplu.com](http://www.pdnplu.com)

G120

**Parker Hannifin Corporation**  
Pneumatic Division  
Wadsworth, Ohio  
[www.parker.com/pneumatics](http://www.parker.com/pneumatics)

**Rotary Actuators**  
**Vane / Rack & Pinion Series**

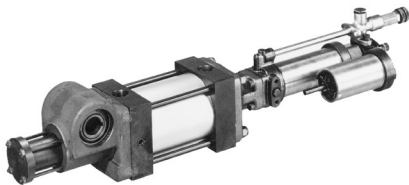
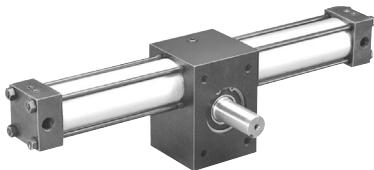
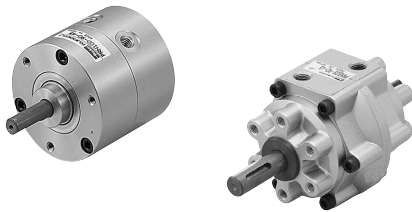
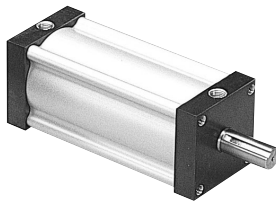

<b>Overview</b>	H2
-----------------	----

<b>PV Series – Vane</b>	
Features	H3-H4
Ordering Information	H4
Specifications	H5
Technical Data	H6
Dimensional Data	H7
Options	H7-H10

<b>PRNA / PRN Series – Vane</b>	
Features	H11-H12
Ordering Information	H12
Specifications	H13-H14
Dimensional Data	H15-H17
Options	H18-H22

<b>PTR Series – Rack &amp; Pinion</b>	
Features	H23-H24
Ordering Information	H24
Specifications	H25-H26
Technical Data	H27
Dimensional Data	H28
Options	H29-H37

<b>B671 / F672 Series – Rack &amp; Pinion</b>	
Features	H38-H39
Ordering Information	H40
Specifications	H39
Dimensional Data	H41

<b>HP Series – Rack &amp; Pinion</b>	
Features	H42-H43
Ordering Information	H43
Specifications	H44
Dimensional Data	H45
Options	H45-H46

## Overview

## Selection Guide

Basic performance features of the rotator product line are shown below. See product sections for greater detail and ordering information.

Type	Vane		Rack & Pinion			
	Series	PV	PRN(A)	PTR	B671	HP
Standard Rotations		95°/100° <sup>1</sup> 275°/280° <sup>2</sup>	90°/100° <sup>1</sup> 180° <sup>2</sup> 270°/280° <sup>2</sup>	90° 180° 270° 360°	90° 180°	90° 180°
Maximum Torque at 100 PSI (lb-in)		1800	2540	2000	2500	10,000
Maximum Air Pressure Rating (PSI)		150	100/140	250	140	100
Shaft Bearing Type		Ball or Composite Bushing	Composite	Radial Ball Bushing	Bronze Bushing	Bronze Bushing
Non-Lube Service		●	●	●	●	●
Metric (M) or Imperial (I)		I	M	M,I	I	I
Switch Options	Hall Effect	●	●	●		
	Reed	●	●	●	C	
	Proximity Sensor			●		●
Shaft Options	Double End	●	●	●		
	Female			●	●	●
	Preload Keyway			●		
	Special	C		C	C	C
Rotation Options	Stroke Adjust	●	●	●		●
	Cushions			●	●	●
	Bumpers	●	●	●		
	Shock Absorbers		●	●		
Port Relocation		●	●	●	C	●
3-Position		C		●		
Air / Oil				●	● <sup>3</sup>	
Zero Backlash		●	●	●		
Fluorocarbon Seals		●	●	●		●
Flange Mount		●	●	●		
Washdown		●	C	C		

● = Available from catalog

C = Consult Factory

<sup>1</sup> Double vane

<sup>2</sup> Single vane

<sup>3</sup> Hydro-check option

**PV Series**

**HEADS**

Solid stock heads are precision machined from aluminum, then hard-coat anodized and permanently sealed to ensure long seal life and low breakaway pressure. Solid stock heads eliminate cavities where contaminants may collect and also allow rear porting.

**BODY**

The precision body extrusion is hard-coat anodized and permanently sealed, resulting in a smooth, slick seal surface. This guarantees minimum breakaway and maximum seal life. The unitized body incorporates the stator(s) for superior rigidity.

**SHOULDER SEAL**

A nitrile energized, glass-filled PTFE seal is utilized. It reduces bypass flow and friction, providing superior performance and long life.

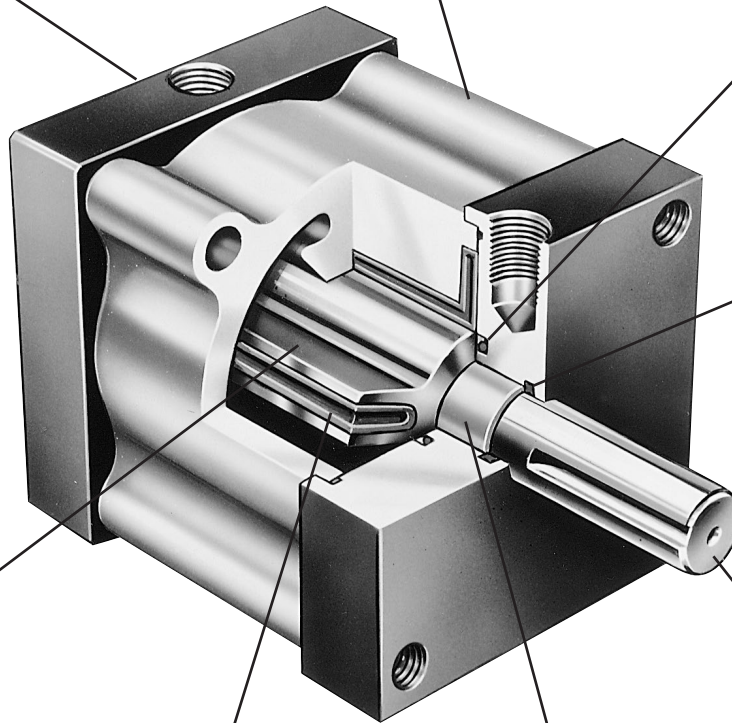

**VANE**

A hard-coat anodized, precision aluminum extrusion is permanently affixed to shaft. The lightweight vane reduces inertia allowing very fast rotational speeds.

**VANE SEAL**

A special self-lubricated, abrasion resistant nitrile compound is molded into a one-piece vane seal, providing low breakaway pressure and long life, even with no lubrication.

**SHAFT SEAL**

The high quality, self-lubricated, abrasion resistant nitrile seal is a multiple lobe construction for leak-free operation and greater reliability. (Cleanroom option available on sizes 22, 42, 44 and 46.)

**SHAFT**

Stainless steel provides high strength and corrosion resistance for demanding applications.

**SHAFT BEARING**

Thermoplastic journal bearing provides washdown capability and low cost. Optional radial ball bushing offers greater precision.

PV Series

PRN(A) Series

PTR Series

B671/F672 Series

HP Series

Rotary Actuators  
Products

**H**

Features

- Single or double vane rotary actuator
- 8 model sizes
- Output torque @ 100 PSIG: 8 to 1800 lb-in
- Standard rotations:  
 Single vane units: 280° ± 1°  
 (except size 10 & 11: 275° ± 2.5°)  
 Double vane units: 100° ± 1°  
 (except size 10 & 11: 95° ± 2.5°)  
 Available with stroke adjusters and internal stops to provide 90° and 180° rotation
- Stainless steel shaft
- Optional radial ball bushing shaft bearing

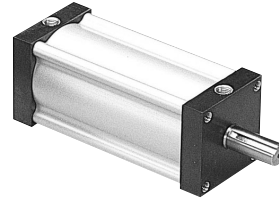

Operating information

Operating pressure:	150 PSIG (10.3 bar)
Temperature range:	30°F to 180°F (-1°C to 82°C)
Nitrile seals	30°F to 250°F (-1°C to 121°C)
Fluorocarbon seals*	30°F to 250°F (-1°C to 121°C)
* See fluorocarbon seal option for high temperature applications.	
Filtration requirements:	40 micron, dry filtered air

Ordering Information



Model			
10	22	33	42 <sup>5</sup>
11		36	44
			46

Vanes / Maximum Rotation	
Omit	Single Vane, 280° Rotation (275° on PV10, PV11)
D	Double Vane, 100° Rotation (95° on PV10, PV11)

Rotation Options (may order more than one)	
Omit	Standard Units (no stroke adjusters, bumpers or switches)
090A	Stroke Adjusters Adjustable from 60° to Maximum Unit Rotation (preadjusted to 90°)*
180A	Stroke Adjusters (single vane only) Adjustable from 60° to 190° (preadjusted to 180°)*
090B	Internal Bumpers, 90° Rotation <sup>4</sup>
180B	Internal Bumpers, 180° Rotation (single vane only)
090S	Magnets <sup>1</sup> Added, 90° Setting
180S	Magnets <sup>1</sup> Added, 180° Setting (single vane only)

\* Stroke adjusters cannot be ordered with bumpers

1. Switches can be used with stroke adjusters or bumpers (example: PV22D-090BS-BB2-B).
2. Not available with switches or stroke adjusters.
3. No tapped mounting holes in face opposite the flange.
4. 90° bumpers (090B) not available on PV10/11 sizes.
5. PV42 only available in double vane

**Note:**  
Order Hall effect sensors and reed switches separately from the Electronic Sensors section.

Special Options	
Omit	Standard
Two digit code assigned by factory when any "X" appears in the model number or when special options or features are required.	

Design Series	
B	Current Design Series

Options	
Omit	None
L	Radial Ball Bushings
V	Fluorocarbon Seals

Ports	
2	NPTF Top (Std) (10-32 on PV10 & PV11)
7	NPTF Rear <sup>2</sup> (10-32 on PV10 & PV11)

Shaft	
B	Single Male Keyed (Std)
C	Double End Male Keyed <sup>2</sup>

Mounting	
B	Base / Front (Std)
R	Rear Flange <sup>2,3</sup>
F	Front Flange
S	Base / Rear Face <sup>2</sup>

**Sensors**  
See section L for sensors.

PV Series  
PRN(A) Series  
PTR Series  
B671/F672 Series  
HP Series  
Rotary Actuators Products  
H



For inventory, lead times, and kit lookup, visit [www.pdnplu.com](http://www.pdnplu.com)

**Quick reference data**

Model Number	Maximum Rotation (Degrees)	Actual Output Torque (lb-in) at Specified Input Pressure (PSI)			Displacement (in <sup>3</sup> )	Maximum Breakaway Pressure (PSI)	Maximum Bypass Leakage @100 psi (CFM)	Unit Weight (lb)
		50	75	100				
10	275°	4	6	8	0.52	25	0.15	0.38
10D	95°	8	12	16	0.37	20	0.20	0.38
11	275°	8	12	16	1.04	20	0.15	0.50
11D	95°	17	25	33	0.74	15	0.20	0.50
22	280°	32	48	64	3.67	15	0.20	0.50
22D	100°	68	101	135	2.62	10	0.25	1.75
33	280°	75	112	150	8.70	15	0.20	3.44
33D	100°	155	235	315	6.20	10	0.25	3.56
36	280°	150	220	300	17.40	15	0.20	5.19
36D	100°	315	470	630	12.40	10	0.25	5.50
42D	100°	300	450	600	14.58	10	0.25	7.50
44	280°	285	425	570	35.61	15	0.20	8.81
44D	100°	600	900	1200	29.17	10	0.25	9.38
46	280°	425	640	850	53.41	15	0.20	10.50
46D	100°	900	1350	1800	43.75	10	0.25	10.75

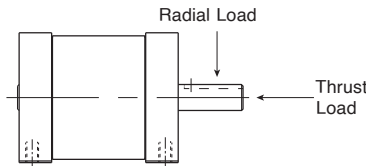

**Kinetic energy ratings and bearing load capacities**

Model Number	Composite Bushing Load Capacities (lb)*		Radial Ball Bushing Load Capacities (lb)*		Distance Between Centerline Bearings	Maximum Kinetic Energy Rating for Models Based on Configuration (in-lb)		
	Radial	Thrust	Radial	Thrust		Standard	Stroke Adjusters	Bumpers
10	15	7	50	15	0.88	0.03	0.12	0.05
11	15	7	50	15	1.50	0.06	0.12	0.09
22	50	25	Consult factory		2.38	0.25	0.50	0.38
33	100	50	Consult factory		3.50	0.75	1.50	1.13
36	100	50	Consult factory		6.50	1.00	1.50	1.50
42D	200	75	Consult factory		2.75	2.00	4.00	3.00
44	200	75	Consult factory		4.75	2.50	4.00	3.75
46	200	75	Consult factory		6.75	3.00	4.00	4.75

\* Bearing capacities only. Check Kinetic Energy ratings to determine if actuator will stop load.

**Seal kit ordering information**

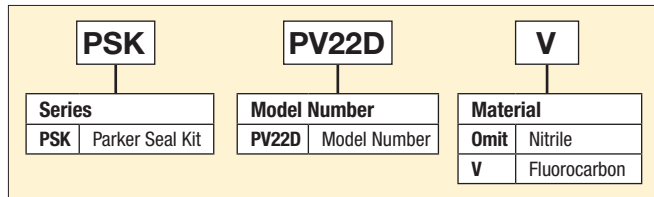

**Seal kit installation tool**

Model (S)	Items	Seal Guide Kit Number
PV10 & 11 (D)	21, 22	ATS-PV1
PV44 & 46 (D)	21, 22	ATS-PV4

**Kinetic Energy Basic Formula**

$$KE = 1/2 Jm\omega^2$$

$$\omega = 0.035 \times \frac{\text{Angle Traveled (Deg.)}}{\text{Rotation Time (Sec.)}}$$

where:

KE = Kinetic Energy (in-lb)

Jm = Rotational mass moment of inertia (in-lb-sec<sup>2</sup>)

(Dependent on physical size of object and weight)

$\omega$  = Peak Velocity (rad/sec) (Assuming twice average velocity)

W = Weight of load (lb)

g = Gravitational constant = 386.4 in/sec<sup>2</sup>

k = Radius of gyration (in)

**Moments of Inertia**

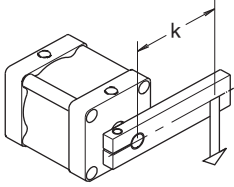
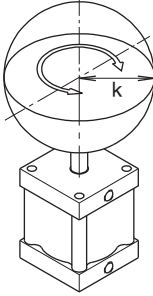
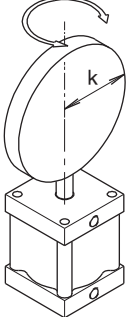
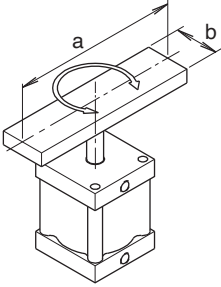
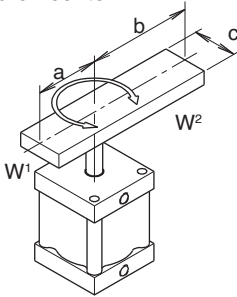
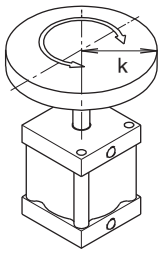
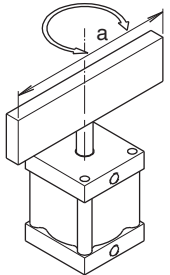
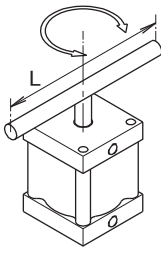
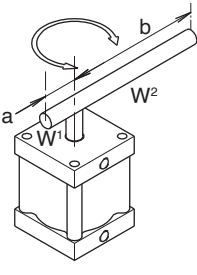
<p><b>POINT LOAD</b></p>  $Jm = \frac{W}{g} \times k^2$	<p><b>SOLID SPHERE -</b> Mounted on center</p>  $Jm = \frac{2}{5} \times \frac{W}{g} \times k^2$	<p><b>THIN DISK -</b> End mounted on center</p>  $Jm = \frac{W}{g} \times \frac{k^2}{4}$
<p><b>THIN RECTANGULAR PLATE -</b> Mounted on center</p>  $Jm = \frac{W}{g} \times \frac{a^2 + b^2}{12}$	<p><b>THIN RECTANGULAR PLATE -</b> Mounted off center</p>  $Jm = \frac{W^1}{g} \times \frac{4a^2 + c^2}{12} + \frac{W^2}{g} \times \frac{4b^2 + c^2}{12}$	<p><b>THIN DISK -</b> Mounted on center</p>  $Jm = \frac{W}{g} \times \frac{k^2}{2}$
<p><b>THIN RECTANGULAR PLATE -</b> End mounted on center</p>  $Jm = \frac{W}{g} \times \frac{a^2}{12}$	<p><b>SLENDER ROD -</b> Mounted on center</p>  $Jm = \frac{W}{g} \times \frac{L^2}{12}$	<p><b>SLENDER ROD -</b> Mounted off center</p>  $Jm = \frac{W^1}{g} \times \frac{a^2}{3} + \frac{W^2}{g} \times \frac{b^2}{3}$

PV Series  
 PRN(A) Series  
 PTR Series  
 B671/F672 Series  
 HP Series  
 Rotary Actuators Products  
**H**



**Standard Face/Base Mount (B) and Male Keyed Shaft (B)**

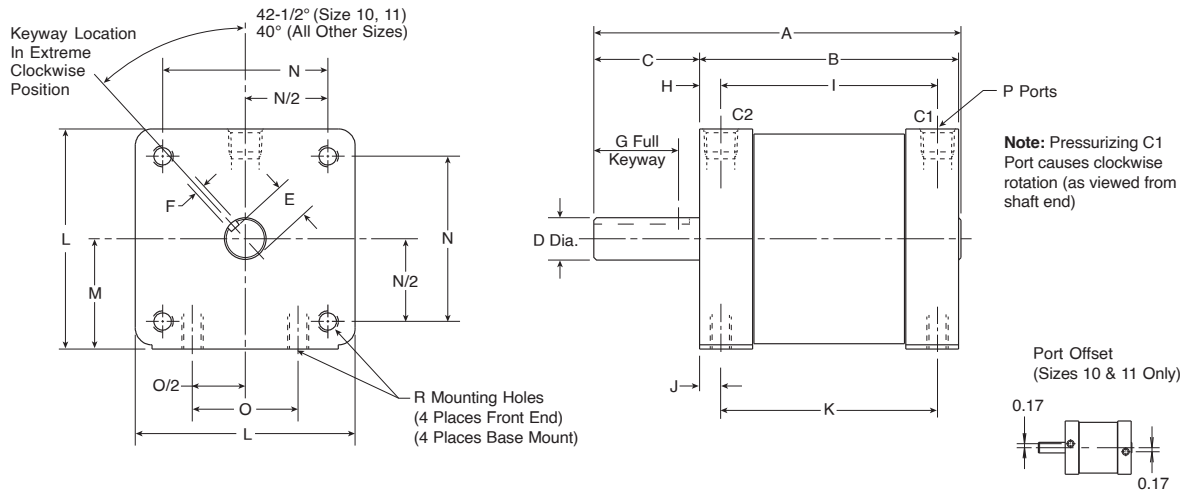

Model Number	A	B	C	D	E	F	G	H	I	J	K	L	M	N	O	P	R
10	2.280	1.38	0.88	0.312 0.311	0.258 0.253	0.095 0.094	0.63	0.19	1.00	0.19	1.000	1.62	0.810	1.220	0.750	10-32	8-32 x 0.25 DP
11	2.905	2.00	0.88	0.312 0.311	0.258 0.253	0.095 0.094	0.63	0.19	1.63	0.19	1.625	1.62	0.810	1.220	0.750	10-32	8-32 x 0.25 DP
22	4.340	3.06	1.25	0.500 0.499	0.423 0.418	0.126 0.125	0.94	0.25	2.56	0.25	2.560	2.50	1.250	2.000	1.250	1/8 NPTF	1/4-20NC x 0.38 DP
33	6.180	4.40	1.75	0.749 0.748	0.644 0.639	0.189 0.188	1.38	0.35	3.70	0.26	3.875	3.00	1.500	2.436	1.500	1/4 NPTF	5/16-18NC x 0.47 DP
36	9.180	7.40	1.75	0.749 0.748	0.644 0.639	0.189 0.188	1.38	0.35	6.70	0.26	6.875	3.00	1.500	2.436	1.500	1/4 NPTF	5/16-18NC x 0.47 DP
42D	6.280	4.00	2.25	0.999 0.998	0.859 0.854	0.251 0.250	2.00	0.50	3.00	0.50	3.000	4.50	2.250	3.500	2.375	1/4 NPTF	3/8-16NC x 0.75 DP
44	8.280	6.00	2.25	0.999 0.998	0.859 0.854	0.250 0.251	2.00	0.50	5.00	0.50	5.000	4.50	2.250	3.500	2.375	1/4 NPTF	3/8-16NC x 0.75 DP
46	10.280	8.00	2.25	0.999 0.998	0.859 0.854	0.250 0.251	2.00	0.50	7.00	0.50	7.000	4.50	2.250	3.500	2.375	1/4 NPTF	3/8-16NC x 0.75 DP

**Flange Mount (F, R)\***

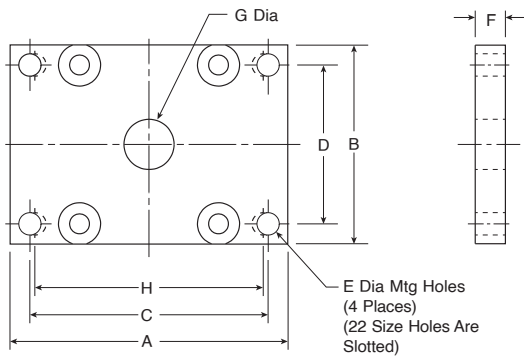

Model Number	A	B	C	D	E	F	G	H
10	2.50	1.62	2.000	1.250	0.203	0.19	0.41	N/A
11	2.50	1.62	2.000	1.250	0.203	0.19	0.41	N/A
22	3.50	2.50	3.000	2.000	0.281	0.25	0.66	2.875
33	4.50	3.00	3.750	2.000	0.344	0.38	0.84	N/A
36	4.50	3.00	3.750	2.000	0.344	0.38	0.84	N/A
42D	7.32	4.51	5.905	2.953	0.551	0.63	1.61	N/A
44	7.32	4.51	5.905	2.953	0.551	0.63	1.61	N/A
46	7.32	4.51	5.905	2.953	0.551	0.63	1.61	N/A

**Note:** The face opposite the flange mount does not contain tapped mounting holes. Consult factory if needed.



For inventory, lead times, and kit lookup, visit [www.pdnplu.com](http://www.pdnplu.com)

H7

**Parker Hannifin Corporation**  
 Pneumatic Division  
 Wadsworth, Ohio  
[www.parker.com/pneumatics](http://www.parker.com/pneumatics)

PV Series  
 PRN(A) Series  
 PTR Series  
 B671/F672 Series  
 HP Series  
 Rotary Actuators Products



Options

Double End Male Keyed Shaft (C)

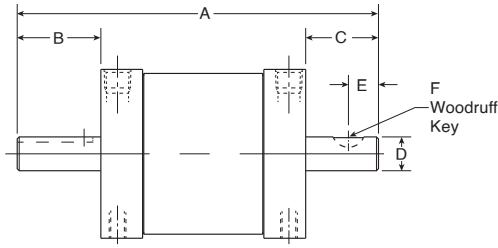

**Note:** Not available with switches or stroke adjustment. Consult factory for rear port option.

Model Number	A	B	C	D	E	F
10	2.75	0.88	0.50	0.312 0.311	0.28	#302.5
11	3.38	0.88	0.50	0.312 0.311	0.28	#302.5
22	5.06	1.25	0.75	0.500 0.499	0.44	#404
33	7.15	1.75	1.00	0.749 0.748	0.56	#606
36	10.15	1.75	1.00	0.749 0.748	0.56	#606
42D	7.53	2.25	1.28	0.999 0.998	0.72	#808
44	9.53	2.25	1.28	0.999 0.998	0.72	#808
46	11.53	2.25	1.28	0.999 0.998	0.72	#808

Adjustable Rotation Stop (090A, 180A)

An adjustable positive stop is available to provide end of rotation adjustability in a compact package. Total adjustment range is 60° to 190° on single vane actuators, and 60° to 100° on double vane actuators (95° on PV10/11 sizes). The rotation is factory preset to a nominal 90° or 180° (090A or 180A) for convenient installation.

**NOTE:**

1. Not available with double end shaft.
2. Not available with rear ports.

SINGLE VANE UNIT

DOUBLE VANE UNIT

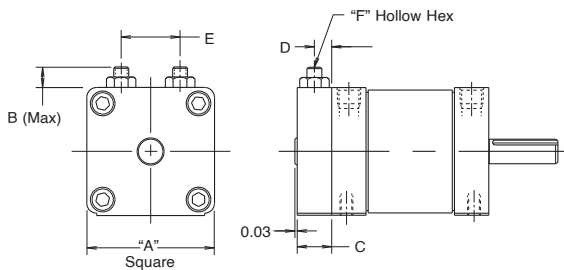
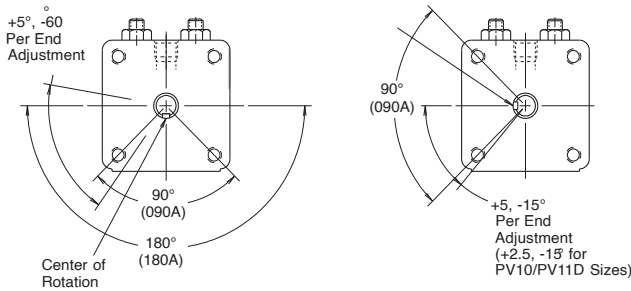

Model Number	A	B	C	D	E	F
10	1.62	0.63	0.47	0.24	0.75	3/32
11	1.62	0.63	0.47	0.24	0.75	3/32
22	2.50	1.00	0.72	0.36	1.25	5/32
33	3.00	1.16	0.97	0.425	1.56	3/16
36	3.00	1.16	0.97	0.425	1.56	3/16
42D	4.50	1.38	1.25	0.56	2.25	7/32
44	4.50	1.38	1.25	0.56	2.25	7/32
46	4.50	1.38	1.25	0.56	2.25	7/32

**90° or 180° Bumpers (090B, 180B)**

Bumpers are available to reduce noise and dissipate energy. This permits faster cycle times and increased production rates. Single vane units are available with 90° or 180° bumpers and double vane units are available with 90° bumpers.

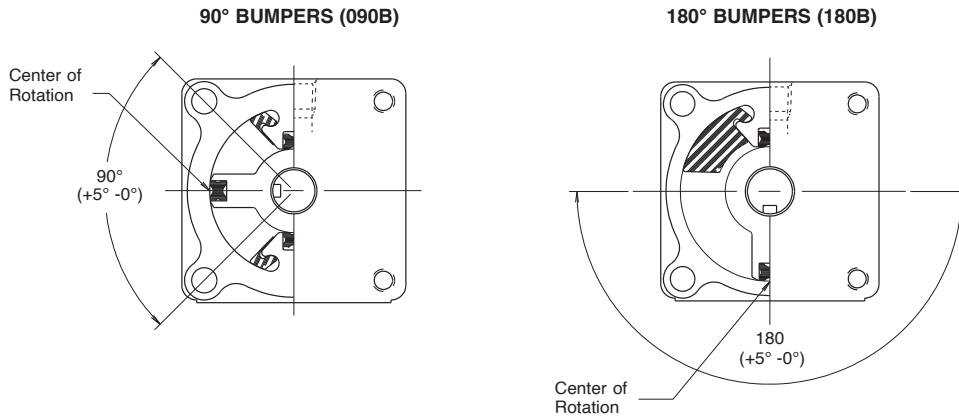

**90° or 180° Magnet (S)**

Option “S” provides a magnet(s) attached to the actuator shaft. Hall effect or reed switches sense the position of these magnets. The switches are available in two nominal rotations, 90° or 180°, and the adjustment is  $\pm 20^\circ$  for each switch to provide a total adjustment of  $\pm 40^\circ$ . Adjustable stops, “A”, or bumpers, “B”, can be supplied in addition to magnets. Order switches separately.

**Example Ordering Codes, Keyway Positions and Switch Sensing Locations:**

Please note the following keyway position and switch sensing locations, with respect to ordering codes and options, with porting at the 12:00 position as viewed from the output shaft end (as shipped from the factory).

**180S, 180AS, 180BS** - Single vane actuator with magnet or with magnet and stroke adjusters and/or bumpers: Keyway midstroke position at 6:00, magnet positioned to sense at 3:00 and 9:00.

**090S, 090AS** - Single vane actuator with magnet or with magnet and stroke adjusters: Keyway midstroke position at 6:00, magnet positioned to sense at 4:30 and 7:30.

**090S, 090AS, 090BS** - Double vane actuator with magnet or with magnet and stroke adjusters or bumpers; or single vane actuator with magnet and bumpers: Keyway midstroke position at 9:00, magnet positioned to sense at 7:30 and 10:30.

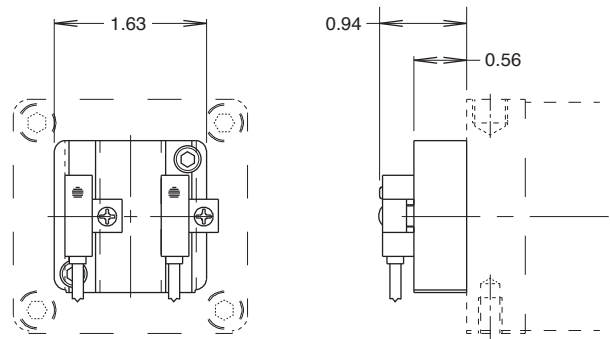

PV Series
PRN(A) Series
PTR Series
B671/F672 Series
HP Series
Rotary Actuators Products
<b>H</b>

Options

PV Series  
PRN(A) Series  
PTR Series  
B671/F672 Series  
HP Series  
Rotary Actuators Products  
H

**Rear Port (7)**

Rear porting provides convenience for confined mounting on very small units being face mounted.

This option is not available with switches or stroke adjustment. Consult factory for double end shaft option.

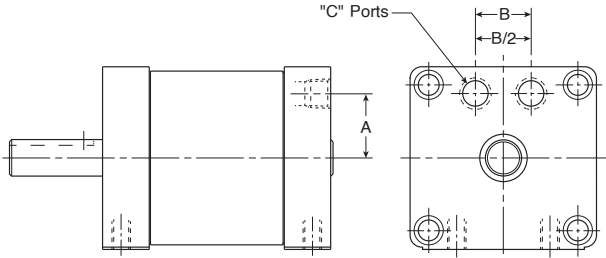

Model Number	A	B	C
10	0.54	0.50	10-32
11	0.54	0.50	10-32
22	0.88	0.75	1/8 NPTF
33	1.09	0.90	1/8 NPTF
36	1.09	0.90	1/8 NPTF
42D	1.68	1.00	1/4 NPTF
44	1.68	1.00	1/4 NPTF
46	1.68	1.00	1/4 NPTF

**Bearings - Radial Ball Bushings (L)**

Composite bushings should be used for washdown, highly contaminated, and low priced applications. Radial ball bushings provide greater precision. For bearing load capacities, reference the Engineering Data section of the catalog.

Consult factory for pricing and availability.

Composite Bushing

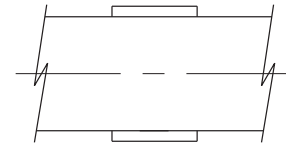

Radial Ball Bushing

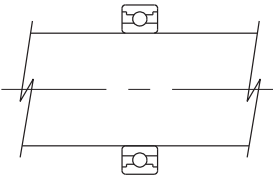

**Fluorocarbon Seals (V)**

Standard self-lubricating, abrasion resistant nitrile seals should be used for general purpose applications with temperatures of 0 to 180°F. Fluorocarbon seals are recommended for high temperature applications up to 250°F.

Option	Temperature Range* (°F)
Bumpers	0 - 200
Magnets	0 - 155
Switches	14 - 185

\*Consult factory for higher temperature operation.

**Solid State (Hall Effect) and Reed Sensors**

Sensors are available in a normally open or normally closed configuration.

Sensors must be ordered separately from the Electronic Sensors section.



For inventory, lead times, and kit lookup, visit [www.pdnplu.com](http://www.pdnplu.com)

PV Series
PRN(A) Series
PTR Series
B671/F672 Series
HP Series
Rotary Actuators Products
<b>H</b>

**PRN Series**

**PRNA Series – Miniature Sizes 1 to 20**

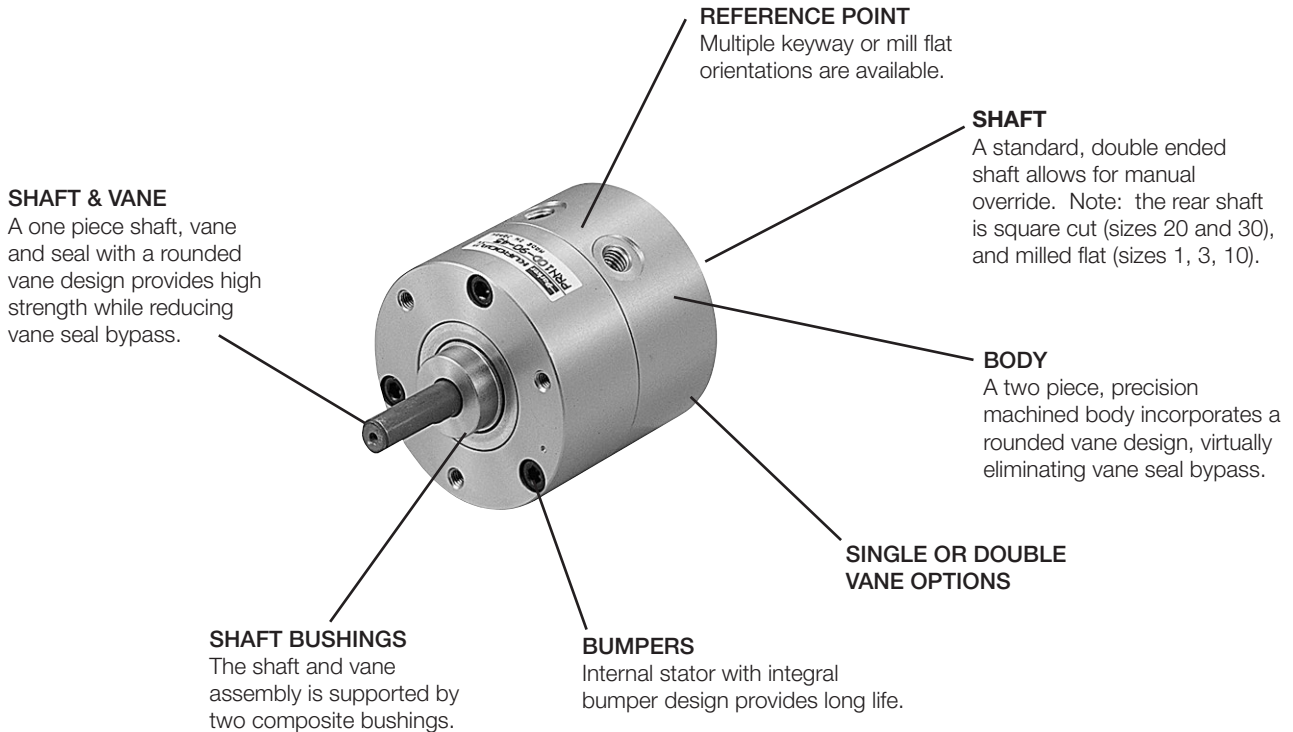

**PRN Series – Sizes 30 to 800**

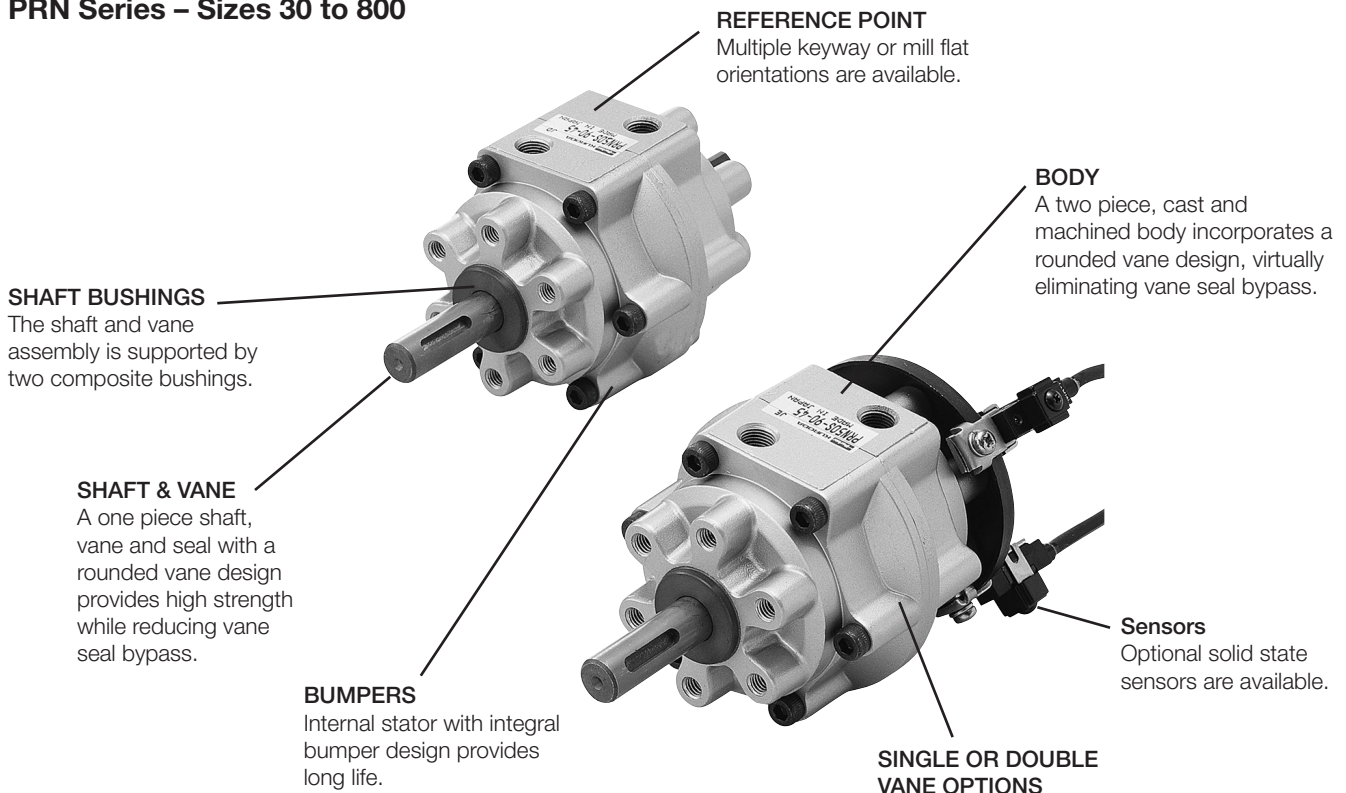

For inventory, lead times, and kit lookup, visit [www.pdnplu.com](http://www.pdnplu.com)

Features

- Single or double vane rotary actuator
- 3 standard rotations: 90°, 180°, or 270°
- Output torque @ 0.7 MPa:  
16 to 1120 N•cm (1.4 to 99 in-lb)
- Internal bumpers are standard
- Shock absorbers are available for high inertia loads



Operating information

Operating pressure:	100 PSIG (6.9 bar)
Temperature range:	-5°C to 80°C (-23°F to 176°F)
Filtration requirements:	40 micron, dry filtered air

Ordering information

**PRNA**      **20**      **S** - **90** - **90**      **S**

Type	
PRNA	Sizes 1-20
PRN	Sizes 30-800

Size
1
3
10
20
30
50
150
300
800

Type	
S	Single Vane
D	Double Vane

Porting	
Omit	Standard Porting
S	Rear Porting (sizes 3-20 only)

Rotation Angle	
90	90° (all sizes, single and double vane)
100	100° (sizes 50 through 800, double vane only)
180	180° (all sizes, single vane only)
270	270° (single vane only, not available on size 1)
280	280° (sizes 50 through 800, single vane only)

Oscillating Reference Point*	
40	40°
45	45°
90	90°

\* See specification tables for availability of rotation angle /reference point combinations for the selected model.

**Sensors**  
See section L for sensors.

Reference point and rotation orientations

**PRNA1S/D, PRNA3S/D, PRNA10S/D PRNA20S/D, PRN30S/D**  
Reference point at 45°

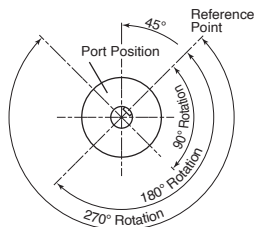

**PRN50, PRN150, PRN300, PRN800**  
Reference point at 45°

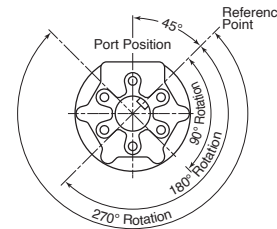

**PRN1AS, PRNA3S PRNA10S, PRNA20S**  
Reference point at 90°

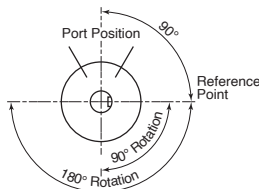

**PRN50, PRN150, PRN300, PRN800**  
Reference point at 40°

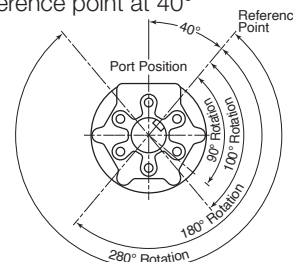

For inventory, lead times, and kit lookup, visit [www.pdnplu.com](http://www.pdnplu.com)

Specifications – Sizes 1 to 30

Quick reference data – PRNA miniature

Type	Model Number	Theoretical Output Torque				Maximum Breakaway Pressure	Unit Weight
		0.3 MPa (45 PSI)	0.5 MPa (75 PSI)	0.7 MPa (100 PSI)	1.0 MPa (145 PSI)		
		Ncm	Ncm	Ncm	Ncm	MPa	kg
Single Vane	PRNA1S	8	13	19	—	0.08	0.04
	PRNA3S	17	31	45	—	0.10	0.07
	PRNA10S	46	86	127	—	0.10	0.14
	PRNA20S	80	159	240	350	0.10	0.25
Double Vane	PRNA1D	17	28	41	—	0.10	0.04
	PRNA3D	32	54	76	—	0.07	0.07
	PRNA10D	101	168	235	—	0.07	0.15
	PRNA20D	165	330	530	800	0.06	0.26

Kinetic energy ratings and bearing load capacities – sizes 1 to 30

Model Number	Bearing Load Capacities		Distance Between Centerline Bearings	Maximum Kinetic Energy Rating
	Thrust Load	Radial Load		
	N	N	mm	mJ
PRNA1S	1	10	15	0.8
PRNA3S	4	40	20	4
PRNA10S	4	50	30	8
PRNA20S	25	300	42	40
PRN30S	30	400	48	67

Specifications

Model	Unit	PRNA1S			PRNA3S			PRNA10S			PRNA20S			PRN30S		
Rotational Tolerance	Degree	+4, -0	+4, -0	+4, -0	+4, -0	+4, -0	+4, -0	+4, -0	+4, -0	+4, -0	+4, -0	+4, -0	+4, -0	+4, -0	+4, -0	
Operating Pressure Range	MPa	0.3 to 0.7	0.3 to 0.7	0.3 to 0.7	0.2 to 0.7	0.2 to 0.7	0.2 to 0.7	0.2 to 0.7	0.2 to 0.7	0.2 to 0.7	0.2 to 1	0.2 to 1	0.2 to 1	0.2 to 1	0.2 to 1	
Temperature Range	°C	-5 to 80	-5 to 80	-5 to 80	-5 to 80	-5 to 80	-5 to 80	-5 to 80	-5 to 80	-5 to 80	-5 to 80	-5 to 80	-5 to 80	-5 to 80	-5 to 80	
Maximum Frequency*	cycle/min	300	180	70	260	160	60	240	150	100	210	120	60	180	90	60
Displacement	cm <sup>3</sup>	1.4	1.4	1.5	3.4	3.4	4	9.8	9.8	12	17	17	21	37	37	43

Model	Unit	PRNA1D			PRNA3D			PRNA10D			PRNA20D			PRN30D		
Rotational Tolerance	Degree	+4, -0			+4, -0			+4, -0			+4, -0			+4, -0		
Operating Pressure Range	MPa	0.3 to 0.7			0.2 to 0.7			0.2 to 0.7			0.2 to 1			0.2 to 1		
Temperature Range	°C	-5 to 80			-5 to 80			-5 to 80			-5 to 80			-5 to 60		
Maximum Frequency*	cycle/min	240			240			240			200			200		
Displacement	cm <sup>3</sup>	2			2.4			5			10			34		

\* Maximum frequency value given at a pressure of 0.5 MPa (73 psi) and under no load.

PV Series  
PRN(A) Series  
PTR Series  
B671/F672 Series  
HP Series  
Rotary Actuators Products



For inventory, lead times, and kit lookup, visit [www.pdnplu.com](http://www.pdnplu.com)



Specifications – Sizes 30 to 800

Quick reference data – PRN

Type	Model Number	Theoretical Output Torque				Maximum Breakaway Pressure	Unit Weight
		0.3 Mpa (45 PSI)	0.5 MPa (75 PSI)	0.7 MPa (100 PSI)	1.0 MPa (145 PSI)		
Single vane	<b>PRN30S</b>	180	319	480	720	0.10	0.47
	<b>PRN50S</b>	259	479	700	1060	0.10	0.8
	<b>PRN150S</b>	850	1500	2100	3050	0.08	2.0
	<b>PRN300S</b>	1650	2850	4050	5750	0.08	3.7
	<b>PRN800S</b>	5910	10200	14400	20500	0.05	13
Double vane	<b>PRN30D</b>	440	770	1120	1660	0.08	0.48
	<b>PRN50D</b>	579	1040	1510	2250	0.08	0.8
	<b>PRN150D</b>	1900	3500	4800	6900	0.06	2.0
	<b>PRN300D</b>	3900	6800	9700	1370	0.06	4.3
	<b>PRN800D</b>	12000	20600	28800	41100	0.05	13

Kinetic energy ratings and bearing load capacities – sizes 50 to 800

Model	Bearing Load Capacities			Maximum Kinetic Energy Rating		
	Thrust Load N	Radial Load N	Distance Between Centerline Bearings mm	Standard Unit J	Shock Absorber (per cycle) J	Shock Absorber (per cycle) J/hr
<b>PRN50S/D</b>	44.1	588	66	0.13	7.8	3100
<b>PRN150S/D</b>	88.2	1176	79.5	0.6	10	11300
<b>PRN300S/D</b>	147	1960	97.5	8.0	20	22000
<b>PRN800S/D</b>	490	4900	138.5	10.5	156	56500

Specifications

Model	Unit	PRN50S				PRN150S				PRN300S			
Rotational Tolerance	Degree	+3 -0	+3 -0	+3 -0	+3 -0	+3 -0	+3 -0	+3 -0	+3 -0	+3 -0	+3 -0	+3 -0	+3 -0
Operating Pressure Range	MPa	0.2 to 1.0	0.2 to 1.0	0.2 to 1.0	0.2 to 1.0	0.2 to 1.0	0.2 to 1.0	0.2 to 1.0	0.2 to 1.0	0.2 to 1.0	0.2 to 1.0	0.2 to 1.0	0.2 to 1.0
Temperature Range	°C	5 to 60	5 to 60	5 to 60	5 to 60	5 to 60	5 to 60	5 to 60	5 to 60	5 to 60	5 to 60	5 to 60	5 to 60
Maximum Frequency*	cycle/min	180	90	60	60	120	80	50	50	90	60	40	40
Displacement	cm <sup>3</sup>	51	51	61	62	146	146	179	185	244	283	352	365

Model	Unit	PRN800S				PRN50D		PRN150D		PRN300D		PRN800D	
Rotational Tolerance	Degree	+3, -0	+3, -0	+3, -0	+3, -0	+3, -0	+3, -0	+3, -0	+3, -0	+3, -0	+3, -0	+3, -0	
Operating Pressure Range	MPa	0.2 to 1.0	0.2 to 1.0	0.2 to 1.0	0.2 to 1.0	0.2 to 1.0	0.2 to 1.0	0.2 to 1.0	0.2 to 1.0	0.2 to 1.0	0.2 to 1.0	0.2 to 1.0	
Temperature Range	°C	5 to 60	5 to 60	5 to 60	5 to 60	5 to 60	5 to 60	5 to 60	5 to 60	5 to 60	5 to 60	5 to 60	
Maximum Frequency*	cycle/min	65	45	30	30	180	–	120	–	90	–	65	
Displacement	cm <sup>3</sup>	754	869	1036	1046	42	43	127	123	244	271	754	

\* Maximum frequency value given at a pressure of 0.5 MPa (73 psi) and under no load.



For inventory, lead times, and kit lookup, visit [www.pdnplu.com](http://www.pdnplu.com)



PRNA1S

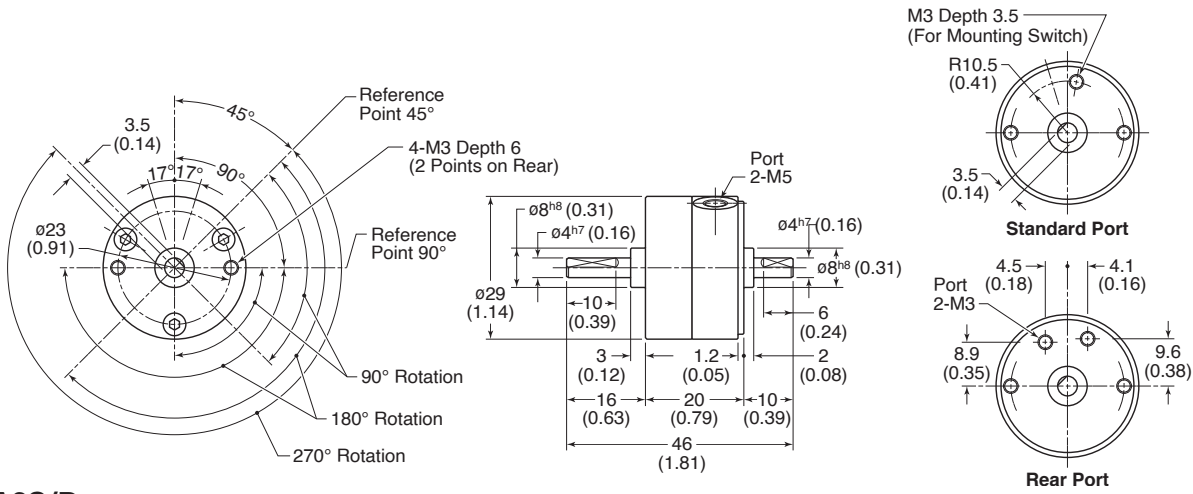

PRNA3S/D

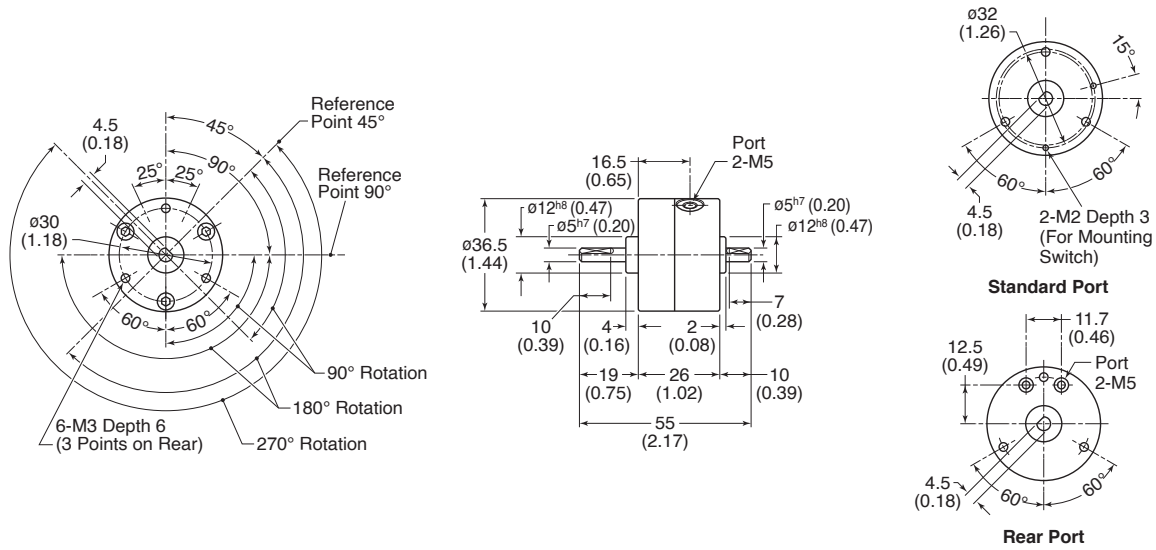

PRNA10S/D

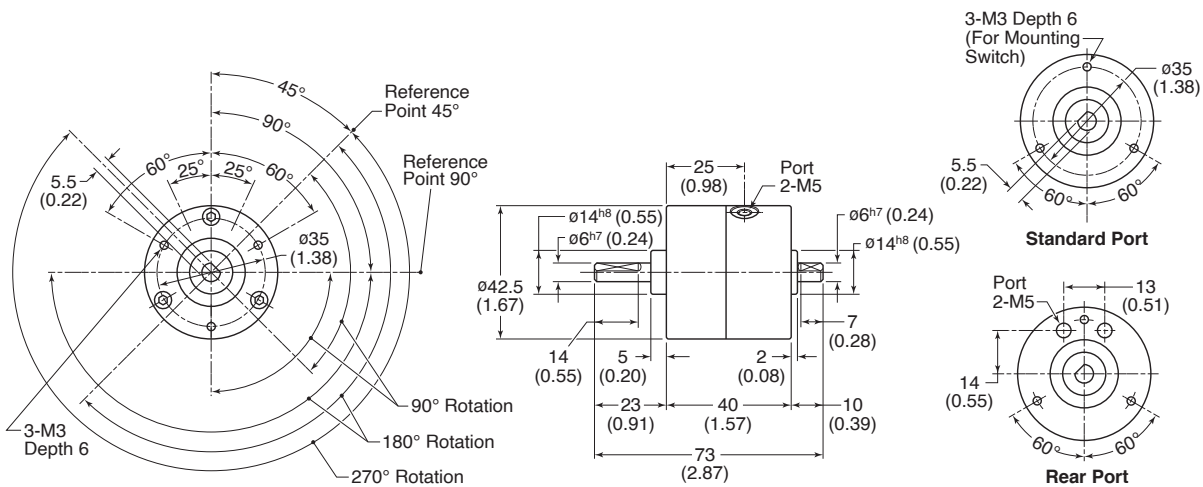

Dimensions in mm (inch)



For inventory, lead times, and kit lookup, visit [www.pdnplu.com](http://www.pdnplu.com)

H15

Parker Hannifin Corporation  
Pneumatic Division  
Wadsworth, Ohio  
[www.parker.com/pneumatics](http://www.parker.com/pneumatics)

PV Series  
PRN(A) Series  
PTR Series  
B671/F672 Series  
HP Series  
Rotary Actuators Products



PRNA20S/D

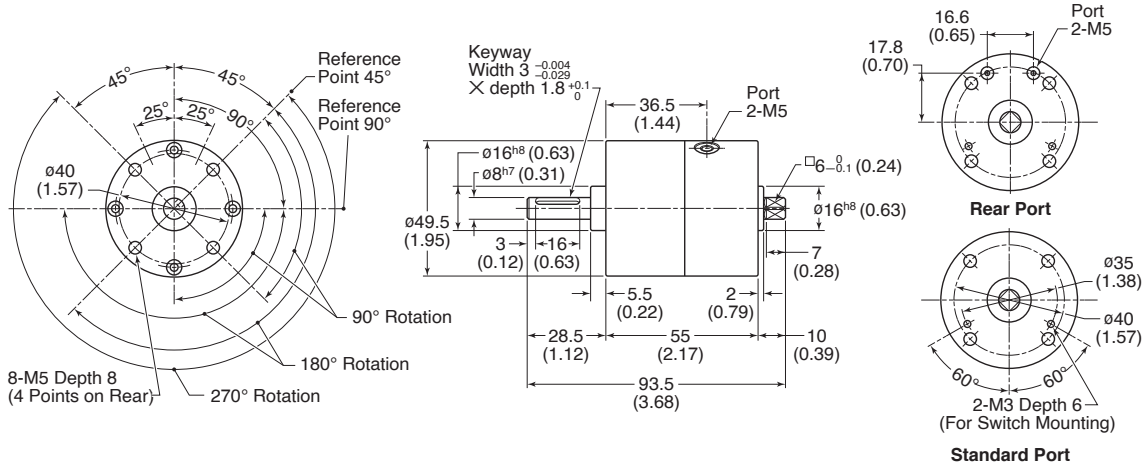

PRN30S/D

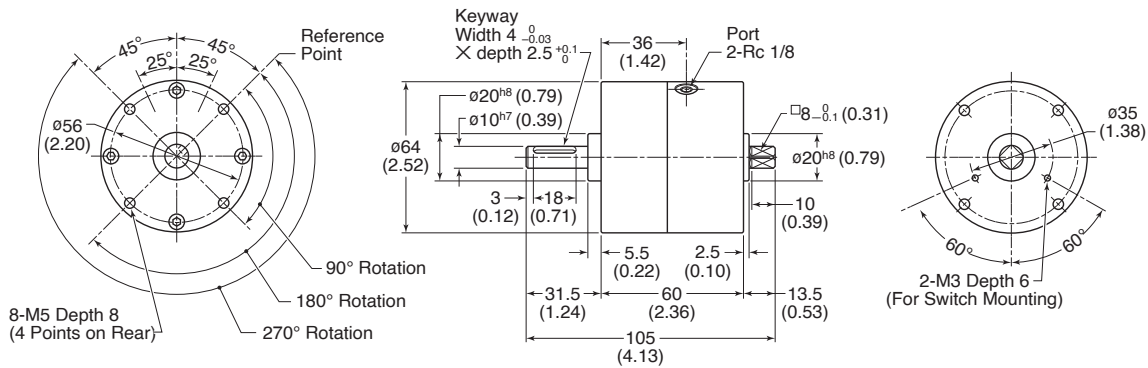

Dimensions in mm (inch)



For inventory, lead times, and kit lookup, visit [www.pdnplu.com](http://www.pdnplu.com)

H16

Parker Hannifin Corporation  
Pneumatic Division  
Wadsworth, Ohio  
[www.parker.com/pneumatics](http://www.parker.com/pneumatics)

PV Series  
PRN(A) Series  
PTR Series  
B671/F672 Series  
HP Series  
Rotary Actuators Products  
H

PRN Sizes 50 to 800

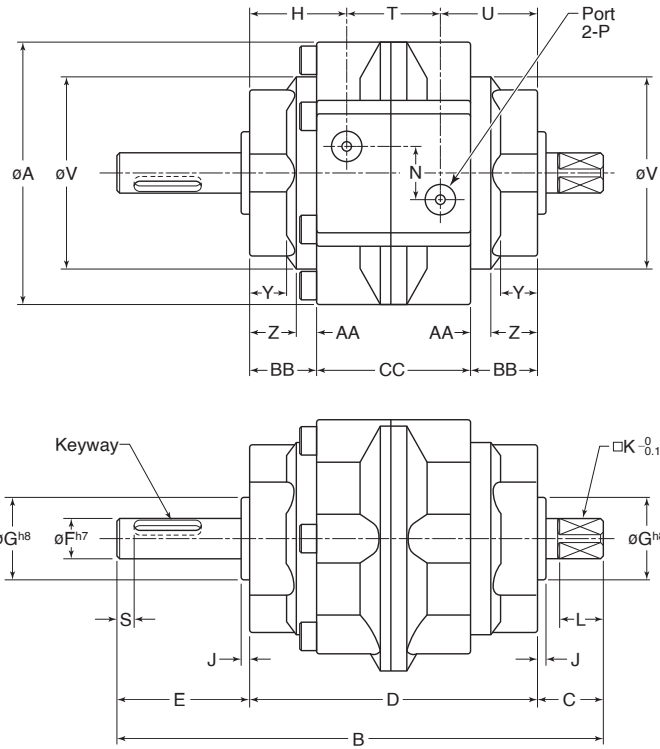
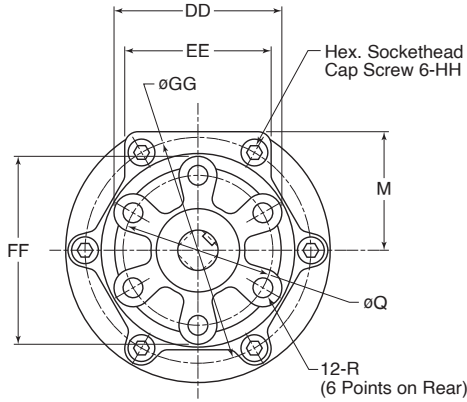

Model Number	A	B	C	D	E	F	G	H	J	K	L	M	N	P	Q	R	S
PRN50	79 (3.11)	145 (5.71)	19.5 (0.77)	86 (3.39)	39.5 (1.56)	12 (0.47)	25 (0.98)	29 (1.14)	2.5 (0.10)	10 (0.39)	13 (0.51)	36 (1.42)	16 (0.63)	Rc1/8	45 (1.77)	M6 x 1, Depth 9	5 (0.20)
PRN150	110 (4.33)	180 (7.09)	23.5 (0.93)	103 (4.06)	53.5 (2.11)	17 (0.67)	30 (1.18)	34.5 (1.36)	3 (0.12)	13 (0.51)	16 (0.63)	51 (2.01)	24 (0.94)	Rc1/4	70 (2.76)	M8 x 1.25, Depth 12	5 (0.20)
PRN300	141.5 (5.57)	220 (8.66)	30 (1.18)	125 (4.92)	65 (2.56)	25 (0.98)	45 (1.77)	41.5 (1.63)	3.5 (0.14)	19 (0.75)	22 (0.87)	66 (2.60)	32 (1.26)	Rc3/8	80 (3.15)	M10 x 1.5, Depth 15	5 (0.20)
PRN800	196 (7.72)	285 (11.22)	44.5 (1.75)	171 (6.73)	69.5 (2.74)	40 (1.57)	70 (2.76)	53.5 (2.11)	4.5 (0.18)	32 (1.26)	35 (1.38)	90 (3.54)	44 (1.73)	Rc1/2	120 (4.72)	M12 x 1.75, Depth 18	10 (0.39)

Model Number	T	U	V	Y	Z	AA	BB	CC	DD	EE	FF	GG	HH	Keyway Width x Depth x Length
PRN50	28 (1.10)	29 (1.14)	58 (2.28)	11 (0.43)	14 (0.55)	6 (0.24)	20 (0.79)	46 (1.81)	51 (2.01)	44 (1.73)	57 (2.24)	68 (2.68)	M5 x 30	4 <sup>0</sup> <sub>-0.03</sub> x 2.5 <sup>+0.1</sup> <sub>0</sub> x 20
PRN150	34 (1.34)	34.5 (1.36)	85.2 (3.35)	10.5 (0.41)	15.5 (0.61)	8 (0.31)	23.5 (0.93)	56 (2.20)	75 (2.95)	61 (2.40)	85 (3.35)	97 (3.82)	M6 x 35	5 <sup>0</sup> <sub>-0.03</sub> x 3 <sup>+0.1</sup> <sub>0</sub> x 36
PRN300	42 (1.65)	41.5 (1.63)	110 (4.33)	13 (0.51)	17.5 (0.69)	10 (0.39)	27.5 (1.08)	70 (2.76)	88.5 (3.48)	78 (3.07)	98.5 (3.88)	125 (4.92)	M8 x 45	7 <sup>0</sup> <sub>-0.03</sub> x 4 <sup>+0.1</sup> <sub>0</sub> x 40
PRN800	64 (2.52)	53.5 (2.11)	152 (5.98)	14.5 (0.57)	21.1 (0.83)	11.4 (0.45)	32.5 (1.28)	106 (4.17)	130 (5.12)	110 (4.33)	145 (5.71)	173 (6.81)	M12 x 70	12 <sup>0</sup> <sub>-0.043</sub> x 5 <sup>+0.2</sup> <sub>0</sub> x 40

mm (inch)

PV Series  
PRN(A) Series  
PTR Series  
B671/F672 Series  
HP Series  
Rotary Actuators Products



For inventory, lead times, and kit lookup, visit [www.pdnplu.com](http://www.pdnplu.com)

**Flange Mount – Sizes 1 to 30**

**Note:** Should not be used on rear face when rear ports (S) or switches are specified.

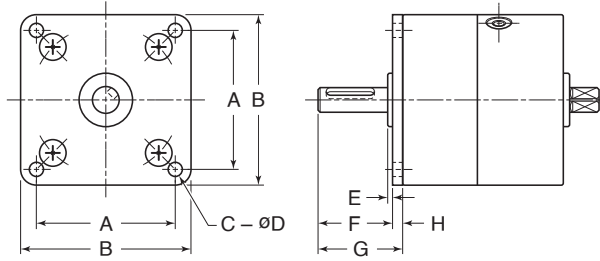

Part Number	A	B	C	D	E	F	G	H
PRNA1-P	24 (0.94)	30 (1.18)	4 (0.16)	3.4 (0.13)	1 (0.04)	14 (0.55)	16 (0.63)	2 (0.08)
PRNA3-P	30 (1.18)	37 (1.46)	4 (0.16)	3.4 (0.13)	1.5 (0.06)	16.5 (0.65)	19 (0.75)	2.5 (0.10)
PRNA10-P	34 (1.34)	42 (1.65)	4 (0.16)	3.5 (0.14)	1.8 (0.07)	19.8 (0.78)	23 (0.91)	3.2 (0.13)
PRNA20-P	41 (1.61)	50 (1.97)	4 (0.16)	5.5 (0.22)	1.9 (0.07)	24.9 (0.98)	28.5 (1.12)	3.6 (0.14)
PRN30-P	52 (2.05)	64 (2.52)	4 (0.16)	5.5 (0.22)	1.9 (0.07)	27.9 (1.10)	31.5 (1.24)	3.6 (0.14)

mm (Inches)

**Foot Mount – Sizes 1 to 30**

- Note:**
- A foot plate can be rotated in intervals of 90°.
  - Only one plate included. Two plates must be purchased to mount from both sides (as shown).
  - Should not be used on rear face when rear ports (S) or switches are specified.

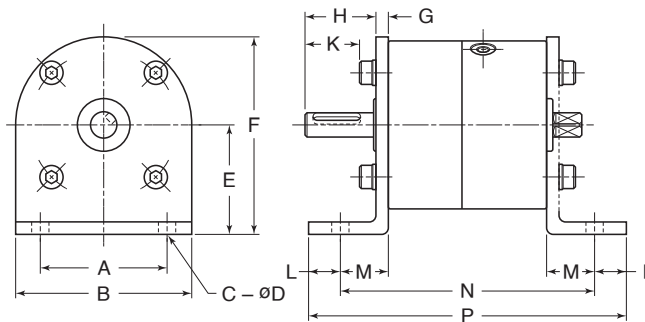

Part Number	A	B	C	D	E	F	G	H	K	L	M	N	P
PRNA1-L	20 (0.79)	30 (1.18)	2 (0.08)	4.8 (0.19)	22 (0.87)	37 (1.46)	2 (0.08)	14 (0.55)	10.3 (0.41)	5 (0.20)	10 (0.39)	40 (1.57)	50 (1.97)
PRNA3-L	26 (1.02)	36 (1.41)	2 (0.08)	4.8 (0.19)	25 (0.98)	43 (1.69)	2.6 (0.10)	16.4 (0.65)	12.7 (0.50)	7 (0.28)	11 (0.43)	48 (1.89)	62 (2.44)
PRNA10-L	30 (1.18)	42 (1.65)	2 (0.08)	5.8 (0.23)	30 (1.18)	51 (2.01)	3.2 (0.13)	19.8 (0.78)	16.1 (0.63)	8 (0.31)	12 (0.47)	64 (2.52)	80 (3.15)
PRNA20-L	36 (1.42)	49 (1.93)	2 (0.08)	7 (0.28)	34 (1.34)	58.5 (2.30)	3.6 (0.14)	24.9 (0.98)	18.6 (0.73)	10 (0.39)	15 (0.59)	85 (3.35)	105 (4.13)
PRN30-L	48 (1.89)	66 (2.60)	2 (0.08)	6.5 (0.26)	42 (1.65)	75 (2.95)	4.5 (0.18)	27 (1.06)	20.7 (0.81)	12 (0.47)	18 (0.71)	96 (3.78)	120 (4.72)

mm (Inches)



For inventory, lead times, and kit lookup, visit [www.pdnplu.com](http://www.pdnplu.com)

Flange Mount – Sizes 50 and 150

Note: A flange plate can be rotated in intervals of 60°

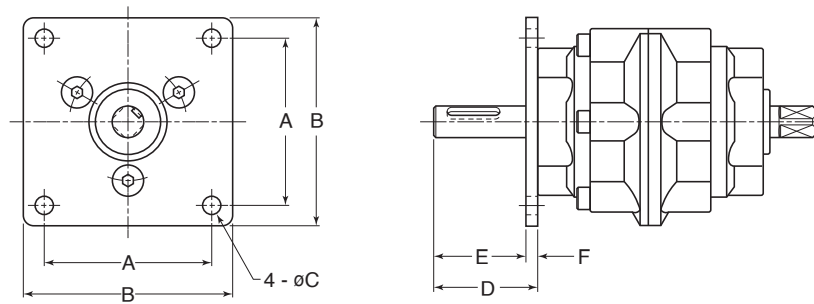

Part Number	A	B	C	D	E	F
PRN50-P	64 (2.52)	80 (3.15)	7 (0.28)	39.5 (1.56)	35 (1.38)	4.5 (0.18)
PRN150-P	88 (3.46)	110 (4.33)	9 (0.35)	53.5 (2.11)	47.5 (1.87)	6 (0.24)

mm (Inches)

Foot Mount – Sizes 50 to 800

Note: • A foot plate can be rotated in intervals of 60°.  
• Two foot plates (L2) are not available with the CR, FM, FC option.

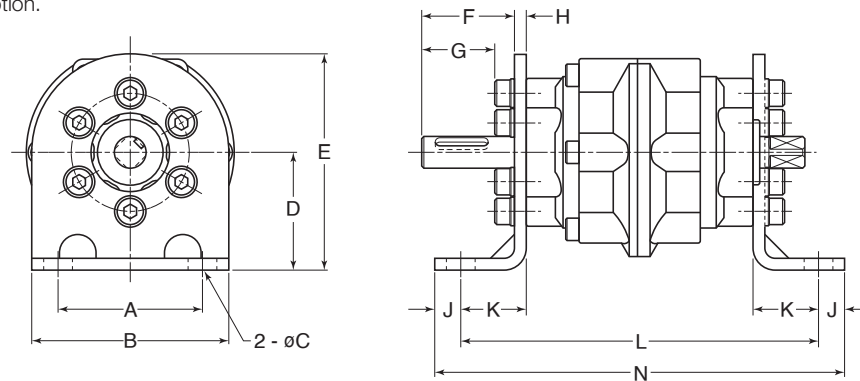

Part Number	A	B	C	D	E	F	G	H	J	K	L	N
PRN50-L	55 (2.17)	75 (2.95)	11 (0.43)	45 (1.77)	82.5 (3.25)	35 (1.38)	27.5 (1.08)	4.5 (0.18)	10 (0.39)	25 (0.98)	136 (5.35)	156 (6.14)
PRN150-L	80 (3.15)	110 (4.33)	13 (0.51)	65 (2.56)	115 (4.53)	43.5 (1.71)	33.5 (1.32)	10 (0.39)	12 (0.47)	28 (1.10)	159 (6.26)	183 (7.20)
PRN300-L	100 (3.94)	140 (5.51)	15 (0.59)	80 (3.15)	135 (5.31)	53 (2.09)	40.5 (1.59)	12 (0.47)	13 (0.51)	32 (1.26)	189 (7.44)	215 (8.46)
PRN800-L	140 (5.51)	200 (7.87)	15 (0.59)	110 (4.33)	200 (7.87)	54.5 (2.15)	39.5 (1.56)	15 (0.59)	15 (0.59)	35 (1.38)	241 (9.49)	271 (10.67)

mm (Inches)



For inventory, lead times, and kit lookup, visit [www.pdnplu.com](http://www.pdnplu.com)

PV Series  
PRN(A) Series  
PTR Series  
B671/F672 Series  
HP Series  
Rotary Actuators Products



**Shock Absorber**

The CRN Series Shock Absorber should be used in applications involving high inertial loads. Inertial loads are a result of any or all of the following:

- High cycle speeds
- Heavy loads
- Physically / dimensionally large loads

When any of these characteristics are present, it is important that some means of deceleration, such as the CRN, is used.

**Notes:**

- It is critical not to exceed the maximum kinetic energy values of the CRN. See chart below for kinetic energy calculations.
- When ordering a CRN, the shock absorber and the shock arm must be ordered separately.
- When a CRN is specified, maintain a minimum working pressure of 0.3 MPa.

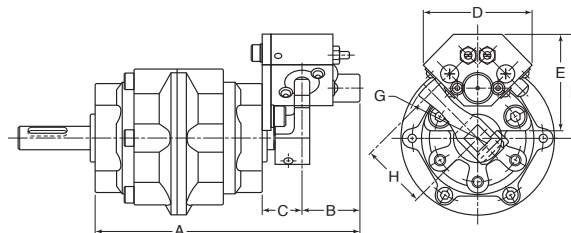

Part Number	A	B	C	D	E	F	G	H
<b>CRN50</b>	136.5 (5.37)	30 (1.18)	20.5 (0.81)	56 (2.20)	50 (1.97)	54 (2.13)	R38 (1.50)	34 (1.34)
<b>CRN150</b>	159.5 (6.28)	34 (1.34)	22.5 (0.89)	80 (3.15)	62 (2.44)	71.5 (2.81)	R51 (2.01)	46 (1.81)
<b>CRN300</b>	187.5 (7.38)	37 (1.46)	25.5 (1.00)	95 (3.74)	87 (3.43)	96 (3.78)	R68 (2.68)	62 (2.44)
<b>CRN800</b>	244 (9.61)	42 (1.65)	31 (1.22)	130 (5.12)	118 (4.65)	135 (5.31)	R78 (3.07)	90 (3.54)

mm (Inches)

**Shock Absorber Only**

<b>CRN50</b>	
<b>Model</b>	
<b>CRN50</b>	for PRN50
<b>CRN150</b>	for PRN150
<b>CRN300</b>	for PRN300
<b>CRN800</b>	for PRN800

**Shock Arm**

<b>CRN50</b>	
<b>Model</b>	
<b>CRN50</b>	for PRN50
<b>CRN150</b>	for PRN150
<b>CRN300</b>	for PRN300
<b>CRN800</b>	for PRN800

<b>90</b>	
<b>Rotation</b>	
<b>90</b>	90°
<b>100</b>	180°
<b>180</b>	180°
<b>270</b>	270°
<b>280</b>	280°

<b>45</b>		<b>T</b>	
<b>Reference Point</b>			
<b>40</b>	40°		
<b>45</b>	45°		

**Relationship Between Rotation and Reference Point**

Options	Rotation			
	90°	180°	270°	280°
<b>40°</b>	X	X	N/A	X
<b>45°</b>	X	N/A	X	N/A

**Note:** Select a shock arm based on the reference point and rotation of the PRN to be used.

Model No.	Unit	CRN50	CRN150	CRN300	CRN800
Kinetic Energy (per cycle)	J	7.8	10	20	156
	in-lb	68	85	170	1356
Maximum Angular Velocity	Degree/s	850	750	650	550
Kinetic Energy (per hour)	J/hr	3100	11300	22000	56500
	in-lb/hr	26939	98197	191180	490985
Temperature Range	°C	5 to 50	5 to 50	5 to 50	5 to 50
	°F	41 to 122	41 to 122	41 to 122	41 to 122
Deceleration Angle	Degree	11	12	14	15
Weight	g	240	420	780	1620
	lb	0.528	0.924	1.716	3.564



For inventory, lead times, and kit lookup, visit [www.pdnplu.com](http://www.pdnplu.com)

**Variable Position Solid State (FR Series) Sensor**

The FR Series variable position sensor provides the ability to adjust the sensor to sense along the full travel of the actuator. All switches and sensors must be ordered separately.

See the Electronic Sensors section for part numbers and sensor specifications.

**Note:** Not to be used in conjunction with rear ports (S).

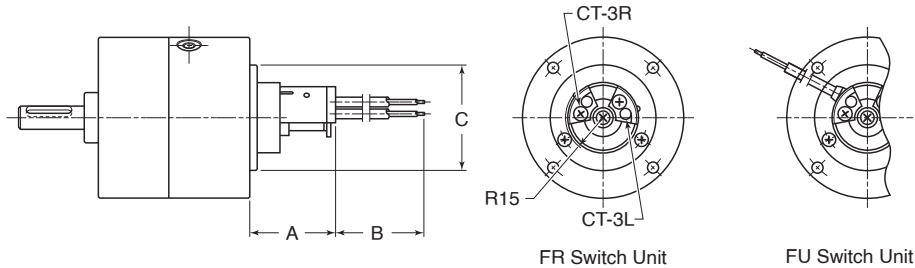

Model	A	B	C
PRNA1	31.9 (1.26)	1000 (39.37)	29 (1.14)
PRNA3	30.7 (1.21)	1000 (39.37)	35 (1.38)
PRNA10	34 (1.34)	1000 (39.37)	42 (1.65)
PRNA20	34 (1.34)	1000 (39.37)	42 (1.65)
PRN30	34 (1.34)	1000 (39.37)	42 (1.65)

mm (Inches)

**Fixed Position Solid State (SR / SU Series) Sensor**

The SR or SU Series fixed position sensor senses the end of stroke only. All switches and sensors must be ordered separately.

See the Electronic Sensors section for part numbers and sensor specifications.

**Note:** Not to be used in conjunction with rear ports (S).

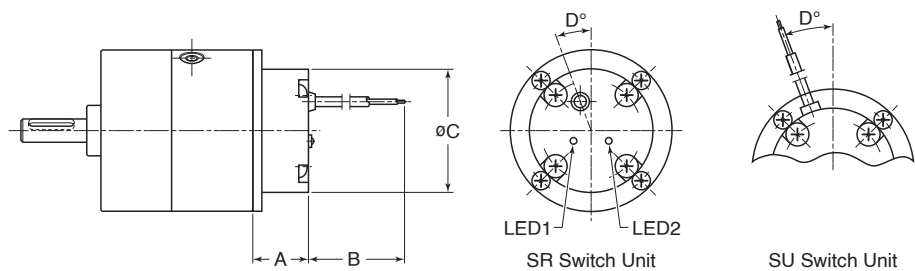

Model	A	B	C	D
PRNA1	N/A	N/A	N/A	N/A
PRNA3	18 (0.71)	1000 (39.37)	36 (1.42)	30 (1.18)
PRNA10	18.3 (0.72)	1000 (39.37)	42 (1.65)	25 (0.98)
PRNA20	18.3 (0.72)	1000 (39.37)	49 (1.93)	20 (0.79)
PRN30	21.8 (0.86)	1000 (39.37)	49 (1.93)	20 (0.79)

mm (Inches)

PV Series  
PRN(A) Series  
PTR Series  
B671/F672 Series  
HP Series  
Rotary Actuators Products

**H**



For inventory, lead times, and kit lookup, visit [www.pdnplu.com](http://www.pdnplu.com)

**Variable Position Solid State (FR / FC Series) Sensor**

The FR and FC Series variable position sensor provides the ability to adjust the sensor to sense along the full travel of the actuator. The FR Series sensor is to be used with the standard PRN sizes 50–800, and the FC Series sensor is to be used when a CRN Series shock absorber is specified.

See the Electronic Sensors section for part numbers and sensor specifications.

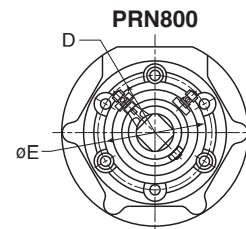
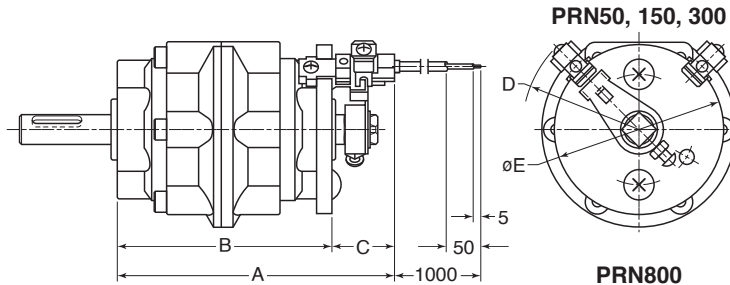

Model No.	A	B	C	D	E
PRN50	115 (4.53)	87.2 (3.43)	27.5 (1.08)	R47 (1.85)	69 (2.72)
PRN150	131.7 (5.19)	104.2 (4.10)	27.5 (1.08)	R61 (2.40)	97 (3.82)
PRN300	161.2 (6.35)	126.2 (4.97)	35 (1.38)	R69 (2.72)	113 (4.45)
PRN800	215.5 (8.48)	174.2 (6.86)	41.3 (1.63)	R60 (2.36)	108 (4.25)

mm (Inches)

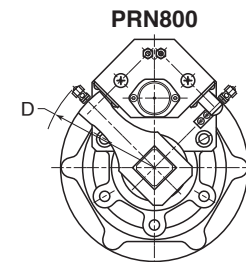
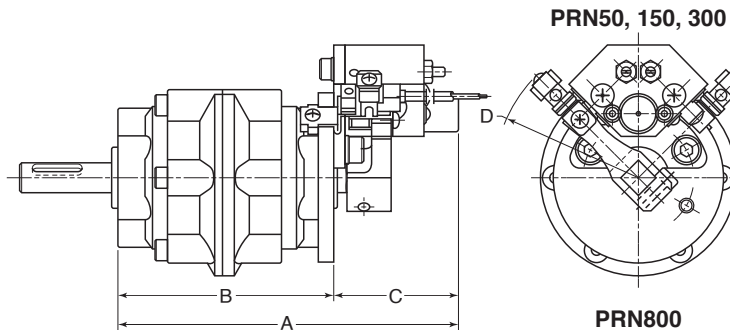

Model No.	A	B	C	D
PRN50	137.7 (5.42)	87.2 (3.43)	50.5 (1.99)	R58.2 (2.29)
PRN150	160.7 (6.33)	104.2 (4.10)	56.5 (2.22)	R72.2 (2.84)
PRN300	188.7 (7.43)	126.2 (4.97)	62.5 (2.46)	R88.2 (3.47)
PRN800	244 (9.61)	174.2 (6.86)	69.8 (2.75)	R118.5 (4.67)

mm (Inches)



For inventory, lead times, and kit lookup, visit [www.pdnplu.com](http://www.pdnplu.com)



**PTR Series**

**TUBING & BODY**

Aluminum is hard-coat anodized and permanently sealed for maximum wear resistance and long life.

**RACK & PINION**

Heavy duty gear design is made from through hardened chrome alloy steel for maximum strength and shock resistance. The gear chamber is prelubricated to provide millions of trouble-free cycles.

**PISTON SEALS**

Unique geometry of lipseal provides low breakaway pressure and long life. The specially formulated Nitroxile ELF compound incorporates a unique internal lubricant to provide the lowest breakaway and running friction, while maintaining the best wear resistance available. Can be operated with no added lubrication.

**SEALED BALL BEARINGS**

Reduce friction and breakaway pressure while providing substantial pinion and shaft support. This ensures a rigid and long lasting assembly, even for high cycle applications.

**STANDARD MALE KEYED SHAFT**

Is as large as possible to ensure superior strength; pinion and output shaft are one-piece to provide long life. A female shaft is available.

**PISTONS**

Floating Wear-Tech® aluminum pistons are supported at both ends by rugged filled PTFE wear bands which prevent cylinder scoring, galling, and binding. A magnet groove is standard on all pistons, allowing field conversion to position sensors.

**OPTIONAL "CHECK SEAL" CUSHIONS**

Unique molded flow passages combine the benefits of floating cushions with check valve action, providing effective cushioning and quick stroke reversal for higher cycle and production rates. This proven design eliminates failure-prone springs and ensures minimum wear. An adjustable needle valve and springless check valve allow exact "tailoring" of the cushion to match the application.

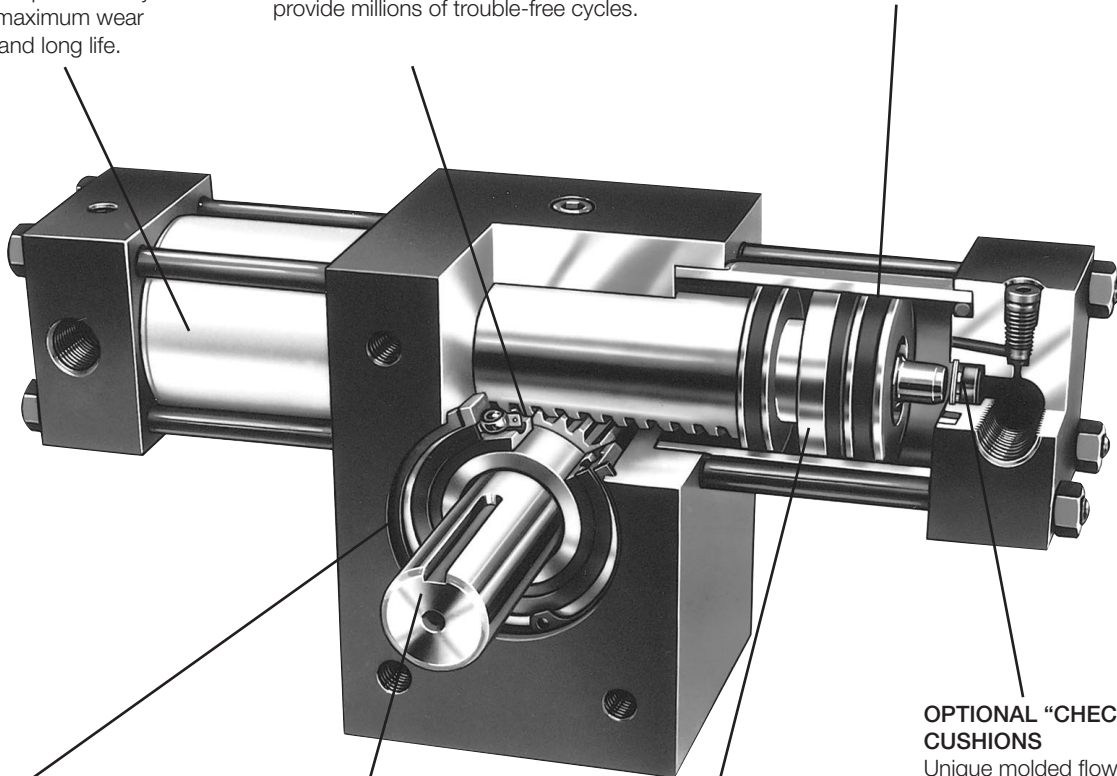

PV Series
PRN(A) Series
<b>PTR Series</b>
B671/F672 Series
HP Series
Rotary Actuators Products



Features

- Rack and pinion rotary actuator
- 5 bore sizes from 1" to 3-1/4"
- Output torque @ 100 PSIG: 39 lb-in to 2281 lb-in
- Standard rotations: 90°, 180°, 270°, 360°
- Available as single or double rack, 3 position, air/oil, antibacklash
- Optional bumpers, cushions, stroke adjusters, shock absorbers

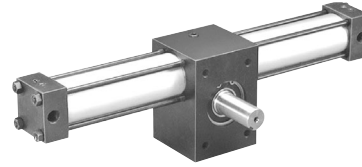

Operating information

Operating pressure:	250 PSIG (17 bar)
Temperature range:	
Nitrile seals	0°F to 180°F (-18° to 82°C)
Fluorocarbon seals	0°F to 250°F (-18° to 121°C)
Filtration requirements:	40 micron, dry filtered air

Sensors

See section L for sensors.



Ordering information

**PTR 25 1 - 090 3 F P - A B 2 1 M V - C**

<b>Model<sup>1</sup></b>	<b>Rotation<sup>2</sup></b>	<b>Mounting</b>	<b>Design Series</b>
10 1" Bore	090 90°	A Face/Base (standard)	C Current
15 1-1/2" Bore	180 180°	F Front Flange	
20 2" Bore	270 270°	G Foot Flange	
25 2-1/2" Bore	360 360°	P Pilot Ring	
32 3-1/4" Bore	Or Specify Any Other Rotation.	R Rear Flange	
		X Special	

<b>Configuration</b>	<b>Port Flow Controls</b>	<b>Seals</b>
1 Single Rack	Omit None	Omit Nitrile
2 Double Rack	P Flow Control Both Rotations	V Fluorocarbon
3 Three Position Actuator		X Special
6 Air/Oil Operation <sup>10</sup>		
7 Antibacklash		

<b>Cushion / Bumpers</b>	<b>Shaft</b>	<b>Standard Options</b>
Omit None	A Female, Inch Keyed	Omit None
3 Cushioned Both Rotations	B Single Male, Inch Keyed (Standard)	M Magnetic Piston Ring
4 Four Cushions <sup>4</sup>	C Double Male, Inch Keyed	S Shaft Seal Cover
7 Bumper Both Rotations	D Single Male, Metric Keyed	Q Prepped for External Air/Oil Tank <sup>10</sup>
9 Special	E Female, Metric Keyed	L Air/Oil Cushion & Flow Control Adj. At Location 1 (opposite standard)
	F Double Male, Metric Keyed	
	R Preload Keyway	
	X Special	

<b>Stroke Adjusters</b>	<b>Port Type</b>	<b>Port Location</b>
Omit None	1 SAE Straight Thread	1 Position 1 (standard)
F 0-30° Both Rotations <sup>5</sup>	2 NPTF	2 Position 2
L Shock/Stroke Adj. Both Rotations <sup>7,9,11</sup>	4 BSPP (ISO 1179-1 with ISO 228-1 Threads)	3 Position 3
X Special	9 Special	4 Position 4 <sup>8</sup>
		5 Position 5 <sup>6</sup>
		9 Special

Notes:

- Cylinder bore size. See appropriate tables for torque output.
- For 3-position units, specify middle and total rotation separated by a " / ", ie 090/180. To obtain equal rotation both sides of midstroke (theoretical 12:00), order unit with 5° longer rotation than standard with stroke adjusters.
- Double rack models only.
- Reduces to 10° with cushions.
- Not available with cushions or stroke adjusters.
- Stroke adjusters for option configuration compatibility.
- Not available on double rack models
- Not available with flow controls
- Not available with shocks
- Not available on size 32

<b>Other Options</b>
Detail in Clear Text:
• Proximity Sensors
• Feedback Potentiometer



For inventory, lead times, and kit lookup, visit [www.pdnplu.com](http://www.pdnplu.com)

**Quick reference data**

Model		Typ. Actual Output Torque @ 100 PSI (lb-in)	Theoretical Output Torque* (lb-in) Versus Input Pressure (PSI)				Displacement Per Degree Rotation (in <sup>3</sup> /°)	Maximum Angular Backlash (minutes)	Tolerance (degrees)
Single Rack	Double Rack		50	75	100	250			
101		35	19	29	39	98	0.007	60	-0, +5
	102	70	39	59	79	197	0.014	60	-0, +5
151		100	59	88	118	294	0.021	45	-0, +4
	152	200	118	177	236	590	0.042	45	-0, +4
201		250	141	212	282	705	0.049	35	-0, +3
251		375	215	322	430	1074	0.075	35	-0, +3
	202	500	282	423	565	1410	0.099	35	-0, +3
	252	750	430	644	859	2148	0.150	35	-0, +3
321		1000	570	856	1141	2852	0.199	25	-0, +2
	322	2000	1141	1711	2281	5703	0.398	25	-0, +2

\* Allow 10% for friction loss. Allow 20% on air/oil units. Use the single rack torque values for all air/oil, three position, and anti-backlash actuators.

**Bearing load capacities and kinetic energy ratings**

Model	Bearing Load Capacities* (lb)		Distance Between Bearings	Maximum Kinetic Energy Absorption Rating for Models Based on Configuration (lb-in)			
	Radial	Thrust		Standard or Stroke Adjusters	Bumper	Cushion**	Shock Absorbers (per cycle / per hour)
10	100	50	1.40	0.5	0.75	5.00	15/150,000
15	250	125	2.15	1.50	2.25	15.00	35/200,000
20	500	250	2.15	3.00	4.50	35.00	140/350,000
25	750	375	2.50	5.50	8.25	55.00	140/300,000
32	1000	500	3.75	12.00	18.00	155.00	N/A

\* Bearing capacities only. Check Kinetic Energy ratings to determine if actuator will stop load.

\*\* Assuming positive back pressure provided by meter-out flow control.

PV Series  
 PRN(A) Series  
 PTR Series  
 B671/F672 Series  
 HP Series  
 Rotary Actuators Products  
**H**



For inventory, lead times, and kit lookup, visit [www.pdnplu.com](http://www.pdnplu.com)

H25

**Parker Hannifin Corporation**  
 Pneumatic Division  
 Wadsworth, Ohio  
[www.parker.com/pneumatics](http://www.parker.com/pneumatics)

PV Series  
 PRN(A) Series  
 PTR Series  
 B671/F672 Series  
 HP Series  
 Rotary Actuators Products  
**H**

### Kinetic Energy Calculations

In many cases, the size and life of a rotary actuator is determined not by its torque output, but rather by its energy dissipation capability. This is based on the assumption that if the actuator is capable of stopping the load, it is certainly capable of starting the load.

Both torque output and kinetic energy absorption must be considered if the actuator physically stops the load.

To calculate Kinetic Energy, the following variables are required:

1. Rotational Mass Moment of Inertia ( $J_m$ ) - See next page.
2. Total Rotation (Degrees)
3. Rotation Time (Seconds)

### KINETIC ENERGY BASIC FORMULA

$$KE = 1/2 J_m \omega^2$$

$$\omega = 0.035 \times \frac{\text{Angle Traveled (deg.)}}{\text{Rotation Time (sec.)}}$$

where

KE = Kinetic Energy (in-lb)

$J_m$  = Rotational Mass Moment of Inertia (in-lb-sec<sup>2</sup>)

See next page for formulas.

$\omega$  = Peak Velocity (rad/sec)

(Assuming twice average velocity)

### Unit Weights (lb)

Model	Rotation			
	90°	180°	270°	360°
PTR101	2-1/4	2-1/2	2-3/4	3
PTR102	3-1/2	3-7/8	4-1/4	4-5/8
PTR151	8-1/4	8-3/4	9-1/4	9-3/4
PTR152	11-3/8	12-3/8	13-3/8	14-3/8
PTR201	13-5/8	14-5/8	15-5/8	16-3/4
PTR202	19-3/4	21-7/8	24	26-1/8
PTR251	21-1/8	22-3/4	24-3/8	26
PTR252	30-3/4	34	37-1/4	40-1/2
PTR321	44-1/4	46-5/8	49	51-3/8
PTR322	61-7/8	66-5/8	71-3/8	76-1/8

### Seal kit ordering information

- Standard units are equipped with Nitrile seals.
- Optional seal compounds are available.
- Seal kit part numbers as shown:

<b>PSK</b> Parker Seal Kit	—	<b>PTR322</b> Base Model	<b>V</b>
			<b>Omit</b> Standard
			<b>V</b> Fluorocarbon
			<b>Q</b> Quad Ring Piston Seals
			<b>W</b> Carboxilated Nitrile Piston Seals

**Kinetic Energy Basic Formula**

$$KE = 1/2 Jm\omega^2$$

$$\omega = 0.035 \times \frac{\text{Angle Traveled (Deg.)}}{\text{Rotation Time (Sec.)}}$$

where:

KE = Kinetic Energy (in-lb)

Jm = Rotational mass moment of inertia (in-lb-sec<sup>2</sup>)  
 (Dependent on physical size of object and weight)

$\omega$  = Peak Velocity (rad/sec) (Assuming twice average velocity)

W = Weight of load (lb)

g = Gravitational constant = 386.4 in/sec<sup>2</sup>

k = Radius of gyration (in)

**Moments of Inertia**

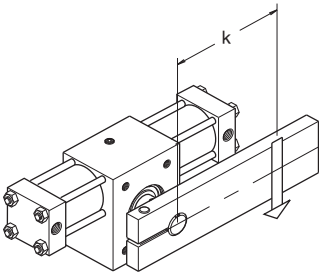
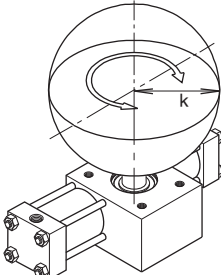
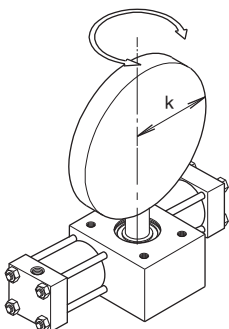
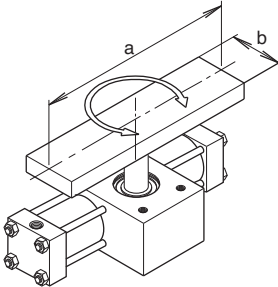
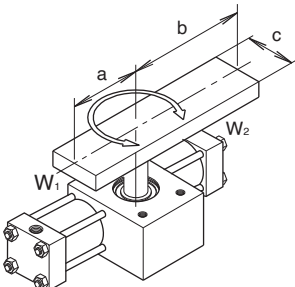
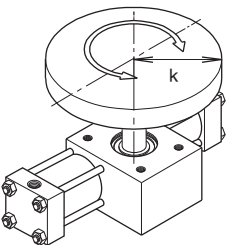
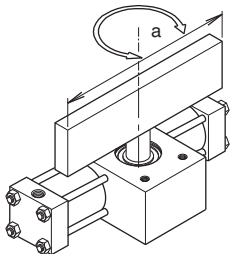
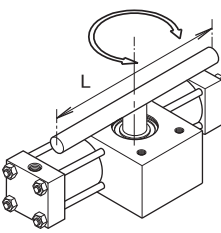
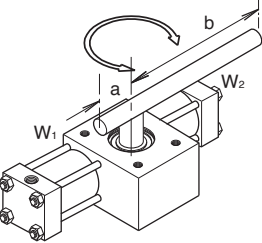
<p><b>POINT LOAD</b></p>  $Jm = \frac{W}{g} \times k^2$	<p><b>SOLID SPHERE -</b>                      Mounted on center</p>  $Jm = \frac{2}{5} \times \frac{W}{g} \times k^2$	<p><b>THIN DISK -</b>                      End mounted on center</p>  $Jm = \frac{W}{g} \times \frac{k^2}{4}$
<p><b>THIN RECTANGULAR PLATE -</b>                      Mounted on center</p>  $Jm = \frac{W}{g} \times \frac{a^2 + b^2}{12}$	<p><b>THIN RECTANGULAR PLATE -</b>                      Mounted off center</p>  $Jm = \frac{W_1}{g} \times \frac{4a^2 + c^2}{12} + \frac{W_2}{g} \times \frac{4b^2 + c^2}{12}$	<p><b>THIN DISK -</b>                      Mounted on center</p>  $Jm = \frac{W}{g} \times \frac{k^2}{2}$
<p><b>THIN RECTANGULAR PLATE -</b>                      End mounted on center</p>  $Jm = \frac{W}{g} \times \frac{a^2}{12}$	<p><b>SLENDER ROD -</b>                      Mounted on center</p>  $Jm = \frac{W}{g} \times \frac{L^2}{12}$	<p><b>SLENDER ROD -</b>                      Mounted off center</p>  $Jm = \frac{W_1}{g} \times \frac{a^2}{3} + \frac{W_2}{g} \times \frac{b^2}{3}$

PV Series
PRN(A) Series
PTR Series
B671/F672 Series
HP Series
Rotary Actuators Products
<b>H</b>



**Standard Face Base Mount (A) and Male Keyed Shaft (B)**

Double Male Keyed Shaft (C) shown in phantom

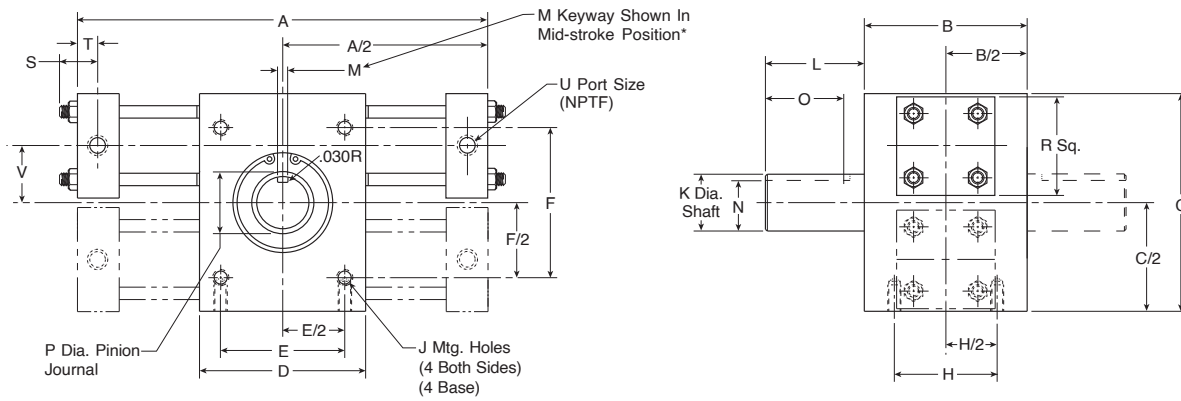

Model Number	Rotation (Degrees)	A	B	C	D	E	F	H	J	K	L	M	N
10	90°	6-11/16											
	180°	8-1/4	2	3	2	1.500	2.000	1.500	1/4-20 x 3/8 DP	0.500 0.499	7/8	0.125 0.127	0.430 0.425
	360°	11-7/16											
15	90°	9-1/8											
	180°	11-3/16	3	4-1/4	3	2.000	3.000	2.000	5/16-18 x 1/2 DP	0.875 0.874	1-7/8	0.188 0.190	0.771 0.761
	360°	15-3/8											
20	90°	11-3/16											
	180°	14-1/16	3	5	4	2.500	3.500	2.000	3/8-16 x 1/2 DP	1.125 1.124	1-7/8	0.250 0.252	0.986
	360°	19-11/16											
25	90°	12-9/16											
	180°	15-1/2	3-1/2	6	4	2.500	4.500	2.000	1/2-13 x 3/4 DP	1.375 1.374	2-1/4	0.313 0.315	1.201 1.191
	360°	20-5/8											
32	90°	16-5/8											
	180°	21-1/8	5	8	5	3.000	5.000	2.500	3/4-10 x 1 DP	1.750 1.749	3-1/2	0.375 0.377	1.542 1.532
	360°	29-3/8											

Model Number	O	P	R	S	T	U	V
10	5/8	0.59	1-1/2	1/4	0.31	1/8	3/4
15	1-1/2	0.98	2	5/16	0.41	1/4	1-1/16
20	1-1/2	1.18	2-1/2	3/8	0.41	1/4	1-1/4
25	1-3/4	1.38	3	3/8	0.41	1/4	1-1/2
32	3	1.77	3-3/4	7/16	0.56	3/8	1-15/16

\* To obtain equal rotation both sides of midstroke (theoretical 12:00), order 5° longer rotation than standard with stroke adjusters.

**Mounting Options (F, G, P, R)**

**Foot Flange (G)**

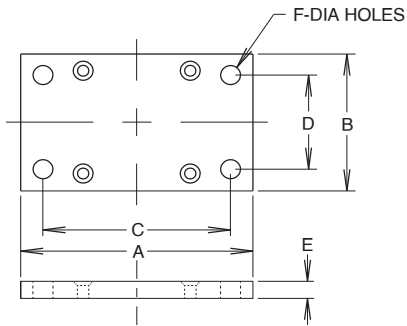

**Note:** Actuators are shipped with mounting flange installed unless otherwise noted.

Model	A	B	C	D	E	F
10	3.25	2.00	2.625	1.375	0.250	0.281
15	4.50	3.00	3.875	2.125	0.438	0.406
20	4.50	4.00	3.875	3.375	0.438	0.406
25	5.50	4.00	4.500	3.000	0.438	0.531
32	8.00	5.00	6.500	3.500	0.750	0.781

**Pilot Ring (P)**

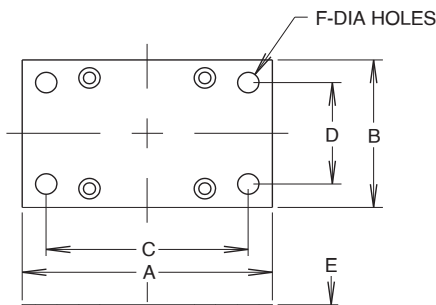

Model	A	B
10	1.124	0.125
15	2.000	0.25
20	2.167	0.25
25	2.679	0.25
32	3.348	0.25

**Front Flange (F)**  
**Rear Flange (R)**

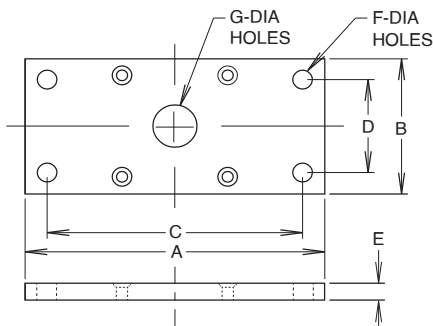

Model	A	B	C	D	E	F	G
10	4.25	2.00	3.625	1.375	0.250	0.281	0.625
15	5.75	3.00	5.125	2.125	0.438	0.406	1.000
20	6.50	4.00	5.875	3.375	0.438	0.406	1.250
25	8.25	4.00	7.250	3.000	0.438	0.531	1.625
32	12.00	5.00	10.000	3.000	0.750	0.781	2.000

**Shaft Options (C, A, R)**

Units are equipped standard with single male keyed shaft (B). Double male keyed (C) also available as shown on page H24. Also available in female keyed and preload keyway options.

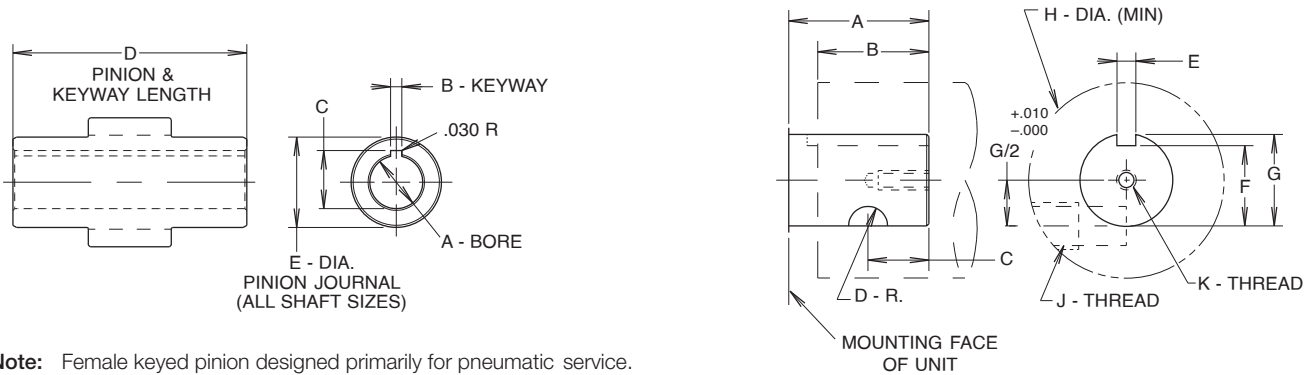

**Note:** Female keyed pinion designed primarily for pneumatic service. Review shaft stresses before applying on hydraulic service.

**Female Keyed (A)**

Model	A	B	C	D	E
10	0.375	0.093	0.417	1-13/32	0.59
	0.377	0.095	0.422		
15	0.500	0.125	0.560	2-11/16	0.98
	0.502	0.127	0.565		
20	0.750	0.187	0.837	2-23/32	1.18
	0.752	0.189	0.847		
25	1.000	0.250	1.083	3-1/8	1.38
	1.002	0.252	1.093		
32	1.250	0.250	1.367	4-9/16	1.77
	1.252	0.252	1.377		

**Preload Key (R)**

Model	A	B	C	D	E	F	G	H	J	K
10	7/8	5/8	0.375	0.156	0.125	0.430	0.500	1-1/2	3/8-24	10-32 x 3/8 DP
					0.127	0.425	0.499			
15	1-7/8	1-1/2	0.812	0.219	0.188	0.771	0.875	2	1/2-20	5/16-24 x 1/2 DP
					0.190	0.761	0.874			
20	1-7/8	1-1/2	0.812	0.250	0.250	0.986	1.125	3	5/8-11	3/8-24 x 9/16 DP
					0.252	0.976	1.124			
25	2-1/4	1-3/4	1.000	0.250	0.313	1.201	1.375	3-1/2	3/4-10	3/8-24 x 9/16 DP
					0.315	1.191	1.374			
32	3-1/2	3	1.500	0.437	0.375	1.542	1.750	4	1-8	1/2-20 x 3/4 DP
					0.377	1.532	1.749			

**Port Size and Location (1, 2, 3, 4)**

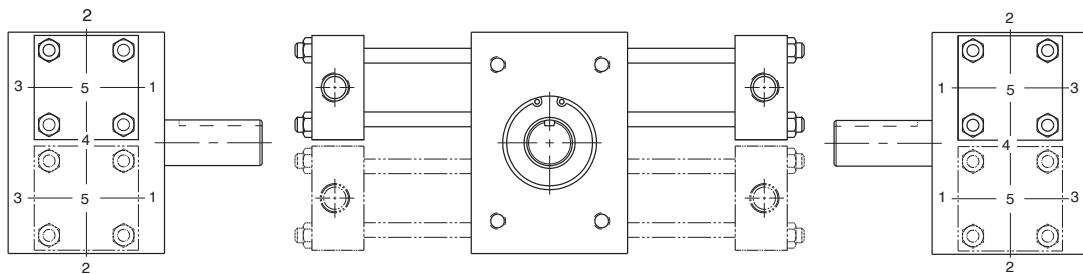

**Notes:**

1. Port position 1 is standard.
2. Port positions 2, 3 and 4 are standard options available at no additional cost.
3. Port position 4 is for single rack only.
4. Port position 5 is not available with cushions or stroke adjusters.

Model	Optional SAE Straight Thread (1)	Standard NPT (2)
10	7/16 - 20 (SAE 4)	1/8
15	7/16 - 20 (SAE 4)	1/4
20	9/16 - 18 (SAE 6)	1/4
25	9/16 - 18 (SAE 6)	1/4
32	3/4 - 16 (SAE 8)	3/8



**Cushions (3, 4)**

The standard cushions operate over the last 30° of rotation in either or both directions. A floating bushing ensures no binding of the cushion spear. For severe operating conditions, four cushions can be fitted on double rack units. All cushions are fully adjustable. On double rack units, cushions will be located on the upper cylinder.

For double rack units where Option 4 (four cushions) is selected please take special care to make sure that adjacent cushions (ie both C-1 ports) are adjusted to the same cushion setting so as to ensure that both cushions are working together. An improper setting could result in one of the cushions not being utilized and thus result in premature gear train life or other damage to the unit.

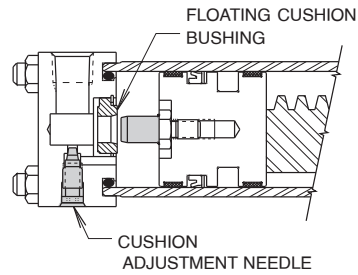

**Standard Cushion Needle Locations**

(Reference diagram on previous page)

Port Position	Cushion Position
1	2
2	3
3	2
4*	3
5	N/A

\*Single Rack only

**Bumpers (7)**

Built-in polyurethane bumper pads absorb shock and noise, thus permitting faster cycle times and increased production rates. Bumpers are available for pneumatic service only.

**Notes:**

1. Available with or without stroke adjusters
2. Not available with cushions

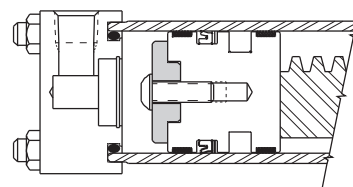

**Bumper Thickness**

Add the bumper thickness to overall unit length "A" for each bumper specified.

Model	Bumper Only	Bumper With Stroke Adjuster
10	0.13	0.44
15	0.19	0.63
20	0.25	0.75
25	0.25	0.75
32	0.25	1.00

PV Series

PRN(A) Series

PTR Series

B671/F672 Series

HP Series

Rotary Actuators Products

**H**

Options – Stroke Adjusters

PV Series  
 PRN(A) Series  
 PTR Series  
 B671/F672 Series  
 HP Series  
 Rotary Actuators Products  
**H**

**Stroke Adjusters (F) 30°**

Stroke adjusters will reduce angle of rotation by 30°. Typical applications are for initial set-up purposes where exact rotation cannot be pre-determined or when rotation requirements may change between various operations. Not available with port position 5.

**Notes:**

- Standard cushions operate over the last 30° of rotation. Stroke adjusters will decrease the effective cushion length by the same amount. For example, reducing the rotation by 5° yields a 25° cushion length. For effective cushions it is recommended that stroke adjustment not exceed 10° when used in conjunction with cushions.
- Maximum unit rotation is equal to rotation specified in model code. Adjusters allow rotational positioning equal to or less than the maximum rotation.
- 30° Stroke Adjusters are available with or without cushions. Double rack units will have cushions on upper rack and adjusters on lower rack. Single rack units with cushions (and double rack units with four cushions) and stroke adjusters will require additional "A" length.
- Antibacklash can be achieved on double rack units with stroke adjusters as long as extra rotation is ordered.
- When ordering cushions and stroke adjusters, the maximum adjustment is 10° per side.

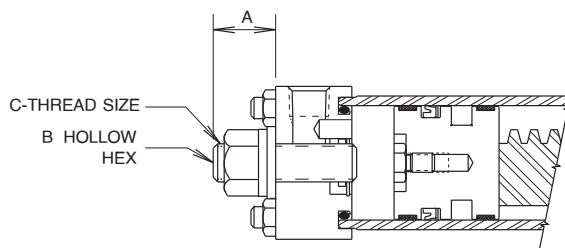

Model	(1) Turn Adj.	30° Adjustment W/O Cushioned End Cap, A (max)	10° Adjustment W/ Cushioned End Cap, A (max)	B	C
10	4.0°	0.63	0.38	1/8	1/4-28 UNF
15	4.6°	0.88	1.13	1/4	1/2-20 UNF
20	3.2°	1.13	1.13	1/4	1/2-20 UNF
25	3.2°	1.13	1.18	1/4	1/2-20 UNF
32	2.4°	1.50	2.13	3/8	3/4-16 UNF

**Shock / Stroke Adjusters (L)**

Hydraulic shock absorbers reduce noise and allow increased operating speeds and loads while also providing adjustability for end of rotation position. Shocks are fixed orifice self-compensating type and will provide constant deceleration despite changing energy conditions.

**Notes:**

- Not available on Model 32 or with port position 5.
- This option is not available in combination with the following options:
  - Air/Oil (6)
  - External Air/Oil (Q)
  - Bumper (7)
  - Cushions (3, 4)
  - Port Flow Control (P)
  - End Cap Mounted Proximity Sensors
 (Tie rod mounted reed and Hall effect sensors can be specified.)

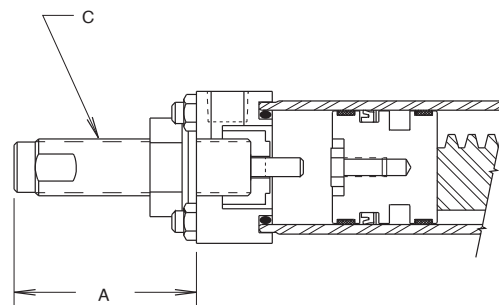

Model	(1) Turn Adjustment	A (max)	Max. Adjustment	C Thread Size
10	6°	2.20	110°	9/16 - 18 UNF
15	5°	2.40	80°	3/4 - 16 UNF
20	5°	3.66	130°	1 - 12 UNF
25	5°	3.66	130°	1 - 12 UNF



For inventory, lead times, and kit lookup, visit [www.pdnplu.com](http://www.pdnplu.com)

**Three Position Actuator (3)**

In addition to the standard two position actuators, three position units are also available. All standard options are also available.

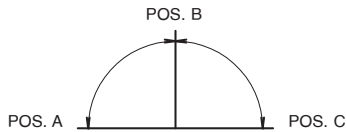

**Operation:**

A standard double rack unit is fitted with stop tubes on the upper rack. Pressurizing port C-2 (with ports C-1, C-3 exhausted) causes counter-clockwise pinion rotation to angular position A. Alternately applying pressure to C-1 (with C-2, and C-4 exhausted) will cause clockwise rotation to angular position C. Both positions A and C are at end of stroke, thus typical end cap options such as cushions, bumpers, and stroke adjusters will operate at these positions only.

Position B is obtained by pressurizing all ports. Pressure applied to the upper floating pistons centers the rack between the stop tubes, rotating the pinion to position B. The lower rack is free floating as the forces are equal on both ends.

**Dimensional Data:**

Three position actuator dimensions are identical to the standard double rack units. If stroke adjusters are specified they will be fitted to the upper rack, flow controls and cushions will be on the lower rack. Rotational tolerances are given in the chart at the right.

**Output Torque:**

Output torque of the multiple position actuator is equivalent to the torque output of the same size single rack unit. The chart to the right gives selected torque values for specified pressures.

**Ordering Information:**

Three position actuators can be ordered by inserting a 3 into the “configuration” space in the model code. The desired middle and total rotation should be stated in the model code separated by a “/”. The beginning position, 0°, need not be specified.

For example: **PTR153-045/180F-AB21-C** is a standard pneumatic actuator, three position, with an output torque of 118 lb-in at 100 psi. Position A is 0°, position B is 45°, and position C is 180°. Both positions A and C are adjustable by 30°, as the stroke adjuster option “F” was ordered.

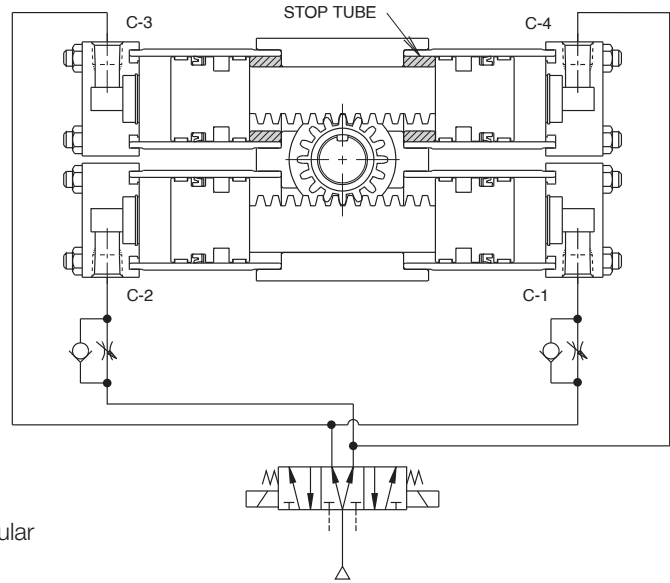

**Rotational Tolerances**

Model	Total Rotation, Degrees	Between Positions, Degrees <sup>1</sup>	Backlash, Minutes <sup>2</sup>
103	-0, +5	±1	50
153	-0, +4	±1/2	40
203	-0, +3	±1/2	30
253	-0, +2	±1/2	30
323	-0, +2	±1/4	15

1. Measured from centers of backlash.
2. Zero backlash can be achieved at positions A and C by using optional stroke adjusters.

**Theoretical Output Torque (lb-in) at Specified Pressure**

Model	50 psi	100 psi	250 psi
103	19	39	98
153	59	118	294
203	141	282	705
253	215	430	1074
323	570	1141	2852

**Note:** When magnetic piston ring option “M” is ordered, all pistons will be so equipped.

PV Series  
PRN(A) Series  
PTR Series  
B671/F672 Series  
HP Series  
Rotary Actuators Products



**Antibacklash Actuator (7)**

An antibacklash actuator is used to obtain precision positioning at the end of rotation. The backlash normally associated with rack and pinion actuators is eliminated by this unique configuration.

**Operation:**

A double rack unit is modified for actuation on one end only. Alternately pressurizing C-1 or C-2 causes clockwise and counter-clockwise rotation, respectively. Backlash in the rack & pinion is eliminated as the pinion is tightly “trapped” between both racks at the end of stroke, preventing any further motion.

**Dimensional Data:**

Antibacklash actuators are similar in size and configuration to standard double rack units with one set of shorter cylinders. The table to the right shows dimensions for this shorter side. If cushions, stroke adjusters or port flow controls are ordered, they will be fitted to the powered rack side.

**Output Torque:**

Output torque of the antibacklash actuator is equivalent to the torque output of the same size single rack unit. The chart to the right gives selected torque valves for specified pressures.

**Ordering Information:**

**Theoretical Output Torque, lb-in, at Specified Pressure**

Model	50 psi	100 psi	250 psi
107	19	39	98
157	59	118	294
207	141	282	705
257	215	430	1074
327	570	1141	2852

Antibacklash actuators can be ordered by inserting a “7” into the “configuration” space in the model code. For example: **PTR157-180F-AR21-C** is a pneumatic antibacklash actuator with a theoretical output torque of 118 lb-in at 100 psi.

The optional stroke adjusters make the rotation variable between 120° and 180°. The preload key option on the shaft is also specified to eliminate any backlash in the key and coupling interface.

**Note:** Antibacklash can also be obtained on double rack actuators by implementing stroke adjusters at end of stroke. This will enable you to maintain double rack output torque.

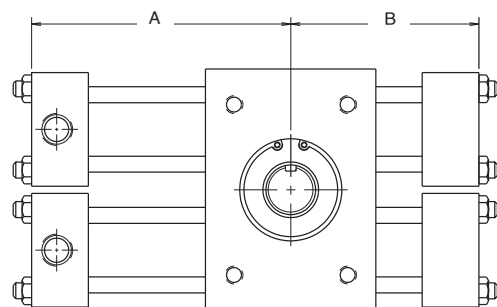
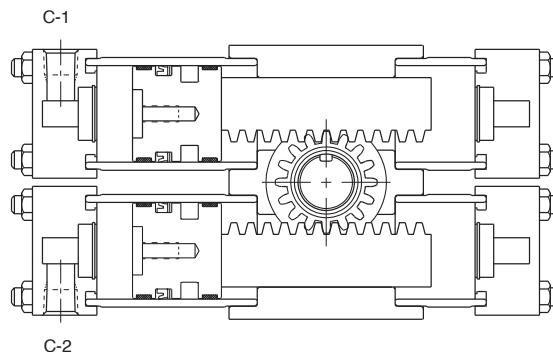

**Dimensions**

Model	Rotation	A	B
107	90°	3-3/4	2-3/4
	180°	4-1/8	3-3/4
	360°	5-3/4	5
157	90°	4-9/16	3-5/16
	180°	5-5/8	4-9/16
	360°	7-11/16	6-5/8
207	90°	5-5/8	4-1/8
	180°	7-1/16	5-5/8
	360°	9-7/8	8-1/2
257	90°	6-5/16	4-3/8
	180°	7-3/4	6-5/16
	360°	10-5/16	8-13/16
327	90°	8-5/16	5-13/16
	180°	10-9/16	8-5/16
	360°	14-11/16	12-7/16

**Self-Contained Tandem Air / Oil Operation (6)**

The Air-Oil Tandem actuator allows precise speed and motion control using standard pneumatic controls. This is possible through the use of a completely sealed oil system which effectively meters and controls actuator movement with no slipping, jerking, or bouncing.

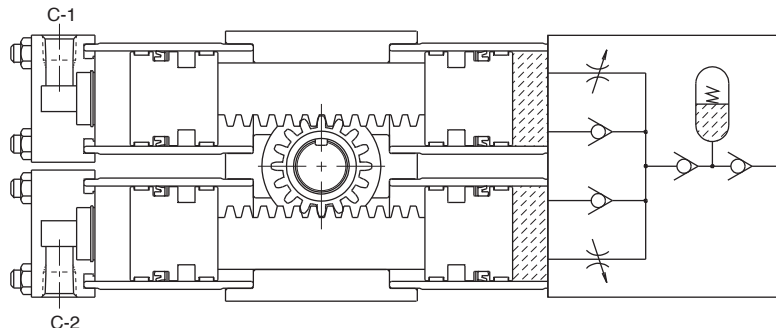

**Operation:**

A standard double rack unit is equipped with a built in hydraulic reservoir and flow controls. Air pressure is alternately applied to ports C-2 and C-1 to cause rotation in either direction. As oil is displaced from the opposite end of the drive rack it is metered precisely by the needle valve. A check valve allows free flow in the opposite direction so that independent speeds for rotation can be set.

The reservoir is directly attached to the actuator, eliminating plumbing and leakage paths. It is spring loaded to compensate for oil volume changes due to temperature variations and has built in fill port.

**Dimensional Data:**

Air / Oil Actuators are identical in size and configuration to standard double rack units, with the addition of the integral reservoir as shown.

**Output Torque:**

Theoretical output torques are shown in the table below. For design and sizing purposes an actuator should be selected with 20%-50% reserve capacity.

For maximum speed of the Air/Oil actuators please consult the factory or local representative.

**Ordering Information:**

Air / Oil Tandem actuators can be ordered by placing a “6” into the “configuration” space in the model code. All Air / Oil Tandem actuators include as standard port flow controls and Quad-ring piston seals (oil side only), thus it is not necessary to include a “P” and/or “Q” in the model code. Other options, such as cushions, stroke adjusters and magnetic piston ring are also available. For example: **PTR206-180F-AB21-C** is a standard Air/Oil actuator, with a theoretical output torque of 282 lb-in at 100 psi. Rotation of the unit is 180°, with optional cushions and stroke adjusters.

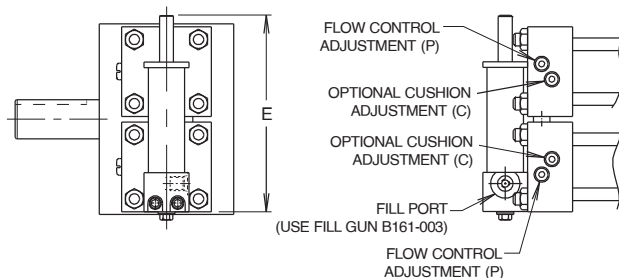
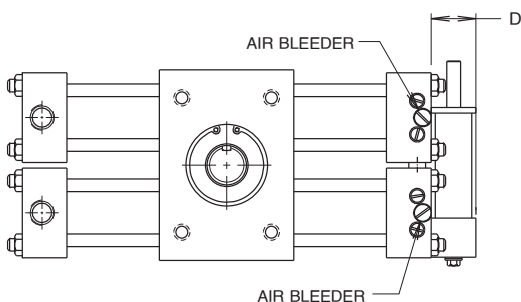

**Dimensions**

Model	D	E
106	1.00	3.63
156	1.00	4.38
206	1.25	4.91
256	1.25	4.91
326	1.25	6.29

**Note:** When magnetic piston ring option “M” is ordered, only the pneumatic pistons will be so equipped.

**Theoretical Output Torque, lb-in, at Specified Pressure**

Model	50 psi	100 psi	250 psi
106	19	39	98
156	59	118	294
206	141	282	705
256	215	430	1074
326	570	1141	2852

PV Series  
PRN(A) Series  
PTR Series  
B671/F672 Series  
HP Series  
Rotary Actuators Products



For inventory, lead times, and kit lookup, visit [www.pdnplu.com](http://www.pdnplu.com)

Options

PV Series  
PRN(A) Series  
PTR Series  
B671/F672 Series  
HP Series  
Rotary Actuators Products  
H

**External Air / Oil Operation (Q)**

The External Air/Oil actuator allows for connection to a separate air over oil control system. It can also be used for low pressure (less than 150 psi) non-shock hydraulic systems.

**Operation:**

A standard pneumatic rotary actuator is equipped with special piston seals for all pistons to ensure low breakaway pressure and no leakage. This allows smooth, jerk-free operation, even at very low pressures.

**Output Torque:**

Theoretical output torques are identical to the ones given at the beginning of the PTR section. For design and sizing purposes, an actuator should be selected with 20% - 50% reserve capacity.

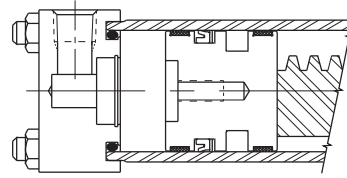

**NOTE:** When cushions are specified, the actuator will be equipped with bronze cushion bushings in place of the standard nitrile cushion bushings.

**Port Flow Controls (P)**

Built in meter-out flow controls provide precise adjustment of actuator speed and eliminate the cost and space of externally plumbed components. A separate ball check is used to provide free flow in the opposite direction. Flow controls may be ordered in conjunction with cushions, bumpers, or stroke adjusters.

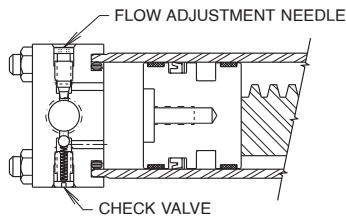

**Standard Adjustment Needle Locations**

Port Position	Needle Position
1	2
2	3
3	2
4*	3

\* Single rack only

**Note:** When both cushions and port flow controls are specified they will be stamped "C" and "P" respectively.

**Shaft Seal Covers (S)**

Shaft seal covers are designed to prolong bearing life by isolating them from external contamination and pressure. They are designed for use with standard male shafts only (not hollow shafts).

**Specifications**

- Max. Pressure Differential: 500 psi
- Material: Anodized Aluminum
- Shaft Seal: Double Lip Wiper
- Body Seal: O-Ring

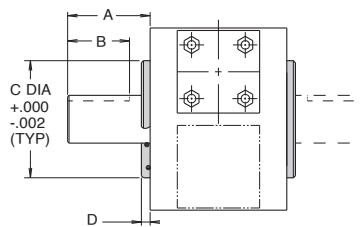

Model	A	B	C	D
10	7/8	1/2	1.875	0.25
15	1-7/8	1-5/16	3.000	0.38
20	1-7/8	1-5/16	3.250	0.38
25	2-1/4	1-5/8	3.625	0.38
32	3-1/2	2-7/8	4.480	0.38

**Fluorocarbon Seals (V)**

Fluorocarbon seals are recommended for high temperature applications up to 250°F. Standard abrasion resistant nitrile seals should be used for general purpose applications with temperatures of 0 to 180°F.

Option	Temperature Range (°F)
Shock Absorbers	32 - 150
Bumpers	0 - 200
Piston Magnets	0 - 165
Proximity Sensors	-4 - 150
Reed/Hall Effect Sensors	14 - 140



For inventory, lead times, and kit lookup, visit [www.pdnplu.com](http://www.pdnplu.com)

**Magnetic Piston (M)**

This option prepares the actuator for use with reed and Hall effect sensors. The “M” option should be specified to provide a magnet on the cylinder piston. Order sensors separately from the Electronic Sensors section.

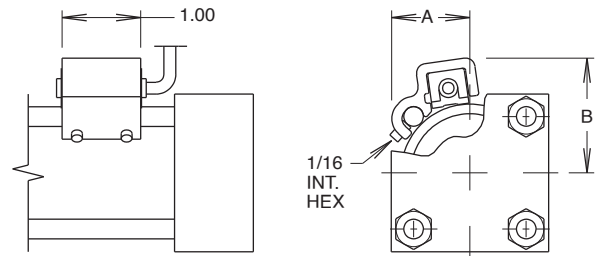
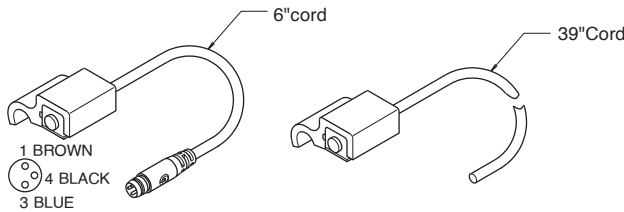

Model	A	B
10	0.84	1.22
15	0.99	1.46
20	1.27	1.68
25	1.45	1.89
32	1.71	2.20

**Proximity Sensors**

**(Namco Cylinders or Balluff Cylinder Indicator Sensor)**

The inductive type proximity sensor provides end of rotation indication. The non-contact probe senses the presence of the ferrous cushion spear and has no springs, plungers, cams or dynamic seals that can wear out or go out of adjustment. The sensor is solid state and meets NEMA 1, 12 & 13 specifications. For ease of wiring the connector housing is rotatable through 360°. To rotate, lift the cover latch, position and release.

The sensor make/break activation point may occur at 0.125" to ±0.125" from the end of stroke. Depending on the actuator size, this distance may cause activation at 2° to 15° from end of stroke.

The standard proximity sensor controls 50-230 VAC/DC loads from 5 to 500 mA. The low 1.7 mA off-state leakage current can allow use for direct PLC input. The standard short circuit protection (SCP) protects the sensor from a short in the load or line upon sensing such a condition (5 amp or greater current) by assuming a non-conductive mode. The fault condition must be corrected and the power removed to reset the sensor preventing automatic restarts.

The low voltage DC sensor is also available for use with 10-30 VDC. The sensor is in a non-rotatable housing, but does incorporate the short circuit protection.

Both sensors are equipped with two LEDs, “Ready” and “Target”. The “Ready” LED is lit when power is applied and the cushion spear is not present. The “Target” LED will light and the “Ready” LED will go out when the sensor is closed, indicating the presence of the cushion spear. Both LEDs flashing indicates a short circuit condition.

**NOTES:**

1. Available with or without cushions.
2. Not available with stroke adjusters.
3. Pressure rating: 3000 psi
4. Operating temperature: -4°F to 158°F
5. Specify sensor type, orientation and voltage when ordering.
6. The low voltage DC sensor is available in non-rotatable style only; consult factory for further information.

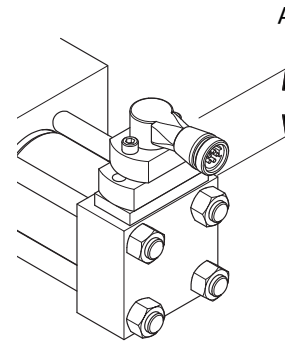

**EPS-6**

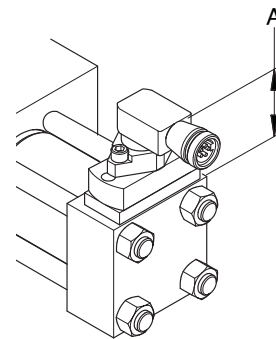

**EPS-7**

Model	A
15	2.17
20	2.75
25	2.48
32	2.25

Order proximity sensors separately. See Electronic Sensors section for specifications and ordering information.



Features

B671 / F672 Series

PV	Series
PRN(A)	Series
PTR	Series
B671/F672	Series
HP	Series
Rotary Actuators	Products
<b>H</b>	

**BEARINGS**  
High quality bronze bearings reduce friction and Break-away pressure while providing substantial pinion support.

**KEYWAY**  
At 12:00 position of mid-stroke of actuator.

**PISTON SEALS**  
Low friction lipseals are fully dynamic and self-compensating for no-leak service and long life at all operating pressures.

**END CAPS**  
Precision machined from cold rolled steel to exacting NFPA specifications, then black oxide coated for greater reliability and durability.

**PORTS**  
Full area ports provide unrestricted flow for maximum operating speeds.

**OPTIONAL CUSHIONS**  
Provide maximum performance and reduced shock in all applications. The floating polyurethane cushion seal provides maximum sealing effectiveness as the spear enters the cushion, yet allows fast "out-stroke" action by functioning as a springless check valve. Full adjustment of the cushion is obtained by the flush mounted adjustment needle.

**RACK & PINION**  
Chromium alloy steel with flame hardening ensures maximum shock resistance and strength of the rack & pinion.

**HOUSING**  
A high strength aluminum housing is hard anodized for superior wear and corrosion resistance.

**CYLINDER**  
Precision finished aluminum alloy tubing is hard anodized for maximum wear resistance and long seal life.

**SIDE TAPPED**  
Mounting Holes  
Front and rear heads

**FEMALE SHAFT** Designed for direct, on-shaft installation, eliminating the need or couplings and other connections.

**TIE RODS**  
High tensile steel has precision rolled threads and black oxide coating for greater strength and fatigue resistance.

**PISTONS**  
Are one piece steel for high strength and piloted to the rack assembly to ensure concentricity. A nonmetallic wear strip is employed to provide a non-scoring bearing surface. This high quality assembly eliminates friction, wear and galling while providing smooth operation.

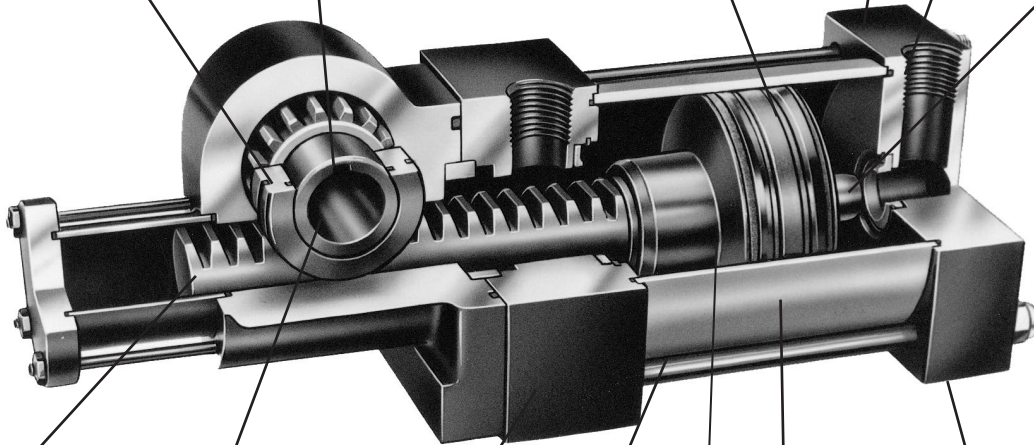



## Features

- Standard Rotations: 90°, 180°, 360°
- Output Torque @ 100 psi: 100 lb-in to 2500 lb-in
- Maximum Break-away Pressure: 10 psi
- Mounting Orientation: Unrestricted
- Leakage: External: 0 cfm  
Internal: 0 cfm
- Theoretical Timing: Keyway located at 12:00 position at mid-stroke position of actuator

### B671 Series

The B671 Pneumatic Rotary Actuator is designed to provide force in a reciprocating, rotational motion. It is ideal for any application requiring constant torque through a rotational distance: rotating or lifting heavy objects, positioning or bending operations.

### F672 Series

The F672 utilizes the same high quality construction found on the B671 Series with the addition of a coupling arrangement for a Hydro-Check. An F672 / Hydro-Check assembly will provide controlled feed rates and excellent rotational control with pneumatic power through adjustable hydraulic resistance.

### B671 / F672 Series

Pneumatic Rotary Actuator can be powered by shop air or inert gas. The actuators are pre-lubricated at assembly with NLG1 grade 2 grease with outstanding oxidation stability and corrosion resistant additives. This pre-lubrication is intended for use in pneumatic systems where airline lubrication is not used. However, to assure maximum service life of the cylinder, the air supply should be properly filtered and moisture free.

The pneumatic rotary actuator can be controlled by any conventional 4-way valve - hand, foot, mechanically or electrically controlled. All four sizes of rotary actuators are designed for direct on-shaft installation - no flexible couplings, cam and roller or chain and sprocket combinations are required.

### B671 / F672 Series Cushion Option

The standard cushions operate at the end of rotation to decelerate the actuator. A floating polyurethane cushion seal provides maximum sealing effectiveness going into the cushion. This durable material ensures millions of trouble free cycles with no wear. The cushion seal also acts as a check valve, allowing full air flow around the seal during outstroke, providing excellent break-away. Cushions, when so ordered, are installed both directions. They are available on both the B671 and F672 Series.

## Quick Reference Data

Model	Cylinder Bore (in)	Actual Output Torque (lb-in) Versus Specified Pressure (PSI)				Displacement Per Degree Rotation (in <sup>3</sup> /°)	Maximum Angular Backlash (minutes)	Maximum Rotational Tolerance (°)
		50	75	100	125			
1	1-1/2	50	75	100	125	0.021	40	-0, +5
2	3-1/4	250	375	500	625	0.116	40	-0, +4
3	4	500	750	1000	1250	0.219	40	-0, +3
4	5	1250	1875	2500	3125	0.514	30	-0, +2

## Rotary Actuators B671 / F672 Series

### Operating information

Operating pressure (max):	140 PSIG (9.65 bar)
Temperature range:	0°F to 180°F (-17°C to 82°C)

### Hydro-Check Combination

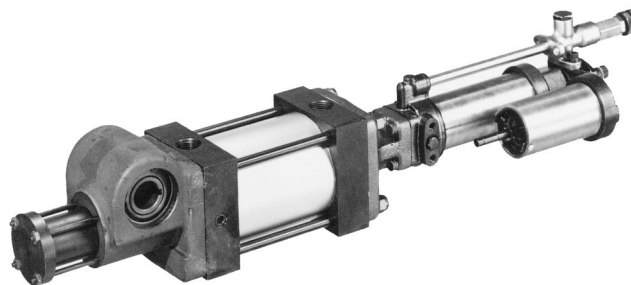

The Rotary Actuator/Hydro-Check combination consists of the F672 Series Actuator axially linked to an F172-2 or F172-3 Series Hydro-Check. The Hydro-Check is a precision built adjustable hydraulic resistance unit designed to provide controlled feed rates. When coupled to an actuator, excellent rotational control is attained.

The Rotary Actuator / Hydro-Check combination provides consistent torque with adjustable hydraulic resistance for a smooth controlled rotational feed rate. Axial coupling of these units eliminates eccentric loading of component parts.

These actuators are available in three torque ranges to comply with varying load requirements. The Hydro-Check is capable of checking axial loads to 3,000 lbs. and is available with many controlling options (see Ordering Information). For information on Hydro-Checks not shown in this catalog, consult factory.

PV Series

PRN(A) Series

PTR Series

B671/F672 Series

HP Series

Rotary Actuators Products

H

**B671 / F672 Series Ordering Information**

<b>B671</b>	<b>2</b>	<b>20</b>	<b>D</b>																		
<table border="1" style="width: 100%; border-collapse: collapse;"> <tr><th colspan="2">Series</th></tr> <tr><td><b>B671</b></td><td>Pneumatic Rotary Actuator</td></tr> <tr><td><b>F672</b></td><td>Pneumatic Rotary Actuator with Hydro-Check Mounting Interface</td></tr> </table>		Series		<b>B671</b>	Pneumatic Rotary Actuator	<b>F672</b>	Pneumatic Rotary Actuator with Hydro-Check Mounting Interface	<table border="1" style="width: 100%; border-collapse: collapse;"> <tr><th colspan="2">Cushions</th></tr> <tr><td><b>5</b></td><td>No Cushions</td></tr> <tr><td><b>8</b></td><td>Cushions Both Rotations</td></tr> </table>		Cushions		<b>5</b>	No Cushions	<b>8</b>	Cushions Both Rotations						
Series																					
<b>B671</b>	Pneumatic Rotary Actuator																				
<b>F672</b>	Pneumatic Rotary Actuator with Hydro-Check Mounting Interface																				
Cushions																					
<b>5</b>	No Cushions																				
<b>8</b>	Cushions Both Rotations																				
<table border="1" style="width: 100%; border-collapse: collapse;"> <tr><th colspan="2">Torque Output in in-lb @ 100 PSI</th></tr> <tr><td><b>1</b></td><td>100 *</td></tr> <tr><td><b>2</b></td><td>500</td></tr> <tr><td><b>3</b></td><td>1000</td></tr> <tr><td><b>4</b></td><td>2500</td></tr> </table>		Torque Output in in-lb @ 100 PSI		<b>1</b>	100 *	<b>2</b>	500	<b>3</b>	1000	<b>4</b>	2500	<table border="1" style="width: 100%; border-collapse: collapse;"> <tr><th colspan="2">Degrees Rotation</th></tr> <tr><td><b>10</b></td><td>90°</td></tr> <tr><td><b>20</b></td><td>180°</td></tr> <tr><td><b>30</b></td><td>360°</td></tr> </table>		Degrees Rotation		<b>10</b>	90°	<b>20</b>	180°	<b>30</b>	360°
Torque Output in in-lb @ 100 PSI																					
<b>1</b>	100 *																				
<b>2</b>	500																				
<b>3</b>	1000																				
<b>4</b>	2500																				
Degrees Rotation																					
<b>10</b>	90°																				
<b>20</b>	180°																				
<b>30</b>	360°																				
* 100 lb-in size unit not available for F672 series																					

**F172 Inline Hydro-Check Ordering Information**  
For Use with F672 Rotary Actuator

<b>F172</b>	-	<b>20</b>	<b>10</b>	<b>3</b>																																				
Hydro-Check Inline Assembly				Stroke (see stroke table)																																				
		Checking Action																																						
		<table border="1" style="width: 100%; border-collapse: collapse;"><tr><td><b>20</b></td><td>Single Acting</td></tr><tr><td><b>30</b></td><td>Double Acting</td></tr></table>	<b>20</b>	Single Acting	<b>30</b>	Double Acting		<table border="1" style="width: 100%; border-collapse: collapse;"><tr><td><b>1</b></td><td>2 in.</td></tr><tr><td><b>2</b></td><td>4 in.</td></tr><tr><td><b>3</b></td><td>6 in.</td></tr><tr><td><b>4</b></td><td>9 in.</td></tr><tr><td><b>5</b></td><td>12 in.</td></tr></table>	<b>1</b>	2 in.	<b>2</b>	4 in.	<b>3</b>	6 in.	<b>4</b>	9 in.	<b>5</b>	12 in.																						
<b>20</b>	Single Acting																																							
<b>30</b>	Double Acting																																							
<b>1</b>	2 in.																																							
<b>2</b>	4 in.																																							
<b>3</b>	6 in.																																							
<b>4</b>	9 in.																																							
<b>5</b>	12 in.																																							
		Hydro-Check Valve Options Single Acting		Hydro-Check Valve Options Double Acting																																				
		<table border="1" style="width: 100%; border-collapse: collapse;"><tr><td><b>01</b></td><td>Standard</td></tr><tr><td><b>02</b></td><td>Standard Reverse Acting</td></tr><tr><td><b>11</b></td><td>Stop &amp; Skip Forward Acting</td></tr><tr><td><b>12</b></td><td>Stop &amp; Skip Reverse Acting</td></tr><tr><td><b>13</b></td><td>Precision</td></tr><tr><td><b>14</b></td><td>Precision Reverse Acting</td></tr></table>	<b>01</b>	Standard	<b>02</b>	Standard Reverse Acting	<b>11</b>	Stop & Skip Forward Acting	<b>12</b>	Stop & Skip Reverse Acting	<b>13</b>	Precision	<b>14</b>	Precision Reverse Acting		<table border="1" style="width: 100%; border-collapse: collapse;"><tr><td><b>01</b></td><td>Standard</td></tr><tr><td><b>36</b></td><td>Stop &amp; Skip</td></tr><tr><td><b>37</b></td><td>Precision</td></tr><tr><td><b>52</b></td><td>Precision with Stop &amp; Skip</td></tr></table>	<b>01</b>	Standard	<b>36</b>	Stop & Skip	<b>37</b>	Precision	<b>52</b>	Precision with Stop & Skip																
<b>01</b>	Standard																																							
<b>02</b>	Standard Reverse Acting																																							
<b>11</b>	Stop & Skip Forward Acting																																							
<b>12</b>	Stop & Skip Reverse Acting																																							
<b>13</b>	Precision																																							
<b>14</b>	Precision Reverse Acting																																							
<b>01</b>	Standard																																							
<b>36</b>	Stop & Skip																																							
<b>37</b>	Precision																																							
<b>52</b>	Precision with Stop & Skip																																							
				Hydro-Check Stroke Table																																				
				<table border="1" style="width: 100%; border-collapse: collapse;"><thead><tr><th>Model</th><th>Nominal Torque Output (lb-in)</th><th>Rotation Range (°)</th><th>Hydro-Check Stroke Required (in)</th></tr></thead><tbody><tr><td rowspan="3">2</td><td rowspan="3">500</td><td>30-140</td><td>2</td></tr><tr><td>141-284</td><td>4</td></tr><tr><td>285-360</td><td>6</td></tr><tr><td rowspan="4">3</td><td rowspan="4">1000</td><td>30-112</td><td>2</td></tr><tr><td>113-227</td><td>4</td></tr><tr><td>228-341</td><td>6</td></tr><tr><td>342-360</td><td>9</td></tr><tr><td rowspan="4">4</td><td rowspan="4">2500</td><td>30-74</td><td>2</td></tr><tr><td>75-151</td><td>4</td></tr><tr><td>152-227</td><td>6</td></tr><tr><td>228-342</td><td>9</td></tr><tr><td></td><td></td><td>343-360</td><td>12</td></tr></tbody></table>	Model	Nominal Torque Output (lb-in)	Rotation Range (°)	Hydro-Check Stroke Required (in)	2	500	30-140	2	141-284	4	285-360	6	3	1000	30-112	2	113-227	4	228-341	6	342-360	9	4	2500	30-74	2	75-151	4	152-227	6	228-342	9			343-360	12
Model	Nominal Torque Output (lb-in)	Rotation Range (°)	Hydro-Check Stroke Required (in)																																					
2	500	30-140	2																																					
		141-284	4																																					
		285-360	6																																					
3	1000	30-112	2																																					
		113-227	4																																					
		228-341	6																																					
		342-360	9																																					
4	2500	30-74	2																																					
		75-151	4																																					
		152-227	6																																					
		228-342	9																																					
		343-360	12																																					

- Notes:**
- Hydro-Check must be ordered separately.
  - When both Actuator and Hydro-Check are ordered from Actuator Division, they will be assembled together.
  - Specify voltage with stop and skip function - 12, 115, 220 or 440 VAC.
  - For availability of other Hydro-Check options not listed here, please consult factory.

**Service Kits – B671 / F672 \***

Actuator Size (cushioned or non-cushioned)	Seal Kit Number
100 lb-in	<b>B732904</b>
500 lb-in	<b>B732905</b>
1,000 lb-in	<b>B732906</b>
2,500 lb-in	<b>B732907</b>

\* Does not include Hydro-Check seal kit.



For inventory, lead times, and kit lookup, visit [www.pdnplu.com](http://www.pdnplu.com)

**B671 Series**

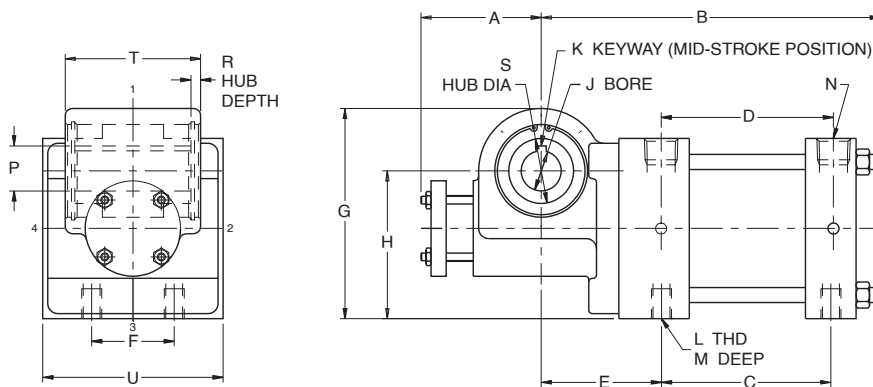

Model	Rotation	A	B	C	D	E	F	G	H	J	K	L	M	N	P	R	S	T	U	
1	90°	2.16	6.45	3.36	3.42															
	180°	3.35	7.53	4.44	4.50	2.19	0.62	2.94	1.92	0.500	0.12 x	1/4-20	0.38	3/8	0.560	0.16	1.00	1.69	2.00	
	360°	5.35	9.68	6.60	6.66					0.502	1.31				0.570					
2	90°	2.50	7.95	3.92	3.99															
	180°	3.75	9.21	5.17	5.25	2.81	1.50	4.44	3.12	0.875	0.19 x	1/2-13	0.75	1/2	0.964	0.22	1.25	3.12	3.75	
	360°	6.25	11.72	7.69	7.76					0.877	2.62				0.974					
3	90°	3.00	8.46	4.23	4.30															
	180°	4.56	10.03	5.80	5.87	3.00	2.06	5.25	3.69	1.000	0.25 x	1/2-13	0.75	1/2	1.117	0.24	1.62	3.38	4.50	
	360°	7.96	13.17	8.94	9.01					1.002	2.88				1.127					
4	90°	3.56	10.51	5.28	5.35															
	180°	5.75	12.87	7.63	7.71	3.88	2.69	6.88	4.75	1.500	0.38 x	5/8-11	0.94	1/2	1.668	0.31	2.50	4.12	5.50	
	360°	10.75	17.58	12.34	12.42					1.502	3.50				1.678					

**F672 Series**

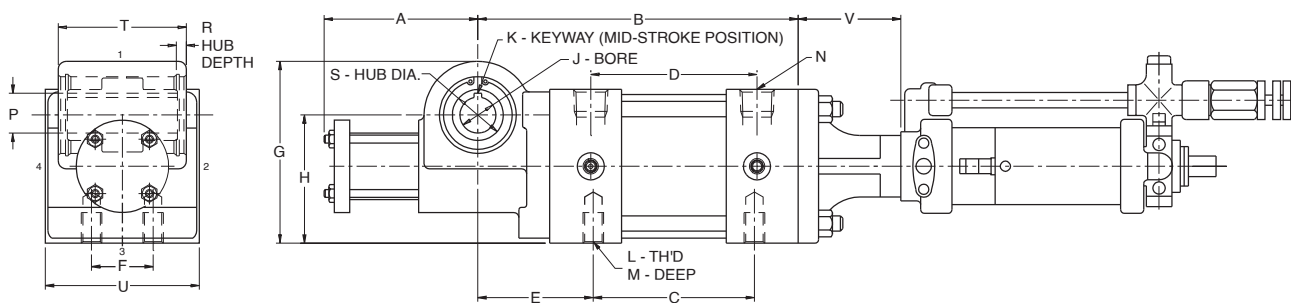

**F672 Actuator with Hydro-check**

Model	Rotation	A	B	C	D	E	F	G	H	J	K	L	M	N	P	R	S	T	U	V
2	90°	2.50	7.80	3.92	4.05															
	180°	3.75	9.06	5.17	5.31	2.81	1.50	4.44	3.12	0.875	0.19 x	1/2-13	0.75	1/2	0.964	0.22	1.25	3.12	3.75	2.50
	360°	6.25	11.57	7.69	7.82						0.877	2.62			0.974					
3	90°	3.00	8.30	4.23	4.36															
	180°	4.56	9.87	5.80	5.93	3.00	2.06	5.25	3.69	1.000	0.25 x	1/2-13	0.75	1/2	1.117	0.24	1.62	3.38	4.50	2.50
	360°	7.96	13.01	8.94	9.07					1.002	2.88				1.127					
4	90°	3.56	10.22	5.28	5.41															
	180°	5.75	12.58	7.63	7.77	3.88	2.69	6.88	4.75	1.500	0.38 x	5/8-11	0.94	1/2	1.668	0.31	2.50	4.12	5.50	2.50
	360°	10.75	17.29	12.34	12.48					1.502	3.50				1.678					



For inventory, lead times, and kit lookup, visit [www.pdnplu.com](http://www.pdnplu.com)

PV Series  
 PRN(A) Series  
 PTR Series  
 B671/F672 Series  
 HP Series  
 Rotary Actuators Products  
**H**

Features

HP Series

PV Series
PRN(A) Series
PTR Series
B671/F672 Series
HP Series
Rotary Actuators Products
<b>H</b>

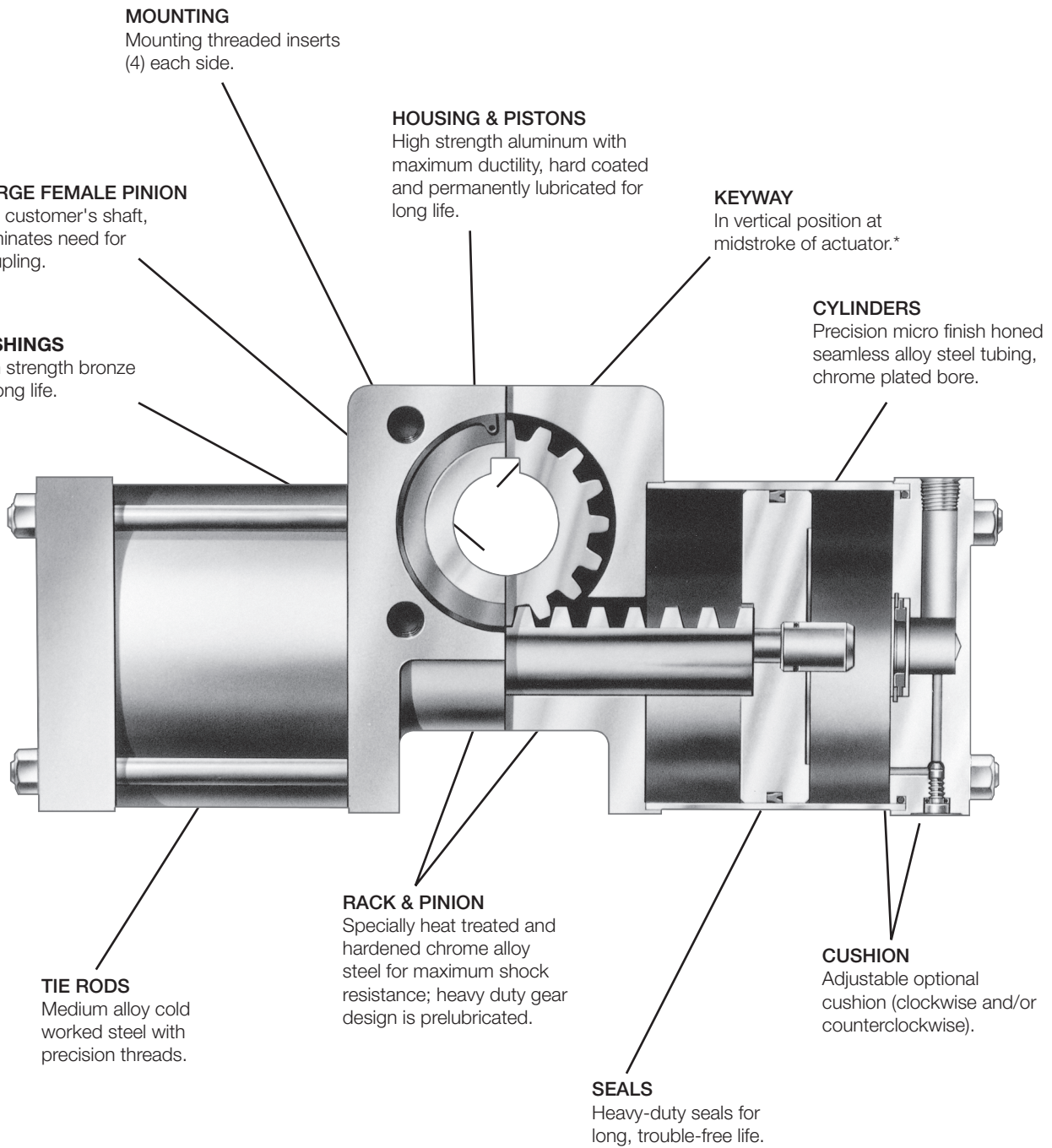

## Features

- Rack and pinion rotary actuator
- 2 large bore models
- 3 standard rotations: 90°, 180°, 360°
- Standard output torque at 100 PSIG: 4,500 and 10,000 lb-in
- Large female pinion
- Available with adjustable cushions and stroke adjusters

## Rotary Actuators HP Series

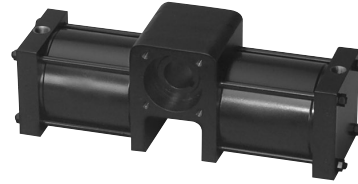

### Operating information

Operating pressure:	100 PSIG (6.9 bar)
Temperature range:	
Nitrile seals	0°F to 180°F (-18° to 82°C)
Fluorocarbon seals	0°F to 250°F (-18° to 121°C)
Filtration requirements:	40 micron, dry filtered air

### Ordering information

**HP 10 - 090 3 C - A A 2 V -**

Model	
4.5	4,500 lb-in Output Torque
10	10,000 lb-in output torque

Rotation <sup>1</sup>	
090	90°
180	180°
360	360°

Specify other rotations.

Cushions	
Omit	None
1	CW Rotation <sup>2</sup>
2	CCW Rotation <sup>2</sup>
3	Both Rotation
9	Special

Stroke Adjusters	
Omit	None
A	0-5° CW Rotation <sup>2</sup>
B	0-5° CCW Rotation <sup>2</sup>
C	0-5° both Rotation
D	0-30° CW Rotation <sup>2,3</sup>
E	0-30° CCW Rotation <sup>2,3</sup>
F	0-30° Both Rotation <sup>3</sup>
X	Special

Special Options	
Omit	Standard
Two digit code assigned by factory when any "X" or "9" appears in the model number or when special options or features are required.	

Seals	
Omit	Nitrile (standard)
V	Fluorocarbon
X	Special

Port Type	
2	NPTF (standard)
9	Special

Shaft Configuration	
A	Female Keyed Shaft
B	Male Keyed Shaft
D	Female SAE 10B Spline
E	Male SAE 10B Spline
X	Special

Mounting Style	
A	Face (standard)
X	Special

**Notes:**

- <sup>1</sup> To obtain equal rotation both sides of midstroke (theoretical 12:00), order 5° longer rotation than standard with stroke adjusters.
- <sup>2</sup> Viewed from shaft end.
- <sup>3</sup> Cannot combine with cushions.

**Sensors**  
See section L for sensors.

PV Series

PRN(A) Series

PTR Series

B671/F672 Series

HP Series

Rotary Actuators Products

H



**Quick reference data**

Model	Rotation* (Degrees)	Displacement (Cubic inches)	Weight (lb)	Bore Size	Actual Torque Output at 100 psi (lb-in)	Maximum Rotational Tolerance (degrees)	Maximum Angular Backlash (minutes)
4.5	90°	79.93	63	6"	4,500	-0, +2	15
	180°	159.86	75				
	360°	319.72	95				
10	90°	177.64	125	8"	10,000	-0, +2	15
	180°	355.28	147				
	360°	710.56	190				

\* To obtain equal rotation both sides of midstroke (theoretical 12:00), order 5° longer rotation than standard with stroke adjusters.

**Bearing load capacities and kinetic energy ratings**

Model	Radial Load (lb) Per Bearing		Thrust Load (lb)		Distance Between Bearings (in.)	Maximum Kinetic Energy Rating for Models Based on Configuration (in-lb)		
	Dynamic	Static	Dynamic	Static		Standard	Stroke Adjusters	Cushion
4.5	2,000	3,000	300	450	2.77	45	45	650
10	2,000	3,000	500	750	3.63	100	100	1,450

**Seal kit ordering information**

- Standard units are equipped with Nitrile seals.
- Optional seal compounds are available.
- Seal kit part numbers as shown:

<b>PSK</b> Parker Seal Kit	—	<b>HP4.5</b> Base Model	<b>V</b>	
			Omit	Standard
			V	Fluorocarbon
			N	Non-Lube

PV Series  
 PRN(A) Series  
 PTR Series  
 B671/F672 Series  
 HP Series  
 Rotary Actuators Products



**Standard face mount (A) and female keyed shaft (A) shown**

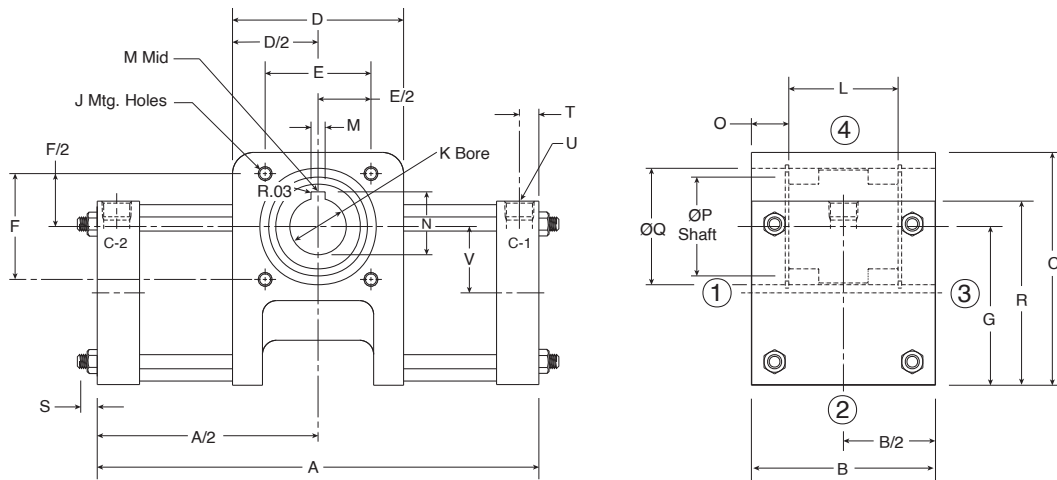

**Notes:** Pressure on C-1 port gives clockwise rotation.  
 Pressure on C-2 port gives counterclockwise rotation.

Numbers above represent possible mounting and port positions.

Model	Rotation (Degrees)	A	B	C	D	E	F	G	J	K
4.5	90°	15-5/8								
	180°	22-1/4	6.525	8-1/4	6.063	3.750	3.750	5.615	7/16-14 x 21/32 DP	2.000 2.003
	360°	33								
10	90°	18								
	180°	26-3/4	8.525	10-1/2	7.813	5.000	5.000	7.265	5/8-11 x 15/16 DP	2.250 2.253
	360°	39-5/8								

Model	L	M	N	O	P	Q	R	S	T	U	V
4.5	3-7/8	0.500	2.223	1-5/16	3-1/2	4-1/8	6-1/2	5/8	0.69	3/4 NPTF	2.35
		0.502	2.233								
10	5	0.625	2.525	1-3/4	4-1/2	5-1/4	8-1/2	3/4	0.69	3/4 NPTF	3.00
		0.628	2.535								

**Stroke Adjusters (A - F)**

5° stroke adjust option with cushion option

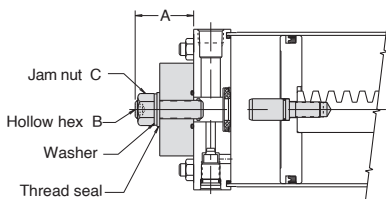

5° or 30° stroke adjust option without cushion option

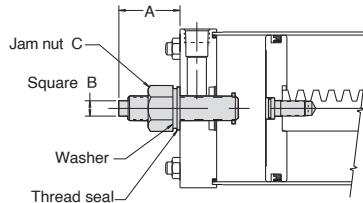

**Cushioned End Cap**

Model	(1) Turn Adjust	A			Non-Cushioned End Cap				
		A	B	C	(1) Turn Adjust	A	B	C	
4.5	2.5°	2.50	5/8	1.00-14	2.0°	2.00	2.81	3/8	3/4-16
	2.0°	2.50	15/16	1.50-12	1.5°	2.56	3.50	15/16	1-1/2-12

**Male Shaft (B)**

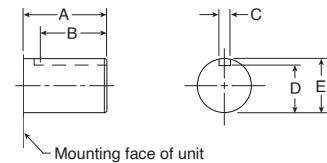

Model	A	B
4.5	2.61	2.38
10	4.38	3.38

Model	C	D	E
4.5	0.561	1.928	2.249
	0.562	1.933	2.250
10	0.625	1.888	2.249
	0.627	1.893	2.250



For inventory, lead times, and kit lookup, visit [www.pdnplu.com](http://www.pdnplu.com)

H45

**Parker Hannifin Corporation**  
 Pneumatic Division  
 Wadsworth, Ohio  
[www.parker.com/pneumatics](http://www.parker.com/pneumatics)

PV Series  
 PRN(A) Series  
 PTR Series  
 B671/F672 Series  
 HP Series  
 Rotary Actuators Products





**Options**

PV Series  
 PRN(A) Series  
 PTR Series  
 B671/F672 Series  
 HP Series  
 Rotary Actuators Products

**Cushions (1, 2, 3)**

The standard cushions operate over the last 20° of rotation in either direction. A floating bushing ensures no binding of cushion spear. All cushions are fully adjustable and are located on the side opposite the port. For other cushion locations specify "9" and describe.

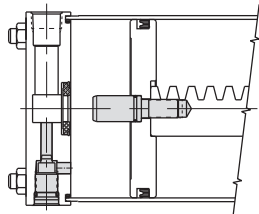

**Proximity Sensors**

**(Namco Cylinders or Balluff Cylinder Indicator Sensor)**

The inductive type proximity sensor provides end of rotation indication. The non-contact probe senses the presence of the ferrous cushion spear and has no springs, plungers, cams or dynamic seals that can wear out or go out of adjustment. The sensor is solid state and meets NEMA 1, 12 & 13 specifications. For ease of wiring the connector housing is rotatable through 360°. To rotate, lift the cover latch, position and release.

The sensor make/break activation point may occur at 0.125" to ±0.125" from the end of stroke. Depending on the actuator size, this distance may cause activation at 2° to 15° from end of stroke.

The standard proximity sensor controls 50-230 VAC/DC loads from 5 to 500 mA. The low 1.7 mA off-state leakage current can allow use for direct PLC input. The standard short circuit protection (SCP) protects the sensor from a short in the load or line upon sensing such a condition (5 amp or greater current) by assuming a non-conductive mode. The fault condition must be corrected and the power removed to reset the sensor preventing automatic restarts.

The low voltage DC sensor is also available for use with 10-30 VDC. The sensor is in a non-rotatable housing, but does incorporate the short circuit protection.

Both sensors are equipped with two LEDs, "Ready" and "Target". The "Ready" LED is lit when power is applied and the cushion spear is not present. The "Target" LED will light and the "Ready" LED will go out when the sensor is closed, indicating the presence of the cushion spear. Both LEDs flashing indicates a short circuit condition.

**NOTES:**

1. Available with or without cushions.
2. Not available with stroke adjusters.
3. Pressure rating: 3000 psi
4. Operating temperature: -4°F to 158°F
5. Specify sensor type, orientation and voltage when ordering.
6. The low voltage DC sensor is available in non-rotatable style only; consult factory for further information.

**Rotary Actuators  
HP Series**

**Additional Shaft Options (D, E)**

Hollowed key shaft is standard. Additional shaft options available are available as a special. Consult factory for information.

- Male splined (E)
- Female splined (D)

**Fluorocarbon Seals (V)**

Standard abrasion resistant nitrile seals should be used for general purpose applications with temperatures of 0 to 180°F. Fluorocarbon seals are recommended for high temperature applications up to 250°F.

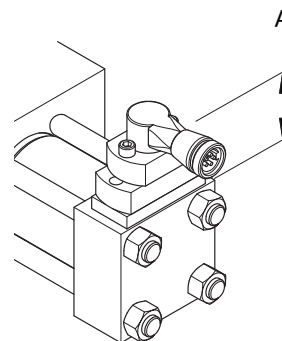

**EPS-6**

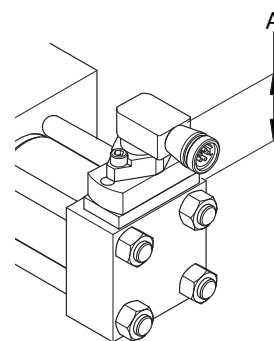

**EPS-7**

Model	A (max)
	EPS-6 & 7
4.5	1.59
10	2.28

Order proximity sensors separately. See Electronic Sensors section for specifications and ordering information.



For inventory, lead times, and kit lookup, visit [www.pdnplu.com](http://www.pdnplu.com)





## Stainless Steel Air Motors P1VAS Series

<b>Overview</b>	J2
Choosing the Correct Air Motor	J3
Principles of Air Motors	J4
Introduction	J5-J11

### P1VAS Air Motor Series

Features	J12
Technical Data	J13
Material and Technical Specification	J13
Choice of Vanes	J14
ATEX Classes	J14
Optimum Working Speed and Torque Range	J14
Permitted Shaft Loadings	J15

### Reversible Stainless Steel Air Motors - 120 to 1600 watts

120 watts	J16-J17
200 and 300 watts	J18-J19
600, 900 & 1600 watts	J20-J23

### Service Information

Lubrication and Service Life	J24
Service Kits	J25

### Ordering Information

	J26
--	-----

Overview

Features	Air motor	Hydraulic motor	Electric motor
Overload safe	***	***	*
Increased torque at higher loads	***	**	*
Easy to limit torque	***	***	*
Easy to vary speed	***	***	*
Easy to limit power	***	***	*
Reliability	***	***	***
Robustness	***	***	*
Installation cost	***	*	**
Ease of service	***	**	*
Safety in damp environments	***	***	*
Safety in explosive atmospheres	***	***	*
Safety risk with electrical installations	***	***	*
Risk of oil leak	***	*	***
Hydraulic system required	***	*	***
Weight	**	***	*
Power density	**	***	*
High torque for size	**	***	*
Noise level during operation	*	***	**
Total energy consumption	*	**	***
Service interval	*	**	***
Compressor capacity required	*	***	***
Purchase price	*	*	***

\* = good, \*\* = average, \*\*\* = excellent

P1VAS  
Stainless Steel

Air Motors



**Important**  
Before carrying out service activities, make sure the air motor is vented. Before disassembling the motor, disconnect the primary air hose to ensure that the air supply is interrupted.



**Note**  
All technical data in the catalog are typical values. The air quality is a major factor in the service life of the motor, see ISO 8573-1.



For inventory, lead times, and kit lookup, visit [www.pdnplu.com](http://www.pdnplu.com)

## P1VAS Series

### Choosing the correct air motor for your application

#### ① Which drive principle of the air motor is suitable for your application?

- Air vane motor are suitable for regular operating cycles, speed is very small e.g. 16 rpm
- Tooth gear air motor or turbines are more suitable for continuous operation, 24 hours non-stop, speed is in a upper range, up to 140,000 rpm
- Oil free operation is often an option for these three principles of air motors.

#### ② Which motor materials are suitable for your application?

- Will the air motor work in a normal production area
- Or in a paper industry
- Or in the food processing industry, in contact or not with food
- Or in underwater usage
- Or in the medical, pharmaceutical industries
- Or in potentially explosive areas
- Others, please describe your environment

#### ③ How do you calculate the motor power taking the application conditions into consideration?

1. Which rotational direction? Clockwise, anti-clockwise, reversible?
2. Air pressure working range? Which air class quality is available?
3. Which torque and which speed under load do you expect to obtain?
4. Calculate the basic power with the formula

$$P = M \times n / 9550 \text{ with } P \text{ power output in kW, } M \text{ nominal torque in Nm, } n \text{ nominal speed in rpm}$$

5. Check performance data of air motors in our catalogues. Note that all data is at 6 bar in the inlet of the air motor, max 3 meters for tubes and oil lubricated operations.
6. To adapt the difference of air pressure with your operation conditions, please check graphs in our catalogues and how to do it.
7. or you can adapt the need of air to fit your operation conditions by throttling the outlet flow in the air motor you will reduce speed without loss of torque.
8. Check if you need an oil free or not working operation. 1 to 2 drops of oil per cube meter are needed to optimize performance and life time of air motors. Oil free operation will decrease by 10 to 15% the performance of air motors.

#### ④ How do you integrate your air motor in your system?

- In which position is the air motor used?
- Do you need to use a brake?
- Do you want to use your own gear box and put it somewhere else in the machine?
- Do you need extra components like fittings, tubes, valves and FRLs?

#### ⑤ How do you ensure a long life and high performance of the air motor?

- Ensure you air quality is in accordance with our specifications, oil or oil free lubrication operations.
- Keep the recommended maintenance intervals

#### ⑥ How do you determine the purchasing and running costs after the air motor installation?

- Keep same level of your air quality.

**Principles of motor functioning**

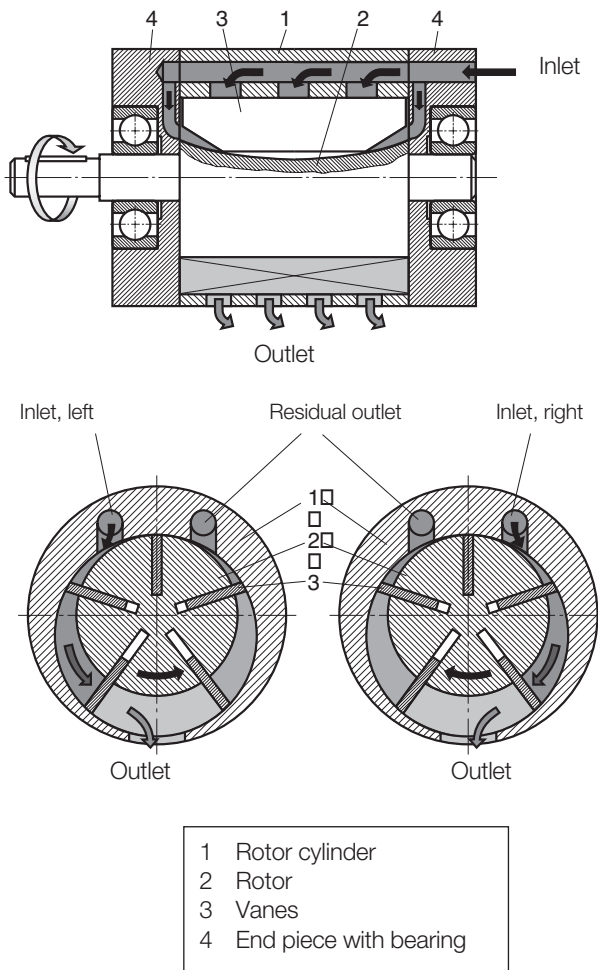

There are a number of air motor designs, Parker has chosen the vane rotor design due to its simplicity and reliable operation. Plus the small external dimensions of vane motors make them suitable for all applications.

The principle of the vane motor is that a rotor with a number of vanes is enclosed in a rotor cylinder. Compressed air is supplied through one connection and air escapes from the other.

For reliable starting, the springs press the vanes against the rotor cylinder and the air pressure always bears at right angles against a surface. This means that the resulting torque of the motor is due to the vane surfaces and the air pressure.

**Torque, power and air consumption Graphs**

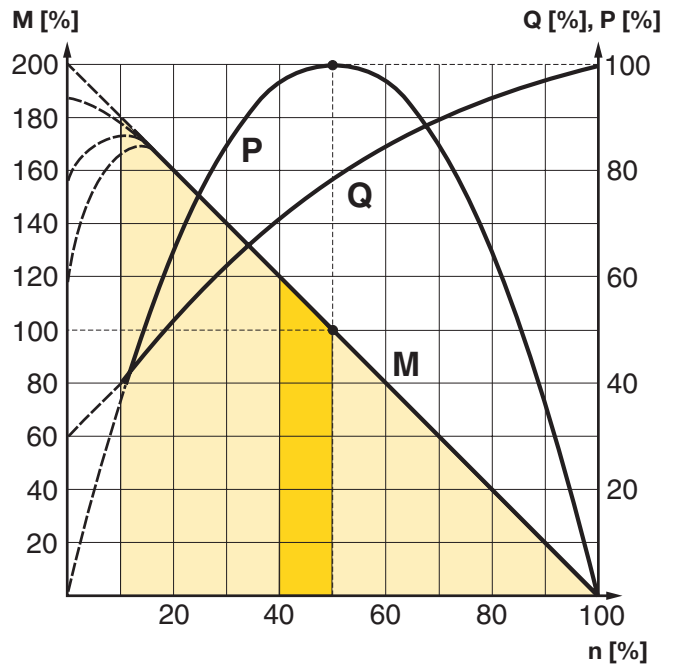

The curve is for 6 bar  
**P = power**      **Q = air consumption**  
**M = torque**      **n = speed**

**Possible working range of motor.**  
**Optimum working range of motor.**  
 Higher speeds = more vane wear  
 Lower speeds with high torque = more gearbox wear

The performance characteristics of each motor are shown in a family of curves as above, from which torque, power and air consumption can be read off as a function of speed. Power is zero when the motor is stationary and also when running at free speed (100%) with no load. Maximum power (100%) is normally developed when the motor is driving a load at approximately half the free speed (50%). Torque at free speed is zero, but increases as soon as a load is applied, rising linearly until the motor stalls. As the motor can then stop with the vanes in various positions, it is not possible to specify an exact torque. However, a minimum starting torque is shown in all tables. Air consumption is greatest at free speed, and decreases with decreasing speed, as shown in the above diagram.

P1VAS  
 Stainless Steel  
 Air Motors

**Performance**

The performance of an air motor is dependent on the inlet pressure. At a constant inlet pressure, air motors exhibit the characteristic linear output torque / speed relationship. However, by simply regulating the air supply, using the techniques of throttling or pressure regulation, the output of an air motor can easily be modified. The most economical operation of an air motor (least wear, least air consumption, etc.) is reached by running close to nominal speed. By torque of  $M = 0$ , the maximum speed (idle speed) is reached. Shortly before standstill ( $n = 0$ ), the air motor reaches its maximum torque ( $M_{max} = 2 \times M_o$ ). At nominal speed ( $n_n$ ), for example in the middle of the speed range, air motor reaches its maximum power output ( $P_{max}$ ).

**Energy Efficiency**

A pneumatic motor achieves its maximum power when it is operating as close as possible to its rated speed (50% of the rated idle speed). The energy balance is best in this area, because the compressed air is used efficiently.

**Air pressure correction factors**

To adapt the difference of air pressure with your operation conditions

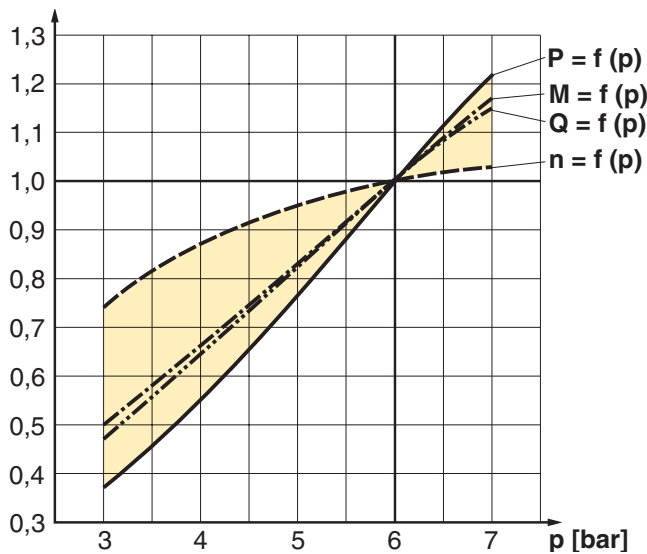

P = Power, M = Torque, Q = Air consumption, n = Speed

Pressure [p] bar / PSI	Power [P] %	Speed [n] %	Torque [M] %	Air Consump. [Q] %
7 / 99	121	103	117	117
6 / 85	100	100	100	100
5 / 71	77	95	83	83
4 / 57	55	87	67	67
3 / 42	37	74	50	50

All catalog data and curves are specified at a supply pressure of 6 bar to the motor. This diagram shows the effect of pressure on speed, specified torque, power and air consumption.

Start off on the curve at the pressure used and then look up to the lines for power, torque and air consumption. Read off the correction factor on the Y axis for each curve and multiply this by the specified catalogue data in the table, or data read from the torque and power graphs.

Example: at 4 bar supply pressure, the power is only 0.55 x power at 6 bar supply pressure. This example shows how strongly power falls if supply pressure is reduced. You must therefore ensure that the motor is supplied through pipes of sufficient diameter to avoid pressure drop.

The speed and torque can also be regulated by installing a pressure regulator in the inlet pipe. This means that the motor is constantly supplied with air at lower pressure, which means that when the motor is braked, it develops a lower torque on the output shaft.

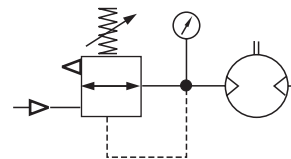

Pressure regulation at motor inlet.

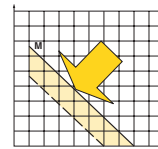

Theoretically torque curve change caused by pressure change

**Speed regulation, air flow reduction**

Every size reduction or restriction on the air line, whether of the supply hose itself or fittings, before the air motor affects the amount of the supplied air. By throttling you reduce the speed of your motor and simultaneously, the required torque. That means that you reduce the motor performance. The most common way to reduce the speed of a motor is to install a flow control valve in the air outlet, you can set the speed without loss of the torque. When the motor is used in applications where it must reverse and it is necessary to restrict the speed in both directions, flow control valves with by-pass should be used in both directions. If the inlet air is restricted, the air supply is restricted and the free speed of the motor falls, but there is full pressure on the vanes at low speeds. This means that we get full torque from the motor at low speeds despite the low air flow. Since the torque curve becomes "steeper", this also means that we get a lower torque at any given speed than would be developed at full air flow. The benefit of throttling the inlet is that air consumption is reduced, whereas throttling the exhaust air maintains a slightly higher starting torque.

P1VAS  
 Stainless Steel

Air Motors



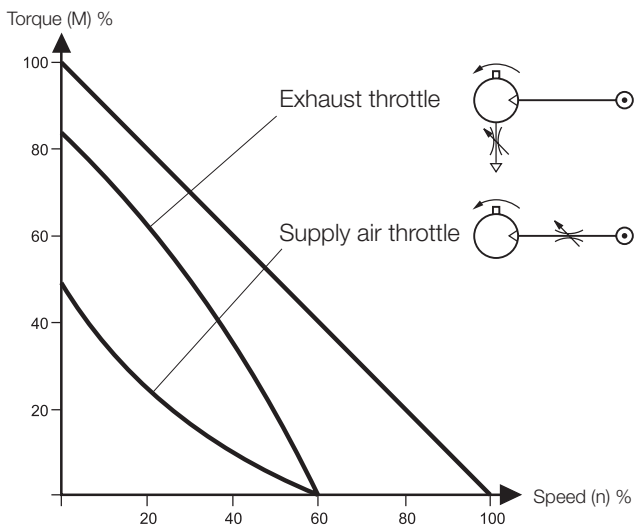

### Throttling

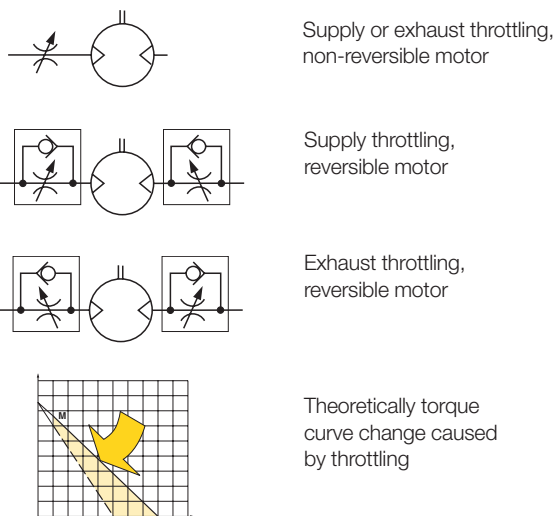

### Component choice for air supply

#### Direction of motor rotation

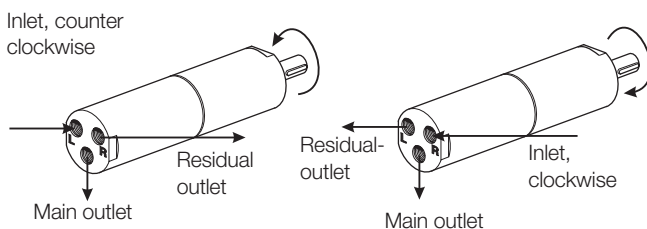

The direction of rotation of reversible motors is controlled by supplying inlet L or inlet R with compressed air. Air motors can be stopped and started continually without damage.

As the motor begins to rotate air is trapped between the vanes and is compressed. This air is exhausted through the exhaust port. As the rotor continues its rotation, trapped air is compressed and exhausted through the residual port. If this air is not exhausted, the motor will be braked and maximum power will not be obtained.

### Compressed air quality

Oil and oil mist are avoided whenever possible to ensure a clean work environment. In addition, purchasing, installation and maintenance of oil equipment can be expensive. All users in all industries now try to avoid using components which have to be lubricated. The P1V air motors series are equipped with vanes for intermittent lubrication free operation as standard, which is the most common application of air motors.

### Dry unlubricated compressed air



If unlubricated compressed air is used, the compressed air should comply with the purity standards below in order to guarantee the longest possible overall service life. If the unlubricated compressed air has a high water content, condensation forms inside the motor, causing corrosion in all internal components. A ball bearing can be destroyed in a remarkably short time if it comes into contact with a single water droplet. For indoor use, we recommend ISO8573-1 purity class 3.4.1. To achieve this, compressors must be fitted with after coolers, oil filters, refrigerant air dryers and air filters. For indoor/outdoor use, we recommend ISO8573-1 purity class 1.2.1.

To achieve this, compressors must be fitted with after coolers, oil filters, adsorption dryers and dust filters.

### Oil mist



If oil mist is used (approx. 1 drop of oil per m3 of compressed air), the oil not only acts as a lubricant but also protects against corrosion. This means that compressed air with a certain water content may be used without causing corrosion problems inside the motor. ISO8573-1 purity class 3.-.5 may be used without difficulty. The following oils are recommended for use in the food stuffs industry: Shell Cassida Fluid HF 32 or Klüberoil 4 UH 1-32

### ISO 8573-1 purity classes

Quality class	Contaminants		Water	Oil
	particle size ( $\mu\text{m}$ )	max. concentration ( $\text{mg}/\text{m}^3$ )	max. pressure dew point ( $^{\circ}\text{C}$ )	max. concentration ( $\text{mg}/\text{m}^3$ )
1	0.1	0.1	-70	0.01
2	1	1	-40	0.1
3	5	5	-20	1.0
4	15	8	+3	5.0
5	40	10	+7	25
6	-	-	+10	-

For example: compressed air to purity class 3.4.3. This means a 5  $\mu\text{m}$  filter (standard filter), dew point  $+3^{\circ}\text{C}$  (refrigerant cooled) and an oil concentration of 1,0 mg oil/m3 (as supplied by a standard compressor with a standard filter).

**Air supply**

Since the supply pressure at the air motor inlet port is of considerable importance for obtaining the power, speed and torque quoted in the catalogue, the recommendations below should be observed.

The following data must be complied with:

- Supply pressure: 7 bar
- Regulator pressure setting: 6.7 bar
- Pipe length between air treatment unit and valve: max. 1 m
- Pipe length valve and air motor: max 2 m

The pressure drop through the air preparation unit, pipe, valve means that 6 bar pressure is obtained at the motor supply port. Please refer to the correction diagram and factors to see what lower supply pressure means for power, speed and torque.

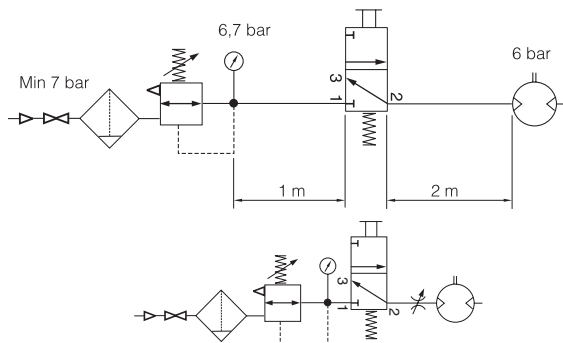

Shut-off, filtering, pressure regulation and control valve

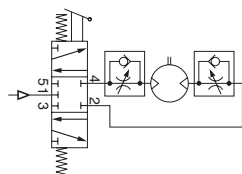

Reversible motor with 5/3 control valve

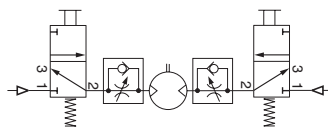

Reversible motor with two 3/2 control valves

The air with which the motor is supplied must be filtered and regulated. Directional valves are needed to provide it with air, to get the motor to rotate when we want it to. These valves can be equipped with several means of actuation, such as electric, manual and pneumatic control. When the motor is used in a non-reversible application, it is sufficient to use a 2/2 or 3/2 valve function for supply. Either one 5/3 or two 3/2 valves functions are needed for a reversible motor, to ensure that the motor receives compressed air and the residual air outlet is vented. A flow control valve can be installed in the supply pipe to regulate the motor speed if the motor is not used as a reversible motor.

One flow control valve with by-pass is needed to regulate each direction of rotation if the motor is used as a reversible motor. The built-in check valve will then allow air from the residual air outlet to escape through the outlet port in the control valve. The compressed air supply must have sufficiently large pipes and valves to give the motor the maximum power. The motor needs 6 bar at the supply port all the time. For example, a reduction of pressure to 5 bar reduces the power developed to 77% and to 55% at 4 bar!

**Air Motors  
P1VAS Series**

**Silencing**

Exhaust silencer

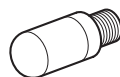

Central silencer

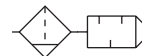

The noise from an air motor consists of both mechanical noise and a pulsating noise from the air flowing out of the outlet. The installation of the motor has a considerable effect on mechanical noise. It should be installed so that no mechanical resonance effects can occur. The outlet air creates a noise level which can amount to 115 dB(A) if the air is allowed to exhaust freely into the atmosphere. Various types of exhaust silencers are used to reduce this level. The most common type screws directly onto the exhaust port of the motor. Since the motor function causes the exhaust air to pulsate, it is a good idea to allow the air to exhaust into some kind of chamber first, which reduces the pulsations before they reach the silencer. The best silencing method is to connect a soft plastic hose to a large central silencer with the largest possible area, to reduce the speed of the out-flowing air as far as possible.

**NOTE!** Remember that if a silencer which is too small or is blocked, generates back pressure on the outlet side of the motor, which reduces the motor power.

**CE marking**

The air motors are supplied as “Components for installation” – the installer is responsible for ensuring that the motors are installed safely in the overall system. Parker Pneumatic guarantees that its products are safe, and as a supplier of pneumatic equipment we ensure that the equipment is designed and manufactured in accordance with the applicable EU directive.

Most of our products are classed as components as defined by various directives, and although we guarantee that the components satisfy the fundamental safety requirements of the directives to the extent that they are our responsibility, they do not usually carry the CE mark. Nevertheless, most P1VAS motors carry the CE mark because they are ATEX certified (for use in explosive atmospheres).

The following are the currently applicable directives:

- Machinery Directive(essential health and safety requirements relating to the design and structure of machines and safety components)
- EMC Directive
- Simple Pressure Vessels Directive
- Low Voltage Directive
- ATEX Directive (ATEX = ATmosphere EXplosive)



**Torque, power and air consumption graphs**

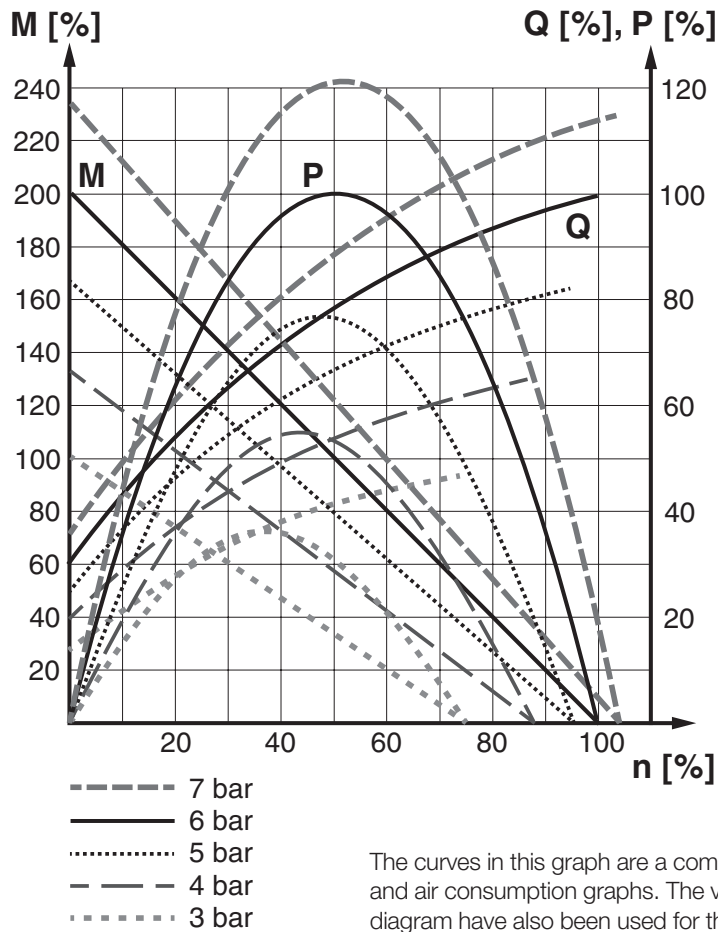

**P = power**      **Q = air consumption**  
**M = torque**      **n = speed**

**Choice of an air motor, general**

The motor to be used should be selected by starting with the torque needed at a specific spindle speed. In other words, to choose the right motor, you have to know the required speed and torque. Since maximum power is reached at half the motor's free speed, the motor should be chosen so that the point aimed at is as close as possible to the maximum power of the motor.

The design principle of the motor means that higher torque is generated when it is braked, which tends to increase the speed. This means that

the motor has a kind of speed self regulation function built in. Use the following graph to choose the correct motor size and the correct type of gear as appropriate. The graph contains the points for the maximum torque of each motor at maximum power. Put in your point on the graph and select a marked point above and to the right of the point you need.

The curves in this graph are a combination of the torque, power and air consumption graphs. The values from the correction diagram have also been used for the curves for the different pressure values. The graph also shows that it is very important to ensure that the pressure supplied to the inlet port of the motor is correct, in order to allow the motor to work at maximum capacity. If the valve supplying a large motor is too small or if the supply line is underspecified, the pressure at the inlet port may be so low that the motor is unable to do its work. One solution would be to upgrade the valve and supply system, or alternatively you could replace the motor with a smaller motor with lower air consumption. The result would be increased pressure at the inlet port, which means that the smaller motor could carry out the necessary work. However, you may need to select a smaller motor with a lower free speed in order to obtain sufficient torque at the outgoing shaft.

Then check the characteristic graph of each motor to find more accurate technical data. Always select a motor where the data required is in the orange field. Also use the correction diagram to see what it would mean to use different air supply pressures or different air flow in the motor.

Tip: Select a motor which is slightly too fast and powerful, regulate its speed and torque with a pressure regulator and/or restriction to achieve the optimum working point.

Do you need any support to select the right air motor, please feel free to consult your local sales office.

P1VAS  
Stainless Steel  
Air Motors



For inventory, lead times, and kit lookup, visit [www.pdnplu.com](http://www.pdnplu.com)



## Specifying air quality (purity) in accordance with ISO8573-1:2010, the international standard for compressed air quality

ISO8573-1 is the primary document used from the ISO8573 series as it is this document which specifies the amount of contamination allowed in each cubic metre of compressed air.

ISO8573-1 lists the main contaminants as Solid Particulate, Water and Oil. The purity levels for each contaminant are shown separately in tabular form, however for ease of use, this document combines all three contaminants into one easy to use table.

ISO8573-1:2010 CLASS	Solid Particulate			Mass Concentration mg/m <sup>3</sup>	Water		Oil
	Maximum number of particles per m <sup>3</sup>				Vapor Pressure Dewpoint	Liquid g/m <sup>3</sup>	
	0,1 - 0,5 micron	0,5 - 1 micron	1 - 5 micron				mg/m <sup>3</sup>
0	As specified by the equipment user or supplier and more stringent than Class 1						
1	≤ 20 000	≤ 400	≤ 10	-	≤ -70 °C	-	0,01
2	≤ 400 000	≤ 6 000	≤ 100	-	≤ -40 °C	-	0,1
3	-	≤ 90 000	≤ 1 000	-	≤ -20 °C	-	1
4	-	-	≤ 10 000	-	≤ +3 °C	-	5
5	-	-	≤ 100 000	-	≤ +7 °C	-	-
6	-	-	-	≤ 5	≤ +10 °C	-	-
7	-	-	-	5 - 10	-	≤ 0,5	-
8	-	-	-	-	-	0,5 - 5	-
9	-	-	-	-	-	5 - 10	-
X	-	-	-	> 10	-	> 10	> 10

### Specifying air purity in accordance with ISO8573-1:2010

When specifying the purity of air required, the standard must always be referenced, followed by the purity class selected for each contaminant (a different purity class can be selected for each contamination if required).

An example of how to write an air quality specification is shown below:

#### ISO 8573-1:2010 Class 1.2.1

ISO 8573-1:2010 refers to the standard document and its revision, the three digits refer to the purity classifications selected for solid particulate, water and total oil. Selecting an air purity class of 1.2.1 would specify the following air quality when operating at the standard's reference conditions:

#### Class 1 - Particulate

In each cubic meter of compressed air, the particulate count should not exceed 20,000 particles in the 0.1 - 0.5 micron size range, 400 particles in the 0.5 - 1 micron size range and 10 particles in the 1 - 5 micron size range.

#### Class 2 - Water

A pressure dewpoint (PDP) of -40°C or better is required and no liquid water is allowed.

#### Class 1 - Oil

In each cubic meter of compressed air, not more than 0.01mg of oil is allowed. This is a total level for liquid oil, oil aerosol and oil vapor.

### ISO8573-1:2010 Class zero

- Class 0 does not mean zero contamination.
- Class 0 requires the user and the equipment manufacturer to agree contamination levels as part of a written specification.
- The agreed contamination levels for a Class 0 specification should be within the measurement capabilities of the test equipment and test methods shown in ISO8573 Pt 2 to Pt 9.
- The agreed Class 0 specification must be written on all documentation to be in accordance with the standard.
- Stating Class 0 without the agreed specification is meaningless and not in accordance with the standard.
- A number of compressor manufacturers claim that the delivered air from their oil-free compressors is in compliance with Class 0.
- If the compressor was tested in clean room conditions, the contamination detected at the outlet will be minimal. Should the same compressor now be installed in typical urban environment, the level of contamination will be dependent upon what is drawn into the compressor intake, rendering the Class 0 claim invalid.
- A compressor delivering air to Class 0 will still require purification equipment in both the compressor room and at the point of use for the Class 0 purity to be maintained at the application.
- Air for critical applications such as breathing, medical, food, etc typically only requires air quality to Class 2.2.1 or Class 2.1.1.
- Purification of air to meet a Class 0 specification is only cost effective if carried out at the point of use.



For inventory, lead times, and kit lookup, visit [www.pdnplu.com](http://www.pdnplu.com)

## Maximize Your Air Motor Application with the P3X Lite

The P3X Lite air preparation system is constructed from ultra light weight technopolymers instead of the traditional aluminium or zinc die cast, making it 45% lighter than conventional units.

This non-metal construction also means that the P3X Lite is corrosion free enabling it to be used in harsh industrial environments where anti freeze or aggressive synthetic oils are present.

The use of technopolymers in the design of P3X Lite has facilitated a universal body design, this has resulted in reducing the number of variants required to cover the full spectrum of applications. This can dramatically lower logistic costs and simplify stock holding for customers making the P3X Lite a very cost effective solution.



P1VAS  
Stainless Steel

Air Motors

# Nano Mist

## Nano Mist Technology Self-Adjusting Lubricator

With conventional lubricators, only the oil volume per time unit can be adjusted. If the demand changes, the quantity move to be on one line, not split in two still remains constant.

The P3X Lite lubricator concept sets new benchmarks here. For the first time, the oil volume is automatically adjusted to the flow rate. This ensures that there is neither too little nor too much oil in the system, which leads to clear economic and ecological advantages.

In addition, with conventional systems, the distance between the lubricator and the equipment has to be less than 8 meters. With larger distances, the dispensed oil is deposited as a wall flow.

The new lubricator principle of the P3X Lite allows for distances of up to 40 meters. This opens up new scope for the design of even more efficient production systems.



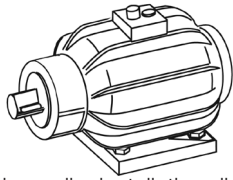

Air motors have much smaller installation dimensions than corresponding electric motors.

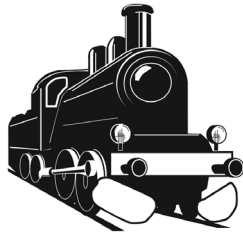

Air motors can be loaded until they stall, without damage. They are designed to be able to withstand the toughest heat, vibration, impact etc.

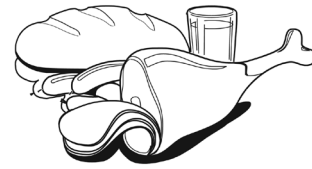

The shape, design and non-lubricated operation allow the motor to be suitable for use in the food industry.



Air motors can be stopped and started continually without damage.

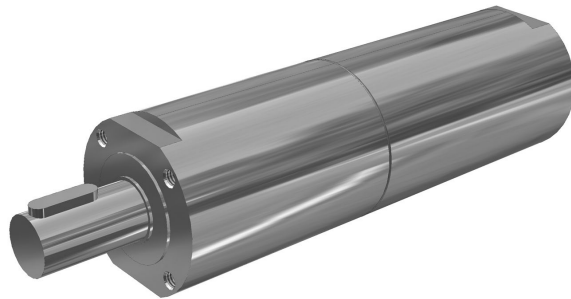

The weight of an air motor is several times less than corresponding electric motors.

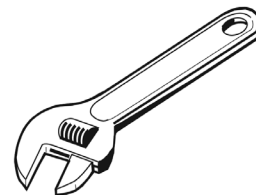

The simple design principle of air motors makes them very easy to service.

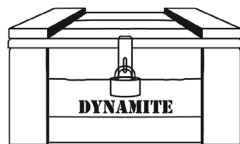

Air motors can be used in the harshest environments. Most P1VAS motors are ATEX certified.

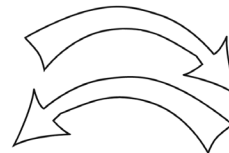

The motors are reversible as standard.



The choice of materials means that they can be used in damp and aggressive environments.



The reliability of air motors is very high, thanks to the design and the low number of moving parts.

P1VAS  
Stainless Steel

Air Motors



**P1VAS stainless steel type - 0.02 to 1.2 kW**

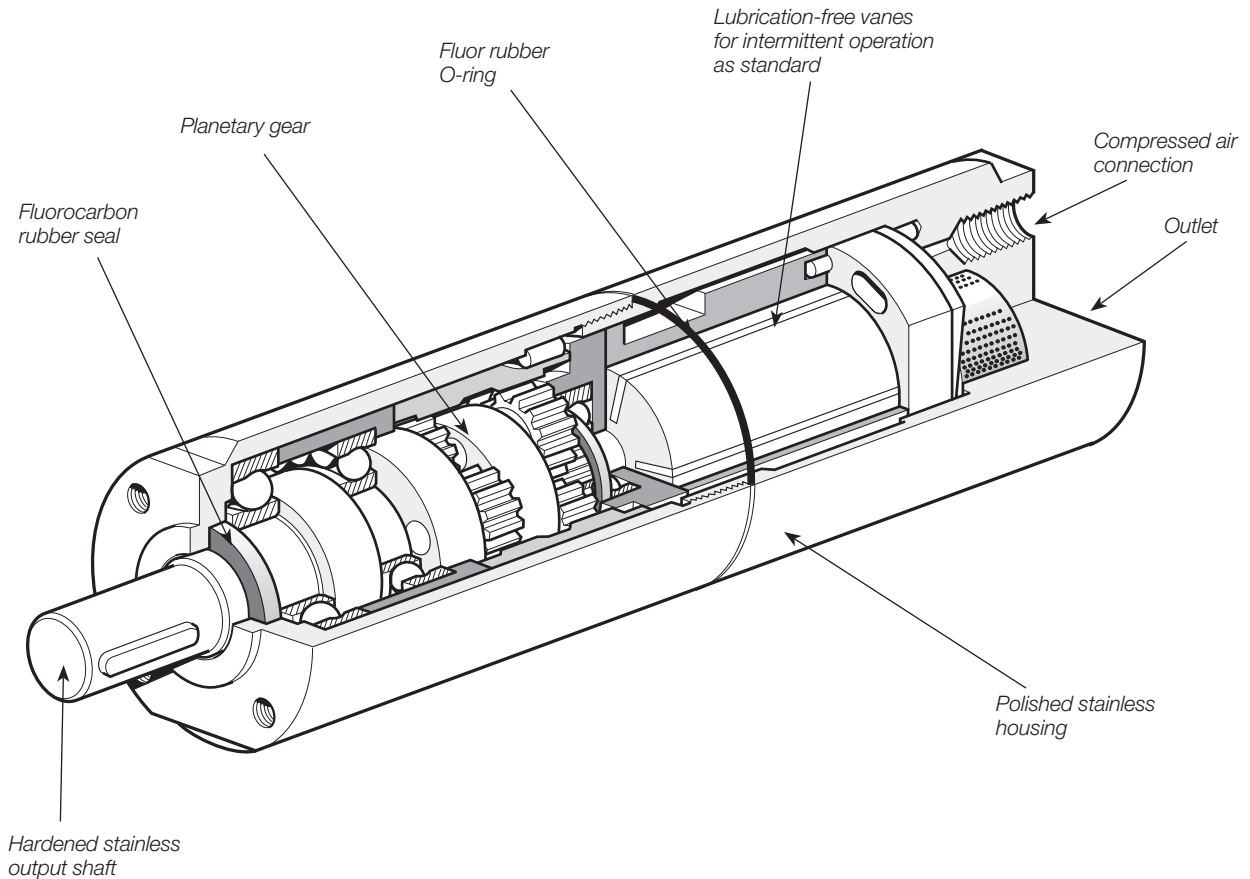

P1VAS  
Stainless Steel

Air Motors

**Stainless Steel Air Motors**

P1VAS is a range of air motors with all external components made of stainless steel, which means that they can be used in food grade applications, and in all other applications where there is a risk of corrosion.

The range contains seven different sizes, with power ranging from 120 to 1600 Watts, and speeds from 50 to 22,000 rpm. The air motor and planetary reduction gear are built into a polished stainless steel housing, which is sealed by a fluorocarbon rubber O-ring. The output shaft, which is made of polished stainless steel, is also sealed by a fluorocarbon rubber seal.

Consideration for achieving a clean, hygienic design was given early on in the development of this range of air motors. Thanks to the cylindrical shape, there are no pockets which can

accumulate dirt or bacteria. Additionally, the two halves of the motor body are sealed with an o-ring to prevent contamination. The choice of materials reflects the fact that aggressive cleaning materials are used in food grade applications.

The P1VAS series is designed to be operated in intermittent intervals under non-lubrication conditions. For this reason, no particles of lubricant escape with the exhaust air and the service costs are reduced. This means that the motors can be used directly in food grade applications. The planetary gear, which has one or more reduction stages, is lubricated with an USDA-H1 standard grease, approved for use in food grade applications.



For inventory, lead times, and kit lookup, visit [www.pdnplu.com](http://www.pdnplu.com)

**Technical data**

**Note:**

All technical data are based on a working pressure of 6 bar and with oil. Speed tolerance accuracy in between clock and anti-clockwise directions is ±10%.

Air Motor Size & Type	P1VAS012	P1VAS020	P1VAS030	P1VAS060	P1VAS090	P1VAS160
Nominal power (watts)	120	200	300	600	900	1600
Working pressure (bar)	3 to 7, 6 in explosive atmosphere					
Working temperature (°C)	-20 to +110					
Ambient temperature (°C)	-20 to +40 in explosive atmosphere					
Air flow required (NI/min)	300	370	470	850	1400	1600
Min pipe ID, inlet (mm)	6	10	10	12	12	19
Min pipe ID, outlet (mm)	6	10	10	12	12	19
<b>Choice of treatment unit: recommended min air flow (l/min) at p1 7.5 bar and 0.8 bar pressure drop</b>						
	340	410	510	900	1500	1800
Medium	40µm filtered, oil mist or dry unlubricated compressed air					
Oil free operation, indoor	ISO8573-1 purity class 3.4.1					
Oil free operation, outdoor	ISO8573-1 purity class 1.2.1					
Oil operation	1-2 drop per cube meter, ISO8573-1 purity class 3.-.5					
Recommended oil	Foodstuffs industry Klüber oil 4 UH1- 32 N					
<b>Choice of valve: recommended min nominal air flow (l/min) at p1 6 bar and 1 bar pressure drop</b>						
	380	450	550	950	1600	2000
Sound level free outlet (dB(A))	99	100	103	103	106	108
With outlet silencer (dB(A))	92	82	91	94	88	95
Exhaust air removed with pipes to another room	70	71	70	76	80	87

**Note:**

sound levels are measured at free speed with the measuring instrument positioned 1 meter away from the air motor at an height of 1 meter.

**Material specification**

Air Motor Size & Type	P1VAS012	P1VAS020	P1VAS030	P1VAS060	P1VAS090	P1VAS160
Planetary gearbox housing	Stainless Steel					
Air motor housing	Stainless steel					
Shaft	Hardened stainless steel					
Key	Hardened stainless steel					
External seal Fluor rubber	Fluor rubber FPM					
Internal steel parts	High grade steel (not stainless)					
Planetary gear grease used in	Grease, Shell Cassida RLS2					
Screws in housing in last planet stage	Surface treated steel					

**Accessories**

**P1V**

Flange bracket	Stainless steel
Foot bracket	Stainless steel
Screws for the mountings	Stainless steel DIN A2



For inventory, lead times, and kit lookup, visit [www.pdnplu.com](http://www.pdnplu.com)



Choice of vanes

**0 = Standard vanes**

These motors are for the vane type for intermittent lubrication-free operation. They can operate 70% of the time for up to 15 minutes without lubrication. With lubrication, these motors can operate 100% of the time.

**C = Vanes for continuous lubrication-free operation**

This motor is equipped with vanes for continuous lubrication-free operation. (To obtain the longest possible service life, we recommend no oil in the air.)

**Z = Standard spring loaded vanes**

All vanes are spring loaded to ensure that they remain pressed against the cylinder when the motor stops. The spring loaded vane option also prevents the vanes from sliding down in their track if vibration is introduced. The spring loaded vanes therefore provide a higher starting torque, improved starting and low speed characteristics, because the leakage over the vanes is reduced to a minimum.

Refer to the model code on page 27 for ordering vanes with option C or Z.

**ATEX Classes**

T6   T80°C	II 2G Ex h IIC T6 Gb X II 2D Ex h IIIC T80°C Db X
T5   95°C	II 2G Ex h IIC T5 Gb X II 2D Ex h IIIC T95°C Db X
T4   T130°C	II 2G Ex h IIC T4 Gb X II 2D Ex h IIIC T130°C Db X
T3   T195°C	II 2G Ex h IIC T3 Gb X II 2D Ex h IIIC T195°C Db X

**Optimum working speed and torque range**

The performance characteristics of each motor are normally shown in a family of curves, from which torque, power and air consumption can be read off as a function of speed.

Power is zero when the motor is stationary and also when running at free speed (100%) with no load. Maximum power (100%) is normally developed when the motor is driving a load at approximately half the free speed (50%). Torque at free speed is zero, but increases as soon as a load is applied, rising linearly until the motor stalls. As the motor can then stop with the vanes in various positions, it is not possible to specify an exact torque. However, a minimum starting torque is shown in all tables in next pages for each air motor size. Air consumption is greatest at free speed, and decreases with decreasing speed.

Order Code	6 bar	
	Speed Range [rpm]	Torque Range [Nm]
P1VAS012A*N00	8800 to 11000	0,12 to 0,1
P1VAS012A*550	2200 to 2750	0,46 to 0,4
P1VAS012A*360	1440 to 1800	0,69 to 0,6
P1VAS012A*140	560 to 700	1,84 to 1,6
P1VAS012A*090	360 to 450	2,88 to 2,5
P1VAS012A*060	240 to 300	4,37 to 3,8
P1VAS012A*010	-	-
P1VAS020A*G00	6400 to 8000	0,28 to 0,24
P1VAS020A*460	1840 to 2300	0,92 to 0,8
P1VAS020A*240	960 to 1200	1,84 to 1,6
P1VAS020A*140	560 to 700	3,11 to 2,7
P1VAS020A*070	280 to 350	6,21 to 5,4
P1VAS020A*036	144 to 180	12,19 to 10,6
P1VAS020A*018	72 to 90	12,08 to 10,5
P1VAS020A*005	-	-
P1VAS030A*E50	5800 to 7250	0,46 to 0,4
P1VAS030A*460	1840 to 2300	1,38 to 1,2
P1VAS030A*240	960 to 1200	2,76 to 2,4
P1VAS030A*123	492 to 615	5,35 to 4,65
P1VAS030A*070	280 to 350	9,37 to 8,15
P1VAS030A*036	144 to 180	18,29 to 15,9
P1VAS030A*018	72 to 90	15,87 to 13,8
P1VAS030A*010	-	-
P1VAS030A*005	-	-

Order Code	6 bar	
	Speed Range [rpm]	Torque Range [Nm]
P1VAS060A*D50	5400 to 6750	0,98 to 0,85
P1VAS060A*550	2200 to 2750	2,3 to 2
P1VAS060A*400	1600 to 2000	3,22 to 2,8
P1VAS060A*300	1200 to 1500	4,37 to 3,8
P1VAS060A*200	800 to 1000	6,56 to 5,7
P1VAS060A*070	280 to 350	18,75 to 16,3
P1VAS060A*050	200 to 250	26,34 to 22,9
P1VAS060A*034	136 to 170	38,76 to 33,7
P1VAS060A*018	72 to 90	36,57 to 31,8
P1VAS090A*C60	5040 to 6300	1,55 to 1,35
P1VAS090A*520	2080 to 2600	3,8 to 3,3
P1VAS090A*367	1468 to 1835	5,29 to 4,6
P1VAS090A*285	1140 to 1425	6,9 to 6
P1VAS090A*190	760 to 950	10,35 to 9
P1VAS090A*065	260 to 325	30,36 to 26,4
P1VAS090A*047	188 to 235	41,98 to 36,5
P1VAS090A*031	124 to 155	63,71 to 55,4
P1VAS160A*960	3840 to 4800	3,57 to 3,1
P1VAS160A*250	1000 to 1250	14,03 to 12,2
P1VAS160A*120	480 to 600	29,21 to 25,4
P1VAS160A*070	280 to 350	50,14 to 43,6
P1VAS160A*032	128 to 160	109,71 to 95,4
P1VAS160A*020	80 to 100	76,94 to 66,9
P1VAS160A*016	64 to 80	219,65 to 191

\* valid for vanes 0, C, Z.

P1VAS  
Stainless Steel

Air Motors



For inventory, lead times, and kit lookup, visit [www.pdnplu.com](http://www.pdnplu.com)





**P1VAS Stainless Steel Vane Air Motors with Integrated Planetary Gear boxes**

**Note:**

All technical data are based on a working pressure of 6 bar and with oil lubrication. With oil free operation performances are reduced by 10 to 20%. Speed tolerance accuracy in between clock and anti clockwise directions is ±10%. Note! Inlet and exhaust air flows are critical for reaching the best performances.

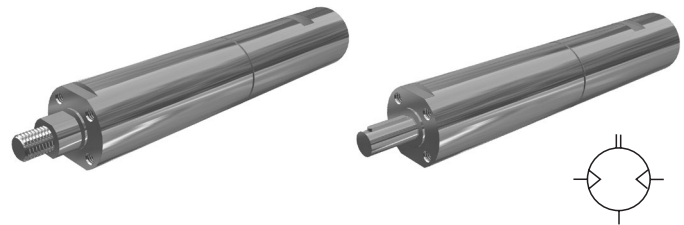

**Data for Reversible Air Motor Power 120 watts, with Keyed Shaft**

Max Power [watt]	Free Speed [rpm]	Nominal Speed [rpm]	Nominal Torque [Nm]	Min Starting Torque [Nm]	Stall Torque [Nm]	Max Adm Torque [Nm]	Air Consumption [m3/mm]	Supply/Exhaust	Min Pipe [mm]	Weight [kg]	ATEX	Temp	Rotation	Vane Option	Order Code
120	22000	11000	0,10	0,15	0,19	-	0,30	G1/8   G1/8	6   6	0,35	T6	T80°C	L & R	0, C, Z	P1VAS012A0N00
120	5500	2750	0,40	0,60	0,76	-	0,30	G1/8   G1/8	6   6	0,35	T4	T130°C	L & R	0, C, Z	P1VAS012A0550
120	3600	1800	0,60	0,90	1,14	-	0,30	G1/8   G1/8	6   6	0,35	T4	T130°C	L & R	0, C, Z	P1VAS012A0360
120	1400	700	1,60	2,40	3,00	-	0,30	G1/8   G1/8	6   6	0,40	T4	T130°C	L & R	0, C, Z	P1VAS012A0140
120	900	450	2,50	3,80	4,70	-	0,30	G1/8   G1/8	6   6	0,40	T6	T80°C	L & R	0, C, Z	P1VAS012A0090
120	600	300	3,80	-	-	-	0,30	G1/8   G1/8	6   6	0,40	T6	T80°C	L & R	0, C, Z	P1VAS012A0060
120	100	-	-	-	-	-	0,30	G1/8   G1/8	6   6	0,45	T6	T80°C	L & R	0, C, Z	P1VAS012A0010

**With Threaded Shaft**

120	22000	11000	0,10	0,15	0,19	-	0,30	G1/8   G1/8	6   6	0,35	T6	T80°C	-	0, C, Z	P1VAS012D0N00
120	5500	2750	0,40	0,60	0,76	-	0,30	G1/8   G1/8	6   6	0,35	T4	T130°C	-	0, C, Z	P1VAS012D0550
120	3600	1800	0,60	0,90	1,14	-	0,30	G1/8   G1/8	6   6	0,35	T4	T130°C	-	0, C, Z	P1VAS012D0360
120	1400	700	1,60	2,40	3,00	-	0,30	G1/8   G1/8	6   6	0,40	T4	T130°C	-	0, C, Z	P1VAS012D0140
120	900	450	2,50	3,80	4,70	-	0,30	G1/8   G1/8	6   6	0,40	T6	T80°C	-	0, C, Z	P1VAS012D0090
120	600	300	3,80	-	-	-	0,30	G1/8   G1/8	6   6	0,40	T6	T80°C	-	0, C, Z	P1VAS012D0060
120	100	-	-	-	-	-	0,30	G1/8   G1/8	6   6	0,45	T6	T80°C	-	0, C, Z	P1VAS012D0010

Details on page 15

**Note:** air motor rotation with threaded shaft may be reversed, but when operated anticlockwise, there is a risk that the driven unit may disconnect if it is not locked properly.

\* Maximum admissible torque

No values as these motors can not achieve the maximum gear box torque. Nominal torque is the max they can achieve. The motor P1VAS012A0060 has no specification for the start torque and the stall torque because it is higher than 5 Nm. The motor P1VAS012A0010 has no specification for the nominal speed because if the motor reach the nominal speed then the max. adm. torque will be higher than 5 Nm.

P1VAS  
Stainless Steel

Air Motors



**120 watts**

[mm]

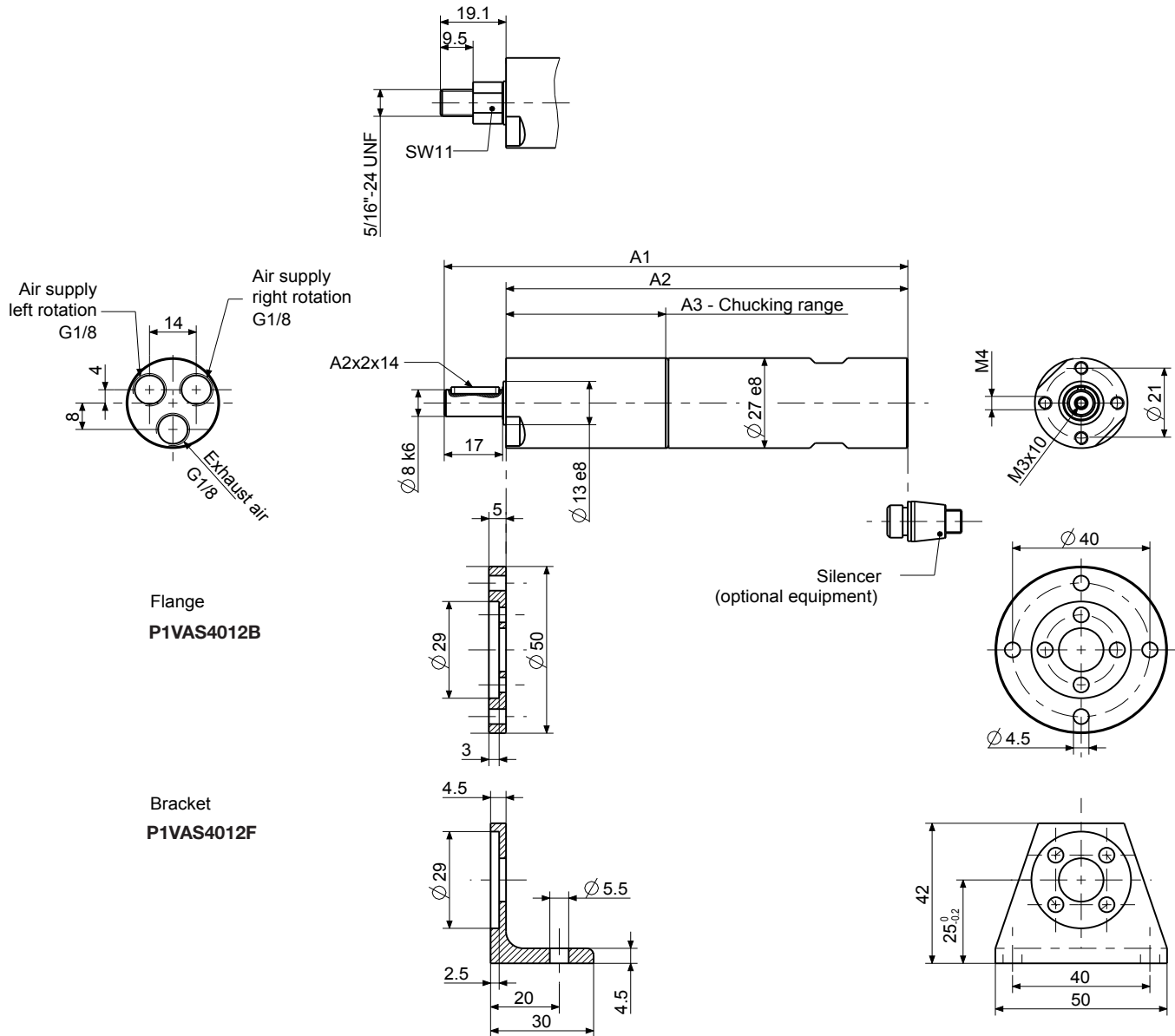

Flange  
**P1VAS4012B**

Bracket  
**P1VAS4012F**

Silencer  
(optional equipment)



**Dimension [mm] 120 watts**

A1	A2	A3	Part Number		
135	117	46,5	<b>P1VAS012A*N00</b>	<b>P1VAS012A*550</b>	<b>P1VAS012A*360</b>
147,5	129,5	59	<b>P1VAS012A*140</b>	<b>P1VAS012A*090</b>	<b>P1VAS012A*060</b>
160	142	71,5	<b>P1VAS012A*010</b>		

\* 0, C, Z



For inventory, lead times, and kit lookup, visit [www.pdnplu.com](http://www.pdnplu.com)

**P1VAS Stainless Steel Vane Air Motors with Integrated Planetary Gear boxes**

**Note:** All technical data are based on a working pressure of 6 bar and with oil lubrication. With oil free operation performances are reduced by 10 to 20%. Speed tolerance accuracy in between clock and anti clockwise directions is ±10%.

**Note!** Inlet and exhaust air flows are critical for reaching the best performances.



**Data for Reversible Air Motor Power 200 watts, with Keyed Shaft**

Max Power [watt]	Free Speed [rpm]	Nomi- nal Speed [rpm]	Nomi- nal Troque	Min Starting Torque [Nm]	Stall Torque [Nm]	Max Adm Torque [Nm]	Air Con- sumption [m3/mm]	Supply/ Exhaust	Min Pipe [mm]	Weight [kg]	ATEX	Rotation	Vane Option	Order Code
200	16000	8000	0,24	0,35	0,45	-	0,37	G1/8   G1/4	10   10	0,70	T6   T80°C	L & R	0, C, Z	P1VAS020A0G00
200	4600	2300	0,8	1,20	1,50	-	0,37	G1/8   G1/4	10   10	0,75	T4   T130°C	L & R	0, C, Z	P1VAS020A0460
200	2400	1200	1,6	2,40	3,00	-	0,37	G1/8   G1/4	10   10	0,75	T4   T130°C	L & R	0, C, Z	P1VAS020A0240
200	1400	700	2,7	4,10	5,10	-	0,37	G1/8   G1/4	10   10	0,85	T4   T130°C	L & R	0, C, Z	P1VAS020A0140
200	700	350	5,4	8,20	10,30	-	0,37	G1/8   G1/4	10   10	0,85	T6   T80°C	L & R	0, C, Z	P1VAS020A0070
200	360	180	10,6	15,90	-	20,00	0,37	G1/8   G1/4	10   10	0,85	T6   T80°C	L & R	0, C, Z	P1VAS020A0036
100	180	90	10,5	15,00	-	20,00	0,27	G1/8   G1/4	10   10	0,85	T6   T80°C	L & R	0, C, Z	P1VAS020A0018
180	50	-	-	-	-	20,00	0,34	G1/8   G1/4	10   10	0,95	T6   T80°C	L & R	0, C, Z	P1VAS020A0005

**With Threaded Shaft**

200	16000	8000	0,24	0,35	0,45	-	0,37	G1/8   G1/4	10   10	0,70	T6   T80°C	-	0, C, Z	P1VAS020D0G00
200	4600	2300	0,8	1,20	1,50	-	0,37	G1/8   G1/4	10   10	0,75	T4   T130°C	-	0, C, Z	P1VAS020D0460
200	2400	1200	1,6	2,40	3,00	-	0,37	G1/8   G1/4	10   10	0,75	T4   T130°C	-	0, C, Z	P1VAS020D0240
200	1400	700	2,7	4,10	5,10	-	0,37	G1/8   G1/4	10   10	0,85	T4   T130°C	-	0, C, Z	P1VAS020D0140
200	700	350	5,4	8,20	10,30	-	0,37	G1/8   G1/4	10   10	0,85	T6   T80°C	-	0, C, Z	P1VAS020D0070
200	360	180	10,6	15,90	-	20,00	0,37	G1/8   G1/4	10   10	0,85	T6   T80°C	-	0, C, Z	P1VAS020D0036
100	180	90	10,5	15,00	-	20,00	0,27	G1/8   G1/4	10   10	0,85	T6   T80°C	-	0, C, Z	P1VAS020D0018
180	50	-	-	-	-	20,00	0,34	G1/8   G1/4	10   10	0,95	T6   T80°C	-	0, C, Z	P1VAS020D0005

Max. adm torque is restriction from the gear box. Details on page 15

**Data for Reversible Air Motor Power 300 watts, with Keyed Shaft**

Max Power [watt]	Free Speed [rpm]	Nomi- nal Speed [rpm]	Nomi- nal Troque	Min Starting Torque [Nm]	Stall Torque [Nm]	Max Adm Torque [Nm]	Air Con- sumption [m3/mm]	Supply/ Exhaust	Min Pipe [mm]	Weight [kg]	ATEX	Rotation	Vane Option	Order Code
300	14500	7250	0,40	0,60	0,76	-	0,47	G1/8   G1/4	10   10	0,70	T6   T80°C	L & R	0, C, Z	P1VAS030A0E50
300	4600	2300	1,20	1,90	2,20	-	0,47	G1/8   G1/4	10   10	0,75	T4   T130°C	L & R	0, C, Z	P1VAS030A0460
300	2400	1200	2,40	3,60	4,50	-	0,47	G1/8   G1/4	10   10	0,75	T4   T130°C	L & R	0, C, Z	P1VAS030A0240
300	1230	615	4,65	6,95	8,80	-	0,47	G1/8   G1/4	10   10	0,85	T4   T130°C	L & R	0, C, Z	P1VAS030A0123
300	700	350	8,15	12,25	15,50	-	0,47	G1/8   G1/4	10   10	0,85	T6   T80°C	L & R	0, C, Z	P1VAS030A0070
300	360	180	15,90	23,80	30,20	-	0,47	G1/8   G1/4	10   10	0,85	T6   T80°C	L & R	0, C, Z	P1VAS030A0036
130	180	90	13,80	21,00	26,20	-	0,28	G1/8   G1/4	10   10	0,85	T6   T80°C	L & R	0, C, Z	P1VAS030A0018
300	100	-	-	-	-	36,00	0,47	G1/8   G1/4	10   10	0,95	T6   T80°C	L & R	0, C, Z	P1VAS030A0010
280	50	-	-	-	-	36,00	0,47	G1/4   G1/4	10   10	1,25	T6   T80°C	L & R	0, C, Z	P1VAS030A0005

**With Threaded Shaft**

300	14500	7250	0,40	0,60	0,76	-	0,47	G1/4   G1/4	10   10	1,00	T6   T80°C	-	0, C, Z	P1VAS030D0E50
300	4600	2300	1,20	1,90	2,20	-	0,47	G1/4   G1/4	10   10	1,05	T3   T195°C	-	0, C, Z	P1VAS030D0460
300	2400	1200	2,40	3,60	4,50	-	0,47	G1/4   G1/4	10   10	1,05	T4   T130°C	-	0, C, Z	P1VAS030D0240
300	1230	615	4,65	6,95	8,80	-	0,47	G1/4   G1/4	10   10	1,10	T4   T130°C	-	0, C, Z	P1VAS030D0123
300	700	350	8,15	12,25	15,50	-	0,47	G1/4   G1/4	10   10	1,15	T6   T80°C	-	0, C, Z	P1VAS030D0070
300	360	180	15,90	23,80	30,20	-	0,47	G1/4   G1/4	10   10	1,15	T6   T80°C	-	0, C, Z	P1VAS030D0036
130	180	90	13,80	21,00	26,20	-	0,28	G1/4   G1/4	10   10	1,15	T6   T80°C	-	0, C, Z	P1VAS030D0018
300	100	-	-	-	-	36,00	0,47	G1/4   G1/4	10   10	1,25	T6   T80°C	-	0, C, Z	P1VAS030D0010
280	50	-	-	-	-	36,00	0,47	G1/4   G1/4	10   10	1,25	T6   T80°C	-	0, C, Z	P1VAS030D0005

Max. adm torque is restriction from the gear box. Details on page 15

**Note:** air motor rotation with threaded shaft may be reversed, but when operated anticlockwise, there is a risk that the driven unit may disconnect if it is not locked properly.



For inventory, lead times, and kit lookup, visit [www.pdnplu.com](http://www.pdnplu.com)

200 and 300 watts

[mm]

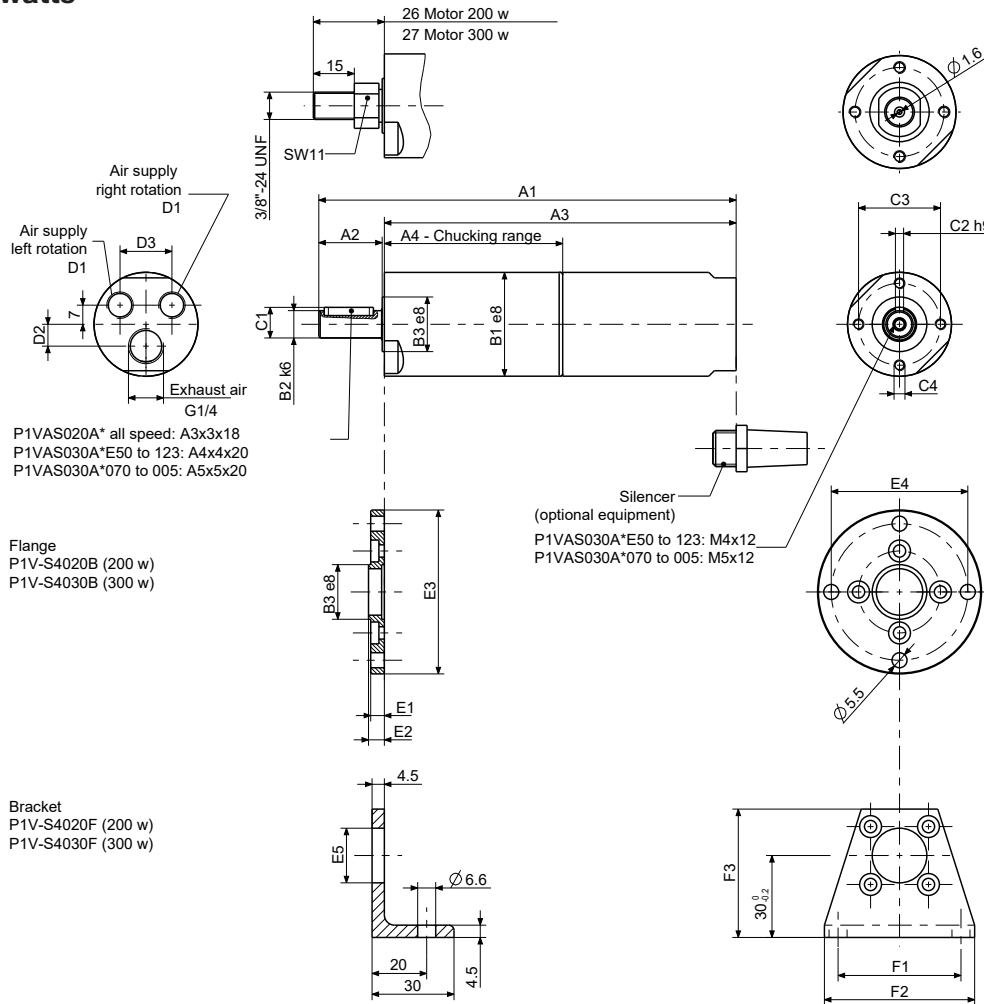

Dimension [mm] 200 watts

\* 0, C, Z

A1	A2	A3	A4	B1	B2	B3	C1	C2	C3	C4	Part Number		
152,5	23	128,5	65	38	10	20	11,2	3	30	M4	P1VAS020A*G00	P1VAS020A*460	P1VAS020A*240
168	23	144,5	81	38	10	20	11,2	3	30	M4	P1VAS020A*140	P1VAS020A*070	P1VAS020A*036 P1VAS020A*018
184,5	23	160,5	97	38	10	20	11,2	3	30	M4	P1VAS020A*005		
D1	D2	D3	B3	E1	E2	E3	E4	E5	F1	F2	F3	Part Number	
G1/8	8	19	20	5	5,8	60	50	17	45	55	47	P1VAS020A*G00	P1VAS020A*460 P1VAS020A*240
G1/8	8	19	20	5	5,8	60	50	17	45	55	47	P1VAS020A*140	P1VAS020A*070 P1VAS020A*036 P1VAS020A*018
G1/8	8	19	20	5	5,8	60	50	17	45	55	47	P1VAS020A*005	

Dimension [mm] 300 watts

A1	A2	A3	A4	B1	B2	B3	C1	C2	C3	C4	Part Number			
171	27	143	66	42	12	24	13,5	4	34	M5	P1VAS030A*E50	P1VAS030A*460	P1VAS030A*240	
187	27	159	83	42	12	24	13,5	4	34	M5	P1VAS030A*123			
191	30	159	83	42	14	24	16	5	34	M5	P1VAS030A*070	P1VAS030A*036	P1VAS030A*018	
196	30	164	83	42	14	24	16	5	34	M5	P1VAS030A*010	P1VAS030A*005		
D1	D2	D3	B3	E1	E2	E3	E4	E5	F1	F2	F3	Part Number		
G1/4	11	20	20	5	6,8	60	50	17	45	55	47	P1VAS030A*E50	P1VAS030A*460 P1VAS030A*240	
G1/4	11	20	20	5	6,8	60	50	17	45	55	47	P1VAS030A*123		
G1/4	11	20	24	6	6,8	65	55	21	50	60	48	P1VAS030A*070	P1VAS030A*036 P1VAS030A*018	
G1/4	11	20	24	6	6,8	65	55	21	50	60	48	P1VAS030A*010	P1VAS030A*005	



For inventory, lead times, and kit lookup, visit [www.pdnplu.com](http://www.pdnplu.com)

**P1VAS Stainless Steel Vane Air Motors with Integrated Planetary Gear boxes**

**Note:** All technical data are based on a working pressure of 6 bar and with oil lubrication. With oil free operation performances are reduced by 10 to 20%. Speed tolerance accuracy in between clock and anti clockwise directions is ±10%.

**Note!** Inlet and exhaust air flows are critical for reaching the best performances.

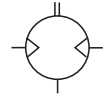

**Data for Reversible Air Motor Power 600 watts, with Keyed Shaft**

Max Power [watt]	Free Speed [rpm]	Nomi- nal Speed [rpm]	Nominal Torque	Min Starting Torque [Nm]	Stall Torque [Nm]	Max Adm Torque [Nm]	Air Consumption [m3/mm]	Supply/ Exhaust	Min Pipe [mm]	Weight [kg]	ATEX	Rotation	Vane Option	Part Number
600	13500	6750	0,85	1,25	1,60	-	0,85	G3/8   G1/2	12   12	2,20	T6   T80°C	L & R	0, C, Z	P1VAS060A0D50
600	5500	2750	2,00	3,10	3,90	-	0,85	G3/8   G1/2	12   12	2,70	T6   T80°C	L & R	0, C, Z	P1VAS060A0550
600	4000	2000	2,80	4,30	5,40	-	0,85	G3/8   G1/2	12   12	2,30	T3   T195°C	L & R	0, C, Z	P1VAS060A0400
600	3000	1500	3,80	5,70	7,20	-	0,85	G3/8   G1/2	12   12	2,30	T4   T130°C	L & R	0, C, Z	P1VAS060A0300
600	2000	1000	5,70	8,50	10,80	-	0,85	G3/8   G1/2	12   12	2,30	T4   T130°C	L & R	0, C, Z	P1VAS060A0200
600	700	350	16,30	24,50	31,10	-	0,85	G3/8   G1/2	12   12	2,60	T6   T80°C	L & R	0, C, Z	P1VAS060A0070
600	500	250	22,90	34,30	43,50	-	0,85	G3/8   G1/2	12   12	2,70	T6   T80°C	L & R	0, C, Z	P1VAS060A0050
600	340	170	33,70	50,60	64,00	-	0,85	G3/8   G1/2	12   12	2,70	T6   T80°C	L & R	0, C, Z	P1VAS060A0034
300	180	90	31,80	47,70	60,40	-	0,55	G3/8   G1/2	12   12	2,70	T6   T80°C	L & R	0, C, Z	P1VAS060A0018

Details on page 15

**Data for Reversible Air Motor Power 900 watts, with Keyed Shaft**

Max Power [watt]	Free Speed [rpm]	Nomi- nal Speed [rpm]	Nominal Torque	Min Starting Torque [Nm]	Stall Torque [Nm]	Max Adm Torque [Nm]	Air Consumption [m3/mm]	Supply/ Exhaust	Min Pipe [mm]	Weight [kg]	ATEX	Rotation	Vane Option	Part Number
900	12600	6300	1,35	2,00	2,60	-	1,40	G3/8   G1/2	12   12	3,55	T6   T80°C	L & R	0, C, Z	P1VAS090A0C60
900	5200	2600	3,30	4,90	6,20	-	1,40	G3/8   G1/2	12   12	3,55	T6   T80°C	L & R	0, C, Z	P1VAS090A0520
900	3670	1835	4,60	7,00	8,90	-	1,40	G3/8   G1/2	12   12	3,65	T3   T195°C	L & R	0, C, Z	P1VAS090A0367
900	2850	1425	6,00	9,00	11,40	-	1,40	G3/8   G1/2	12   12	3,65	T4   T130°C	L & R	0, C, Z	P1VAS090A0285
900	1900	950	9,00	14,50	17,10	-	1,40	G3/8   G1/2	12   12	3,65	T4   T130°C	L & R	0, C, Z	P1VAS090A0190
900	650	325	26,40	39,60	50,20	-	1,40	G3/8   G1/2	12   12	3,95	T6   T80°C	L & R	0, C, Z	P1VAS090A0065
900	470	235	36,50	54,80	69,40	-	1,40	G3/8   G1/2	12   12	3,95	T6   T80°C	L & R	0, C, Z	P1VAS090A0047
900	310	155	55,40	83,10	105,30	-	1,40	G3/8   G1/2	12   12	3,95	T6   T80°C	L & R	0, C, Z	P1VAS090A0031

Details on page 15

**Data for Reversible Air Motor Power 1600 watts, with Keyed Shaft**

Max Power [watt]	Free Speed [rpm]	Nomi- nal Speed [rpm]	Nominal Torque	Min Starting Torque [Nm]	Stall Torque [Nm]	Max Adm Torque [Nm]	Air Consumption [m3/mm]	Supply/ Exhaust	Min Pipe [mm]	Weight [kg]	ATEX	Rotation	Vane Option	Part Number
1600	9600	4800	3,10	4,70	6,05	-	1,60	G1/2   G3/4	19   19	5,90	T6   T80°C	L & R	0, C, Z	P1VAS160A0960
1600	2500	1250	12,20	18,30	23,20	-	1,60	G1/2   G3/4	19   19	6,10	T3   T195°C	L & R	0, C, Z	P1VAS160A0250
1600	1200	600	25,40	38,20	48,30	-	1,60	G1/2   G3/4	19   19	6,10	T4   T130°C	L & R	0, C, Z	P1VAS160A0120
1600	700	350	43,60	65,40	82,90	-	1,60	G1/2   G3/4	19   19	6,70	T4   T130°C	L & R	0, C, Z	P1VAS160A0070
1600	320	160	95,40	143,20	181,40	-	1,60	G1/2   G3/4	19   19	6,70	T4   T130°C	L & R	0, C, Z	P1VAS160A0032
700	200	100	66,90	100,00	125,00	-	1,60	G1/2   G3/4	19   19	6,70	T6   T80°C	L & R	0, C, Z	P1VAS160A0020
1600	160	80	191,00	-	-	220,00	1,60	G1/2   G3/4	19   19	8,00	T6   T80°C	L & R	0, C, Z	P1VAS160A0016

Max. adm torque is restriction from the gear box. Details on page 15

P1VAS  
Stainless Steel

Air Motors



For inventory, lead times, and kit lookup, visit [www.pdnplu.com](http://www.pdnplu.com)

600 watts

[mm]

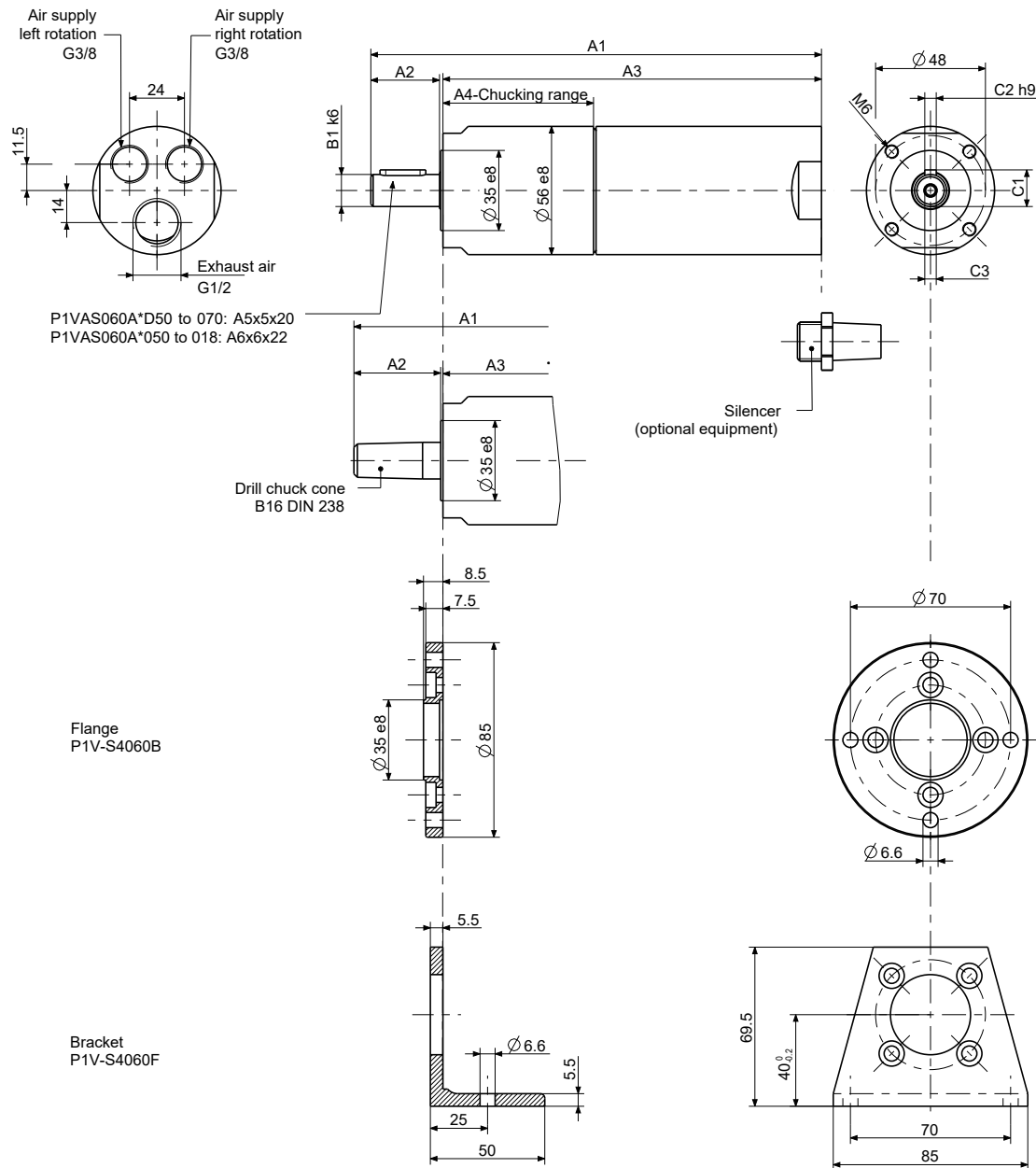

Dimension [mm] 600 watts

A1	A2	A3	A4	B1	C1	C2	C3	Part Number					
197	30,5	165,5	66	14	16	5	M5x12	P1VAS060A*D50	P1VAS060A*400	P1VAS060A*300	P1VAS060A*200		
215	30,5	183,5	84	14	16	5	M5x12	P1VAS060A*550	P1VAS060A*070				
217	35	180	80,5	19	21,5	6	M6x12	P1VAS060A*050	P1VAS060A*034	P1VAS060A*018			

\* 0, C, Z



For inventory, lead times, and kit lookup, visit [www.pdnplu.com](http://www.pdnplu.com)

**900 watts**

[mm]

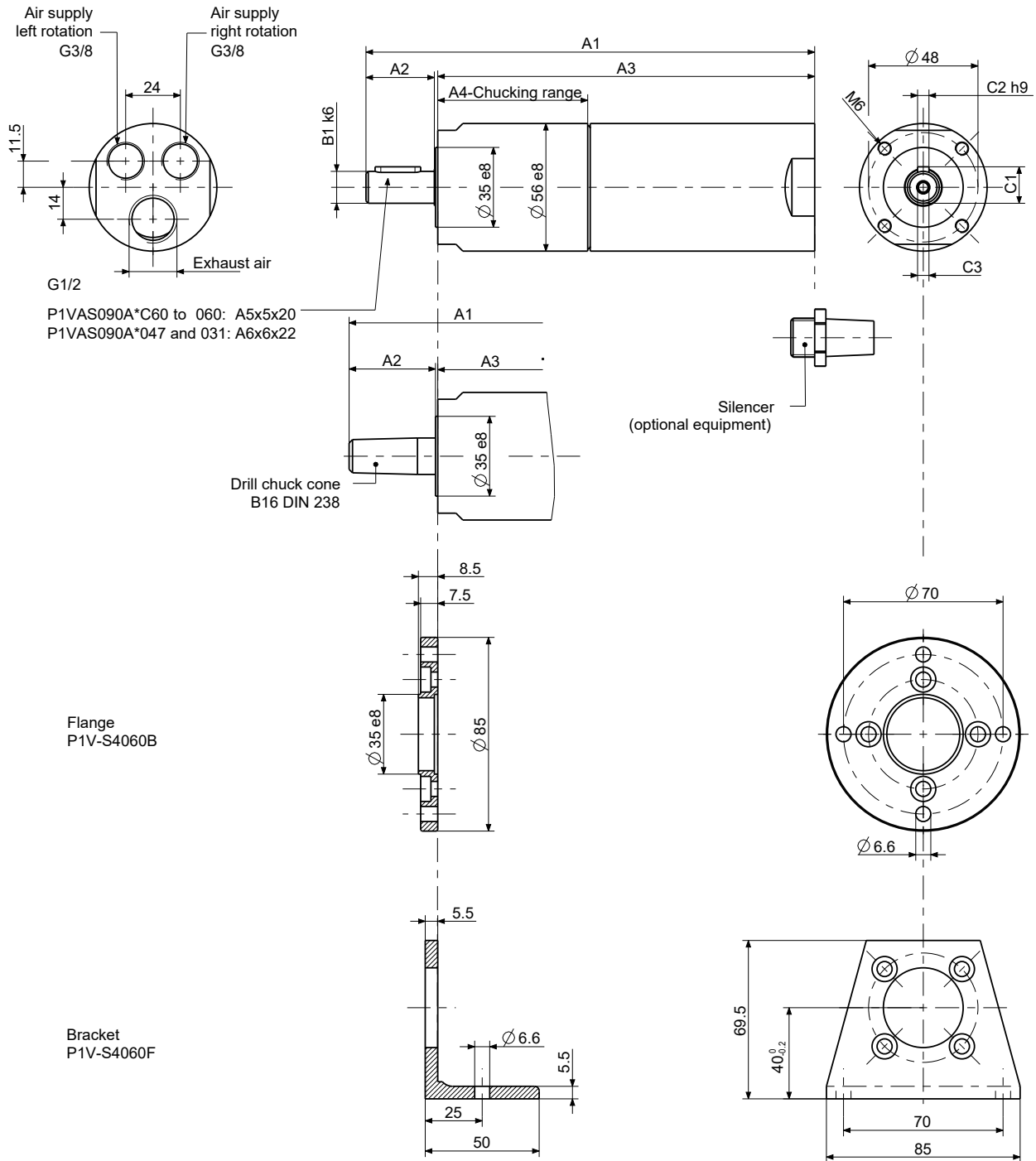

P1VAS090A\*C60 to 060: A5x5x20  
P1VAS090A\*047 and 031: A6x6x22

Drill chuck cone  
B16 DIN 238

Silencer  
(optional equipment)

Flange  
P1V-S4060B

Bracket  
P1V-S4060F

**Dimension [mm] 900 watts**

A1	A2	A3	A4	B1	C1	C2	C3	Part Number			
222	30,5	190,5	66	14	16	5	M5x12	<b>P1VAS090A*C60</b>	<b>P1VAS090A*520</b>	<b>P1VAS090A*367</b>	<b>P1VAS090A*285</b>
240	30,5	208,5	84	14	16	5	M5x12	<b>P1VAS090A*190</b>	<b>P1VAS090A*065</b>		
242	35	205	80,5	19	21,5	6	M6x12	<b>P1VAS090A*047</b>	<b>P1VAS090A*031</b>		

\* 0, C, Z



For inventory, lead times, and kit lookup, visit [www.pdnplu.com](http://www.pdnplu.com)

J22

**Parker Hannifin Corporation**  
Pneumatic Division  
Wadsworth, Ohio  
[www.parker.com/pneumatics](http://www.parker.com/pneumatics)

**1600 watts**  
[mm]

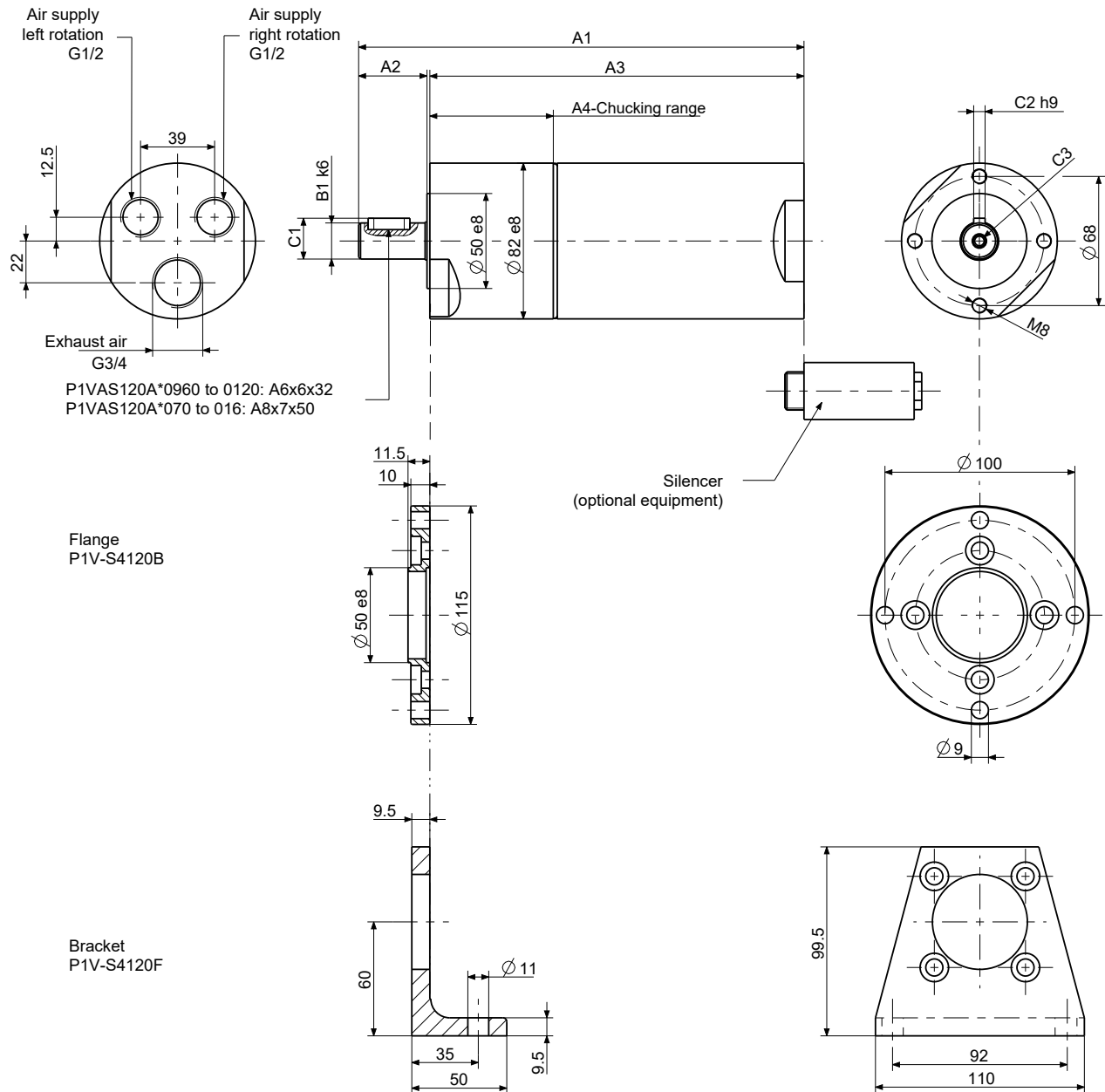

P1VAS120A\*0960 to 0120: A6x6x32  
P1VAS120A\*070 to 016: A8x7x50

Flange  
P1V-S4120B

Bracket  
P1V-S4120F

Silencer  
(optional equipment)

P1VAS  
Stainless Steel

Air Motors

**Dimension [mm] 1600 watts**

A1	A2	A3	A4	B1	C1	C2	C3	Part Number		
235	35	197	65	19	21,5	6	M6x15	<b>P1VAS160A*960</b>	<b>P1VAS160A*250</b>	<b>P1VAS160A*120</b>
268	60	205	73	28	31	8	M10x20	<b>P1VAS160A*070</b>	<b>P1VAS160A*032</b>	<b>P1VAS160A*020</b>
311,5	61,5	248,5	116,5	28	31	8	M10x20	<b>P1VAS160A*016</b>		

\* 0, C, Z, M



For inventory, lead times, and kit lookup, visit [www.pdnplu.com](http://www.pdnplu.com)



**Service kits**

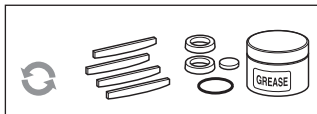

**Optional function "0"**

Service kits, vanes for intermittent lubrication-free operation

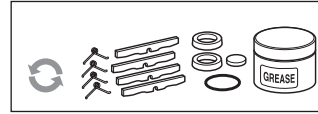
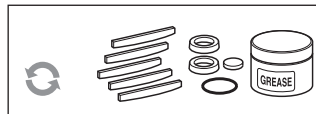

**Optional function "Z"**

Service kits, spring-loaded vanes for intermittent lubrication-free operation

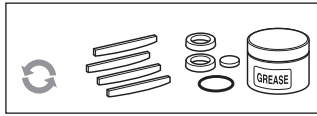
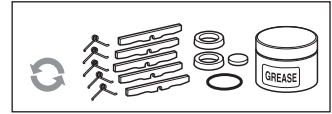

**Optional function "C"**

Service kits, vanes for continuous lubrication-free operation

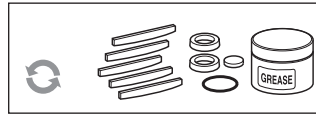

**Lubrication and service life**

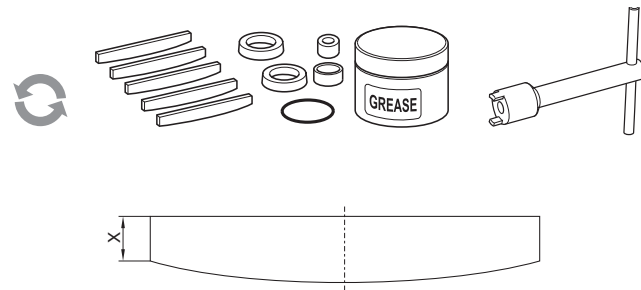

**Dimensions on vanes X (mm), type of vanes**

Air Motor	0	Z	C	M
<b>P1VAS012</b>	3.3	3.3	3.3	3.3
<b>P1VAS020</b>	5.8	5.3	5.3	5.3
<b>P1VAS030</b>	6.0	5.2	6.0	5.2
<b>P1VAS060</b>	6.0	6.0	6.0	6.0
<b>P1VAS090</b>	X	X	X	X
<b>P1VAS160</b>	14.2	13.5	13.5	13.5

The first service is due after approximately 500 hours of operation. After the first service, the service interval is determined by the degree of vane wear\*. The table below shows new dimensions and the minimum dimensions of worn vanes.

The following normal service intervals should be applied to in order to guarantee problem-free operation in air motors working continuously at load speeds.

**Intermittent lubrication-free operation of motors with standard vanes, option 0**

Duty cycle : 70%  
 Max. duration of intermittent use : 15 minutes  
 Filtering 40 µm : 750 hours of operation\*  
 Filtering 5 µm : 1,000 hours of operation\*

**Continuous lubricated operation of motors with standard vanes, option 0**

Duty cycle : Continuous  
 Quantity of oil : 1 drop per m<sup>3</sup> of air  
 Filtering 40 µm : 1,000 hours of operation\*  
 Filtering 5 µm : 2,000 hours of operation\*

**Note! After 1000 hours of operation, the grease in the planetary gearbox must be changed.**

**Continuous lubrication-free operation of motors equipped with vanes, option C**

Duty cycle : Continuous  
 Filtering 40 µm : 750 hours of operation\*  
 Filtering 5 µm : 1,000 hours of operation\*



\* The specified hours of operation apply when the motor is running at the speed corresponding to maximum power (load speed).

This is approximately half free speed. If the motor operates at higher speeds, the service interval is shorter. If the motor operates at lower speeds, the service interval is longer.

P1VAS  
Stainless Steel

Air Motors



For inventory, lead times, and kit lookup, visit [www.pdnplu.com](http://www.pdnplu.com)

**Service Kits**

Vane Option	Air Motor	Part Number
0 vanes option	P1VAS012A0N00	<b>P1VAS6/4455801C</b>
	P1VAS012A0550 to 010	<b>P1VAS6/4455801G</b>
C vanes option	P1VAS012ACN00	<b>P1VAS6/4455801D</b>
	P1VAS012AC550 to 010	<b>P1VAS6/4455801H</b>
Z vanes option	P1VAS012AZN00	<b>P1VAS6/4455804C</b>
	P1VAS012AZ550 to 010	<b>P1VAS6/4455804B</b>
0 vanes option	P1VAS020A0G00	<b>P1VAS6/4447851E</b>
	P1VAS020A0460 to 0005	<b>P1VAS6/4447851F</b>
C vanes option	P1VAS020ACG00	<b>P1VAS6/4447853C</b>
	P1VAS020AC460 to 0005	<b>P1VAS6/4447853B</b>
Z vanes option	P1VAS020AZG00	<b>P1VAS6/4447854C</b>
	P1VAS020AZ460 to 0005	<b>P1VAS6/4447854B</b>
0 vanes option	P1VAS030A0E50	<b>P1VAS6/4447861L</b>
	P1VAS030A0460 to 005	<b>P1VAS6/4447861M</b>
C vanes option	P1VAS030ACE50	<b>P1VAS6/4447863C</b>
	P1VAS030AC460 to 005	<b>P1VAS6/4447863B</b>
Z vanes option	P1VAS030AZE50	<b>P1VAS6/4447864C</b>
	P1VAS030AZ460 to 005	<b>P1VAS6/4447864B</b>
0 vanes option	P1VAS060A0D50 and 550	<b>P1VAS6/4447871K</b>
	P1VAS060A0400 to 070	<b>P1VAS6/4447871M</b>
	P1VAS060A0050 to 018	<b>P1VAS6/4447871L</b>
C vanes option	P1VAS060ACD50 and 550	<b>P1VAS6/4447873E</b>
	P1VAS060AC400 to 070	<b>P1VAS6/4447873C</b>
	P1VAS060AC050 to 018	<b>P1VAS6/4447873D</b>
Z vanes option	P1VAS060AZD50 and 550	<b>P1VAS6/4447874E</b>
	P1VAS060AZ400 to 070	<b>P1VAS6/4447874C</b>
	P1VAS060AZ050 to 018	<b>P1VAS6/4447874D</b>
0 vanes option	P1VAS090A0C60 and 520	<b>P1VAS6/4449191G</b>
	P1VAS090A0367 to 065	<b>P1VAS6/4449191E</b>
	P1VAS090A0047 and 031	<b>P1VAS6/4449191F</b>
C vanes option	P1VAS090ACC60 and 520	<b>P1VAS6/1191563A</b>
	P1VAS090AC367 to 065	<b>P1VAS6/1191563B</b>
	P1VAS090AC047 and 031	<b>P1VAS6/1191563C</b>
Z vanes option	P1VAS090AZC60 and 520	<b>P1VAS6/1191564A</b>
	P1VAS090AZ367 to 065	<b>P1VAS6/1191564B</b>
	P1VAS090AC047 and 031	<b>P1VAS6/1191654C</b>
0 vanes option	P1VAS160A0960 and 250	<b>P1VAS6/4447881E</b>
	P1VAS160A0120 and 070	<b>P1VAS6/4447881F</b>
	P1VAS160A0032 and 020	<b>P1VAS6/4447881C</b>
	P1VAS160A0016	<b>P1VAS6/4447881D</b>
C vanes option	P1VAS160AC960 and 250	<b>P1VAS6/4447883E</b>
	P1VAS160AC120 and 070	<b>P1VAS6/4447883F</b>
	P1VAS160AC032 and 020	<b>P1VAS6/4447883C</b>
	P1VAS160AC0016	<b>P1VAS6/4447883D</b>
Z vanes option	P1VAS160AZ960 and 250	<b>P1VAS6/4447884E</b>
	P1VAS160AZ120 and 070	<b>P1VAS6/4447884F</b>
	P1VAS160AZ032 and 020	<b>P1VAS6/4447884C</b>
	P1VAS160AZ016	<b>P1VAS6/4447884D</b>

P1VAS  
 Stainless Steel

Air Motors



For inventory, lead times, and kit lookup, visit [www.pdnplu.com](http://www.pdnplu.com)

Model Code

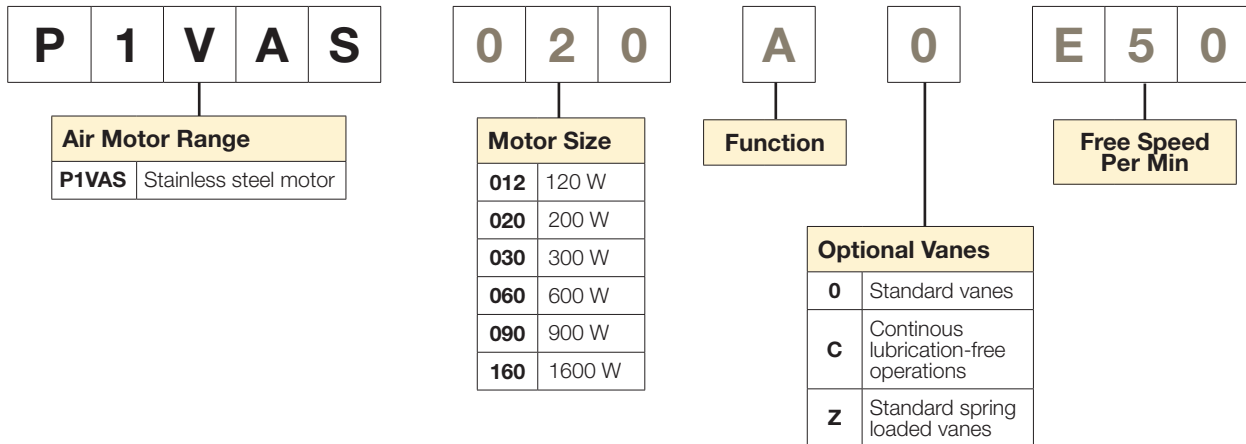

This model code can not be used for creating new part numbers except for optional vanes. All possible combinations between motor size, function and free speed are in the previous pages.

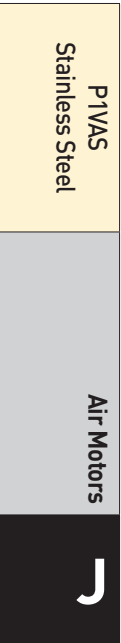



## Actuator Accessories

### Linear Alignment Couplers

Technical Data	K2
----------------	----

### Flow Controls

Brass Flow Controls	K3
---------------------	----

### PRL Series – Stand Alone Rod-Lock

Features	K4
Ordering Information	K4
Technical Data	K5

## Linear Alignment Couplers

Linear Alignment Couplers are available in 8 standard thread sizes...

**Cost Saving Features and Benefits Include...**

- Maximum reliability for trouble-free operation, long life and lower operating costs
- Increased cylinder life by reducing wear on piston and rod bearings
- Stainless steel versions available. Please consult factory.
- Simplifying cylinder installation and reducing assembly costs
- Increase rod bearing and rod seal life for lower maintenance costs

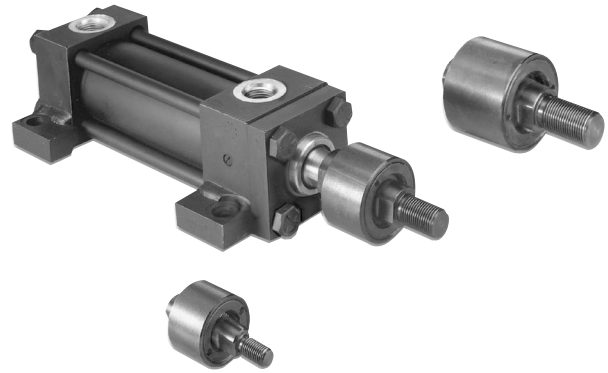

### Alignment coupler

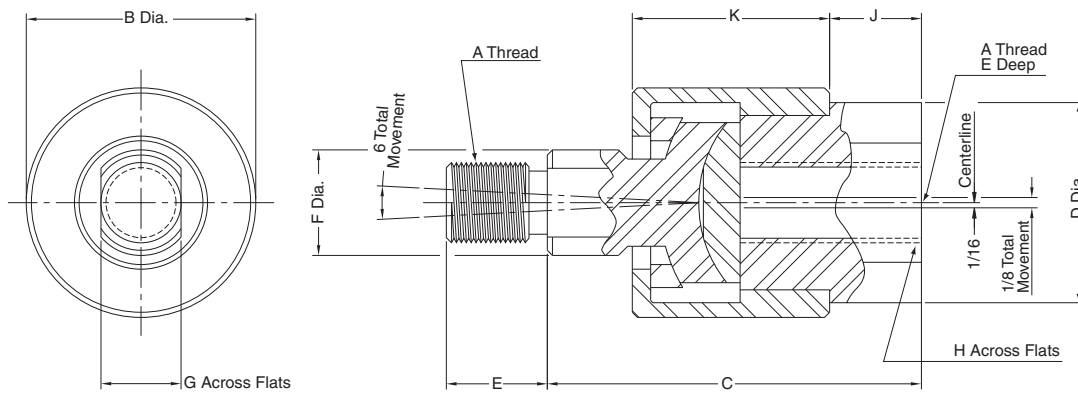

### Part numbers and dimensions

A	B	C	D	E	F	G	H	J	K	Max. Pull Load (lbs.)	Approx. Weight (Lbs.)	Part Number
5/16 -24	1-1/8	1-3/4	15/16	1/2	1/2	3/8	3/4	3/8	15/16	1200	0.35	1347570031
3/8 -24	1-1/8	1-3/4	15/16	1/2	1/2	3/8	3/4	3/8	15/16	2425	0.35	1347570038
7/16 -20	1-3/8	2	1-1/8	3/4	5/8	1/2	7/8	3/8	1-3/32	3250	0.55	1347570044
1/2 -20	1-3/8	2	1-1/8	3/4	5/8	1/2	7/8	3/8	1-3/32	4450	0.55	1347570050
5/8 -18	1-3/8	2	1-1/8	3/4	5/8	1/2	7/8	3/8	1-3/32	6800	0.55	1347570063
3/4 -16	2	2-5/16	1-5/8	1-1/8	1-5/16	3/4	1-5/16	7/16	1-9/32	9050	1.4	1347570075
7/8 -14	2	2-5/16	1-5/8	1-1/8	1-5/16	3/4	1-5/16	7/16	1-9/32	14450	1.4	1347570088
1-14	3-1/8	3	2-3/8	1-5/8	1-7/16	1-1/4	1-7/8	3/4	1-25/32	19425	4.8	1347570100

### How to order linear alignment couplers

When ordering a cylinder with a threaded male rod end, specify the coupler of equal thread size by part number as listed in Table 1, i.e.; Piston Rod "KK" or "CC" dimension is 3/4" - 16", specify coupler part number 1347570075.

Linear Alignment  
Flow Controls  
4TK Series  
PRL Series  
Actuator Accessories  
**K**



For inventory, lead times, and kit lookup, visit [www.pdnplu.com](http://www.pdnplu.com)

**Brass Right Angle Flow Controls**

The Right Angle Flow Control is an ideal solution to cylinder speed control where space is at a premium. Costly fittings, connections and piping expenses can be eliminated because the valve can rotate 360°, the piping alignment can be in any direction. It then locks into place. The 1/8" model can be rotated after final assembly.

Install by threading male end directly into cylinder port. The free-flow and metered-flow direction is automatically predetermined. Free-flow direction is into cylinder and metered-flow is out of the cylinder. Flow is adjusted with an Allen wrench and locked with nut.

Right Angle Flow Control also available with Prestolok fittings on inlet port to accommodate 5/32 - 3/8 tube sizes. This allows for quick connection and eliminates need for separate tube fitting.

**Specifications**

- Body: Brass
- Plunger: Brass and Acetal
- Seals: Buna N
- Temperature Range: 0°F to 140°F (-18°C to 60°C)
- Pressure Rating: 125 PSIG (8.6 bar) max.

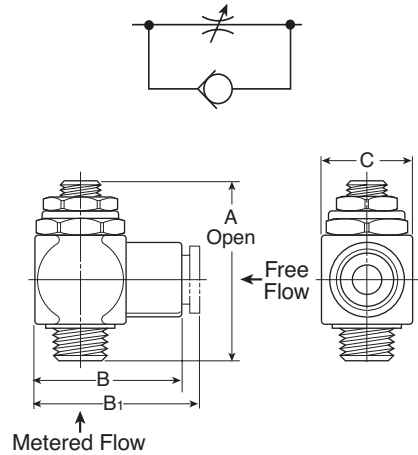
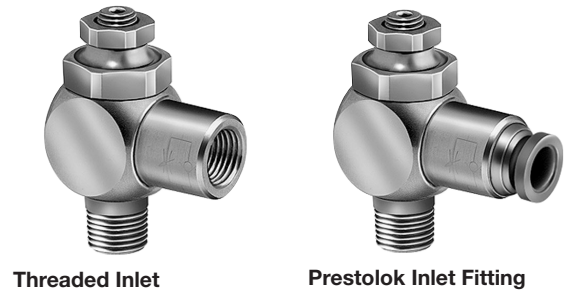

**Model Selection and Dimensions**

**Threaded Inlet**

Male Thread (NPT)	Female Thread (NPT)	A Inch (mm)	B Inch (mm)	C Inch (mm)	Weight oz. (kg)	Cv		Part Number
						Adjusted Flow	Free Flow	
1/8	1/8	1.74 (44)	1.18 (30)	.67 (17)	2.0 (0.9)	0.26	0.20	032510125
1/4	1/4	1.99 (51)	1.40 (36)	.91 (23)	4.5 (2.0)	0.75	0.68	032510250
3/8	3/8	2.28 (58)	1.71 (43)	1.06 (27)	7.0 (3.2)	0.84	0.72	032510375
1/2	1/2	2.69 (68)	1.98 (53)	1.26 (32)	11.0 (5.0)	1.64	1.41	032510500

**With Prestolok Fittings**

Thread (NPT)	Tube Size (OD)	A Inch (mm)	B1 Inch (mm)	C Inch (mm)	Weight oz. (kg)	Cv		Part Number
						Adjusted Flow	Free Flow	
1/8	5/32	1.74 (44)	1.18 (30)	.67 (17)	2.0 (0.9)	0.19	0.16	032511215
1/8	1/4	1.74 (44)	1.18 (30)	.67 (17)	2.0 (0.9)	0.28	0.22	032511225
1/4	1/4	1.99 (51)	1.40 (36)	.91 (23)	4.5 (2.0)	0.51	0.44	032512525
1/4	3/8	1.99 (51)	1.40 (36)	.91 (23)	4.5 (2.0)	0.62	0.53	032512538
3/8	3/8	2.28 (58)	1.71 (43)	1.06 (27)	7.0 (3.2)	0.78	0.65	032513838

**CAUTION:** If it is possible that the ambient temperature may fall below freezing, the medium must be moisture-free to prevent internal damage or unpredictable behavior.

Linear Alignment

Flow Controls

4TK Series

PRL Series

Actuator Accessories

**K**



For inventory, lead times, and kit lookup, visit [www.pdnplu.com](http://www.pdnplu.com)

## PRL Series

The PRL Series rod lock is used in applications where the locking of linear travel is required. It is commonly used in work holding applications and for locking tools and fixtures in the event of air pressure or electrical control failure.

### Application

- **Clamping:** Without an appropriate air signal to the rod lock pressure port, the rod lock clamps to the precision metric rod and prevents rod movement in the axial direction.
- **Delatching:** When 4 Bar (58 PSIG) of air pressure is applied to the port, the rod lock releases and allows free movement of the rod. This will be required for installation.
- **Locking Direction:** The rod lock is designed specifically to prevent rod movement in the axial direction only. It is not recommended for locking rotary rod motion.
- **Rod Material:** The Series PRL rod lock is a precision locking device, therefore strict rod tolerances and rod material specifications are required to ensure safe and proper operation. Minimum requirements for the rod material include a chrome plated surface finish of 10 micro inches or less and a surface hardness of 52 Rc. Rod material may be ordered separately in custom lengths. See next page for how to order.
- **Environment:** The rod lock is recommended for use in dry, clean conditions. Please take precautions to prevent moisture from entering the pressure port or the exhaust port of the locking device.

There should be no relative motion between the rod and the Rod Lock Device when the locking device is activated. The locking device is not intended to brake a movement in repeated sequences.

### Considerations for Rod Sizing

When applying a rod lock device, it is important to consider the loading forces which will be imposed on the rod in the axial direction.

For applications where the rod lock and its associated load impose a compressive force on the rod, please consider the axial compression force and rod length to select the appropriate rod diameter for preventing rod buckling.

In situations where the rod lock and its associated load place the rod in tension, please take care to securely fasten the rod ends to the machine member.

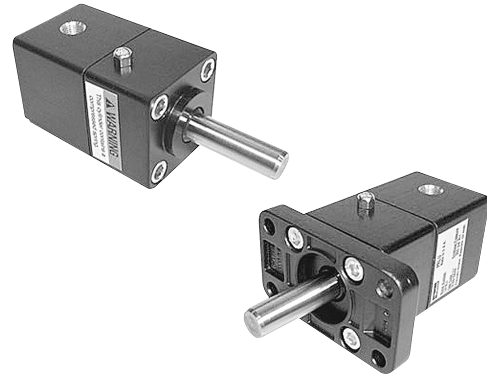

### Operating information

Working pressure	Max. 10 bar (145 PSIG)
Working temperature	-20° to 80°C (-4°F to 176°F)
Locking pressure	4 bar (58 PSIG) ±10%
Filtration requirements	40 micron, dry filtered air

### Holding Forces

Model Number	Holding force	
	Pounds (lbs.)	Newtons (N)
16PRL*	193	860
20PRL*	481	2140
25PRL*	1211	5390
32PRL*	1894	8425

\* Character reserved for port style

### Ordering information

<b>25</b>	<b>PRL</b>	<b>U</b>	
<b>Rod Diameter</b>		<b>Ports</b>	<b>S</b> <b>Specials</b>
Specify 16, 20, 25 or 32 (mm)		<b>U</b> NPTF <b>R</b> BSPP	Leave blank if no specials



For inventory, lead times, and kit lookup, visit [www.pdnplu.com](http://www.pdnplu.com)

Linear Alignment  
 Flow Controls  
 4TK Series  
 PRL Series  
 Actuator Accessories  
**K**



**Basic rod lock**

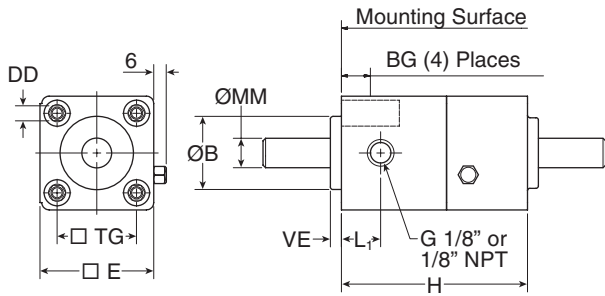

**Rod lock with flange mount**

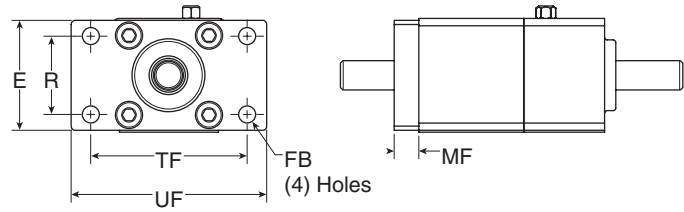

**Mounting dimensions**

Part	Rod dia. MM	B D11	BG	DD	E	FB	H	L1	MF	R	TF	TG	UF	VE
16PRL*	16.00 (-.04)	35	16	M6	51	9	81.1	16	10	36	72	38	92	4.5
20PRL*	20.00 (-.04)	45	16	M8	76	9	100.8	26	12	50	100	56.5	129	5
25PRL*	25.00 (-.04)	55	16	M10	114.5	14	146	50	16	75	150	89	186	4
32PRL*	32.00 (-.04)	60	20	M12	140	16	165.2	60	20	90	180	110	220	6

\* Character reserved for port style

**Flange mounting kit**

Mounting kits are available separately from the rod lock device. Please use the following part numbers to order. Mounting fasteners are included with the kits.

Model Number	Flange Mount
16PRL*	P1C-4LMB
20PRL*	P1C-4NMB
25PRL*	P1C-4QMB
32PRL*	P1C-4RMB

\* Character reserved for port style

**Metric rod material**

Rods will be supplied in the specified length with chamfered ends. Please note, the rod material is case hardened and requires annealing prior to machining. Parker is pleased to quote custom machined rods per customer supplied drawings.



**Caution:** Using piston rod material which does not meet the tolerance and finished conditions as listed on the previous page may prevent the locking device from properly holding the intended load.

**How to Order**

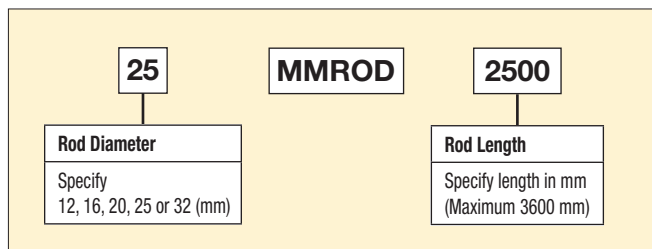



For inventory, lead times, and kit lookup, visit [www.pdnplu.com](http://www.pdnplu.com)

K6

**Parker Hannifin Corporation**  
Pneumatic Division  
Wadsworth, Ohio  
[www.parker.com/pneumatics](http://www.parker.com/pneumatics)



## P8S Sensors

### Electronic and Reed Sensors

Product Overview	L2
Technical Data	L3
Dimensions	L4
Connection Type and Diagram	L5
Ordering Information	L6

### Continuous Position Sensors

Product Overview	L7
Technical Data	L8
Dimensions	L9
Connection Type and Diagram	L9
Ordering Information	L9

### Accessories

Mounting and Brackets	L10
Connectors and Cables	L11

### Pneumatic Sensor for Tie Rod Cylinders

Product Overview	L12
Technical Data	L12
Dimensions	L12



## P8S Electronic and Reed Sensors

The P8S Series magnetic cylinder sensor enables quick, precise and contactless sensing of the piston's position in cylinders. It is easy to mount, can be used in numerous applications and offers an outstanding price-performance ratio.

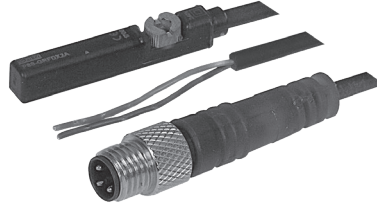

Electronic and  
Reed Sensors

Continuous  
Position Sensor

### Product Overview

As the term magnetic switch suggests, these are operated by magnetic fields; another description widely used is magnetic "SENSOR". As our eyes sense change of light, our ears sense the change of sound, magnetic sensors / switches sense the change of magnetic flux in pneumatic and hydraulic cylinders. When magnetic sensors sense a magnetic field it will give a switching signal, through a control circuit, allowing sensing or control operation to be achieved.

Because of the characteristics of magnetic sensors they can sense a change of magnetic field relative to the position of the magnet, such as in a pneumatic or hydraulic cylinder, whereby the magnet is attached to a moving piston and thus the position of the moving part (ie Piston) can be detected.

The magnet is mounted on the piston of the cylinder and thus moves with the piston.

The magnetic sensor (switch) is fixed either directly to the cylinder or with an additional mounting bracket. When the piston (magnet) moves to the position under a magnetic sensor, the switch will operate due to the change of the magnetic field and give a switching signal.

Thus the position of the piston can be identified and a resulting signal generated to continue the sequence of a circuit.

Magnetic sensors available can be classified into two different groups, they are sensors with contacts which are called mechanically operated or reed sensors and the other type is sensors without contacts and are called solid state type or electronic.

Parker P8S Series sensors are suitable for use with a large range of actuators. They can either be inserted directly into the cylinder tube extrusion or mounted using additional brackets. For direct mounting the sensor is positioned within the cylinder sensor groove, offering mechanical protection, then securely clamped into position by a simple turn of a screw. For other cylinder versions there are a number of optional sensors brackets that clamp to the cylinder and offer other mounting positions.

For easy installation there are several cable lengths available with either M8 connector or flying lead. The electronic sensors are "Solid State", i.e. they have no moving parts. They are provided with short-circuit protection and transient protection as standard. The built-in electronics make the sensors suitable for applications with high on and off switching frequency where long service life is required.

Please note that for low temperature applications sensors are normally specified for full performance down to -30°C only. High temperature cylinders do not have a magnetic piston and therefore cannot be used with sensors.

Accessories

Sensor for  
The Rod Cylinder

Electronic  
Sensors

**Technical Data** - Square body design, insert straight in T-slot, screw 1/4 turn

	<b>Electronic PNP   NPN</b>	<b>Electric Reed</b>
Cylinder type:	Profile with T-slot	
Cylinder type with adapter:	Profile with S-slot (dovetail)   Tie rods   Round cylinders	
Installation:	Quarter turn, fixed by allen key 2.5 mm or flathead screwdriver	
Housing length:	29.5 mm	29.5 mm 5 - 30 V AC/DC
	24 mm (NAMUR ATEX)	29.5 mm 5 - 120 V AC/DC 32.5 mm 5 - 230 V AC/DC
Output Type:	PNP   NPN	Reed
Switching (on/off) switching frequency:	± 1,000 Hz	± 400 Hz
Output Function:	Normally Open (NO)   Normally Closed (NC) 3-wire	Normally Open (NO)   Normally Closed (NC) 2-wire Normally Open (NO) 3-wire
Enclosure rating:	IP67	
Supply Voltage:	IP67 (NAMUR ATEX) 10 to 30 V DC	
	8.2 to 20 V DC (NAMUR 1GD)   10 to 26 V DC (ATEX 3GD)	5 to 30   5 to 120   5 to 230 V AC/DC 2-wire, 3-wire depending on type
Power consumption:	<= 8 mA	-
	<= 10 mA (NAMUR, ATEX)	-
Voltage drop:	<= 2 V	<= 3.5 V 2-wire   <= 0.1 V 3-wire
	<= 2.2 V (NAMUR, ATEX)	-
Continuous output current I <sub>a</sub> :	<= 100 mA	<= 100 mA 3-wire
	<= 60 mA (NAMUR)   <= 50 mA (ATEX)	<= 500 mA (DC)   <= 300 mA (AC)
Switching capacity:	-	<= 6 W
Protection class:	III	III   II 2-wire depending on type III 3-wire
	2.6 to 3.3 mT	2.1 to 3.4 mT
Response sensitivity:	2.8 mT (NAMUR, ATEX)	-
Overrun distance:	10 mm	
	9 mm (NAMUR, ATEX)	-
Hysteresis:	<= 0.8 mT	-
	<= 0.5 mT (NAMUR, ATEX)	-
Repeatability:	<= 0.1 mT	
Reverse polarity protection:	Yes	No 2-wire
	-	Yes 3-wire
Short circuit protection:	Yes	-
Power-up pulse protection:	Yes (NAMUR, ATEX)	-
Ambient operating temperature range:	-30 to +80 °C (PUR cable)   -30 to +70°C (PVC cable)	
	-25 to +80 °C (NAMUR 1GD)   -20 to +50°C (ATEX 3GD)	
Shock and vibration resistance:	30 g 11 ms / 10 ... 55 Hz, 1 mm	
EMC:	According to EN 60947-5-2	
International standard:	CE   C UL US   RoHs   Ex   IEC   IEC Ex	
Housing material:	Plastic polyamid PA12	
Screw material:	Stainless steel	
Cable material:	PUR (Polyurethane)   PVC (Polyvinyl Chloride)	
Conductor cross-section:	0.14 mm <sup>2</sup>   0,12 mm <sup>2</sup> depending on type 0.14 mm <sup>2</sup> (NAMUR, ATEX)	
Indication LED color:	Yellow, no LED reed NC	
Connector:	M8R (knurled nuts)   None (Flying lead)	

Electronic and  
Reed Sensors

Continuous  
Position Sensor

Accessories

Sensor for  
Tie Rod Cylinder

Electronic  
Sensors



For inventory, lead times, and kit lookup, visit [www.pdnplu.com](http://www.pdnplu.com)

**Dimensions, mm (inch)**

**PNP, NPN Output 10 to 30 V DC**

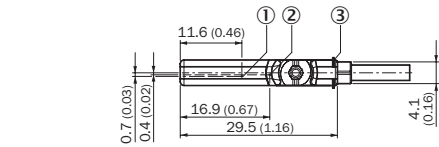
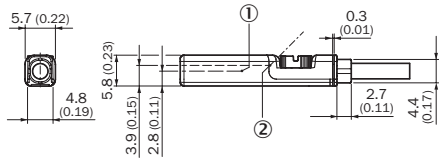

- ① Position sensor element
- ② Indication LED
- ③ Retaining ribs

**Reed Output 5 to 230 V AC/DC**

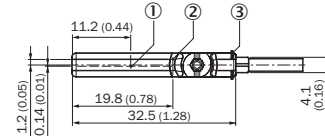
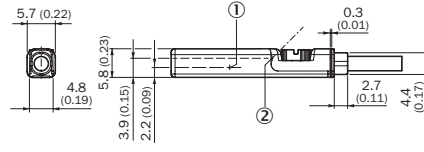

- ① Position sensor element
- ② Indication LED
- ③ Retaining ribs

**Reed Output 5 to 30 V AC/DC**

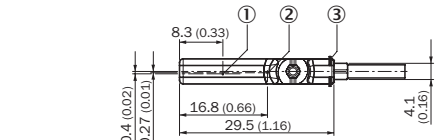
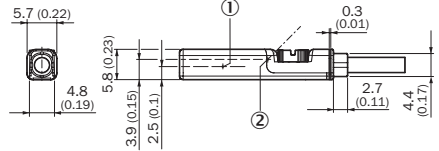

- ① Position sensor element
- ② Indication LED
- ③ Retaining ribs

**Reed Output 5 to 120 V AC/DC**

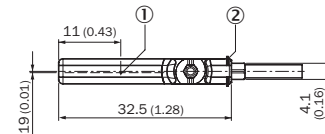
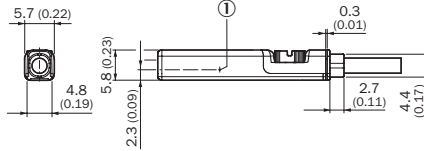

- ① Position sensor element
- ② Retaining ribs

**NAMUR ATEX 1G, 1D, ATEX 3G, 3D**

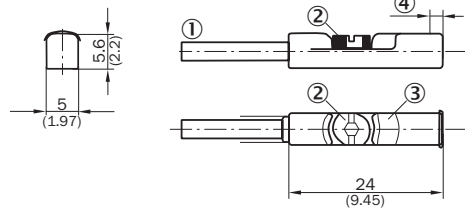

- ① Connection
- ② Fixing screw
- ③ Indication LED
- ④ Position of sensor element; short overrun distance: 2 mm; long overrun distance: 1.7 mm

**Connector M8R**

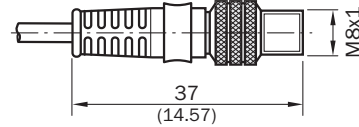

**Installation**

Square body design, Insert straight in T-slot, screw 1/4 turn

**With Adapter in S-Dovetail Slot**

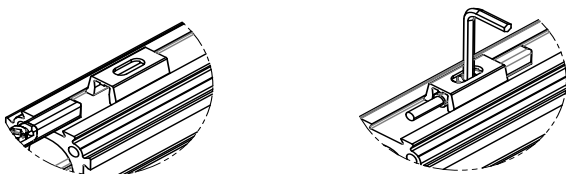

Note:  
The adapter is delivered with each sensor.

**Without Adapter directly in T-Slot**

Put-in straight

Screw 1/4 turn

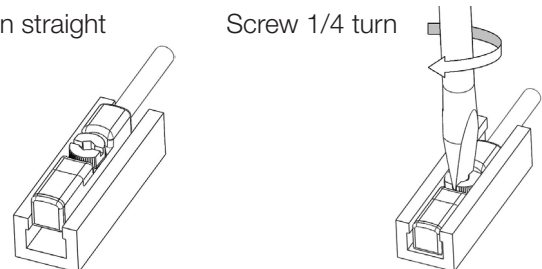

**Connection Type and Diagram**

**PNP NO**

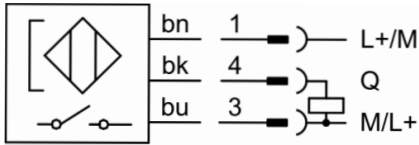

**PNP NC**

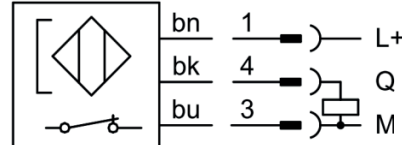

**NPN NO**

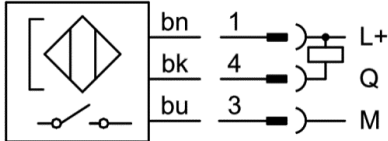

**NPN NC**

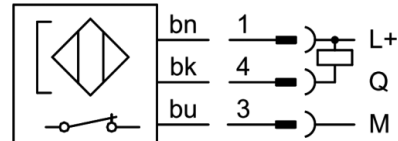

**Reed NO 3-wire**

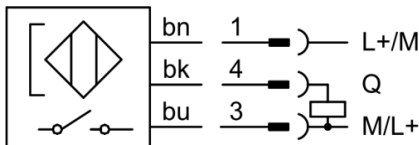

bn: brown  
 bk: black  
 bu: blue  
 Q: load  
 M: Mass  
 L+: Power

**Reed NO 2-wire**

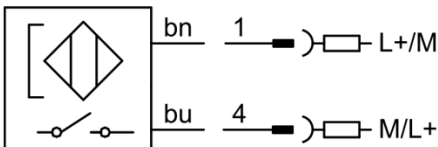

**Reed NC 2-wire**

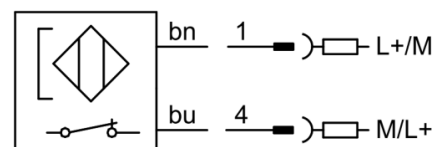

**NAMUR NO ATEX 1G, 1D**

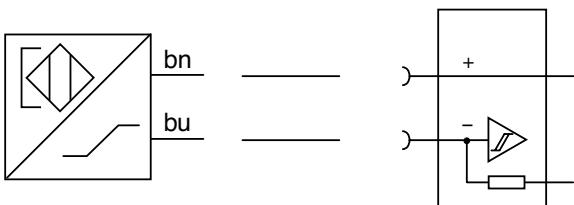

**PNP NO ATEX 3G, 3D**

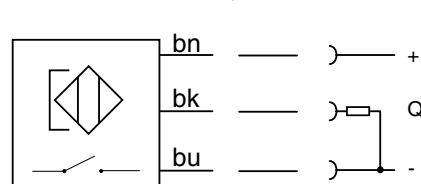

**Pin assignment, M8 with knurled nut**

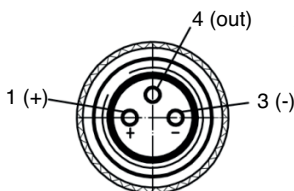

**Flying leads**

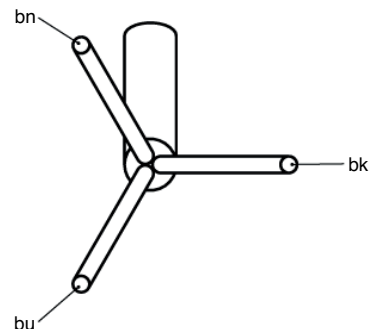

Electronic and  
 Reed Sensors

Continuous  
 Position Sensor

Accessories

Sensor for  
 Tie Rod Cylinder

Electronic  
 Sensors



## Square body design, insert straight in T-slot, screw 1/4 turn

	<b>NPN NORMALLY CLOSED</b>	<b>VOLTAGE</b>	<b>CONNECTION</b>	<b>CABLE</b>	<b>Part Number</b>
	NPN-NC, with LED, 3-wire	10-30 V DC	3 m Flying Lead	PUR IP67	P8SAGMFAX
	NPN-NC, with LED, 3-wire	10-30 V DC	10 m Flying Lead	PUR IP67	P8SAGMFDX
	NPN-NC, with LED, 3-wire	10-30 V DC	0.3 m M8	PUR IP67	P8SAGMCHX
	<b>NPN NORMALLY OPEN</b>	<b>VOLTAGE</b>	<b>CONNECTION</b>	<b>CABLE</b>	<b>Part Number</b>
	NPN-NO, with LED, 3-wire	10-30 V DC	3 m Flying Lead	PUR IP67	P8SAGNFAX
	NPN-NO, with LED, 3-wire	10-30 V DC	10 m Flying Lead	PUR IP67	P8SAGNFDX
	NPN-NO, with LED, 3-wire	10-30 V DC	0.3 m M8	PUR IP67	P8SAGNCHX
	<b>PNP NORMALLY CLOSED</b>	<b>VOLTAGE</b>	<b>CONNECTION</b>	<b>CABLE</b>	<b>Part Number</b>
	PNP-NC, with LED, 3-wire	10-30 V DC	3 m Flying Lead	PUR IP67	P8SAGQFAX
	PNP-NC, with LED, 3-wire	10-30 V DC	3 m Flying Lead	PVC IP67	P8SAGQFLX
	PNP-NC, with LED, 3-wire	10-30 V DC	10 m Flying Lead	PUR IP67	P8SAGQFDX
	PNP-NC, with LED, 3-wire	10-30 V DC	0.3 m M8	PUR IP67	P8SAGQCHX
	<b>PNP NORMALLY OPEN</b>	<b>VOLTAGE</b>	<b>CONNECTION</b>	<b>CABLE</b>	<b>Part Number</b>
	PNP-NO, with LED, 3-wire	10-30 V DC	3 m Flying Lead	PUR IP67	P8SAGPFAX
	PNP-NO, with LED, 3-wire	10-30 V DC	3 m Flying Lead	PVC IP67	P8SAGPFLX
	PNP-NO, with LED, 3-wire	10-30 V DC	10 m Flying Lead	PUR IP67	P8SAGPFDX
	PNP-NO, with LED, 3-wire	10-30 V DC	10 m Flying Lead	PVC IP67	P8SAGPFTX
	PNP-NO, with LED, 3-wire	10-30 V DC	0.3 m M8	PUR IP67	P8SAGPCHX
	<b>REED NORMALLY CLOSED</b>	<b>VOLTAGE</b>	<b>CONNECTION</b>	<b>CABLE</b>	<b>Part Number</b>
	Reed-NC, No LED, 2 wire	10-30 V AC/DC	10 m Flying Lead	PUR IP67	P8SAGEFRX
	Reed-NC, No LED, 2-wire	10-120 V AC/DC	10 m Flying Lead	PUR IP67	P8SAGEFRX1
	Reed-NC, No LED, 2-wire	10-30 V AC/DC	0.3 m M8	PUR IP67	P8SAGECNX
	<b>REED NORMALLY OPEN</b>	<b>VOLTAGE</b>	<b>CONNECTION</b>	<b>CABLE</b>	<b>Part Number</b>
	Reed-NO, with LED, 2-wire	10-30 V AC/DC	3 m Flying Lead	PUR IP67	P8SAGRFAFX
	Reed-NO, with LED, 2-wire	10-120 V AC/DC	3 m Flying Lead	PVC IP67	P8SAGRFLX1
	Reed-NO, with LED, 2-wire	10-240 V AC/DC	3 m Flying Lead	PVC IP67	P8SAGRFLX2
	Reed-NO, with LED, 2-wire	10-240 V AC/DC	10 m Flying Lead	PUR IP67	P8SAGRFDX2
	Reed-NO, with LED, 2-wire	10-120 V AC/DC	10 m Flying Lead	PVC IP67	P8SAGRFTX1
	Reed-NO, with LED, 2-wire	10-30 V AC/DC	0.3 m M8	PUR IP67	P8SAGRCHX
	<b>REED NORMALLY OPEN</b>	<b>VOLTAGE</b>	<b>CONNECTION</b>	<b>CABLE</b>	<b>Part Number</b>
	Reed-NO, with LED, 3-wire	10-30 V AC/DC	3 m Flying Lead	PUR IP67	P8SAGSFAX
	Reed-NO, with LED, 3-wire	10-30 V AC/DC	3 m Flying Lead	PVC IP67	P8SAGSFLX
	Reed-NO, with LED, 3-wire	10-30 V AC/DC	10 m Flying Lead	PUR IP67	P8SAGSFDX
	Reed-NO, with LED, 3-wire	10-30 V AC/DC	10 m Flying Lead	PVC IP67	P8SAGSFTX
	Reed-NO, with LED, 3-wire	10-30 V AC/DC	0.3 m M8	PUR IP67	P8SAGSCHX
	<b>ATEX IP67</b>	<b>VOLTAGE</b>	<b>CONNECTION</b>	<b>CABLE</b>	<b>Order Code</b>
	PNP-NO, with LED, 3-wire	10-26 V DC	3 m Flying lead	PUR IP67	P8SAGPFAXS
	NAMUR-NO, with LED, 2-wire	8.2-20 V DC	5 m Flying Lead	PVC IP67	P8SAGDFMXW *
	NAMUR-NO, with LED, 2-wire	8.2-20 V DC	10 m Flying Lead	PVC IP67	P8SAGDFTXW *

**Note:**

-30 to +80 °C (PUR cable) | -30 to +70 °C (PVC cable) | -25 to +80 °C (NAMUR 1GD) | -20 to +50 °C (ATEX 3GD)

All sensors come with an adapter for S-dovetail Parker type OSP grooves.

\* with an aluminium adapter

For inventory, lead times, and kit lookup, visit [www.pdnplu.com](http://www.pdnplu.com)

## P8S Continuous Position Sensors

Many applications require more than just end of stroke sensing of an actuator, but traditional methods of continuous sensing are expensive to implement. Parker's CPS (Continuous Position Sensor) enables quick, precise and contactless continuous position sensing of a magnetic piston.

CPS sensors continuously supply data via analog outputs or IO-Link. Analog position sensors have a voltage output of 0 V ... 10 V as well as a current output of 4 mA ... 20 mA. CPS enables flexible machine concepts, making it possible to solve tasks in areas such as quality monitoring and process control in conjunction with pneumatic cylinders. This continuous transfer of position data upgrades the functionality of the pneumatic cylinders by making them more intelligent, and as a result, more versatile. CPS settings can be adjusted during or after installation using a teach button or using IO-Link.

CPS can be mounted directly in standard T-slots without the need for additional accessories. Mounting on other cylinder types, (round, tie rod) is possible with adapters.

- Continuous position sensing
- IO-Link communication with M12 connector
- No modification to the actuator
- Analog version with M8 connector
- 5 sizes with sensing ranges from 32 mm to 256 mm
- IP67 design suitable for any industrial application
- Yellow teach button for easy set-up

### Technical specification:

- 1 ms sampling rate
- 0.03% full scale resolution
- 0.06% full scale repeatability
- 0.3 mm Linearity error

### How it works:

The CPS product detects the position of an actuator via the magnet on the piston. The sensor settings can easily be adjusted during installation using the yellow teach button or during operation over the IO-Link communication. This upgrades the functionality of the pneumatic actuator by making it more intelligent and versatile in support of the Industry 4.0 initiative.

### How it connects:

Analog version has a M8 connector and a voltage output of 0-10V as well as a current output of 4-20mA. IO-Link version has a M12 connector and transmits position via 2 bytes of process input data and also allows for parameter control of measuring range and locking of the teach button. It can be controlled by Class A or Class B IO-Link Masters.



### How it installs:

The Parker CPS requires the use of a magnetic piston. The product will fit T-slot cylinders without any additional mounting hardware.

### Without Adapter:

Direct drop-in T-slot  
 T-slot dimensions [mm ± 0.1]

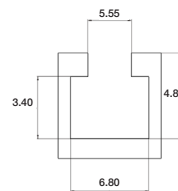

- 1) Pivot sensor into the slot
- 2) Teach the CPS unit the desired measuring range
- 3) Tighten set screws

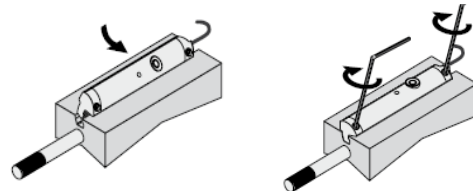

Electronic and  
 Reed Sensors

Continuous  
 Position Sensor

Accessories

Sensor for  
 Tie Rod Cylinder

Electronic  
 Sensors

## Technical Data

Cylinder type:	Profile with T-slot
Installation:	Drop in, fixed by allen key 1.5 mm
Measuring range:	32 to 256 mm depending on type <sup>1)</sup>
Housing length:	45 to 269 mm depending on type
Output Function:	Analog   IO-Link
Analog output (voltage):	0 to 10 V   -
Analog output (current):	4 to 20 mA   -
Teach-in:	Yes
Enclosure rating:	IP 67 (according to EN 60529)
Supply Voltage: <sup>2)</sup>	15 to 30 V DC
Power consumption: <sup>3)</sup>	<= 22 mA (analog)   <= 25 ma (IO-Link)
Max load resistance: <sup>4)</sup>	<= 500 Ω
Min load resistance: <sup>5)</sup>	<= 2 kΩ
Protection class:	III
Time delay before availability:	1.5 s
Required magnetic field sensitivity:	3 mT / 2 mT (analog)   3 mT (IO-Link)
Resolution: <sup>6)</sup>	0.03% full scale range (max >=0.05 mm)
Linearity error: <sup>7)</sup>	0.3 mm
Repeat accuracy: <sup>8)</sup>	0.06% full scale range (>= 0.1 mm)
Sampling rate: <sup>9)</sup>	1 ms
Indication LED color:	Yellow (analog)
Reserve polarity protection:	Yes (analog)
Short circuit protection:	Yes (analog)
Ambient operating temperature range:	-20 to +70 °C (PUR cable)
Shock and vibration resistance:	30 g 11 ms / 10 ... 55 Hz, 1 mm
EMC: <sup>10)</sup>	According to EN 60947-5-2
International standard:	CE   C UL US   CCC (not applicable)   RoHs   IO-Link
UL file No:	On request
Housing material:	Plastic polyamid PA12
Screw material:	Stainless steel
Cable material:	PUR (Polyurethane)
Conductor cross-section:	0.08 mm <sup>2</sup>
Connector:	M12 (IO-Link) or M8 (analog)



<sup>1)</sup> ± 1 mm

<sup>2)</sup> Reverse-polarity protected, operation in short-circuit protected network: max. 8 A.

<sup>3)</sup> Without load

<sup>4)</sup> Power output, at 24 V

<sup>5)</sup> Voltage output

<sup>6)</sup> FSR: Full Scale Range; max. measuring range.

<sup>7)</sup> At 25°C, linearity error (maximum deviation) depending on response curve and minimal deviation function.

<sup>8)</sup> At 25°C, repeatability magnet movement in one direction.

<sup>9)</sup> Only in standard mode, not in IO-Link mode.

<sup>10)</sup> The analogue measured value can deviate under transient conditions.

**Dimensions, mm (inch)**

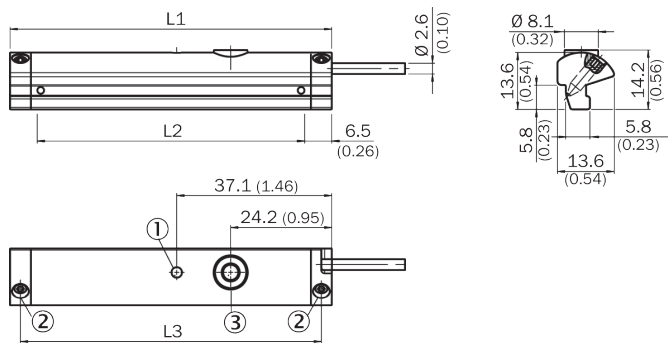

- ① Function indicator
- ② Fixing screw
- ③ Teach-in button

Part Number				
L1	L2 *	L3	Analog	IO-Link
45	32	40	<b>P8SAGACHA</b>	<b>P8SAGHMHA</b>
77	64	72	<b>P8SAGACHB</b>	<b>P8SAGHMHB</b>
141	128	136	<b>P8SAGACHD</b>	<b>P8SAGHMHD</b>
205	192	200	<b>P8SAGACHF</b>	<b>P8SAGMHMF</b>
269	256	264	<b>P8SAGACHH</b>	<b>P8SAGMHMH</b>

\*L2 equal to the measuring range.

**Note:**

PUR cable with M12 (IO-Link) or M8 (Analog) male connector knurled nut, 4-pin, 0,3 meter length.  
 Please consult for measuring range 96, 160 & 224 mm.

**Connection Type and Diagram**

**IO Link version**

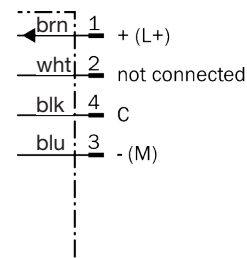

PUR 0.3 meter length  
 with M12 male connector  
 knurled nut, 4-pin

**Analog version**

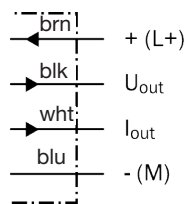

PUR 0.3 meter length  
 with M8 male connector  
 knurled nut, 4-pin

**Ordering Information, Drop-in T-slot**

Output	Measuring Length	Configuration Option	Part Number	Weight [g]	For Product Series
Analog	32 mm	Teach Button	<b>P8SAGACHA</b>	16	With T-slot groove *
	64 mm		<b>P8SAGACHB</b>	26	
	128 mm		<b>P8SAGACHD</b>	46	
	192 mm		<b>P8SAGACHF</b>	66	
	256 mm		<b>P8SAGACHH</b>	86	
IO-Link	32 mm	Teach Button or IO-Link parameter	<b>P8SAGHMHA</b>	20	With T-slot groove *
	64 mm		<b>P8SAGHMHB</b>	30	
	128 mm		<b>P8SAGHMHD</b>	50	
	192 mm		<b>P8SAGMHMF</b>	70	
	256 mm		<b>P8SAGMHMH</b>	90	

\* Required magnetic field sensitivity: 3mT / -2 mT (Analog) / 3mT (IO-Link)

**Note:**

PUR cable with M12 (IO-Link) or M8 (Analog) male connector knurled nut, 4-pin, 0,3 meter length.  
 Please consult for measuring range 96, 160 & 224 mm.



For inventory, lead times, and kit lookup, visit [www.pdnplu.com](http://www.pdnplu.com)

**Mountings and Brackets**

For Products Series	Part Number	Weight [g]
Tie rods, 4MA, P1F, P1D, PTR, 2MNR	<b>P8S-TMAOX</b>	65
Tie rods, P1F-T Ø 32-100	<b>P8S-TMA07</b>	10
Tie rods, P1F-T Ø 125-320	<b>P8S-TMA08</b>	32
T-Slot OSP Ø 10	<b>8872FIL</b>	3
T-Slot 2002 Series Ø 16	<b>8865FIL</b>	4
T-Slot 2002/P120 Series Ø 25-80	<b>8866FIL</b>	5
Round cylinder Ø10-25	<b>P8S-TMC01</b>	27
Round cylinder Ø 32-63	<b>P8S-TMC02</b>	29
Round cylinder Ø 80-125	<b>P8S-TMC03</b>	32
S-Dovetail OSP, pack of 10	<b>P8S-TMA09</b>	10

Ambient temperature -30 to +80 °C

All mountings can be moved on the cylinder body before screwing in place and then putting sensors in the slots.

**Dimensions, mm (inch)**

**P8S-TMC01, 02 & 03**

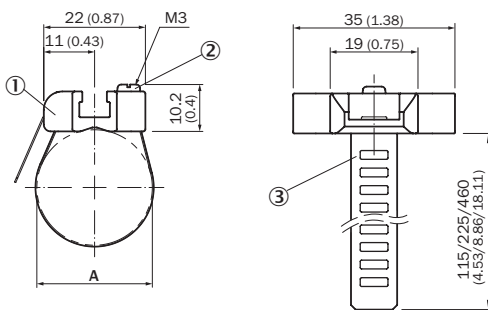

- ① Sensor adapter
- ② Fixing screw
- ③ Strap

Part number	D [mm]	
<b>P8S-TMC01</b>	8 to 25	Clamping ring in nickel silver, screw in stainless steel, sensor mounting zinc diecast
<b>P8S-TMC02</b>	32 to 63	
<b>P8S-TMC03</b>	80 to 130	

**P8S-TMAOX**

(Zinc diecast, zinc plated screws.)

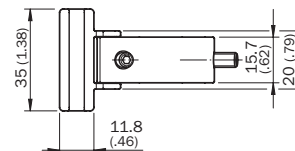
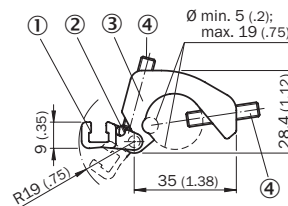

- ① Sensor adapter with T-Slot
- ② Fixing for cable < Ø 3.2 mm (0.126 inch)
- ③ Cylinder adapter
- ④ Mounting screws M5

**Tie Rod Bracket Assembly**

Tie Rod Bracket Assembly is necessary for Global and Mini-Global Sensor installation on all tie rod construction cylinders. This includes all Intermediate Trunnion mounts (Style DD or MT4); and all 6"-8" bore Sensors and bracket assemblies must be ordered separately.

Part number P8S-TMAOX fits 1-1/2" to 8" bores and 32-200mm bores for Global Sensors

**P8S-TMAOX**

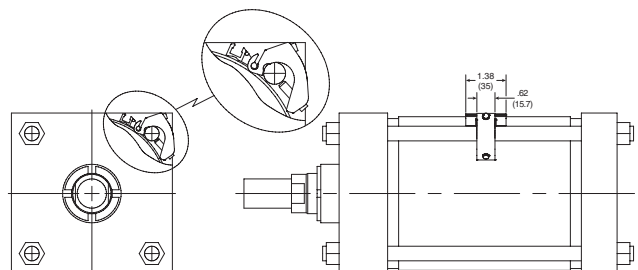

**Male Connectors for Connecting Cables**

Cable connectors for producing your own connecting cables. The connectors can be quickly attached to the cable without special tools. Only the outer sheath of the cable is removed. The connectors are available for M8 screw connector and meet protection class IP65.

**Technical Data**

<b>Operating voltage:</b>	max. 32 V AC/DC
<b>Operating current per contact:</b>	max. 4 A
<b>Connection cross section:</b>	0.25... 0.5 mm <sup>2</sup> (conductor diameter min 0.1 mm)
<b>Protection class:</b>	IP65 and IP67 when plugged and screwed down (EN 60529)
<b>Temperature range:</b>	- 25... + 85°C

Connector	Weight [kg]	Part number
M8 screw connector		<b>P8CS0803J</b>
M12 screw connector	0.022	<b>P8CS1204J</b>



**Cables to extend cable sensor lengths with M8\***

Description	Part Number	Weight [g]	For Product Series
Cable flex PVC 3 meter with 8mm snap-in connector / flying leads	<b>9126344341</b>	70	P8S Sensors with M8
Cable flex PVC 10 meter with 8mm snap-in connector / flying leads	<b>9126344342</b>	210	P8S Sensors with M8
Cable PUR 3 meter with 8mm snap-in female connector / flying leads	<b>9126344345</b>	70	P8S Sensors with M8
Cable flex PUR 10 meter with 8mm snap-in connector / flying leads	<b>9126344346</b>	210	P8S Sensors with M8
Cable PVC 5 meter with M8 screw female connector / flying leads	<b>KC3104</b>	120	P8S Sensors with knurled M8

\*Note: not applicable for P8S CPS Sensors as no cable available

Electronic and  
Reed Sensors

Continuous  
Position Sensor

Accessories

Sensor for  
Tie Rod Cylinder

Electronic  
Sensors



**Pneumatic Sensor for Tie-Rods Cylinders**

An ideal solution where a direct pneumatic signal is wanted from a cylinder sensor to a pneumatic control system, for example. This could be a machine or device in which only compressed air is available, and an electricity supply to normal cylinder sensors would involve serious problems or considerable expense.

**Function:**

Non-contacting sensing of a pneumatic cylinder, triggering an output signal (conn. 2) from the integrated 3/2 NC valve, which is activated by a magnetic field or iron core and has a return spring.

If more than one sensor is used with a cylinder there must be a distance of at least 20 mm between sensors to prevent them influencing each other.

To avoid interference, there must be a minimum spacing of 15 mm to steel details.

The outlet (conn. 3) must not be blocked or restricted as this can impair the function of the sensor.

The sensor is fastened to the cylinder using the special sensor fixing.

**Technical data:**

- Working pressure: min 2 to max 6 bar
- Temperature: -15 to +60 °C
- Air quality: 3.4.3 to ISO 8573-1 (must be oil free)
- Function: 3/2 NC valve
- Flow: 40 NI per minute
- Connection: for plastic pipe with 2,5-3 mm internal diameter
- Activation distance: for magnet: min 9 mm
- Activation distance: for Fe: approx. 2 mm
- Repetition accuracy: +/- 0.2 mm
- Cylinder velocity: max 1 m/s (depends on magnetic field, interference from steel in environment, signal length requirement from control system....)
- Distance between sensors: min 20 mm
- Distance from sensor to steel details: min 15 mm
- Fixing: with sensor fixing or with an M4 thread in case
- Sensing: non-contacting (also through a wall of non-magnetic material)

**Dimensions (mm)**

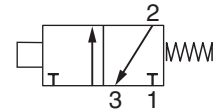
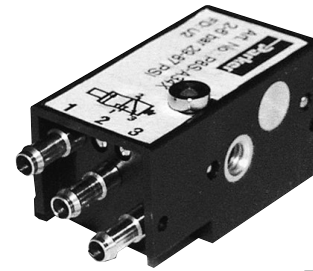
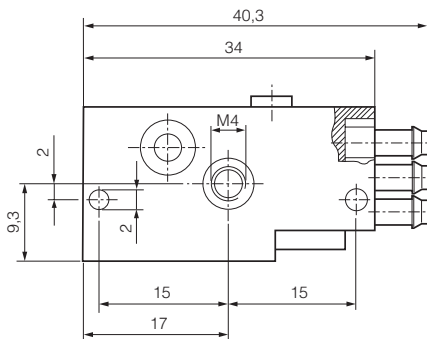
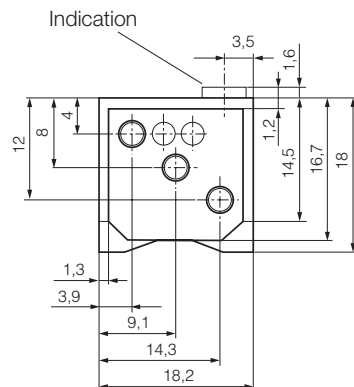

Description	Weight (kg)	Part Number
Pneumatic sensor	0.02	<b>P8S-A34X</b>
Cylinder fixing bore Ø32 to Ø125 mm	0.01	<b>P8S-AMA1</b>

**Cylinder fixing - Tie-Rod Cylinders Ø 32 to 100 mm**

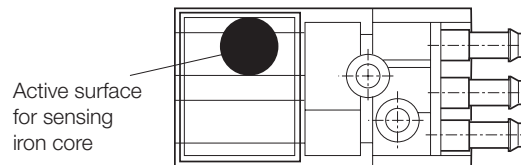
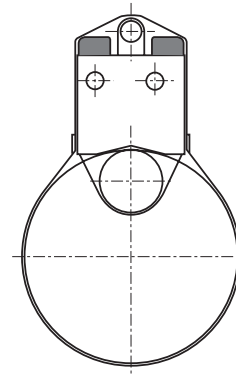

Electronic and Reed Sensors  
 Continuous Position Sensor  
 Accessories  
 Sensor for Tie Rod Cylinder  
 Electronic Sensors



For inventory, lead times, and kit lookup, visit [www.pdnplu.com](http://www.pdnplu.com)





## Industrial Shock Absorbers

Features	M2
General Information	M3-M7
Sizing Examples	M8-M11
Installation Examples	M12-M13
Model Rating Charts	M14-M15

### Miniature Shock Absorbers

MC 9 to MC 75 Series, Self-Compensating	M16-M17
MC 150 to MC 600 Series, Self-Compensating	M18-M19
SC 190 to SC 925 Series, Soft Contact & Self-Compensating	M20-M21
SC 300 to SC 650 Heavy Weight Series, Soft Contact & Self-Compensating	M22-M23
MA 35 to MA 900 Series, Adjustable	M24-M25

### Magnum Series Shock Absorbers

MC 33 to MC 64 Series, Self-Compensating	M26-M27
MA & ML 33 to 64, Adjustable	M28-M29
MC / MA / ML Dimensional Data	M30-M32

### Large Bore Series

1-1/2" Bore Series, Adjustable	M33-M34
2" & 3" CA Series, Heavy Industrial, Self-Compensating	M35-M38
4" CA Series, Heavy Industrial, Self-Compensating	M39-M40
2" & 3" A Series, Heavy Industrial, Adjustable	M41-M43

### Accessories

Miniature Series	M44-M47
Magnum Series	M48-M50



## Shock Absorbers

The use of one piece / closed end bodies and inner pressure chambers provides extremely strong construction, which can withstand much higher internal pressures and overload forces without mechanical damage.

The closed end / one piece bodies and inner pressure chambers, reduces the chance of sudden failure, or machine damage in the event of an overload.

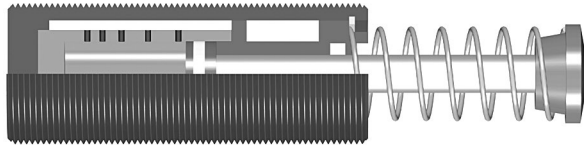

### Specifications

	Oil Type	Materials	Mechanical stop	Lock Nut
MC 9 - MC 75	Silicone	Steel body: Black oxide finish. Piston rod: Hardened stainless steel.	Integral mechanical stop built into front of units.	Included
MC 150 - MC 600	Silicone	Steel body: Black oxide finish. Piston rod: Hardened stainless steel. Rolling seal: EPDM*	Must be provided 0.02 to 0.04 inch (0.5 to 1 mm) before end of stroke.	Included
SC 190 - SC 925	#5	Steel body: Black oxide finish. Piston rod: Hardened stainless steel.	Integral mechanical stop built into front of units.	Included
SC 300 - SC 650	#5	Steel body: Black oxide finish. Piston rod: Hardened stainless steel.	Integral mechanical stop built into front of units.	Included
MA 35 - MA 900	MA 35: #5 MA 150: Silicone MA 225, 600, 900: ATF	Steel body: Black oxide finish. Piston rod: Hardened stainless steel.	Adjustment screw for optimum deceleration.	Included
MC 33 - MC 64 Self-Compensating	ATF	Steel body: Black oxide finish. Piston rod: Hardened, high tensile steel, chrome plated.		Included
MC 33 - MC 64 Adjustable	ATF	Rod end button: Hardened steel with black oxide finish. Return spring: Zinc plated	Turn front stop collar or rear adjuster against the scale marked 0 to 9 for optimum deceleration.	Included
1-1/2" Bore Series	American 46	Steel body: Black oxide finish. Piston rod: Hardened, high tensile steel, chrome plated. Return spring: Zinc plated	Must be provided .09 inch (2.3 mm) before end of stroke.	
CA 2 - CA 4 Self-Compensating	ATF	Steel body: Black oxide finish. Piston rod: Hardened, high tensile steel, chrome plated.	Must be provided .09 inch (2.3 mm) before end of stroke.	
A 2 - A 3 Adjustable	ATF	Return spring: Zinc plated	Must be provided .09 inch (2.3 mm) before end of stroke.	

\* Seal not compatible with petroleum based fluids) If unit to be used in contact with such fluids specify neoprene rolling seal. Consider the SC2 Series as an alternative.

**Miniature shock absorbers  
 MC 9 to MC 75  
 Self-compensating**

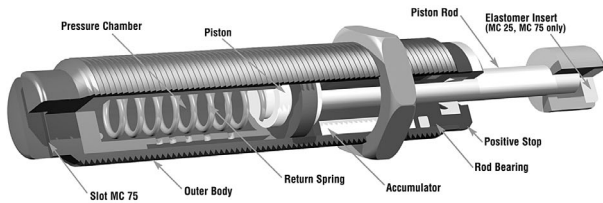

**Miniature shock absorbers  
 MC 150, MC 225 and MC 600  
 Self-Compensating**

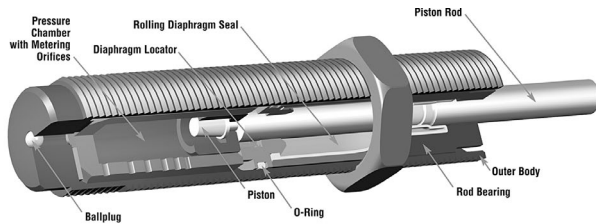

**Heavyweight shock absorbers  
 SC 300 and SC 650  
 Soft Contact and Self-Compensating**

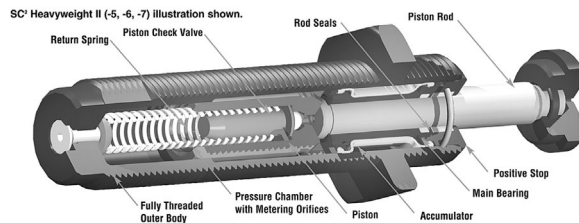

**Miniature shock absorbers  
 SC 190 to SC 925  
 Soft Contact and Self-Compensating**

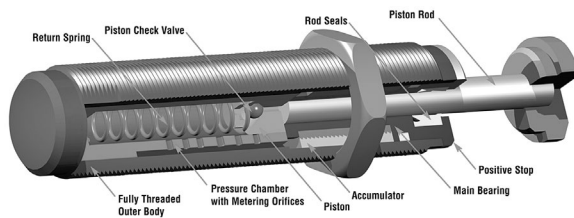

**MA series 225-900 shock absorbers  
 (Miniature adjustable)  
 Adjustable**

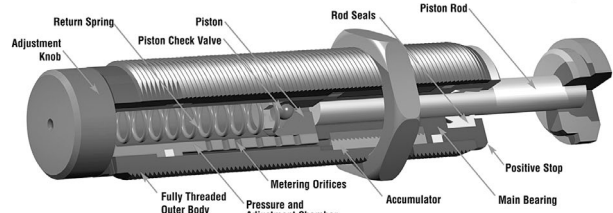

**Magnum series MA and ML 33 to 64  
 Adjustable**

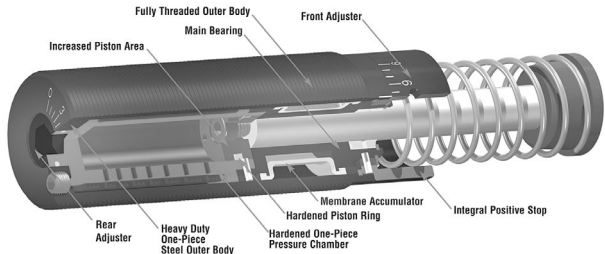

**Heavy industrial shock absorbers  
 CA to CA 4  
 Self-Compensating**

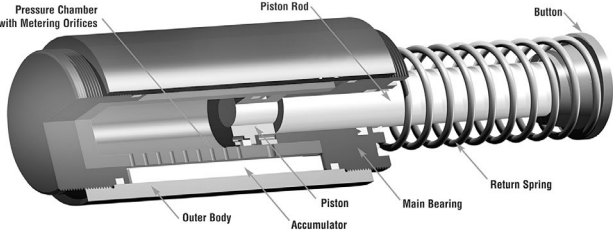

**Heavy industrial shock absorbers  
 A2 to A3  
 Adjustable**

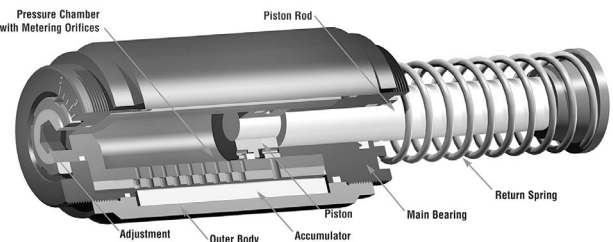

Industrial Shock Absorbers

M



**Linear Decelerators**

1. **Cylinder Cushions and Dashpots (High stopping force at start of the stroke).** With only one metering orifice, the moving load is abruptly slowed down at the start of the stroke. The braking force rises to a very high peak at the start of the stroke (giving high shock loads) and then falls away rapidly.
2. **Springs and Rubber Bumpers (High stopping forces at end of stroke).** The moving load is slowed down by a constantly rising reaction force up to the point of full compression. These devices store energy rather than dissipate it, which causes the load to bounce back.
3. **Industrial Shock Absorbers (Uniform stopping force through the entire stroke).** The moving load is smoothly and gently brought to rest by a constant resisting force throughout the entire shock absorber stroke. The load is decelerated with the lowest possible force, in the shortest possible time, eliminating damaging force peaks and shock damage to machines and equipment. This is a linear deceleration force stroke curve and is the curve provided by industrial shock absorbers.

**Comparison**

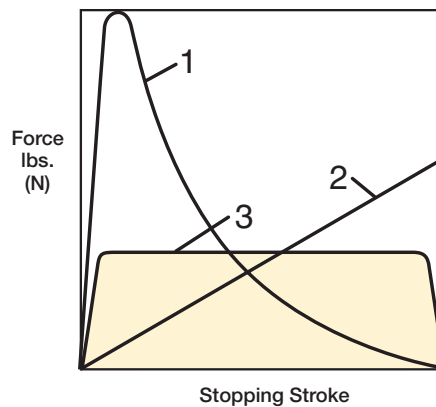

**Energy Capacity**

- Premise:** Same maximum reaction force.
- Result:** The shock absorber can absorb considerably more energy (represented by the area under the curve.)
- Benefit:** By installing a shock absorber production rates can be more than doubled without increasing deceleration forces or reaction forces on the machine.

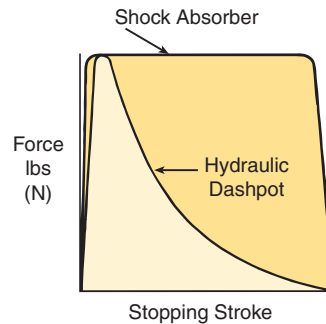

**Reaction Force (stopping force)**

- Premise:** Same energy absorption (area under the curve).
- Result:** The reaction force transmitted by the shock absorber is very much lower.
- Benefit:** By installing the shock absorber the machine wear and maintenance can be drastically reduced.

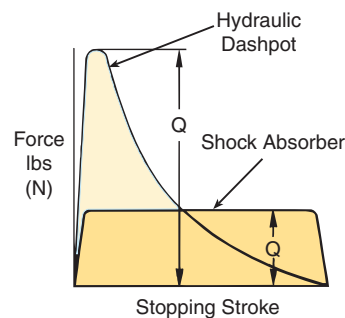

**Stopping Time**

- Premise:** Same energy absorption.
- Result:** The shock absorber stops the moving load in a much shorter time.
- Benefit:** By installing a shock absorber cycle times are reduced giving much higher production rates.

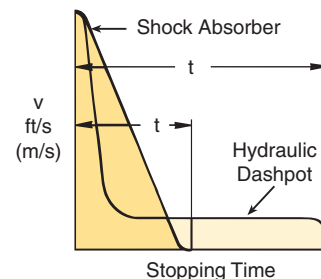

The use of one piece / closed end bodies and inner pressure chambers provides an extremely strong construction, which can withstand much higher internal pressures and overload forces without mechanical damage. Consider what happens if the shock absorber is accidentally overloaded or in the unlikely event of partial oil loss due to excessive seal wear or damage. Compare the internal design used by Parker with that of some of its competitors:

**Parker Shock Absorber**

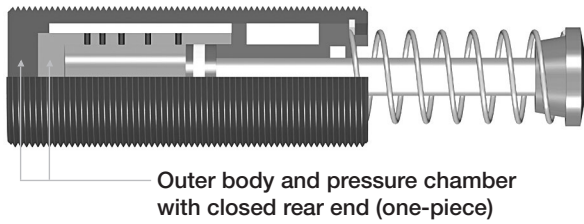

Outer body and pressure chamber with closed rear end (one-piece)

**Other Shock Absorber**

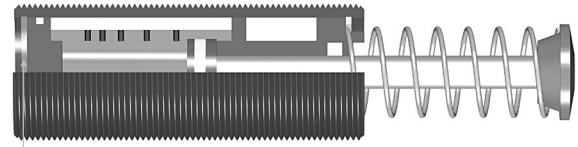

Snap Ring (Outer body and inner pressure chamber made from tube stock.)

Parker builds its shock absorbers with closed end/one piece bodies and inner pressure chambers, which greatly reduces the chance of sudden failure, or machine damage in the event of an overload.

**What happens with an overload or gradual oil loss?**

Harder bottoming out force becomes apparent. The shock absorber continues to work and can be replaced then or at the end of the shift.

**Corrective Action:**

Remove and replace the shock absorber. Refill with fresh oil or repair.

Some other manufacturers use bodies and inner pressure chambers made from tube stock. The internal parts are held in by a snap ring etc. which then takes all the load and can fail suddenly and catastrophically.

**What happens with an overload or gradual oil loss?**

The snap ring breaks or is extruded due to excessive force. Machine damage!! Equipment Stops!! Production Halted!! Emergency Repair!!

**Corrective Action:**

Remove and replace the shock absorber with new one (repair not possible).

$v = 6.56 \text{ ft/sec (2 m/s)}$      $v = 4.92 \text{ ft/sec (1.5 m/s)}$      $v = 3.28 \text{ ft/sec (1 m/s)}$      $v = 1.64 \text{ ft/sec (0.5 m/s)}$      $v = 0 \text{ ft/sec (0 m/s)}$

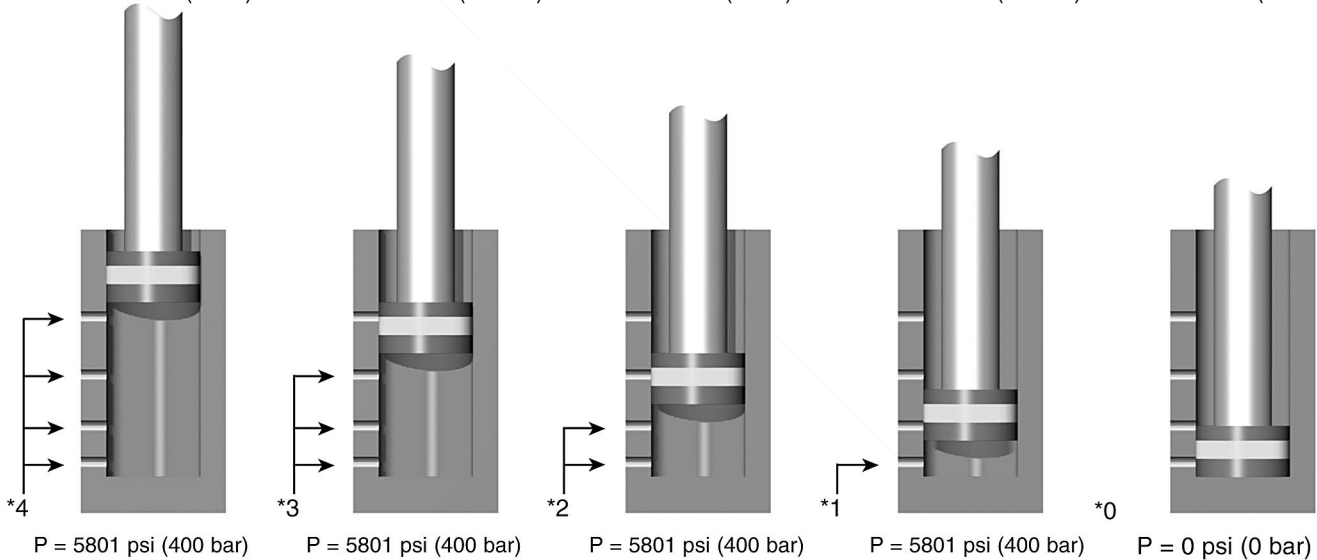

\* As a moving load impacts the shock absorber, the piston travels through stroke and forces hydraulic fluid through the multi-orifice inner tube. The total orifice area decreases at a rate consistent with the decay of impact velocity, resulting in true linear deceleration.

- F = Force lbs (N)
- P = Internal pressure psi (bar)
- s = Stroke in (m)
- t = Deceleration time (s)
- v = Velocity ft/s (m/s)

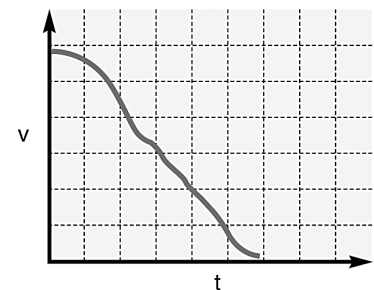
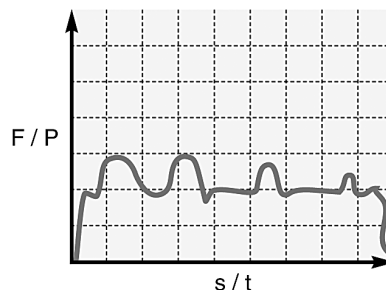

## Deceleration Principles

Effective weight is an important factor in selecting shock absorbers. A shock absorber “sees” the impact of an object in terms of weight and velocity only; it does not “see” any propelling force. The effective weight can be thought of as the weight that the shock absorber “sees” on impact. Effective weight includes the effect of the propelling force on the performance of the shock absorber.

Failing to consider the effective weight may result in improper selection and poor performance of the shock absorber. Under extreme conditions, an effective weight that is too low may result in high forces at the start of stroke (high on-set force). However, an effective weight that is too high for the shock absorber may cause high forces at the end of stroke (high set-down force).

### Consider the following examples:

1. A 5 lb (2.27 kg) weight travelling at 25 ft/sec (7.62 m/s) has 625 lbs (71 Nm) of kinetic energy (**Figure A**). On this basis alone, an MA 3325 would be selected. However, because there is no propelling force, the calculated effective weight is five pounds – which is below the effective weight range of the standard MA 3325. This is a high on-set force at the start of the stroke (**Figure B**). The solution is to use a specially-orificed shock absorber to handle the load.
2. A weight of 50 lbs (22.68 kg) has an impact velocity of 0.5 ft/sec (0.15 m/s) with a propelling force of 800 lbs (111N) (**Figure C**). The total impact energy is 802.5 inch-pounds. Again, an MA 3325 would be selected based just on the energy. The effective weight is calculated to be 16,050 pounds (7,280 kg). This is well above the range of the standard MA 3325. If this shock absorber is used, high-set-down forces will result (**Figure D**). In this case, the solution is to use a ML 3325, which is designed to work in low-velocity, high-effective weight applications.

## Industrial Shock Absorbers Linear Decelerators, Effective Weight

**Figure A**

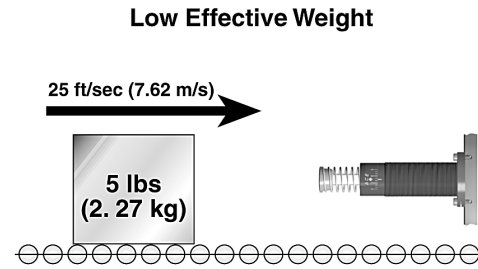

**Figure B**

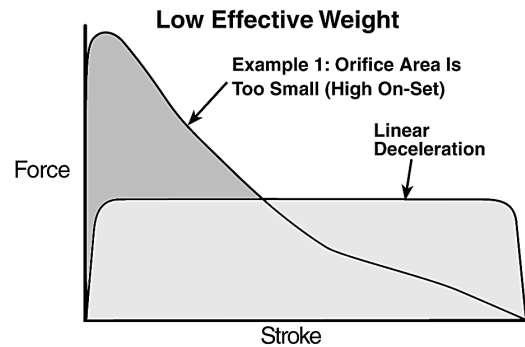

**Figure C**

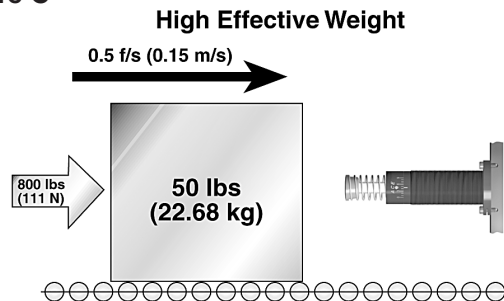

**Figure D**

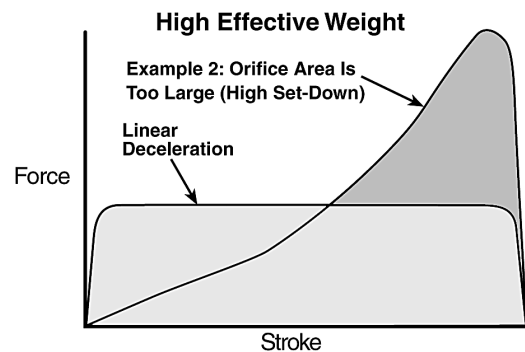

### Computer-Aided Simulation

By combining application data with a shock absorbers design parameters, Parker engineers can create a picture of how the shock will perform when impacted by the application load. Peak reaction force, peak deceleration (G's), time through stroke, and velocity decay are identified with extreme accuracy. The user benefits by having the guesswork taken out of sizing decisions and by knowing before installation how his shock problem will be solved.



**Self-Compensating Shock Absorbers**

In cases where non-adjustability is beneficial but the features of an adjustable shock absorber are required, self-compensating shocks meet both needs. With a range of effective weight, a self-compensating shock absorber will provide acceptable deceleration under changing energy conditions.

The orifice profile, designed by a computer that constantly arranges the size and location of each orifice while inputting changing effective weights, neutralizes the effect of changing fluid coefficients, weight, velocity, temperature and fluid compressibility.

**Figure A**

A linear decelerator by definition decelerates a moving weight at a linear or constant rate of deceleration. The adjustable shock absorber is able to provide linear deceleration when operated within its energy capacity and effective weight range by dialing in the required orifice area. The resulting force-stroke curve (Figure A) shows optimum (lowest) stopping force.

**Figure A**

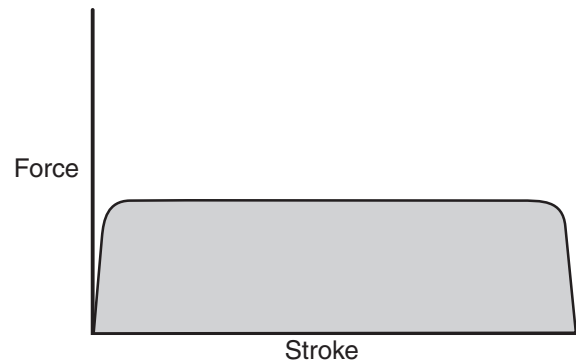

**Figure B**

Figure B shows the force-stroke of a self-compensating shock absorber stopping a weight at the low end of its effective weight range. Note how the reaction forces are no longer constant but are still acceptable. The curve is skewed slightly higher at the beginning of the stroke and dips lower at the end.

**Figure B**

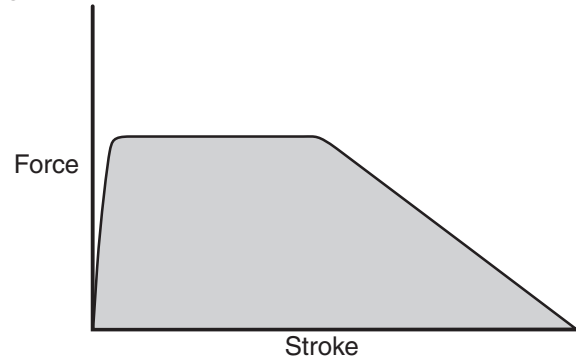

**Figure C**

Figure C is a force-stroke curve of the same self-compensating shock absorber in Figure B but at the high end of its effective weight range. The energy curve is now skewed upward at the end of stroke and still yields acceptable deceleration.

**Figure C**

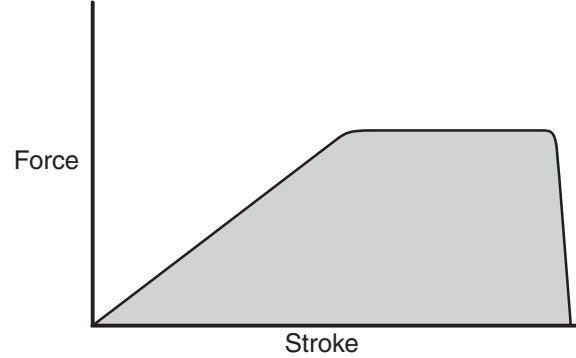
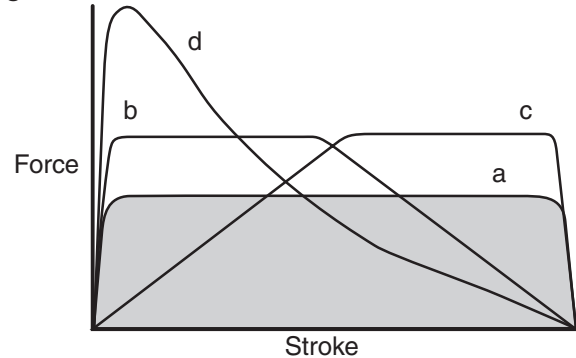

**Figure D**

Figure D is a family of force-stroke curves:

- a. Adjustable shock absorber properly tuned, or hydro shock perfectly matched.
- b. Self-compensating shock absorber at the low end of its effective weight range.
- c. Self-compensating shock absorber at the high end of its effective weight range.
- d. Adjustable closed down, or hydro shock not matched (dashpot effect).

**Figure D**



Industrial Shock Absorbers

M

Horizontal Sizing Examples

W = Moving Weight (lbs)	Hp = Motor Power (horsepower)	E <sub>1</sub> = Kinetic Energy (in lbs)
V = Impact Velocity (ft/sec)	Mu = Coefficient of Friction	E <sub>2</sub> = Propelling Force Energy (in lbs)
Fp = Known Propelling Force (lbs)	C = Cycles per Hour (/hour)	E <sub>3</sub> = Energy per Cycle (in lbs)
B = Propelling Cylinder Bore (inches)	s = Stroke Length of Shock Absorber (inches)	E <sub>4</sub> = Energy per hour (in lbs/hour)
R = Propelling Cylinder Rod (inches)	F = Propelling Force at Shock Absorber (lbs)	We = Effective Weight (lbs)
P = Air Pressure (psi)		

H1 Weight with No Propelling Force

Examples: Crash Testers, Emergency Stops

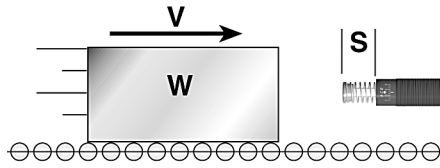

FORMULA

$$E_1 = (0.186) \cdot (W) \cdot (V^2)$$

$$E_2 = (F) \cdot (s)$$

$$E_3 = E_1 + E_2$$

$$E_4 = (E_3) \cdot (C)$$

$$We = E_3 / (0.186) \cdot (V^2)$$

EXAMPLE

W = 500 lbs	F <sub>1</sub> = (0.186)•(500)•(3 <sup>2</sup> ) = 837 in lbs
V = 3 ft/sec	E <sub>2</sub> = (0)•(1) = 0 in lbs
Fp = 0	E <sub>3</sub> = 900 + 0 = 837 in lbs
C = 500/hour	E <sub>4</sub> = (837)•(500) = 418,500 in lbs/h
	We = 837 / (0.186)•(3 <sup>2</sup> ) = 500 lbs

H1 - Select from Model Rating Chart: MC 3325-3 or MA 3325

H2 Weight with Propelling Force

Transfer Devices, Safety Doors, Cutting Shears

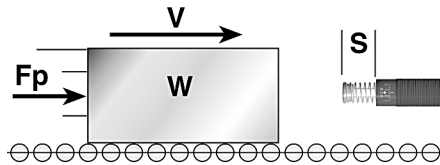

$$F = Fp$$

$$E_1 = (0.186) \cdot (W) \cdot (V^2)$$

$$E_2 = (F) \cdot (s)$$

$$E_3 = E_1 + E_2$$

$$E_4 = (E_3) \cdot (C)$$

$$We = E_3 / (0.186) \cdot (V^2)$$

W = 14 lbs	F = 30	= 30 lbs
V = 2.2 ft/sec	E <sub>1</sub> = (0.186)•(14)•(2.2 <sup>2</sup> ) = 12.6 in lbs	
Fp = 30 lbs	E <sub>2</sub> = (30)•(0.4) = 12 in lbs	
C = 100/hour	E <sub>3</sub> = 12.6 + 12 = 24.6 in lbs	
s = 0.4 inches	E <sub>4</sub> = (24.6)•(100) = 2,460 in lbs/h	
	We = 24.6 / (0.186)•(2.2 <sup>2</sup> ) = 27.3 lbs	

H2 - Select from Model Rating Chart: MC 75-3

H3 Weight with Propelling Cylinder

Pick-and Place Units, Linear Slides, Robotics

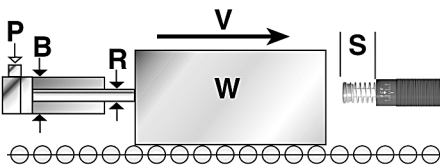

$$F = 0.785 \cdot (B^2 - R^2) \cdot (P)$$

$$E_1 = (0.186) \cdot (W) \cdot (V^2)$$

$$E_2 = (F) \cdot (s)$$

$$E_3 = E_1 + E_2$$

$$E_4 = (E_3) \cdot (C)$$

$$We = E_3 / (0.186) \cdot (V^2)$$

W = 120 lbs	F = 0.785•(1.5 <sup>2</sup> -0 <sup>2</sup> )•60 = 106 lbs
V = 2 ft/sec	E <sub>1</sub> = (0.186)•(120)•(2 <sup>2</sup> ) = 89.3 in lbs
B = 1.5 inches	E <sub>2</sub> = (106)•(0.75) = 79.5 in lbs
R = 0 inches	E <sub>3</sub> = 89.3 + 79.5 = 168.8 in lbs
P = 60 psi	E <sub>4</sub> = (168.8)•(60) = 10,128 in lbs/h
C = 60/hour	We = 168.8 / (0.186)•(2 <sup>2</sup> ) = 226.9 lbs
s = 0.75 inches	

Note: R = 0 when using a rodless cylinder or a cylinder working in extension.

H3 - Select from Model Rating Chart: MA 225 or SC 300-4

H4 Weight with Motor Drive

Lift Trucks, Stacker Units, Overhead Cranes

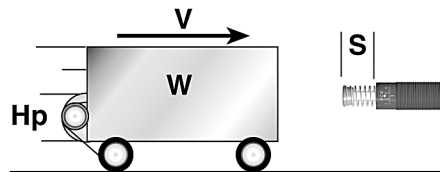

$$F = (550) \cdot (ST) \cdot (Hp) / V$$

$$E_1 = (0.186) \cdot (W) \cdot (V^2)$$

$$E_2 = (F) \cdot (s)$$

$$E_3 = E_1 + E_2$$

$$E_4 = (E_3) \cdot (C)$$

$$We = E_3 / (0.186) \cdot (V^2)$$

W = 2,100 lbs	F = (550)•(2.5)•(2) / 1 = 2,750 lbs
V = 1 ft/sec	E <sub>1</sub> = (0.186)•(2,100)•(1 <sup>2</sup> ) = 390.6 in lbs
Hp = 2 hp	E <sub>2</sub> = (2,750)•(2) = 5,500 in lbs
ST = 2.5	E <sub>3</sub> = 390.6 + 5,500 = 5,890.6 in lbs
C = 20/hour	E <sub>4</sub> = (5,890.6)•(20) = 117,812 in lbs/h
s = 2 inches	We = 5,890.6 / (0.186)•(1 <sup>2</sup> ) = 31,670 lbs

H4 - Select from Model Rating Chart: ML 6450 or MC 6450-4

H5 Weight on Power Rollers/Conveyor

Pallet Line, Friction Conveyor Belt, Steel Tube Transfer

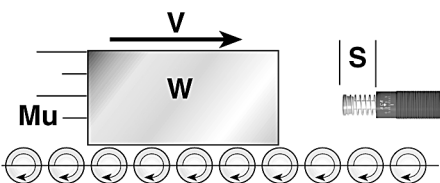

$$F = (W) \cdot (Mu)$$

$$E_1 = (0.186) \cdot (W) \cdot (V^2)$$

$$E_2 = (F) \cdot (s)$$

$$E_3 = E_1 + E_2$$

$$E_4 = (E_3) \cdot (C)$$

$$We = E_3 / (0.186) \cdot (V^2)$$

W = 250 lbs	F = (250)•(0.2) = 50 lbs
V = 2.5 ft/sec	E <sub>1</sub> = (0.186)•(250)•(2.5 <sup>2</sup> ) = 290.6 in lbs
Mu = 0.2	E <sub>2</sub> = (50)•(1) = 50 in lbs
C = 180/hour	E <sub>3</sub> = 290.6 + 50 = 340.6 in lbs
s = 1 inch	E <sub>4</sub> = (340.6)•(180) = 61,308 in lbs/h
	We = 340.6 / (0.186)•(2.5 <sup>2</sup> ) = 293 lbs

H5 - Select from Model Rating Chart: MA 600 or SC 650-3

W = Moving Weight  
 V = Impact Velocity  
 Fp = Known Propelling Force  
 M = Total Distance Moved by Weight  
 D = Distance Moved by Weight to Shock

(lbs) A = Angle of Inclined Plane  
 (ft/sec) W<sub>cw</sub> = Counter Weight  
 (lbs) C = Cycles per Hour  
 (inches) s = Stroke Length of Shock Absorber  
 (inches) F = Propelling Force at Shock Absorber

(°) E<sub>1</sub> = Kinetic Energy (in lbs)  
 (lbs) E<sub>2</sub> = Propelling Force Energy (in lbs)  
 (/hour) E<sub>3</sub> = Energy per Cycle (in lbs)  
 (inches) E<sub>4</sub> = Energy per hour (in lbs/hour)  
 (lbs) We = Effective Weight (lbs)

**V1 Weight, Vertical Free Fall**

**Examples: Elevator Emergency Stops, Flying Shears, Test Equipment**

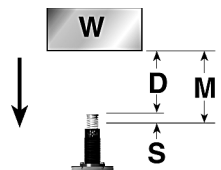

**FORMULA**  
 $D = (M) - (s)$   
 $V = \sqrt{(5.4) \cdot (D) \cdot \sin(A)}$   
 $F = (W) \cdot \sin(A)$   
 $E_1 = (0.186) \cdot (W) \cdot (V^2)$   
 $E_2 = (F) \cdot (s)$   
 $E_3 = E_1 + E_2$   
 $E_4 = (E_3) \cdot (C)$   
 $We = E_3 / (0.186) \cdot (V^2)$

**EXAMPLE**  
 W = 200 lbs  
 M = 18 inches  
 C = 60/hour  
 s = 3 inches

D = (18) - (3) = 15 inches  
 V =  $\sqrt{(5.4) \cdot (15)}$  = 9 ft/sec  
 F = 200 = 200 lbs  
 E<sub>1</sub> = (0.186) • (200) • (9<sup>2</sup>) = 3,013.2 in lbs  
 E<sub>2</sub> = (200) • (3) = 600 in lbs  
 E<sub>3</sub> = 3,013.2 + 600 = 3,613.2 in lbs  
 E<sub>4</sub> = (3,013.2) • (60) = 216,792 in lbs/h  
 We = 3,013.2 / (0.186) • (9<sup>2</sup>) = 239.8 lbs

V1 - Select from Model Rating Chart: MA 4575

**V2 Weight Sliding Down Incline**

**Inclined Non-Powered Conveyor, Package Chute, Parts Transfer Ramp**

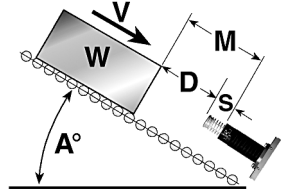

**FORMULA**  
 $D = (M) - (s)$   
 $V = \sqrt{(5.4) \cdot (D) \cdot \sin(A)}$   
 $F = (W) \cdot \sin(A)$   
 $E_1 = (0.186) \cdot (W) \cdot (V^2)$   
 $E_2 = (F) \cdot (s)$   
 $E_3 = E_1 + E_2$   
 $E_4 = (E_3) \cdot (C)$   
 $We = E_3 / (0.186) \cdot (V^2)$

W = 1,000 lbs  
 M = 15 inches  
 A = 30°  
 C = 190/hour  
 s = 2 inches

D = (15) - (2) = 13 inches  
 V =  $\sqrt{(5.4) \cdot (13) \cdot \sin(30)}$  = 5.9 ft/sec  
 F = 500 = 500 lbs  
 E<sub>1</sub> = (0.186) • (1,000) • (5.9<sup>2</sup>) = 6,474.7 in lbs  
 E<sub>2</sub> = (500) • (2) = 1,000 in lbs  
 E<sub>3</sub> = 6,474.7 + 1,000 = 7,474.7 in lbs  
 E<sub>4</sub> = (7,474.7) • (190) = 1,420,193 in lbs/h  
 We = 7,474.7 / (0.186) • (5.9<sup>2</sup>) = 1,154.5 lbs

V2 - Select from Model Rating Chart: MCA 6450-1 or -2

**V3 Down Incline with Propelling Force**

**Inclined Conveyor Belt, High Speed Safety Doors**

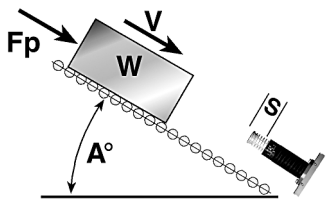

**FORMULA**  
 $F = (W) \cdot \sin(A) + (Fp)$   
 $E_1 = (0.186) \cdot (W) \cdot (V^2)$   
 $E_2 = (F) \cdot (s)$   
 $E_3 = E_1 + E_2$   
 $E_4 = (E_3) \cdot (C)$   
 $We = E_3 / (0.186) \cdot (V^2)$

W = 100 lbs  
 V = 2 ft/sec  
 Fp = 50 lbs  
 A = 15°  
 C = 30/hour  
 s = 0.5 inches

F = (100) • sin(15) + (50) = 75.9  
 E<sub>1</sub> = (0.186) • (100) • (2<sup>2</sup>) = 74.4 lbs  
 E<sub>2</sub> = (75.9) • (0.5) = 38 in lbs  
 E<sub>3</sub> = 74.4 + 38 = 112.4 in lbs  
 E<sub>4</sub> = (112.4) • (30) = 3,370.5 in lbs  
 We = 112.4 / (0.186) • (2<sup>2</sup>) = 151.1 in lbs

V3 - Select from Model Rating Chart: MC 150H

**V4 Up Incline with Propelling Force**

**Elevator, Inclined Power Conveyor**

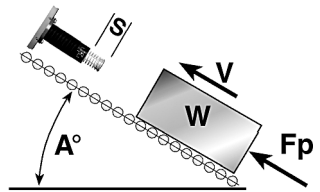

**FORMULA**  
 $F = (Fp) - (W) \cdot \sin(A)$   
 $E_1 = (0.186) \cdot (W) \cdot (V^2)$   
 $E_2 = (F) \cdot (s)$   
 $E_3 = E_1 + E_2$   
 $E_4 = (E_3) \cdot (C)$   
 $We = E_3 / (0.186) \cdot (V^2)$

W = 450 lbs  
 V = 1 ft/sec  
 Fp = 600 lbs  
 A = 90°  
 C = 60/hour  
 s = 1 inch

F = (600) - (450) • sin(90) = 150 lbs  
 E<sub>1</sub> = (0.186) • (450) • (1<sup>2</sup>) = 83.7 in lbs  
 E<sub>2</sub> = (150) • (1) = 150 in lbs  
 E<sub>3</sub> = 90 + 150 = 234 in lbs  
 E<sub>4</sub> = (234) • (60) = 14,022 in lbs/h  
 We = 240 / (0.2) • (1<sup>2</sup>) = 1,258.1 lbs

V4 - Select from Model Rating Chart: MA 600 or SC 650-4

**V5 Down Incline with Counter Weight**

**Lifting Door with Counter Balance**

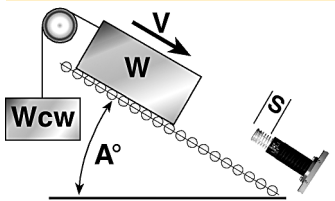

**FORMULA**  
 $F = (W) \cdot \sin(A) - W_{cw}$   
 $E_1 = (0.186) \cdot (W) \cdot (V^2)$   
 $E_2 = (F) \cdot (s)$   
 $E_3 = E_1 + E_2$   
 $E_4 = (E_3) \cdot (C)$   
 $We = E_3 / (0.186) \cdot (V^2)$

W = 1,500 lbs  
 V = 0.5 ft/sec  
 A = 45°  
 W<sub>cw</sub> = 500 lbs  
 C = 1/hour  
 s = 1 inch

F = (1,500) • sin(45) - 500 = 560.7 lbs  
 E<sub>1</sub> = (0.186) • (1,500) • (0.5<sup>2</sup>) = 69.8 in lbs  
 E<sub>2</sub> = (560.7) • (1) = 560.7 in lbs  
 E<sub>3</sub> = 69.8 + 560.7 = 630.5 in lbs  
 E<sub>4</sub> = (636) • (1) = 630.5 in lbs/h  
 We = 630.5 / (0.186) • (0.5<sup>2</sup>) = 13,559.1 lbs

V5 - Select from Model Rating Chart: ML 3325



For inventory, lead times, and kit lookup, visit [www.pdnplu.com](http://www.pdnplu.com)



Rotary Sizing Examples

W = Moving Weight (lbs)	T = Propelling Torque (lbs-in)	C = Cycles per Hour (/hour)
V = Impact Velocity (ft/sec)	Rs = Mounting Radius of the Shock (inches)	E <sub>1</sub> = Kinetic Energy (in lbs)
Wa = Apparent Weight at Shock Absorber (lbs)	Rt = Radius to Edge of Turntable (inches)	E <sub>2</sub> = Propelling Force Energy (in lbs)
ω = Angular Velocity (°/sec)	s = Stroke Length of Shock Absorber (inches)	E <sub>3</sub> = Energy per Cycle (in lbs)
I = Moment of Inertia (lb-ft-sec <sup>2</sup> )	H = Thickness of Object (inches)	E <sub>4</sub> = Energy per hour (in lbs/hour)
k = Radius of Gyration (inches)	L = Length of Object (inches)	We = Effective Weight (lbs)

**R1 Moment of Inertia, Horizontal Plane**      **Examples: Swing Bridges, Radar Antenna**

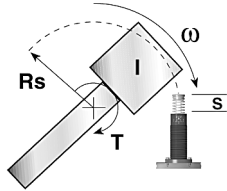

**FORMULA**

$$\begin{aligned} Wa &= (4637 \cdot I) / Rs^2 \\ V &= (Rs) \cdot (\omega) / 688 \\ F &= T / Rs \\ E_1 &= (0.186) \cdot (Wa) \cdot (V^2) \\ E_2 &= (F) \cdot (s) \\ E_3 &= E_1 + E_2 \\ E_4 &= (E_3) \cdot (C) \\ We &= E_3 / (0.186) \cdot (V^2) \end{aligned}$$

**EXAMPLE**

I = 3,930 lb-ft-sec <sup>2</sup>	Wa = (4,637 • 3,930) / (40 <sup>2</sup> )	= 11,390 lbs
ω = 172°/sec	V = (40) • (172) / 688	= 10 ft/sec
T = 480,000 lbs-in	F = 480,000 / 40	= 12,000 lbs
Rs = 40 inches	E <sub>1</sub> = (0.186) • (11,390) • (10 <sup>2</sup> )	= 211,854 in lbs
C = 30/hour	E <sub>2</sub> = (12,000) • (6)	= 72,000 in lbs
s = 6 inches	E <sub>3</sub> = 211,854 + 72,000	= 283,854 in lbs
	E <sub>4</sub> = (283,854) • (30)	= 8,515,620 in lbs/h
	We = 283,854 / (0.186) • (10 <sup>2</sup> )	= 15,260.9 lbs

R1 - Select from Model Rating Chart: CA 4 x 6-3

**R2 Radius of Gyration, Horizontal Plane**      **Examples: Packaging Equipment, Pick-and-Place Robots**

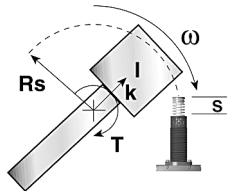

$$\begin{aligned} Wa &= (W) \cdot (k^2) / (Rs^2) \\ V &= (Rs) \cdot (\omega) / 688 \\ F &= T / Rs \\ E_1 &= (0.186) \cdot (Wa) \cdot (V^2) \\ E_2 &= (F) \cdot (s) \\ E_3 &= E_1 + E_2 \\ E_4 &= (E_3) \cdot (C) \\ We &= E_3 / (0.186) \cdot (V^2) \end{aligned}$$

W = 300 lbs	Wa = (300) • (2.5 <sup>2</sup> ) / (25 <sup>2</sup> )	= 3 lbs
k = 2.5 inches	V = (25) • (180) / 688	= 6.54 ft/sec
ω = 180°/sec	F = 9,000 / 25	= 360 lbs
T = 9,000 lbs-in	E <sub>1</sub> = (0.186) • (3) • (6.54 <sup>2</sup> )	= 23.87 in lbs
Rs = 25 inches	E <sub>2</sub> = (360) • (1)	= 360 in lbs
C = 1,200/hour	E <sub>3</sub> = 23.87 + 360	= 383.87 in lbs
s = 1 inch	E <sub>4</sub> = (383.87) • (1,200)	= 460,644 in lbs/h
	We = 383.87 / (0.186) • (6.54 <sup>2</sup> )	= 48.20 lbs

R2 - Select from Model Rating Chart: MC 3325-1 or MA 3325

**R3 Index Table**      **Examples: Index Table, Rotating Work Station**

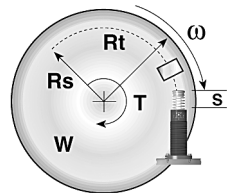

$$\begin{aligned} Wa &= (W \cdot Rt^2) / (2 \cdot Rs^2) \\ V &= (Rs) \cdot (\omega) / 688 \\ F &= T / Rs \\ E_1 &= (0.186) \cdot (Wa) \cdot (V^2) \\ E_2 &= (F) \cdot (s) \\ E_3 &= E_1 + E_2 \\ E_4 &= (E_3) \cdot (C) \\ We &= E_3 / (0.186) \cdot (V^2) \end{aligned}$$

W = 195 lbs	Wa = (195 • 20 <sup>2</sup> ) / (2 • 15 <sup>2</sup> )	= 173.3 lbs
Rt = 20 inches	V = (15) • (85) / 688	= 1.85 ft/sec
ω = 85°/sec	F = 1,700 / 15	= 113.3 lbs
T = 1,700 lbs-in	E <sub>1</sub> = (0.186) • (173.3) • (1.85 <sup>2</sup> )	= 110.3 in lbs
Rs = 15 inches	E <sub>2</sub> = (113.3) • (0.75)	= 85 in lbs
C = 60/hour	E <sub>3</sub> = 110.3 + 85	= 195.3 in lbs
s = .75 inches	E <sub>4</sub> = (195.3) • (60)	= 11,718 in lbs/h
	We = 195.3 / (0.186) • (1.85 <sup>2</sup> )	= 306.8 lbs

R3 - Select from Model Rating Chart: SC 300-4 or MC 225H

**R4 Turnover**      **Examples: Roll-Over Device, Paint Booths, Crate Handling**

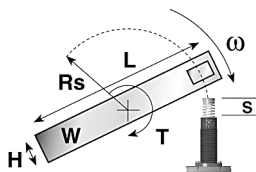

$$\begin{aligned} Wa &= (W) \cdot (H^2 + L^2) / 12 \cdot (Rs^2) \\ V &= (Rs) \cdot (\omega) / 688 \\ F &= T / Rs \\ E_1 &= (0.186) \cdot (Wa) \cdot (V^2) \\ E_2 &= (F) \cdot (s) \\ E_3 &= E_1 + E_2 \\ E_4 &= (E_3) \cdot (C) \\ We &= E_3 / (0.186) \cdot (V^2) \end{aligned}$$

W = 150 lbs	Wa = (150) • (12 <sup>2</sup> + 38 <sup>2</sup> ) / (12 • 12 <sup>2</sup> )	= 125.43 lbs
L = 38 inches	V = (12) • (70) / 688	= 1.22 ft/sec
H = 1 inch	F = 15,000 / 12	= 1,250 lbs
ω = 70°/sec	E <sub>1</sub> = (0.186) • (125.43) • (1.22 <sup>2</sup> )	= 34.72 in lbs
T = 15,000 lbs-in	E <sub>2</sub> = (1,250) • (1)	= 1,250 in lbs
Rs = 12 inches	E <sub>3</sub> = 34.72 + 1,250	= 1,284.72 in lbs
C = 500/hour	E <sub>4</sub> = (1,284.72) • (500)	= 642,360 in lbs/h
s = 1 inch	We = 1,284.72 / (0.186) • (1.22 <sup>2</sup> )	= 4,640.6 lbs

R4 - Select from Model Rating Chart: MC 4525-4 or MA 4525

**R5 Uniform Bar, Horizontal Plane**      **Examples: Swinging Beam, Robotic Arm**

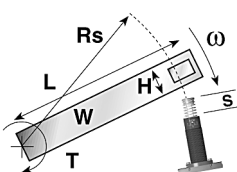

$$\begin{aligned} Wa &= (W) \cdot (H^2 + 4 \cdot L^2) / 12 \cdot (Rs^2) \\ V &= (Rs) \cdot (\omega) / 688 \\ F &= T / Rs \\ E_1 &= (0.186) \cdot (Wa) \cdot (V^2) \\ E_2 &= (F) \cdot (s) \\ E_3 &= E_1 + E_2 \\ E_4 &= (E_3) \cdot (C) \\ We &= E_3 / (0.186) \cdot (V^2) \end{aligned}$$

W = 75 lbs	Wa = (75) • (2 <sup>2</sup> + 4 • 30 <sup>2</sup> ) / (12 • 15 <sup>2</sup> )	= 100.1 lbs
L = 30 inches	V = (15) • (180) / 688	= 3.92 ft/sec
H = 2 inches	F = 9,000 / 15	= 600 lbs
ω = 180°/sec	E <sub>1</sub> = (0.186) • (100.1) • (3.92 <sup>2</sup> )	= 286.1 in lbs
T = 9,000 lbs-in	E <sub>2</sub> = (600) • (1)	= 600 in lbs
Rs = 15 inches	E <sub>3</sub> = 286.1 + 600	= 886.1 in lbs
C = 100/hour	E <sub>4</sub> = (886.1) • (100)	= 88,610 in lbs/h
s = 1 inch	We = 886.1 / (0.186) • (3.92 <sup>2</sup> )	= 310 lbs

R5 - Select from Model Rating Chart: MC 4525-2 or MA 4525

## Rotary Sizing Examples

W = Moving Weight (lbs)  
 H = Thickness of Door or Arm (inches)  
 L = Length of Door or Arm (inches)  
 d = Distance from Pivot to c of g (inches)  
 Rs = Mounting Radius of Shock Absorbers (inches)  
 $\omega$  = Rotational Speed of Weight ( $^{\circ}$ /sec)

T = Propelling Torque (lbs in)  
 $\theta$  = Angle from the Vertical ( $^{\circ}$ )  
 C = Cycles per Hour (/hour)  
 s = Stroke Length of Shock Absorber (inches)  
 F = Propelling Force at Shock Absorber (lbs)

$E_1$  = Kinetic Energy (in lbs)  
 $E_2$  = Propelling Force Energy (in lbs)  
 $E_3$  = Energy per Cycle (in lbs)  
 $E_4$  = Energy per hour (in lbs/hour)  
 We = Effective Weight (lbs)

### R6 Uniform Bar, Vertical Plane

### Examples: Cross-Conveyor Transfer, Gantry Walkway

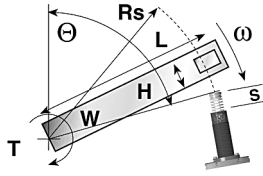

#### FORMULA

$$\begin{aligned} W_a &= (W) \cdot (H^2 + 4 \cdot L^2) / 12 \cdot (R_s^2) \\ V &= (R_s) \cdot (\omega) / 688 \\ F &= [T + 5 \cdot L \cdot W \cdot \sin(\theta)] / R_s \\ E_1 &= (0.186) \cdot (W_a) \cdot (V^2) \\ E_2 &= (F) \cdot (s) \\ E_3 &= E_1 + E_2 \\ E_4 &= (E_3) \cdot (C) \\ W_e &= E_3 / (0.186) \cdot (V^2) \end{aligned}$$

#### EXAMPLE

$$\begin{aligned} W &= 5 \text{ lbs} \\ H &= .25 \text{ inches} \\ L &= 6 \text{ inches} \\ \theta &= 87.6^{\circ} \\ \omega &= 360^{\circ} / \text{sec} \\ T &= 20 \text{ lbs-in} \\ R_s &= 6 \text{ inches} \\ C &= 1,800 / \text{hour} \\ s &= .25 \text{ inches} \end{aligned}$$

$$\begin{aligned} W_a &= (5) \cdot (25^2 + 4 \cdot 6^2) / 12 \cdot (6^2) &= 1.7 \text{ lbs} \\ V &= (6) \cdot (360) / 688 &= 3.1 \text{ ft/sec} \\ F &= [20 + 5 \cdot 6 \cdot 5 \cdot \sin(87.6)] / 6 &= 5.8 \text{ lbs} \\ E_1 &= (0.186) \cdot (1.7) \cdot (3.1^2) &= 3.0 \text{ in lbs} \\ E_2 &= (5.8) \cdot (.25) &= 1.5 \text{ in lbs} \\ E_3 &= 3.3 + 1.5 &= 4.8 \text{ in lbs} \\ E_4 &= (4.5) \cdot (1,800) &= 8,100 \text{ in lbs/hour} \\ W_e &= 4.5 / (0.186) \cdot (3.1^2) &= 2.5 \text{ lbs} \end{aligned}$$

R6 - Select from Model Rating Chart: MC 25L

### R7 Door, Horizontal Plane

### Examples: Cabinet Doors, Machine Enclosures

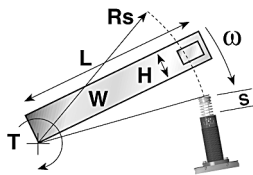

$$\begin{aligned} W_a &= (W) \cdot (H^2 + L^2) / (3 \cdot R_s^2) \\ V &= (R_s) \cdot (\omega) / 688 \\ F &= T / R_s \\ E_1 &= (0.186) \cdot (W_a) \cdot (V^2) \\ E_2 &= (F) \cdot (s) \\ E_3 &= E_1 + E_2 \\ E_4 &= (E_3) \cdot (C) \\ W_e &= E_3 / (0.186) \cdot (V^2) \end{aligned}$$

$$\begin{aligned} W &= 120 \text{ lbs} \\ H &= 1 \text{ inch} \\ L &= 42 \text{ inches} \\ \omega &= 60^{\circ} / \text{sec} \\ T &= 1,800 \text{ lbs-in} \\ R_s &= 10 \text{ inches} \\ C &= 4 / \text{hour} \\ s &= .5 \text{ inches} \end{aligned}$$

$$\begin{aligned} W_a &= (120) \cdot (1^2 + 42^2) / (3 \cdot 10^2) &= 706 \text{ lbs} \\ V &= (10) \cdot (60) / 688 &= .9 \text{ ft/sec} \\ F &= 1,800 / 10 &= 180 \text{ lbs} \\ E_1 &= (0.186) \cdot (706) \cdot (.9^2) &= 106.4 \text{ in lbs} \\ E_2 &= (180) \cdot (.5) &= 90 \text{ in lbs} \\ E_3 &= 106.4 + 90 &= 196.4 \text{ in lbs} \\ E_4 &= (196.4) \cdot (4) &= 785 \text{ in lbs/h} \\ W_e &= 196.4 / (0.186) \cdot (.9^2) &= 1,303.6 \text{ lbs} \end{aligned}$$

R7 - Select from Model Rating Chart: MC 225H2

### R8 Door, Vertical Plane

### Examples: Hatches, Lids, Hoods

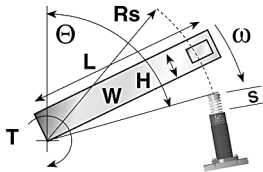

$$\begin{aligned} W_a &= (W) \cdot (H^2 + L^2) / (3 \cdot R_s^2) \\ V &= (R_s) \cdot (\omega) / 688 \\ F^* &= [T + 5 \cdot L \cdot W \cdot \sin(\theta)] / R_s \\ E_1 &= (0.186) \cdot (W_a) \cdot (V^2) \\ E_2 &= (F) \cdot (s) \\ E_3 &= E_1 + E_2 \\ E_4 &= (E_3) \cdot (C) \\ W_e &= E_3 / (0.186) \cdot (V^2) \end{aligned}$$

$$\begin{aligned} W &= 60 \text{ lbs} \\ H &= 1 \text{ inch} \\ L &= 10 \text{ inches} \\ \theta &= 150^{\circ} \\ \omega &= 200^{\circ} / \text{sec} \\ T &= 45 \text{ lbs-in} \\ R_s &= 10 \text{ inches} \\ C &= 1,900 / \text{hour} \\ s &= .63 \text{ inches} \end{aligned}$$

$$\begin{aligned} W_a &= (60) \cdot (1^2 + 10^2) / (3 \cdot 10^2) &= 20.2 \text{ lbs} \\ V &= (10) \cdot (200) / 688 &= 2.9 \text{ ft/sec} \\ F &= [45 + 5 \cdot 10 \cdot 60 \cdot \sin(150)] / 10 &= 19.5 \text{ lbs} \\ E_1 &= (0.186) \cdot (20.2) \cdot (2.9^2) &= 31.6 \text{ in lbs} \\ E_2 &= (19.5) \cdot (0.63) &= 12.3 \text{ in lbs} \\ E_3 &= 34 + 12.3 &= 43.9 \text{ in lbs} \\ E_4 &= (43.9) \cdot (1,900) &= 83,382 \text{ in lbs/h} \\ W_e &= 43.9 / (0.186) \cdot (2.9^2) &= 28.1 \text{ lbs} \end{aligned}$$

\*Force is approximate

R8 - Select from Model Rating Chart: SC 190-2

### R9 Weight at Radius, Horizontal Plane

### Examples: Circuit Breakers, Swinging Gates

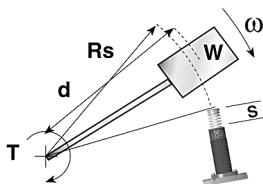

$$\begin{aligned} W_a &= (W) \cdot (d^2) / (R_s^2) \\ V &= (R_s) \cdot (\omega) / 688 \\ F &= T / R_s \\ E_1 &= (0.186) \cdot (W_a) \cdot (V^2) \\ E_2 &= (F) \cdot (s) \\ E_3 &= E_1 + E_2 \\ E_4 &= (E_3) \cdot (C) \\ W_e &= E_3 / (0.186) \cdot (V^2) \end{aligned}$$

$$\begin{aligned} W &= 40 \text{ lbs} \\ d &= 8 \text{ inches} \\ \omega &= 110^{\circ} / \text{sec} \\ T &= 150 \text{ lbs-in} \\ R_s &= 7 \text{ inches} \\ C &= 1,500 / \text{hour} \\ s &= .5 \text{ inches} \end{aligned}$$

$$\begin{aligned} W_a &= (40) \cdot (8^2) / (7^2) &= 52 \text{ lbs} \\ V &= (7) \cdot (110) / 688 &= 1.1 \text{ ft/sec} \\ F &= 150 / 7 &= 21 \text{ lbs} \\ E_1 &= (0.186) \cdot (52) \cdot (1.1^2) &= 11.7 \text{ in lbs} \\ E_2 &= (21) \cdot (.5) &= 10.5 \text{ in lbs} \\ E_3 &= 11.7 + 10.5 &= 22.2 \text{ in lbs} \\ E_4 &= (22.2) \cdot (1,500) &= 33,300 \text{ in lbs/h} \\ W_e &= 22.2 / (0.186) \cdot (1.1^2) &= 98.6 \text{ lbs} \end{aligned}$$

R9 - Select from Model Rating Chart: MC 150H

### R10 Weight at Radius, Vertical Plane

### Examples, Impact Testers, Pendulums

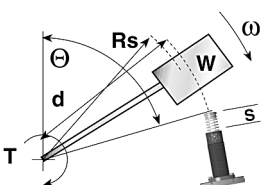

$$\begin{aligned} W_a &= (W) \cdot (d^2) / (R_s^2) \\ V &= (R_s) \cdot (\omega) / 688 \\ F^* &= [T + W \cdot d \cdot \sin(\theta)] / R_s \\ E_1 &= (0.186) \cdot (W_a) \cdot (V^2) \\ E_2 &= (F) \cdot (s) \\ E_3 &= E_1 + E_2 \\ E_4 &= (E_3) \cdot (C) \\ W_e &= E_3 / (0.186) \cdot (V^2) \end{aligned}$$

$$\begin{aligned} W &= 40 \text{ lbs} \\ d &= 8 \text{ inches} \\ \theta &= 90^{\circ} \\ \omega &= 110^{\circ} / \text{sec} \\ T &= 150 \text{ lbs-in} \\ R_s &= 7 \text{ inches} \\ C &= 1,500 / \text{hour} \\ s &= .5 \text{ inches} \end{aligned}$$

$$\begin{aligned} W_a &= (40) \cdot (8^2) / (7^2) &= 52 \text{ lbs} \\ V &= (7) \cdot (110) / 688 &= 1.1 \text{ ft/sec} \\ F &= [150 + 40 \cdot 8 \cdot \sin(90)] / 7 &= 67 \text{ lbs} \\ E_1 &= (0.186) \cdot (52) \cdot (1.1^2) &= 11.7 \text{ in lbs} \\ E_2 &= (67) \cdot (.5) &= 33.5 \text{ in lbs} \\ E_3 &= 11.7 + 33.5 &= 45.2 \text{ in lbs} \\ E_4 &= (45.2) \cdot (1,500) &= 67,800 \text{ in lbs/h} \\ W_e &= 45.2 / (1.1^2) &= 200.8 \text{ lbs} \end{aligned}$$

\*Force is approximate

R10- Select from Model Rating Chart: MC 150H



For inventory, lead times, and kit lookup, visit [www.pdnplu.com](http://www.pdnplu.com)

M11

Parker Hannifin Corporation  
 Pneumatic Division  
 Wadsworth, Ohio  
[www.parker.com/pneumatics](http://www.parker.com/pneumatics)

Industrial Shock Absorbers

M

**1. Shock Absorbers for Pneumatic Cylinders**

- For:
- optimum deceleration
  - higher speeds
  - smaller cylinders
  - reduced air consumption
  - smaller valves and pipework

Example: MA 3350 M-Z  
-Z = cylinder mounting

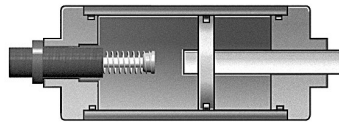

With heavy loads or high velocities normal cylinder cushions are often overloaded. This causes shock loading leading to premature cylinder failure or excessive maintenance.

Using oversized cylinders to withstand this shock loading is not the best solution since this considerably increases air consumption and costs.

**2. Side Load Adapter for High Side Load Angles**

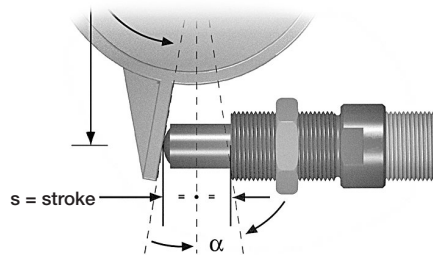

The side loading is removed from the shock absorber piston rod leading to considerably longer life. Wherever possible mount shock absorber so that impacting face is perpendicular to shock absorber axis half way through stroke.

See pages L46 and L47 for more details.

**3. Undamped Free Travel with Damped End Extension**

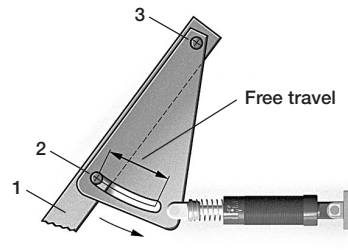

The lever 1 swings with the pin 2 in a slotted hole around pivot point 3. The lever is smoothly decelerated at the extreme end of its travel.

**4. One Shock Absorber for Both Ends of Travel**

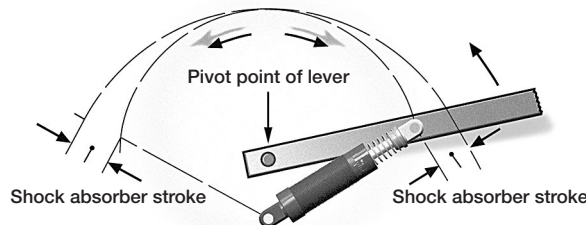

It is possible to use only one shock absorber for both end positions by using different pivot points as shown.

**Tip:** Leave approx. 0.06 in (1.5 mm) of shock absorber stroke free at each end of travel.

**5. Double Acting Shock Absorber**

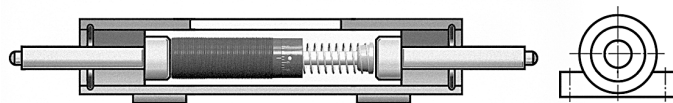

With a little additional work a normal unidirectional shock absorber can be converted to work in 2 directions by using a mechanism as shown.

**6. Air Bleed Collar**

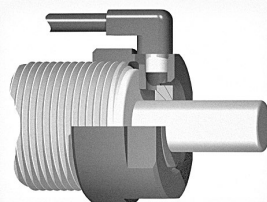

By using this air bleed collar the operating lifetime of shock absorbers in aggressive environments can be considerably increased. The adapter protects the shock absorber seals from cutting fluids, cleaning agents, cooking oils etc. by using a low pressure air bleed.

Available for select shock absorbers.

**7. Double Stroke Length**

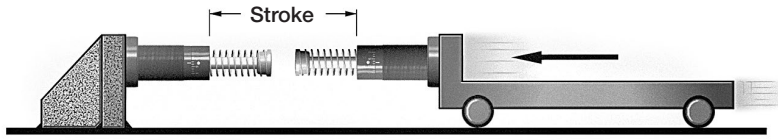

50% lower reaction force (Q) 50% lower deceleration (a)

By driving 2 shock absorbers against one another 'nose-to-nose', the effective stroke length can be doubled.

**8. Ride Over Latch**

8.1



8.2

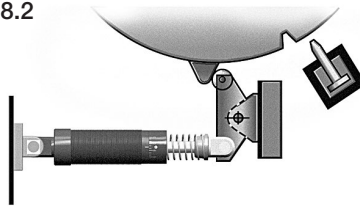

8.1 The latch absorbs the kinetic energy so that the object contacts the fixed stop gently.

8.2 The latch absorbs the rotational energy of the turntable etc. The turntable can then be held in the datum position with a lock bolt or similar device.

**9. Rotary Actuator or Rack and Pinion Drive**

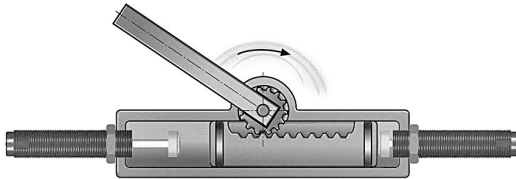

The use of shock absorbers allows higher operating speeds and weights as well as protecting the drive mechanism and housing from shock loads.

**10. Adjustable Stop Clamp e.g. for Handling Equipment**

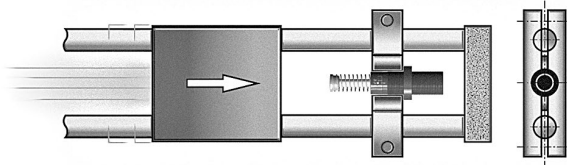

The gentle deceleration of shock absorbers makes the use of adjustable stop clamps possible and removes any chance of the clamp slipping. The kinetic energy is completely removed before the mechanical stop is reached thus making high index speeds possible.

**11. Ride-Over Latch e.g. Fire Door**

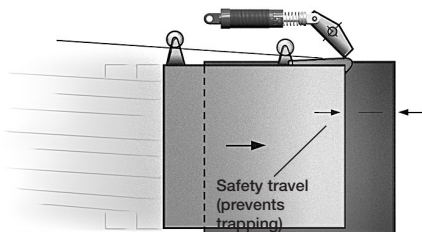

The fire door travels quickly until it reaches the lever. It is then gently decelerated by the lever mounted shock absorber and closes without shock or danger to personnel.

**12. Increasing Stroke Length Mechanically**

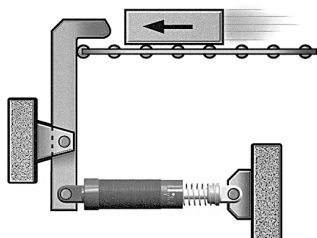

By means of a lever the effective stroke length can be increased and mounting space to the left reduced.

Model Rating Charts

Industrial Shock Absorbers are rated by capacity for the purpose of selecting the proper unit for an application's energy requirements. Ratings are determined by the effective weight that the shock absorber can stop and the energy it can absorb per cycle and per hour. These ratings relate to the mechanical and thermal capacity of a shock absorber because the mechanical energy is converted to heat and dissipated.

Self-Compensating Models

Model Number	Stroke inches 1 inch = 25.4 mm	E3 Max Energy per Cycle, inch lbs 1 in lb = .11 Nm	We Effective Weight lbs, 1 lb = .45 kg	E4 Max Energy per hour, in lbs/hour 1 in lb/hour = .11 Nm/hour			Product Catalog Page
				Self-Contained	A/O Tank	A/O Re-circulating	
MC 9-1	0.20	9	1.35-7.0	18,000	N/A	N/A	L16
MC 9-2	0.20	9	1.75-9.0	18,000			L16
MC 10L	0.20	4	0.75-6.0	35,000	N/A	N/A	L16
MC 10H	0.20	7	1.5-11	35,000			L16
MC 25L	0.25	20	1.5-5	120,000			L16
MC 25	0.25	20	4-12	120,000	N/A	N/A	L16
MC 25H	0.25	20	10-30	120,000			L16
MC 75-1	0.40	75	0.5-2.5	250,000			L16
MC 75-2	0.40	75	2-14	250,000	N/A	N/A	L16
MC 75-3	0.40	75	6-80	250,000			L16
MC 150	0.50	150	2-22	300,000			L18
MC 150H	0.50	150	20-200	300,000	N/A	N/A	L18
MC 150H2	0.50	150	150-450	300,000			L18
MC 225	0.50	225	5-55	400,000			L18
MC 225H	0.50	225	50-500	400,000	N/A	N/A	L18
MC 225H2	0.50	225	400-2,000	400,000			L18
MC 600	1.00	600	20-300	600,000			L18
MC 600H	1.00	600	250-2,500	600,000	N/A	N/A	L18
MC 600H2	1.00	600	880-5,000	600,000			L18
SC 190-1	0.63	225	3-15	300,000			L20
SC 190-2	0.63	225	8-40	300,000	N/A	N/A	L20
SC 190-3	0.63	225	20-100	300,000			L20
SC 190-4	0.63	225	50-225	300,000			L20
SC 300-1	0.75	300	3-18	400,000			L20
SC 300-2	0.75	300	10-60	400,000			L20
SC 300-3	0.75	300	30-180	400,000			L20
SC 300-4	0.75	300	70-450	400,000			L20
SC 300-5	0.59	650	25-100	400,000	N/A	N/A	L22
SC 300-6	0.59	650	75-300	400,000			L22
SC 300-7	0.59	650	200-400	400,000			L22
SC 300-8	0.59	620	300-1,500	400,000			L22
SC 300-9	0.59	620	700-4,300	400,000			L22
SC 650-1	1.00	650	17-100	600,000			L20
SC 650-2	1.00	650	50-300	600,000			L20
SC 650-3	1.00	650	150-900	600,000			L20
SC 650-4	1.00	650	450-2,600	600,000			L20
SC 650-5	0.91	1,860	50-250	600,000	N/A	N/A	L22
SC 650-6	0.91	1,860	200-800	600,000			L22
SC 650-7	0.91	1,860	700-2,400	600,000			L22
SC 650-8	0.91	1,860	1,700-5,800	600,000			L22
SC 650-9	0.91	1,860	4,000-14,000	600,000			L22
SC 925-1	1.58	975	30-200	800,000			L20
SC 925-2	1.58	975	90-600	800,000	N/A	N/A	L20
SC 925-3	1.58	975	250-1,600	800,000			L20
SC 925-4	1.58	975	750-4,600	800,000			L20
MC 3325-1			20-80				
MC 3325-2	0.91	1,350	68-272	670,000	1,100,000	1,500,000	L26, L28
MC 3325-3			230-920				
MC 3325-4			780-3,120				
MC 3350-1			40-160				
MC 3350-2	1.91	2,700	136-544	760,000	1,200,000	1,600,000	L26, L28
MC 3350-3			460-1,840				
MC 3350-4			1,560-6,240				
MC 3625-1			20-80				
MC 3625-2	0.91	1,350	68-272	670,000	1,100,000	1,500,000	L26, L28
MC 3625-3			230-920				
MC 3625-4			780-3,120				
MC 3650-1			40-160				
MC 3650-2	1.91	2,700	136-544	760,000	1,200,000	1,600,000	L26, L28
MC 3650-3			460-1,840				
MC 3650-4			1,560-6,240				
MC 4525-1			50-200				
MC 4525-2	0.91	3,000	170-680	950,000	1,400,000	1,700,000	L26, L30
MC 4525-3			575-2,300				
MC 4525-4			1,950-7,800				
MC 4550-1			100-400				
MC 4550-2	1.91	6,000	340-1,360	1,000,000	1,700,000	2,200,000	L26, L30
MC 4550-3			1,150-4,600				
MC 4550-4			3,900-15,600				
MC 4575-1			150-600				
MC 4575-2	2.91	9,000	510-2,040	1,300,000	2,000,000	2,500,000	L22, L30
MC 4575-3			1,730-6,920				
MC 4575-4			5,850-23,400				
MC 6450-1			300-1,200				
MC 6450-2	1.91	15,000	1,020-4,080	1,300,000	2,600,000	3,400,000	L26, L32
MC 6450-3			3,460-13,840				
MC 6450-4			11,700-46,800				
MC 64100-1			600-2,400				
MC 64100-2	3.91	30,000	2,040-8,160	1,700,000	3,400,000	4,400,000	L26, L32
MC 64100-3			6,920-27,680				
MC 64100-4			23,400-93,600				
MC 64150-1			900-3,600				
MC 64150-2	5.91	45,000	3,060-12,240	2,200,000	4,400,000	5,700,000	L26, L32
MC 64150-3			10,380-41,520				
MC 64150-4			35,100-140,400				

Industrial Shock Absorbers



For inventory, lead times, and kit lookup, visit [www.pdnplu.com](http://www.pdnplu.com)



**Self-Compensating Models Continued**

Model Number	Stroke inches 1 inch = 25.4 mm	E3 Max Energy per Cycle, inch lbs 1 in lb = .11 Nm	We Effective Weight lbs, 1 lb = .45 kg	E4 Max Energy per hour, in lbs/hour 1 in lb/hour = .11 Nm/hour			Product Catalog Page
				Self-Contained	A/O Tank	A/O Re-circulating	
CA 2x2-1 CA 2x2-2 CA 2x2-3 CA 2x2-4	2.00	32,000	1,600-4,800 4,000-12,000 10,000-30,000 25,000-75,000	9,600,000	12,000,000	15,600,000	L38, L40
CA 2x4-1 CA 2x4-2 CA 2x4-3 CA 2x4-4	4.00	64,000	3,200-9,600 8,000-24,000 20,000-60,000 50,000-150,000	12,000,000	15,000,000	19,500,000	L38, L40
CA 2x6-1 CA 2x6-2 CA 2x6-3 CA 2x6-4	6.00	96,000	4,800-14,400 12,000-36,000 30,000-90,000 75,000-225,000	14,400,000	18,000,000	23,500,000	L38, L40
CA 2x8-1 CA 2x8-2 CA 2x8-3 CA 2x8-4	8.00	128,000	6,400-19,200 16,000-48,000 40,000-120,000 100,000-300,000	16,800,000	21,000,000	27,000,000	L38, L40
CA 2x10-1 CA 2x10-2 CA 2x10-3 CA 2x10-4	10.00	160,000	8,000-24,000 20,000-60,000 50,000-150,000 125,000-375,000	19,200,000	24,000,000	31,000,000	L38, L40
CA 3x5-1 CA 3x5-2 CA 3x5-3 CA 3x5-4	5.00	125,000	6,400-19,200 16,000-48,000 40,000-120,000 100,000-300,000	20,000,000	25,000,000	32,500,000	L38, L40
CA 3x8-1 CA 3x8-2 CA 3x8-3 CA 3x8-4	8.00	200,000	10,240-30,720 25,600-76,800 64,000-192,000 160,000-480,000	32,000,000	40,000,000	52,000,000	L38, L40
CA 3x12-1 CA 3x12-2 CA 3x12-3 CA 3x12-4	12.00	300,000	15,360-46,080 38,400-115,200 96,000-288,000 240,000-720,000	48,000,000	60,000,000	78,000,000	L38, L40
CA 4x6-3 CA 4x6-5 CA 4x6-7	6.00 6.00 6.00	420,000 420,000 420,000	8,000-19,000 19,000-41,000 41,000-94,000	27,000,000 27,000,000 27,000,000	45,000,000 45,000,000 45,000,000	58,000,000 58,000,000 58,000,000	L38, L44 L38, L44 L38, L44
CA 4x8-3 CA 4x8-5 CA 4x8-7	8.00 8.00 8.00	560,000 560,000 560,000	11,000-25,000 25,000-55,000 55,000-125,000	30,000,000 30,000,000 30,000,000	50,000,000 50,000,000 50,000,000	65,000,000 65,000,000 65,000,000	L38, L44 L38, L44 L38, L44
CA 4x16-3 CA 4x16-5 CA 4x16-7	16.00 16.00 16.00	1,120,000 1,120,000 1,120,000	22,000-50,000 50,000-110,000 110,000-250,000	50,000,000 50,000,000 50,000,000	85,000,000 85,000,000 85,000,000	110,000,000 110,000,000 110,000,000	L38, L44 L38, L44 L38, L44

**Adjustable Models**

MA 35	0.40	35	13-125	53,000			L24
MA 150	0.50	150	2-200	300,000			L24
MA 225	0.75	225	5-500	400,000	N/A	N/A	L24
MA 600	1.00	600	20-3,000	600,000			L24
MA 900	1.58	900	30-4,500	800,000			L24
MA 3325	0.91	1,500	20-3,800	670,000	1,100,000	1,500,000	L27
MA 3350	1.91	3,000	28-5,400	760,000	1,200,000	1,600,000	L27
MA 3625	0.91	1,500	20-3,800	670,000	1,100,000	1,500,000	L27
MA 3650	1.91	3,000	28-5,400	760,000	1,200,000	1,600,000	L27
MA 4525	0.91	3,450	95-22,000	950,000	1,400,000	1,700,000	L27, L30
MA 4550	1.91	6,900	150-32,000	1,000,000	1,700,000	2,200,000	L27, L30
MA 4575	2.91	10,350	155-33,000	1,300,000	2,000,000	2,500,000	L27, L30
MA 6450	1.91	18,000	480-110,000	1,300,000	2,600,000	3,400,000	L27, L32
MA 64100	3.91	36,000	600-115,000	1,700,000	3,400,000	4,400,000	L27, L32
MA 64150	5.91	54,000	730-175,000	2,200,000	4,400,000	5,700,000	L27, L32
1-1/2x2	2.00	16,000	430-70,000	3,200,000	4,000,000	5,200,000	L36
1-1/2x3-1/2	3.50	28,000	480-80,000	5,600,000	7,000,000	9,100,000	L36
1-1/2x5	5.00	40,000	500-90,000	8,000,000	10,000,000	13,000,000	L36
1-1/2x6-1/2	6.50	52,000	680-100,000	10,400,000	13,000,000	17,000,000	L36
A 2x2	2.00	32,000	560-170,000	9,600,000	12,000,000	15,600,000	L39, L40
A 2x4	4.00	80,000	510-160,000	12,000,000	15,000,000	19,500,000	L39, L40
A 2x6	6.00	120,000	570-190,000	14,400,000	18,000,000	23,500,000	L39, L40
A 2x8	8.00	170,000	580-200,000	16,800,000	21,000,000	27,000,000	L39, L40
A 2x10	10.00	210,000	720-250,000	19,200,000	24,000,000	31,000,000	L39, L40
A 3x5	5.00	140,000	1,050-340,000	20,000,000	25,000,000	32,500,000	L39, L40
A 3x8	8.00	250,000	1,200-400,000	32,000,000	40,000,000	52,000,000	L39, L40
A 3x12	12.00	390,000	1,350-450,000	48,000,000	60,000,000	78,000,000	L39, L40

**Low Velocity Adjustable Models**

ML 3325	0.91	1,500	.05-1.5	670,000	1,100,000	1,500,000	L27
ML 3350	1.91	3,000	.05-1.5	760,000	1,200,000	1,600,000	L27
ML 3625	0.91	1,500	.05-1.5	670,000	1,100,000	1,500,000	L27
ML 3650	1.91	3,000	.05-1.5	760,000	1,200,000	1,600,000	L27
ML 4525	0.91	3,450	.05-1.5	950,000	1,400,000	1,700,000	L27, L30
ML 4550	1.91	6,900	.05-1.5	1,000,000	1,700,000	2,200,000	L27, L30
ML 6425	0.91	9,000	.05-1.5	1,100,000	2,200,000	2,900,000	L27, L32
ML 6450	1.91	18,000	.05-1.5	1,300,000	2,600,000	3,400,000	L27, L32



For inventory, lead times, and kit lookup, visit [www.pdnplu.com](http://www.pdnplu.com)

M15

**Parker Hannifin Corporation**  
Pneumatic Division  
Wadsworth, Ohio  
[www.parker.com/pneumatics](http://www.parker.com/pneumatics)

Industrial Shock Absorbers

**M**

## Miniature Shock Absorbers MC 9 to MC 75 - Self-Compensating

Miniature Shock Absorbers are self-contained hydraulic units. The MC 9 to MC 75 model range has a very short overall length and low return force. Its small size allows for high energy absorption in confined spaces, while the wide effective weight ranges accommodate a variety of load conditions. With threaded outer bodies and multiple accessories, MC models can be mounted in numerous configurations.

**Applications include:**

Small linear slides, material handling and packaging equipment, small robotics, office and medical equipment, as well as instrumentation.



**Operating information**

**Impact velocity range:**

MC 9:	0.5 to 6 ft/sec (0.15 to 1.8 m/sec)
MC 10:	0.5 to 5 ft/sec (0.15 to 1.5 m/sec)
MC 25:	0.5 to 8 ft/sec (0.15 to 2.4 m/sec)
MC 75:	0.5 to 12 ft/sec (0.15 to 3.66 m/sec)

**Operating temperature:**

MC 9 and MC 10:	14°F to 158°F (-10°C to 70°C)
MC 25:	32°F to 150°F (0°C to 66°C)
MC 75:	32°F to 150°F (0°C to 66°C)

**Ordering information – Miniature MC series, self-compensating**

<b>MC</b>	<b>75</b>	<b>-</b>	<b>1</b>	<b>□</b>
MC Series	Model Number	Mounting Thread	Effective Weight	Button Options
	9	MC9	MC9	MC9 & MC10
	10	M M6 x 1.0 Metric	1 Light	Standard, No Button
	25	MC10	2 Medium	-B Acetyl Button
	75	M M8 x 1.0 Metric	MC10	MC25 & MC75
		E M8 x 0.75 Metric	L Light Range	Standard, with Button
		MC25	H Heavy Range	-NB *No Button, Short Rod
		Standard (UNEF)	MC25	-880 No Button, Standard Rod
		M Metric	L Light Range	
		MC75	Standard Range	
		Standard (UNEF)	H Heavy Range	
		M Metric	MC75	
			1 Light	
			2 Medium	
			3 Heavy	

\* Consult factory for dimensional details.

Stroke Inches 1 inch = 25.4 mm	E3 Max. Energy per cycle, inch lbs 1 in lb = .11 Nm	We Effective Weight lbs, 1 lb = .45 kg	E4 Max. Energy Per Hour, in lbs/Hour 1 in lb/Hour = .11 Nm/Hour			Model Number
			Self-Contained	A/O Tank	A/O Re-Circulating	
0.20	9	1.35-7.0	18,000	N/A	N/A	MC 9M-1
0.20	9	1.75-9.0	18,000			MC 9M-2
0.20	4	0.75-6.0	35,000	N/A	N/A	MC 10L
0.20	7	1.5-11	35,000			MC 10H
0.25	20	1.5-5	120,000			MC 25L
0.25	20	4-12	120,000	N/A	N/A	MC 25
0.25	20	10-30	120,000			MC 25H
0.40	75	0.5-2.5	250,000			MC 75-1
0.40	75	2-14	250,000	N/A	N/A	MC 75-2
0.40	75	6-80	250,000			MC 75-3



**Specifications**

- Mechanical stop: Integral mechanical stop built into front of units.
- Oil type – Silicone
- Materials – Steel body with black oxide finish.  
Hardened stainless steel piston rod.
- Technical data applies to standard and metric threaded models.
- Maximum side load depends on application.  
For additional information contact The Pneumatic Division.
- Lock nut included with each shock absorber.

**Note:** All dimensions and tolerance values listed in this catalog are nominal and subject to change without notice.

Model	Return Force lbs (N)	Return Time Sec	Shipping Weight lbs (kg)
<b>MC 9M-1</b> <b>MC 9M-2</b>	0.31 - 0.85 (1.38-3.78)	0.30	0.01 (0.004)
<b>MC 10L</b> <b>MC 10H</b>	0.5 - 1.0 (2.22 - 4.45)	0.20	0.02 (0.01)
<b>MC 25L</b> <b>MC 25</b> <b>MC 25H</b>	0.8 - 1.7 (3.56 - 7.56)	0.20	0.06 (0.03)
<b>MC 75-1</b> <b>MC 75-2</b> <b>MC 75-3</b>	1.0 - 2.5 (4.45 - 11.12)	0.30	0.09 (0.04)

**Miniature Shock Absorbers MC 9 to MC 75**  
Self-Compensating

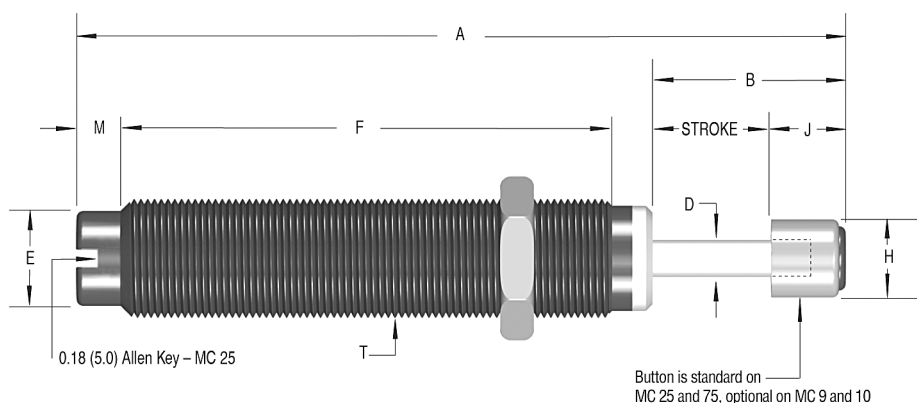

Model	Stroke	A	B	D	E	F	H	J	M	T
<b>MC 9M</b>	.20 (5.0)	1.42 (36.0)	.40 (10.0)	.08 (2.0)	.20 (5.0)	.83 (21.1)	.19 (4.7)	.20 (5.0)	.10 (2.5)	M6x0.5
<b>MC 10E</b> <b>MC 10M</b>	.20 (5.0)	1.52 (38.6)	.40 (10.0)	.08 (2.0)	.25 (6.4)	.83 (21.1)	.19 (4.7)	.20 (5.0)	.19 (4.8)	M8x0.75 M8x1
<b>MC 25</b> <b>MC 25M</b>	.26 (6.6)	2.27 (57.7)	.57 (14.5)	.13 (3.3)	.33 (8.4)	1.3 (33.0)	.30 (7.6)	.32 (8.1)	.20 (5.0)	3/8-32 UNEF M10x1
<b>MC 75</b> <b>MC 75M</b>	.40 (10.2)	2.76 (70.1)	.72 (18.1)	.13 (3.3)	.41 (10.4)	1.74 (44.2)	.30 (7.6)	.32 (8.1)	.18 (4.6)	1/2-20 UNF M12x1

Inches (mm)

Industrial Shock Absorbers



For inventory, lead times, and kit lookup, visit [www.pdnplu.com](http://www.pdnplu.com)

**Miniature Shock Absorbers MC 150 to MC 600 - Self-Compensating**

Miniature Shock Absorbers MC 150 to MC 600 model range, feature a hermetically sealed rolling diaphragm seal system that provides the highest possible cycle lifetime and an extremely low rod return force. These models can be directly mounted into the end cover of pneumatic cylinders to provide superior damping compared to normal cylinder cushions. Use of the optional stop collar is recommended to provide a positive mechanical stop. By adding the optional side load adapter (metric threaded models only), it is possible to accept side loads up to 25° from the axis.

**Applications for the durable MC Series include:**

Material handling, medium robotics, machine tools, pick and place systems, as well as packaging equipment.



**Operating information**

Impact velocity range:	0.26 to 19.7 ft/sec (0.08 to 6 m/sec)
Operating temperature:	32°F to 150°F (0°C to 66°C)

**Note:** MC 150 to MC 600 models may be mounted into pressure chambers of pneumatic actuators.

**Ordering information – Miniature MC series, self-compensating**

<b>MC</b>	<b>225</b>	□	□	□
MC Series	Model Number	Mounting Thread		Effective Weight
	150		Standard (UNF)	<b>MC150, MC225, MC600</b>
	225	<b>M</b>	Metric	Standard Range
	600	<b>ME*</b>	Fine Metric	<b>H</b>
		<b>ML**</b>	Course Metric	<b>H2</b>
				Extra Heavy Range
				Button Options
				Standard, No Button
				<b>-B</b> Acetyl Button
				<b>-BS</b> Steel Button

\*MC 150 only \*\*MC 600 only

Stroke Inches 1 inch = 25.4 mm	E3 Max. Energy Per Cycle, inch lbs 1 in lb = .11 Nm	We Effective Weight lbs, 1 lb = .45 kg	E4 Max. Energy Per Hour, in lbs/hour 1 in lb/Hour = .11 Nm/Hour			Model Number
			Self-Contained	A/O Tank	A/O Re-circulating	
0.50	150	2-22	300,000			<b>MC 150</b>
0.50	150	20-200	300,000	N/A	N/A	<b>MC 150H</b>
0.50	150	150-450	300,000			<b>MC 150H2</b>
0.50	225	5-55	400,000			<b>MC 225</b>
0.50	225	50-500	400,000	N/A	N/A	<b>MC 225H</b>
0.50	225	400-2,000	400,000			<b>MC 225H2</b>
1.00	600	20-300	600,000			<b>MC 600</b>
1.00	600	250-2,500	600,000	N/A	N/A	<b>MC 600H</b>
1.00	600	880-5,000	600,000			<b>MC 600H2</b>

Industrial Shock Absorbers



For inventory, lead times, and kit lookup, visit [www.pdnplu.com](http://www.pdnplu.com)

**Specifications**

- Mechanical stop – Must be provided 0.02 to 0.04 inch (0.5 to 1 mm) before end of stroke.
  - Oil type \_ Silicone
  - Materials –
    - Steel body - with black oxide finish.
    - Piston rod - hardened stainless steel
    - Rolling seal - EPDM
- Note:** seal not compatible with petroleum based fluids. If unit to be used in contact with such fluids specify neoprene rolling seal. Consider the SC2 Series as an alternative.
- To prevent damage to the rolling seal in MC 150, 225 and 600 models, do not twist or turn the piston rod.
  - Technical data applies to standard and metric threaded models.
  - Maximum side load depends on application. For additional information contact The Pneumatic Division.
  - Lock nut included with each shock absorber.

**Note:** MC 150 to MC 600 models may be mounted into pressure chambers of pneumatic actuators.

Model	Return Force lbs (N)	Return Time sec	Shipping Weight lbs (kg)
<b>MC 150</b> <b>MC 150H</b> <b>MC 150H2</b>	0.70 - 1.20 (3.11 - 5.34)	0.40	.12 (0.05)
<b>MC 225</b> <b>MC 225H</b> <b>MC 225H2</b>	1.00 - 1.50 (4.45 - 6.67)	0.30	.34 (0.15)
<b>MC 600</b> <b>MC 600H</b> <b>MC 600H2</b>	1.00 - 2.00 (4.45 - 8.90)	0.60	.57 (0.26)

**Miniature Shock Absorbers MC 150 to MC 600  
Self-Compensating**

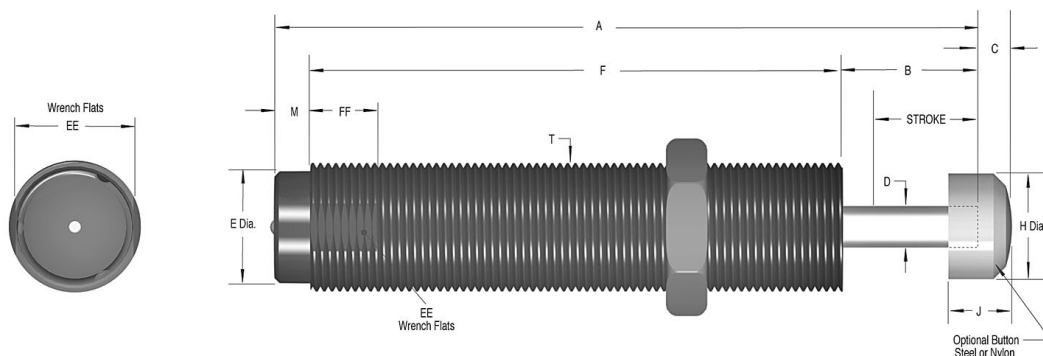

Model	Stroke	A	B	C	D	E	F	H	J	M	T	EE	FF
<b>MC 150</b> <b>MC 150M</b> <b>MC 150ME</b>	.50 (12.8)	3.41 (86.6)	.69 (17.5)	.18 (4.6)	.19 (4.8)	.46 (11.6)	2.44 (62.0)	.47 (11.9)	.39 (9.9)	.28 (7.1)	9/16-18 UNF M14x1.5 M14x1	.500 (12.0)	.50 (12.7)
<b>MC 225</b> <b>MC 225M</b> <b>MC 225ME</b>	.50 (12.8)	3.81 (96.8)	.69 (17.5)	.16 (4.1)	.25 (6.4)	.66 (16.7)	2.84 (72.1)	.66 (16.8)	.36 (9.1)	.28 (7.1)	3/4-16 UNF M20x1.5 M20x1	.687 (18.0)	.50 (12.7)
<b>MC 600</b> <b>MC 600M</b> <b>MC 600ML</b>	1.00 (25.4)	5.58 (141.8)	1.24 (31.6)	.23 (5.8)	.31 (7.9)	.87 (22.0)	4.06 (103.1)	.89 (22.6)	.47 (11.9)	.28 (7.1)	1-12 UNF M25x1.5 M27x3	.875 (23.0)	.50 (12.7)

Inches (mm)

Industrial Shock Absorbers

M



For inventory, lead times, and kit lookup, visit [www.pdnplu.com](http://www.pdnplu.com)

M19

**Parker Hannifin Corporation**  
Pneumatic Division  
Wadsworth, Ohio  
[www.parker.com/pneumatics](http://www.parker.com/pneumatics)

**SC<sup>2</sup> Miniature Series SC 190 to SC 925 - Soft Contact & Self-Compensating**

**SC<sup>2</sup> Series Miniature Shock Absorbers**

provide dual performance benefits. They offer **soft contact deceleration** where initial impact reaction forces are very low, with the advantages of **self-compensation** to react to changing energy conditions, without adjustment. They have long stroke lengths, **SC<sup>2</sup> 925 with 1.58 inch (40 mm) superstroke**, to provide smooth deceleration and low reaction forces.

With the addition of the **optional side load adapter** (SC<sup>2</sup> 190M, 300M, and 650M models only), SC<sup>2</sup> Series shock absorbers can handle side loads up to 25°. SC<sup>2</sup> Series shock absorbers are fully interchangeable with the adjustable MA range.

**Applications include:**

Material handling, medium robotics, machine tools, pick and place systems, rodless cylinders and packaging equipment.



**Operating information**

Impact velocity range:	0.5 to 12 ft/sec (0.15 to 3.66 m/sec)
Operating temperature:	32°F to 150°F (0°C to 66°C)

Note: Integral mechanical stop built into front of units.

**Ordering information – Miniature SC<sup>2</sup> series, soft contact and self-compensating**

<b>SC</b>	<b>300</b>	<b>-</b>	<b>1</b>	
<b>SC<sup>2</sup> Series</b> Soft Contact Self Compensating	<b>Model Number</b> 190 300 650 925	<b>Mounting Thread</b> - Standard (UNF) M Metric	<b>Effective Weight</b> 1 Ultra Light 2 Light 3 Medium 4 Heavy	<b>Button Options</b> - Standard with Button -NB No Button, Short Rod -BS No Button, Standard Rod

Stroke Inches 1 inch = 25.4 mm	E3 Max. Energy Per Cycle, Inch lbs 1 in lb = .11 Nm	We Effective Weight lbs, 1 lb = .45 kg	E4 Max. Energy Per Hour, in lbs/Hour 1 in lb/Hour = .11 Nm/Hour			Model Number
			Self-Contained	A/O Tank	A/O Re-Circulating	
0.63	225	3-15	300,000			SC 190-1
0.63	225	8-40	300,000			SC 190-2
0.63	225	20-100	300,000	N/A	N/A	SC 190-3
0.63	225	50-225	300,000			SC 190-4
0.75	300	3-18	400,000			SC 300-1
0.75	300	10-60	400,000			SC 300-2
0.75	300	30-180	400,000	N/A	N/A	SC 300-3
0.75	300	70-450	400,000			SC 300-4
1.00	650	17-100	600,000			SC 650-1
1.00	650	50-300	600,000			SC 650-2
1.00	650	150-900	600,000	N/A	N/A	SC 650-3
1.00	650	450-2,600	600,000			SC 650-4
1.58	975	30-200	800,000			SC 925-1
1.58	975	90-600	800,000			SC 925-2
1.58	975	250-1,600	800,000	N/A	N/A	SC 925-3
1.58	975	750-4,600	800,000			SC 925-4

**Specifications**

- Mechanical stop – Integral mechanical stop built into front of units.
- Oil type – #5
- Materials – Steel body with black oxide finish. Hardened stainless steel piston rod.
- Technical data applies to standard and metric threaded models.
- Maximum side load depends on application. For additional information contact The Pneumatic Division.
- Lock nut included with each shock absorber.

Model	Return Force lbs (N)	Return Time sec	Shipping Weight lbs (kg)
SC 190-1			
SC 190-2	0.90 - 1.90	0.25	0.18
SC 190-3	(4.00 - 8.95)		(0.08)
SC 190-4			
SC 300-1			
SC 300-2	1.05 - 2.15	0.10	0.25
SC 300-3	(4.67 - 9.56)		(0.11)
SC 300-4			
SC 650-1			
SC 650-2	2.40 - 6.87	0.20	0.67
SC 650-3	(10.67 - 30.55)		(0.31)
SC 650-4			
SC 925-1			
SC 925-2	2.40 - 7.40	0.40	0.87
SC 925-3	(10.67 - 30.55)		(0.39)
SC 925-4			

**SC<sup>2</sup> Series SC 190 to SC 925**

Soft Contact and Self-Compensating

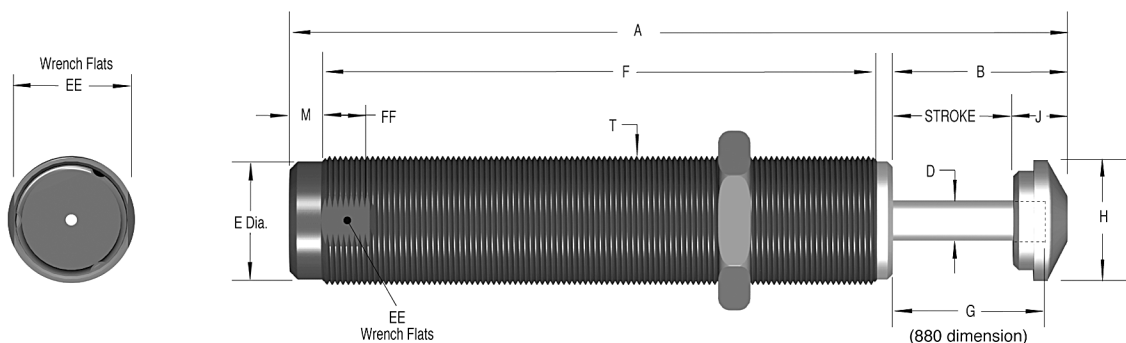

Model	Stroke	A	B	D	E	F	G	H	J	M	T	EE	FF
SC 190	.63	4.50	1.06	.16	.46	3.00	.88	.47	.43	.28	9/16-18 UNF	1/2	.50
SC 190M	(16.0)	(114.3)	(26.9)	(4.1)	(11.7)	(76.2)	(22.4)	(11.9)	(11.0)	(7.1)	M14x1.5	(12.0)	(12.7)
SC 300	.75	4.62	1.18	.19	.66	3.09	1.00	.66	.43	.28	3/4-16 UNF	11/16	.50
SC 300M	(19.1)	(117.5)	(30.0)	(4.8)	(16.8)	(78.5)	(25.4)	(16.8)	(11.0)	(7.1)	M20x1.5	(18.0)	(12.7)
SC 650	1.00	5.62	1.43	.25	.87	3.83	1.25	.90	.43	.28	1-12 UNF	7/8	.50
SC 650M	(25.4)	(142.6)	(36.3)	(6.3)	(22.1)	(97.3)	(31.8)	(22.9)	(11.0)	(7.1)	M25x1.5	(23.0)	(12.7)
SC 925	1.58	7.44	2.01	.25	.87	5.1	1.82	.90	.43	.28	1-12 UNF	7/8	.50
SC 925M	(40.0)	(189.1)	(51.1)	(6.3)	(22.1)	(129.5)	(46.4)	(22.9)	(11.0)	(7.1)	M25x1.5	(23.0)	(12.7)

Inches (mm)

Industrial Shock Absorbers



For inventory, lead times, and kit lookup, visit [www.pdnplu.com](http://www.pdnplu.com)

M21

**Parker Hannifin Corporation**  
 Pneumatic Division  
 Wadsworth, Ohio  
[www.parker.com/pneumatics](http://www.parker.com/pneumatics)

**SC<sup>2</sup> Heavyweight Series SC 300 to SC 650 - Soft Contact & Self-Compensating**

SC<sup>2</sup> 300 and SC<sup>2</sup> 650 Heavyweight Series Shock Absorbers deliver up to 950% of the effective weight capacity and 280% of the energy absorption capability of standard models. These durable units are ideal for decelerating heavy weights moving at low velocities. The Heavyweight Series design combines the piston and the inner tube into a single component, the piston tube. It acts as both the pressure creating and pressure controlling device.

SC<sup>2</sup> 300 and SC<sup>2</sup> 650 Heavyweight II Series Shock Absorbers offer effective weight ranges and dramatic increases in energy absorption capability, for handling a wider range of applications.

These revolutionary shock absorbers provide dual performance benefits. They offer **soft contact** deceleration where initial impact reaction forces are very low with the advantages of **self-compensation** to cope with changing input energy conditions without adjustment.

**Applications include:**

Rotary actuators, rodless cylinders, conveyors, pick and place operations, slides as well as operations turning heavy weights at slow speeds.



**Operating information**

Impact velocity range:	0.3 to 12 ft/sec (0.9 to 3.66 m/sec)
Operating temperature:	32°F to 150°F (0°C to 66°C)

**Note: Integral mechanical stop built into front of units.**

**Ordering information – SC<sup>2</sup> series, soft contact and self compensating**

<b>SC</b>	<b>300</b>	<b>-</b>	<b>5</b>	<b></b>
<b>SC<sup>2</sup> Series</b> Soft Contact Self Compensating	<b>Model Number</b> 300 650	<b>Mounting Thread</b> - Standard (UNF) M Metric	<b>Effective Weight</b> 5 Heavy 6 Heavy Plus 7 Heavy Duty 8 Extra Heavy 9 Ultra Heavy	<b>Button Options</b> Standard with Button -NB No Button, Short Rod -880 No Button, Standard Rod

Stroke Inches 1 inch = 25.4 mm	E3 Max. Energy Per Cycle, Inch lbs 1 in lb = .11 Nm	We Effective Weight lbs, 1 lb = .45 kg	E4 Max. Energy Per Hour, in lbs/Hour 1 in lb/Hour = .11 Nm/Hour			Model Number
			Self-Contained	A/O Tank	A/O Re-Circulating	
0.59	650	25-100	400,000			SC 300-5
0.59	650	75-300	400,000			SC 300-6
0.59	650	200-400	400,000	N/A	N/A	SC 300-7
0.59	620	300-1,500	400,000			SC 300-8
0.59	620	700-4,300	400,000			SC 300-9
0.91	1,860	50-250	600,000			SC 650-5
0.91	1,860	200-800	600,000			SC 650-6
0.91	1,860	700-2,400	600,000	N/A	N/A	SC 650-7
0.91	1,860	1,700-5,800	600,000			SC 650-8
0.91	1,860	4,000-14,000	600,000			SC 650-9

**Specifications**

- Mechanical stop – Integral mechanical stop built into front of units.
- Oil type – #5
- Materials –  
Steel body - with black oxide finish.  
Piston rod - hardened stainless steel
- Technical data applies to standard and metric threaded models.
- Maximum side load depends on application.  
For additional information contact The Pneumatic Division.
- Lock nut included with each shock absorber.

Model	Return Force lbs (N)	Return Time sec	Shipping Weight lbs (kg)
SC 300-5	1.70 - 4.00	0.20	0.33 (0.15)
SC 300-6	(7.56 - 17.79)		
SC 300-7			
SC 300-8	1.70 - 4.00	0.20	0.33 (0.15)
SC 300-9	(7.56 - 17.79)		
SC 650-5	2.40 - 7.30	0.30	0.76 (0.34)
SC 650-6	(10.68 - 32.99)		
SC 650-7			
SC 650-8	2.40 - 7.30	0.30	0.76 (0.34)
SC 650-9	(10.68 - 32.47)		

**SC<sup>2</sup> Heavyweight Series SC 300 to SC 650**  
Soft Contact and Self-Compensating

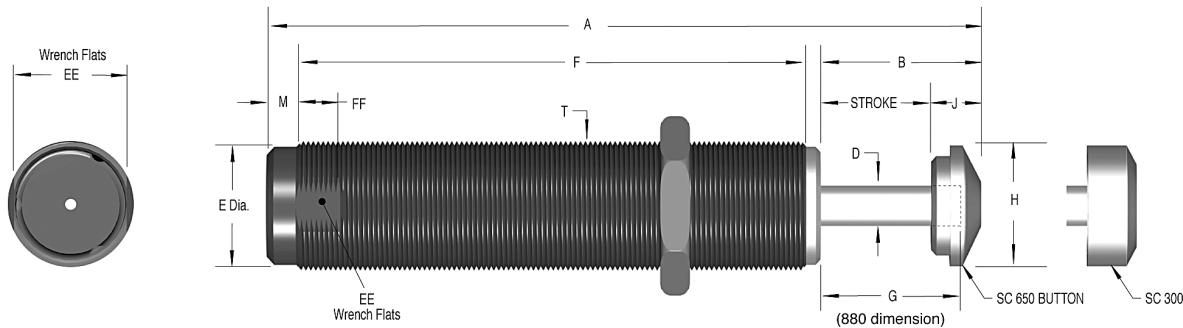

Model	Stroke	A	B	D	E	F	G	H	J	M	T	EE	FF
SC 300-5													
SC 300-6													
SC 300-7													
SC 300-8													
SC 300-9	.59	4.15	1.02	.25	.66	2.78	.84	.67	.43	.28	3/4-16 UNF	11/16	.50
SC 300M-5	(15.0)	(105.4)	(25.9)	(6.4)	(16.8)	(70.6)	(21.3)	(17.0)	(11.0)	(7.1)	M20x1.5	(17.5)	(12.7)
SC 300M-6													
SC 300M-7													
SC 300M-8													
SC 300M-9													
SC 650-5													
SC 650-6													
SC 650-7													
SC 650-8													
SC 650-9	.91	5.51	1.33	.38	.87	3.83	1.16	.88	.43	.28	1-12 UNF	7/8	.50
SC 650M-5	(23.1)	(140.0)	(33.8)	(9.6)	(22.1)	(97.3)	(29.5)	(22.4)	(11.0)	(7.1)	M25x1.5	(22.2)	(12.7)
SC 650M-6													
SC 650M-7													
SC 650M-8													
SC 650M-9													

Inches (mm)

Industrial Shock Absorbers

**M**



For inventory, lead times, and kit lookup, visit [www.pdnplu.com](http://www.pdnplu.com)

M23

**Parker Hannifin Corporation**  
Pneumatic Division  
Wadsworth, Ohio  
[www.parker.com/pneumatics](http://www.parker.com/pneumatics)



**Miniature Shock Absorbers MA 35 to MA 900 - Adjustable**

MA Series miniature shock absorbers offer a compact design with true linear deceleration, and are adjustable over a wide range of conditions. If your preference is a fully adjustable shock absorber rather than a self-compensating model on your application, then the MA Series provides a directly interchangeable alternative.

These adjustable models feature long stroke lengths, **MA 900 with 1.58 inch (40 mm) superstroke**, to provide smooth deceleration and low reaction forces. The MA 150 incorporates the proven rolling diaphragm seal (used on the MC 150 to MC 600 range) and shares all the advantages of that technology.

**Applications include:**

Material handling, medium robotics, pick and place systems, machine tool and packaging equipment.



**Operating information**

Impact velocity range:

MA35	3.3 ft/sec (1.0 m/sec)
MA150, 225, 600, 900	0.5 to 12 ft/sec (0.15 to 3.66 m/sec)

Operating temperature: 32°F to 150°F (0°C to 66°C)

**Ordering information – MA series, adjustable**

<b>MA</b>	<b>225</b>	<b>-</b>	<b>□</b>
<b>MA Series</b> MA – Miniature Adjustable	<b>Model Number</b> 35 150 225 600 900	<b>Mounting Thread</b> - Standard (UNF) M Metric ME Fine Metric (MA 150 Only)	<b>Button Options</b> <b>MA35</b> Standard with Button -NB No Button, Short Rod <b>MA150</b> Standard, No Button -B Nylon Button -BS Steel Button <b>MA 225-900</b> Standard Steel Button -NB No Button, Short Rod -880 No Button, Standard Rod

Stroke Inches 1 inch = 25.4 mm	E3 Max Energy Per Cycle, Inch lbs 1 in lb = .11 Nm	We Effective Weight lbs, 1 lb = .45 kg	E4 Max Energy Per Hour, in lbs/Hour 1 in lb/Hour = .11 Nm/Hour			Model Number
			Self-Contained	A/O Tank	A/O Re-Circulating	
0.40	35	13-125	53,000			<b>MA 35</b>
0.50	150	2-200	300,000			<b>MA 150</b>
0.75	225	5-500	400,000	N/A	N/A	<b>MA 225</b>
1.00	600	20-3,000	600,000			<b>MA 600</b>
1.58	900	30-4,500	800,000	1,100,000 1,200,000	1,500,000 1,600,000	<b>MA 900</b>

## Miniature Shock Absorbers

### Specifications

- Mechanical Stop
- **MA 35** – Integral
- **MA 150** – Must be provided 0.02 to 0.04 inch (0.5 to 1 mm) before end of each stroke.
- **MA 225, 600, 900** – Integral mechanical stop built into front of units.
- Oil type –
  - MA 35 - #5
  - MA 150 - Silicone
  - MA 225, 600, 900 - ATF
- Materials –
  - Steel body - with black oxide finish.
  - Piston rod - hardened stainless steel
- Adjustment –
  - On models MA 35 up to MA 150: by turning the adjustment screw at rear.
  - On the larger sizes: by turning the adjustment knob against the scale marked 0 to 9.
  - After installation, cycle the machine a few times and turn the adjustment knob until optimum deceleration is achieved (i.e. smooth deceleration throughout stroke).
- Hard impact at start of stroke-turn adjuster toward 9.
- Hard set-down at end of stroke-turn adjuster toward 0.

## Industrial Shock Absorbers MA 35 to MA 900 Series, Adjustable

- Technical data applies to standard and metric threaded models.
- Maximum side load depends on application. For additional information contact The Pneumatic Division.
- Lock nut included with each shock absorber.
- MA 35 and MA 150 models can be utilized as velocity controls.

**Note:** MA 150 models may be mounted into pressure chambers of pneumatic actuators.

Model	Return Force lbs (N)	Return Time sec	Shipping Weight lbs (kg)
<b>MA 35</b>	1.20 - 2.60 (5.33 - 11.56)	.17	.10 (0.04)
<b>MA 150</b>	0.70 - 1.20 (3.12 - 5.34)	.40	.12 (0.05)
<b>MA 225</b>	1.05 - 2.15 (4.67 - 9.56)	.10	.28 (0.13)
<b>MA 600</b>	2.40 - 6.87 (10.67 - 30.56)	.20	.67 (0.30)
<b>MA 900</b>	2.40 - 7.40 (10.67 - 32.92)	.40	.87 (0.39)

### Miniature Shock Absorbers MA 35 to MA 900 Adjustable

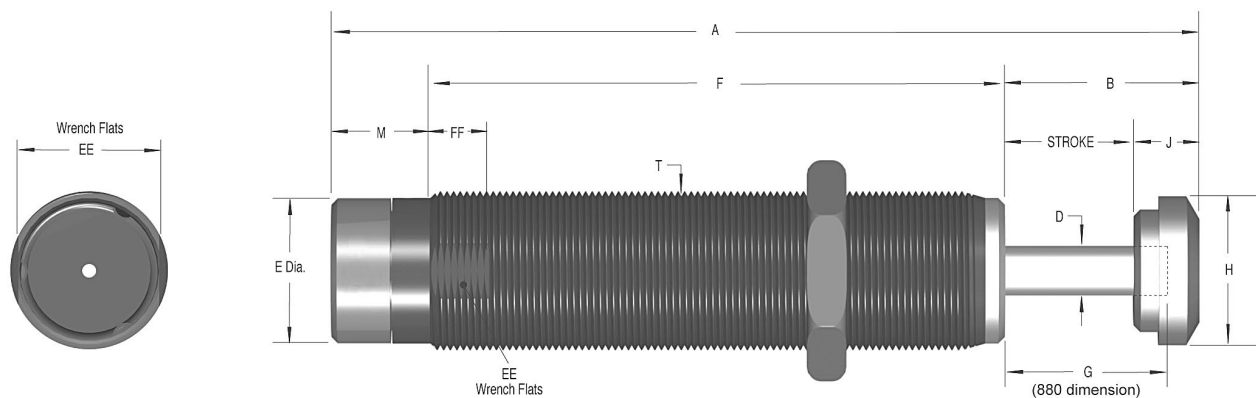

Model	Stroke	A	B	D	E	F	G	H	J	M	T	EE	FF
<b>MA 35</b>	.40	3.31	.72	.13	.42	2.41	N/A	.30	.32	.18	1/2-20 UNF	N/A	N/A
<b>MA 35M</b>	(10.1)	(84.1)	(18.3)	(3.3)	(10.6)	(61.2)		(7.6)	(8.0)	(4.6)	M12x1		
<b>MA 150</b>	.49	3.64	.92	.19	.46	2.44	.69	.47	.43	.28	9/16 - 18 UNF	.49	.50
<b>MA 150M</b>	(12.4)	(92.5)	(23.4)	(4.8)	(11.6)	(62.0)	(17.5)	(11.9)	(11.0)	(7.1)	M14x1.5	(12.7)	(12.7)
<b>MA 150ME</b>											M14x1		
<b>MA 225</b>	.75	4.67	1.18	.19	.66	2.94	1.00	.66	.43	.55	3/4-16 UNF	11/16	.50
<b>MA 225M</b>	(19.1)	(118.6)	(30.0)	(4.8)	(16.8)	(74.7)	(25.3)	(16.8)	(11.0)	(14.0)	M20x1.5	(18.0)	(12.7)
<b>MA 600</b>	1.00	5.62	1.43	.25	.88	3.54	1.25	.90	.43	.65	1-12 UNF	7/8	.50
<b>MA 600M</b>	(25.4)	(142.6)	(36.3)	(6.3)	(22.4)	(90.0)	(31.8)	(22.9)	(11.0)	(16.5)	M25x1.5	(23.0)	(12.7)
<b>MA 900</b>	1.58	7.44	2.01	.25	.88	4.78	1.85	.90	.43	.65	1-12 UNF	7/8	.50
<b>MA 900M</b>	(40.0)	(189.0)	(51.1)	(6.3)	(22.4)	(121.4)	(46.4)	(22.9)	(11.0)	(16.5)	M25x1.5	(23.0)	(12.7)

Inches (mm)



For inventory, lead times, and kit lookup, visit [www.pdnplu.com](http://www.pdnplu.com)

M25

**Parker Hannifin Corporation**  
Pneumatic Division  
Wadsworth, Ohio  
[www.parker.com/pneumatics](http://www.parker.com/pneumatics)

Industrial Shock Absorbers

**M**

**Magnum Series MC 33 to MC 64 - Self-Compensating**

Parker presents the ultimate in industrial shock absorber design...the **Magnum Series**. These versatile performers offer you the capability to mount shock absorbers that contain the highest energy capacity ratings in the industry. **Up to 150% of the energy per cycle** of previous models in the same package size, means increased safety factors in a wider range of applications.

**Up to 390% of the effective weight capacity** of previous models, may allow a smaller, lower priced shock absorber to be mounted, to meet your application requirements.

All Magnum Series shock absorbers are **fully threaded** for ease of installation. **Incorporation of high strength materials** along with an **integral stop collar** translates to extended shock absorber life and cost savings for you.

**Applications include:**

Automotive manufacturing and production equipment, large robotics, heavy conveyors, packaging and glass bottling equipment, rotary actuators, theme park rides, and lumber industry equipment.



**Operating information**

Impact velocity range:	
MC Models:	0.5 to 16.5 ft/sec (0.15 to 5 m/sec)
Operating temperature:	10°F to 150°F (-12°C to 66°C)

**Ordering information – MC series, self compensating**

MC		3325			-		1		C	
<b>Return Method and Accumulator Style</b>		<b>Model Number</b>			<b>Mounting Thread</b>		<b>Effective Weight</b>		<b>Mounting Options</b>	
MC	Self-Contained Spring Return, Internal Accumulator	3325	4525	6450	-	Standard (UNF)	-1	Light Range		Standard Mount
MCA	Air Return, External Accumulator	3350	4550	64100	M	Metric	-2	Medium Range		Flanged Stop Collar
MCS	Spring Return, External Accumulator	3625	4575	64150			-3	Heavy Range		Rectangular Flange*
MCN	Self Return (Clevis), Internal Accumulator	3650					-4	Heavier Range		Square Flange*
									-C	Clevis Mount**
									-S	Side-Foot Mount**
									-P	Side Port
									-Z	Within Air Cylinder

\* Welded versions available upon request.  
 \*\* Not available on MC 3625 and 3650 models.

Stroke Inches 1 inch = 25.4 mm	E3 Max. Energy Per Cycle, inch lbs 1 in lb = .11 Nm	We Effective Weight lbs, 1 lb = .45 kg	E4 Max. Energy Per Hour, in lbs/Hour 1 in lb/Hour = .11 Nm/Hour			Model Number
			Self-Contained	A/O Tank	A/O Re-Circulating	
0.91	1,350	20-80	670,000	1,100,000	1,500,000	MC 3325-1
		68-272				MC 3325-2
		230-920				MC 3325-3
		780-3,120				MC 3325-4
1.91	2,700	40-160	760,000	1,200,000	1,600,000	MC 3350-1
		136-544				MC 3350-2
		460-1,840				MC 3350-3
		1,560-6,240				MC 3350-4
0.91	1,350	20-80	670,000	1,100,000	1,500,000	MC 3625-1
		68-272				MC 3625-2
		230-920				MC 3625-3
		780-3,120				MC 3625-4
1.91	2,700	40-160	760,000	1,200,000	1,600,000	MC 3650-1
		136-544				MC 3650-2
		460-1,840				MC 3650-3
		1,560-6,240				MC 3650-4
0.91	3,000	50-200	950,000	1,400,000	1,700,000	MC 4525-1
		170-680				MC 4525-2
		575-2,300				MC 4525-3
		1,950-7,800				MC 4525-4
1.91	6,000	100-400	1,000,000	1,700,000	2,200,000	MC 4550-1
		340-1,360				MC 4550-2
		1,150-4,600				MC 4550-3
		3,900-15,600				MC 4550-4
2.91	9,000	150-600	1,300,000	2,000,000	2,500,000	MC 4575-1
		510-2,040				MC 4575-2
		1,730-6,920				MC 4575-3
		5,850-23,400				MC 4575-4
1.91	15,000	300-1,200	1,300,000	2,600,000	3,400,000	MC 6450-1
		1,020-4,080				MC 6450-2
		3,460-13,840				MC 6450-3
		11,700-46,800				MC 6450-4
3.91	30,000	600-2,400	1,700,000	3,400,000	4,400,000	MC 64100-1
		2,040-8,160				MC 64100-2
		6,920-27,680				MC 64100-3
		23,400-93,600				MC 64100-4
5.91	45,000	900-3,600	2,200,000	4,400,000	5,700,000	MC 64150-1
		3,060-12,240				MC 64150-2
		10,380-41,520				MC 64150-3
		35,100-140,400				MC 64150-4

**Specifications**

- Oil type – ATF
- Materials –
  - Steel body - with black oxide finish
  - Piston rod - high tensile steel, hardened & chrome plated
  - Rod end button - hardened steel with black oxide finish
  - Return spring - zinc plated
 For optimum heat dissipation, do not paint shock absorber.
- Technical data applies to standard and metric threaded models.
- Lock nut included with each shock absorber.

Model	Return Force lbs (N)	Return Time sec	Shipping Weight lbs (kg)
MC 3325	10.3-19.8 (46-88)	0.03	1.00 (0.45)
MC 3350	9.9-30.3 (44-135)	0.06	1.20 (0.54)
MC 3625	10.3-19.8 (46-88)	0.03	1.23 (0.56)
MC 3650	9.9-30.3 (44-135)	0.06	1.51 (0.68)
MC 4525	15.1-22.8 (67-101)	0.03	2.5 (1.13)
MC 4550	15.1-32.2 (67-143)	0.08	3.0 (1.36)
MC 4575	11.7-40.3 (52-179)	0.11	3.5 (1.59)
MC 6450	20.1-34.9 (89-155)	0.12	6.4 (2.90)
MC 64100	23.5-61 (104-271)	0.34	8.15 (3.70)
MC 64150	16.9-82.2 (75-366)	0.48	11.25 (5.10)



For inventory, lead times, and kit lookup, visit [www.pdnplu.com](http://www.pdnplu.com)

M27

**Parker Hannifin Corporation**  
 Pneumatic Division  
 Wadsworth, Ohio  
[www.parker.com/pneumatics](http://www.parker.com/pneumatics)

Industrial Shock Absorbers

**M**

**Magnum Series MA & ML 33 to 64 - Adjustable**

Magnum Series adjustable shock absorbers feature the latest seal technology, a hardened piston ring, pressure chamber and outer body for increased operating life. Additionally, these rugged units offer the unique feature of front or rear adjustment along with a fully threaded outer body for ease of installation.

Magnum Series adjustable shock absorbers are directly interchangeable with obsolete primary series and competitor models.

Along with the self-compensating models, the adjustable range offers unprecedented increases in energy and effective weight capacity.

**Applications include:**

Automotive manufacturing and production equipment, large robotics, heavy conveyors, packaging and glass bottling equipment, rotary actuators, theme park rides, and lumber industry equipment.



**Operating information**

Impact velocity range:

MA Models 0.5 to 16.5 ft/sec (0.15 to 5 m/sec)

ML Models 0.06 to 1.5 ft/sec (0.02 to 0.46 m/sec)

Operating temperature: 10°F to 150°F (-12°C to 66°C)

**Ordering information – MA & ML (low velocity) series, adjustable**

MA		3325				C	
<b>Return Method and Accumulator Style</b>		<b>Model Number</b>			<b>Mounting Thread</b>		<b>Mounting Options</b>
MA	Self-Contained Spring Return, Internal Accumulator	3325	4525	6450	-	Standard (UNF)	Standard Mount
MAA	Air Return, External Accumulator	3350	4550	64100	M	Metric	Flanged Stop Collar
MAS	Spring Return, External Accumulator	3625	4575	64150			Rectangular Flange*
MAN	Self Return (Clevis), Internal Accumulator	3650					Square Flange*
ML	Self-Contained Spring Return, Internal Accumulator*						-C Clevis Mount**
MLA	Air Return, External Accumulator*						-S Side-Foot Mount***
MLS	Spring Return, External Accumulator*						-P Side Port
MLN	Self Return (Clevis), Internal Accumulator*						-Z Within Air Cylinder

\* Low velocity

\* Welded versions available upon request.

\*\* Not available on ML 3625 and 3650 models.

Stroke Inches 1 inch = 25.4 mm	E3 Max Energy Per Cycle, inch lbs 1 in lb = .11 Nm	We Effective Weight lbs, 1 lb = .45 kg	E4 Max Energy Per Hour, in lbs/Hour 1 in lb/Hour = .11 Nm/Hour			Model Number
			Self-Contained	A/O Tank	A/O Re-Circulating	
0.91	1,500	20-3,800	670,000	1,100,000	1,500,000	MA 3325 MA 3350
1.91	3,000	28-5,400	760,000	1,200,000	1,600,000	
0.91	1,500	20-3,800	670,000	1,100,000	1,500,000	MA 3625 MA 3650
1.91	3,000	28-5,400	760,000	1,200,000	1,600,000	
0.91	3,450	95-22,000	950,000	1,400,000	1,700,000	MA 4525 MA 4550 MA 4575
1.91	6,900	150-32,000	1,000,000	1,700,000	2,200,000	
2.91	10,350	155-33,000	1,300,000	2,000,000	2,500,000	
1.91	18,000	480-110,000	1,300,000	2,600,000	3,400,000	MA 6450 MA 64100 MA 64150
3.91	36,000	600-115,000	1,700,000	3,400,000	4,400,000	
5.91	54,000	730-175,000	2,200,000	4,400,000	5,700,000	
0.91	1,500	.05-1.5	670,000	1,100,000	1,500,000	ML 3325 ML 3350
1.91	3,000	.05-1.5	760,000	1,200,000	1,600,000	
0.91	1,500	.05-1.5	670,000	1,100,000	1,500,000	ML 3625 ML 3650
1.91	3,000	.05-1.5	760,000	1,200,000	1,600,000	
0.91	3,450	.05-1.5	950,000	1,400,000	1,700,000	ML 4525 ML 4550
1.91	6,900	.05-1.5	1,000,000	1,700,000	2,200,000	
0.91	9,000	.05-1.5	1,100,000	2,200,000	2,900,000	ML 6425 ML 6450
1.91	18,000	.05-1.5	1,300,000	2,600,000	3,400,000	

**Specifications**

- Oil type – ATF
- Materials –
  - Steel body - with black oxide finish
  - Piston rod - high tensile steel, hardened & chrome plated
  - Rod end button - hardened steel with black oxide finish
  - Return spring - zinc plated
 For optimum heat dissipation, do not paint shock absorber.
- Adjustment – After installation of the Magnum Series shock absorber, cycle the machine a number of times. Turn the front stop collar or the rear adjuster against the scale marked 0 to 9 until optimum deceleration is achieved (i.e. smooth deceleration throughout the stroke).
- Hard impact at start of stroke-turn adjuster toward 9.
- Hard set-down at end of stroke-turn adjuster toward 0.
- Technical data applies to standard and metric threaded models.
- The Pneumatic Division recommends that side load not exceed 5°. Maximum side load depends on application. For additional information consult The Pneumatic Division.
- Lock nut included with each shock absorber.

Model	Return Force lbs (N)	Return Time sec	Shipping Weight lbs (kg)
MA 3325 ML 3325	10.3-19.8 (46-88)	0.03	1.0 (0.45)
MA 3350 ML 3350	9.9-30.3 (44-135)	0.06	1.2 (0.54)
MA 3625 ML 3625	10.3-19.8 (46-88)	0.03	1.23 (0.56)
MA 3650 ML 3650	9.9-30.3 (44-135)	0.06	1.51 (0.68)
MA 4525 ML 4525	15.1-22.8 (67-101)	0.03	2.5 (1.13)
MA 4550 ML 4550	15.1-32.2 (67-143)	0.08	3.0 (1.36)
MA 4575	11.7-40.3 (52-179)	0.11	3.5 (1.59)
ML 6425	26.7-34.9 (119-155)	0.06	5.5 (2.49)
MA 6450 ML 6450	20.1-34.9 (89-155)	0.12	6.4 (2.90)
MA 64100	23.5-61 (104-271)	0.34	8.15 (3.70)
MA 64150	16.9-82.2 (75-366)	0.48	11.25 (5.10)

**Impact velocity range:**

- MA: 0.5 to 16.5 ft/sec (0.15 to 5 m/sec)
- ML: 0.06 to 1.5 ft/sec (0.02 to 0.46 m/sec)

**Note:** Side load not to exceed 5°. Maximum side load depends on application.



For inventory, lead times, and kit lookup, visit [www.pdnplu.com](http://www.pdnplu.com)



**Magnum Series MC/MA/ML 33, Self-Compensating and Adjustable**

**Primary Mount**



Adjuster (MA and ML only)

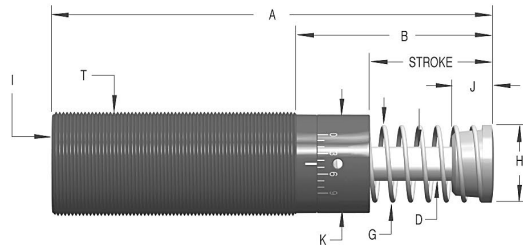

**Clevis Mount**

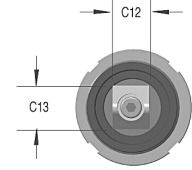
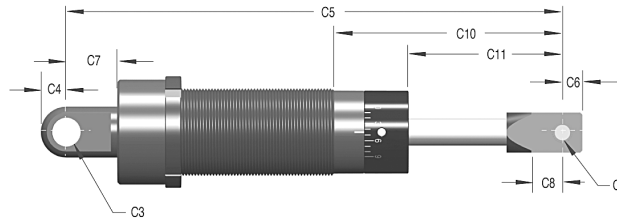
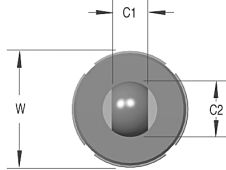

**Side-Foot Mount**

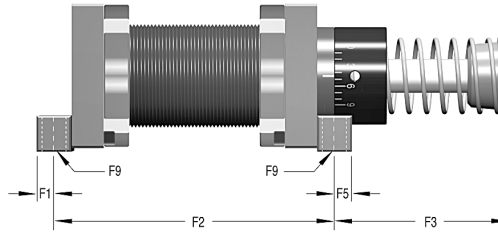
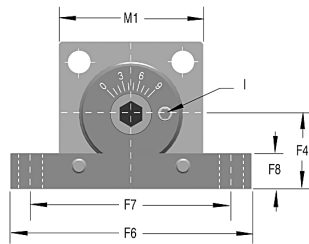

**Magnum Series MC/MA/ML 33 Inches (mm)**

Model	Stroke	A	B	D	G	H	I*	J	K	T	W	C1	C2	C3	C4	C5	C6
3325	0.91 (23.1)	5.44 (138.1)	2.19 (55.6)	0.375 (9.5)	0.99 (25.1)	1.00 (25.4)	1/8 NPT Male	0.75 (19.1)	1.15 (29.2)	1-1/4-12 M33x1.5	1.50 (38.10)	0.50 (12.7)	0.76 (19.3)	.2505 (6.40)	0.32 (8.1)	6.58 (167)	0.25 (6.4)
3350	1.91 (48.5)	7.44 (189)	3.19 (81)	0.375 (9.5)	0.99 (25.1)	1.00 (25.4)	1/8 NPT Male	0.75 (19.1)	1.15 (29.2)	1-1/4-12 M33x1.5	1.56 (39.71)	0.50 (12.7)	0.76 (19.3)	.2505 (6.40)	0.32 (8.1)	8.58 (217.8)	0.25 (6.4)
		C7	C8	C9	C10	C11	C12	C13	F1	F2	F3	F4	F5	F6	F7	F8	F9
3325		0.48 (12.2)	0.50 (12.7)	.2505 (6.4)	2.64 (67.1)	1.36 (34.5)	0.50 (12.7)	0.75 (19.1)	0.25 (6.4)	3.75 (95.3)	1.94 (49.3)	0.87 (22.1)	0.25 (6.4)	2.75 (69.9)	2.37 (60)	0.50 (12.7)	0.23 (5.9)
3350		0.48 (12.2)	0.50 (12.7)	.2505 (6.4)	3.64 (92.5)	2.36 (60)	0.50 (12.7)	0.75 (19.1)	0.25 (6.4)	4.75 (120.7)	2.94 (74.7)	0.87 (22.1)	0.25 (6.4)	2.75 (69.9)	2.37 (60)	0.50 (12.7)	0.23 (5.9)

**Magnum Series MC/MA/ML 36 Inches (mm)**

Model	Stroke	A	B	D	G	H	I*	J	K	T	W
3625	0.91 (23.1)	5.44 (138.1)	2.19 (55.6)	0.375 (9.5)	0.99 (25.1)	1.00 (25.4)	1/8 NPT Male	0.75 (19.1)	1.15 (29.2)	1-3/8-12 M36x1.5	1.75 (44.5)
3650	1.91 (48.5)	7.44 (189)	3.19 (81)	0.375 (9.5)	0.99 (25.1)	1.00 (25.4)	1/8 NPT Male	0.75 (19.1)	1.15 (29.2)	1-3/8-12 M36x1.5	1.75 (44.5)

\* For models MAA and MAS 33 the 1/8-27 male fitting is shipped with the shock.

- Notes:**
1. For models MAA, MLA and MCA indicate P for the side port option when ordering clevis mount.
  2. M36 and 1-3/8 thread is optional.
  3. A side port can be adapted to Magnum Series 33 MAA, MLA and MCA models and is a special adder item. A side port adapter ring is molded onto the outer tube and increases the overall diameter by 0.25 inches (6.3 mm) in the area of the ring. The side port centerline is located 0.81 inches (20.7 mm) from the front of the outer tube. Add (-P) to the model ordering code if a side port is desired.
  4. Poly pad available on 33 models only – part no. 250-0011.
  5. Lock nut included with each shock absorber. See page L48 for dimensions.
  6. All dimensions and tolerance values listed in this catalog are nominal and subject to change without prior notice.



**Magnum Series MC/MA/ML 45, Self-Compensating and Adjustable**

**Primary Mount**



Adjuster (MA and ML only)

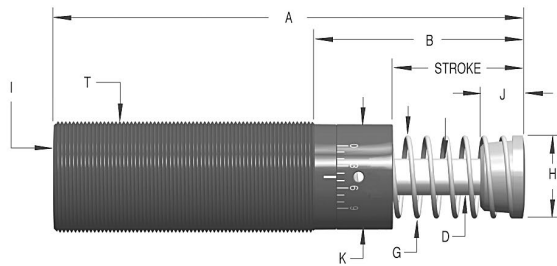

**Clevis Mount**

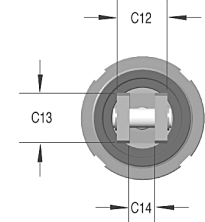
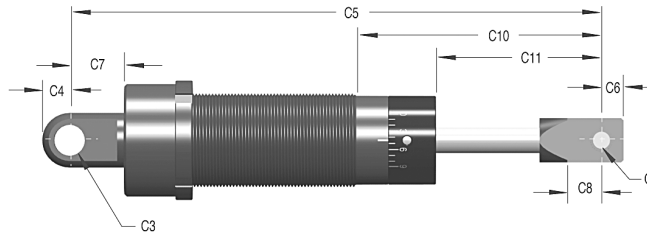
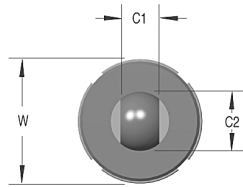

**Side-Foot Mount**

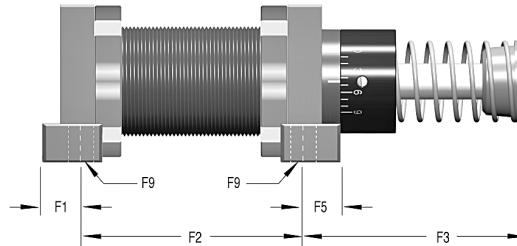
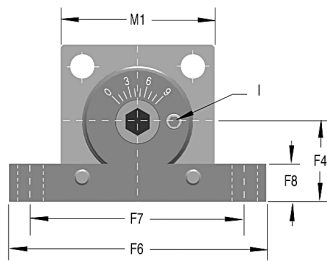

**Magnum Series MC/MA/ML 45 Inches (mm)**

Model	Stroke	A	B	D	G	H	I*	J	K	T	W	C1	C2	C3	C4	C5	C6	
4525	0.91 (23.1)	5.69 (144.5)	1.97 (50)	0.50 (12.7)	1.36 (34.5)	1.38 (34.9)	1/8 NPT	0.87 (22.1)	1.65 (41.9)	1-3/4-12 M45x1.5	2.25 (57.20)	0.75 (19.1)	1.00 (25.4)	.5005 (12.7)	0.50 (12.7)	7.85 (199.4)	0.50 (12.7)	
4550	1.91 (48.5)	7.69 (195.3)	2.97 (75.4)	0.50 (12.7)	1.36 (34.5)	1.38 (34.9)	1/8 NPT	0.87 (22.1)	1.65 (41.9)	1-3/4-12 M45x1.5	2.25 (57.20)	0.75 (19.1)	1.00 (25.4)	.5005 (12.7)	0.50 (12.7)	9.85 (250.2)	0.50 (12.7)	
4575 †	2.91 (73.9)	9.69 (246.1)	3.97 (100.8)	0.50 (12.7)	1.36 (34.5)	1.38 (34.9)	1/8 NPT	0.87 (22.1)	1.65 (41.9)	1-3/4-12 M45x1.5	2.25 (57.20)	0.75 (19.1)	1.00 (25.4)	.5005 (12.7)	0.50 (12.7)	11.85 (301)	0.50 (12.7)	
		C7	C8	C9	C10	C11	C12	C13	C14	F1	F2	F3	F4	F5	F6	F7	F8	F9
4525		1.06 (26.9)	0.69 (17.5)	.3755 (9.6)	2.57 (65.3)	1.51 (38.4)	1.00 (25.4)	1.00 (25.4)	.505 (12.8)	0.50 (12.7)	3.50 (88.9)	1.94 (49.3)	1.16 (29.5)	0.37 (9.5)	3.75 (95.3)	3.00 (76.2)	0.56 (14.2)	0.35 (8.9)
4550		1.06 (26.9)	0.69 (17.5)	.3755 (9.6)	3.57 (90.7)	2.51 (63.8)	1.00 (25.4)	1.00 (25.4)	.505 (12.8)	0.50 (12.7)	4.38 (111.8)	3.06 (77.7)	1.16 (29.5)	0.37 (9.5)	3.75 (95.3)	3.00 (76.2)	0.56 (14.2)	0.35 (8.9)
4575 †		1.06 (26.9)	0.69 (17.5)	.3755 (9.6)	4.57 (116.1)	3.51 (89.2)	1.00 (25.4)	1.00 (25.4)	.505 (12.8)	0.50 (12.7)	5.38 (237.8)	4.06 (103.1)	1.16 (29.5)	0.37 (9.5)	3.75 (95.3)	3.00 (76.2)	0.56 (14.2)	0.35 (8.9)

† Models MC, MA only

\* For models MAA and MAS 45 have pipe plugs.

**Notes:** 1. A side port can be adapted to Magnum Series 45 MAA, MLA and MCA models and is a special adder item. A side port adapter ring is molded onto the outer tube and increases the overall diameter by 0.5 inches (12.7 mm) in the area of the ring. The side port centerline is located 1.04 inches (26.4 mm) from the front of the outer tube. Add (-P) to the model ordering code if a side port is desired.

- 2. Side load not to exceed 5°. Maximum side load depends on application.
- 3. Lock nut included with each shock absorber. See page L48 for dimensions.



For inventory, lead times, and kit lookup, visit [www.pdnplu.com](http://www.pdnplu.com)

M31

**Parker Hannifin Corporation**  
 Pneumatic Division  
 Wadsworth, Ohio  
[www.parker.com/pneumatics](http://www.parker.com/pneumatics)

Industrial Shock Absorbers

**M**

**Magnum Series MC/MA/ML 64, Self-Compensating and Adjustable**

**Primary Mount**



Adjuster (MA and ML only)

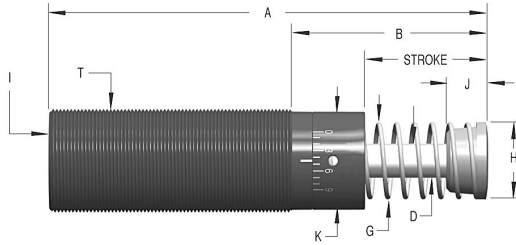

**Clevis Mount**

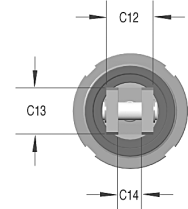
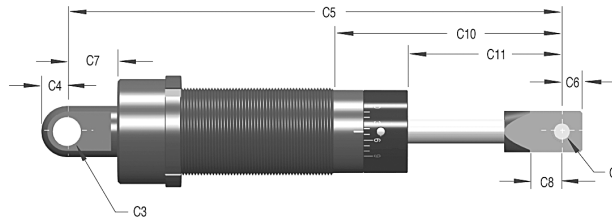
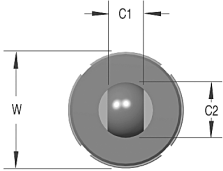

**Side-Foot Mount**

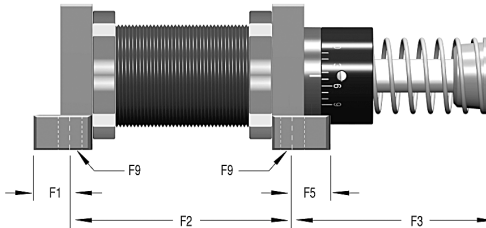
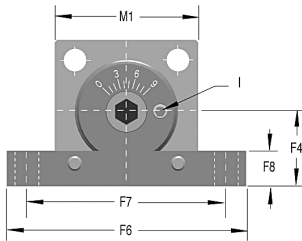

**Magnum Series MC/MA/ML 45 Inches (mm)**

Model	Stroke	A	B	D	G	H	I*	J	K	T	W	C1	C2	C3	C4	C5	C6	
6425 ◊	0.91 (23.1)	6.85 (174)	2.35 (59.7)	0.75 (19.1)	1.86 (47.2)	1.90 (48.3)	1/4 NPT	1.06 (26.9)	2.37 (60.2)	2-1/2-12 M64x2	3.00 (76.20)	1.25 (31.8)	1.50 (38.1)	.7505 (19.1)	0.75 (19.1)	10.12 (257.1)	0.63 (16.0)	
6450	1.91 (48.6)	8.85 (224.8)	3.35 (85.1)	0.75 (19.1)	1.86 (47.2)	1.90 (48.3)	1/4 NPT	1.06 (26.9)	2.37 (60.2)	2-1/2-12 M64x2	3.00 (76.20)	1.25 (31.8)	1.50 (38.1)	.7505 (19.1)	0.75 (19.1)	12.12 (307.9)	0.63 (16.0)	
64100 †	3.91 (99.4)	12.85 (326.4)	5.35 (135.9)	0.75 (19.1)	1.86 (47.2)	1.90 (48.3)	1/4 NPT	1.06 (26.9)	2.37 (60.2)	2-1/2-12 M64x2	3.00 (76.20)	1.25 (31.8)	1.50 (38.1)	.7505 (19.1)	0.75 (19.1)	16.12 (409.5)	0.63 (16.0)	
64150 †	5.91 (150.1)	17.73 (450.4)	8.23 (209)	0.75 (19.1)	2.31 (58.7)	2.38 (60.3)	1/4 NPT	1.25 (31.8)	2.37 (60.2)	2-1/2-12 M64x2	3.00 (76.20)	1.25 (31.8)	1.50 (38.1)	.7505 (19.1)	0.75 (19.1)	20.87 (530.1)	0.63 (16.0)	
64150 ‡	5.91 (150.1)	17.60 (447)	8.10 (205.7)	0.75 (19.1)	-	1.90 (48.3)	1/4 NPT	1.06 (26.9)	2.37 (60.2)	2-1/2-12 M64x2	-	-	-	-	-	-	-	
		C7	C8	C9	C10	C11	C12	C13	C14	F1	F2	F3	F4	F5	F6	F7	F8	F9
6425 ◊		1.29 (32.8)	1.40 (35.6)	.7505 (19.1)	3.75 (95.2)	2.31 (58.7)	1.50 (38.1)	1.25 (31.8)	.625 (15.9)	0.69 (17.5)	4.00 (101.6)	2.56 (65.0)	1.78 (45.2)	0.69 (17.5)	5.62 (142.8)	4.88 (124.0)	0.75 (19.1)	0.42 (10.7)
6450		1.29 (32.8)	1.40 (35.6)	.7505 (19.1)	4.75 (120.7)	3.31 (84.1)	1.50 (38.1)	1.25 (31.8)	.625 (15.9)	0.69 (17.5)	5.00 (127.0)	3.56 (90.4)	1.78 (45.2)	0.69 (17.5)	5.62 (142.8)	4.88 (124.0)	0.75 (19.1)	0.42 (10.7)
64100 †		1.29 (32.8)	1.40 (35.6)	.7505 (19.1)	6.75 (171.5)	5.31 (134.9)	1.50 (38.1)	1.25 (31.8)	.625 (15.9)	0.69 (17.5)	7.00 (177.8)	5.56 (141.2)	1.78 (45.2)	0.69 (17.5)	5.62 (142.8)	4.88 (124.0)	0.75 (19.1)	0.42 (10.7)
64150 †		1.29 (32.8)	1.40 (35.6)	.7505 (19.1)	9.50 (241.3)	8.06 (204.7)	1.50 (38.1)	1.25 (31.8)	.625 (15.9)	0.69 (17.5)	9.00 (228.6)	8.44 (214.4)	1.78 (45.2)	0.69 (17.5)	5.62 (142.8)	4.88 (124.0)	0.75 (19.1)	0.42 (10.7)
64150 ‡		-	-	-	-	-	-	-	.625 (15.9)	0.69 (17.5)	-	8.31 (211.1)	1.78 (45.2)	0.69 (17.5)	5.62 (142.8)	4.88 (124.0)	0.75 (19.1)	0.42 (10.7)

◊ Model ML only.

† Models MC, MA only.

‡ Models MCA, MAA only.

\* For models MAA and MAS 64 have pipe plugs.

- Notes:**
1. A side port can be adapted to Magnum Series 64 MAA, MLA and MCA models and is a special adder item. A side port adapter ring is molded onto the outer tube and increases the overall diameter by 0.5 inches (12.7 mm) in the area of the ring. The side port centerline is located 1.47 inches (37.3 mm) from the front of the outer tube. Add (-P) to the model ordering code if a side port is desired.
  2. MA and MC 64150 models include an integral, non-removable stop block, not a stop collar. Adjustable models can be adjusted from front or rear.
  3. MAA and MCA 64150 models include a stop collar, 0.75 inches (19 mm) longer than the standard 64 model stop collar.
  4. For models MAA, MLA and MCA indicate P for the side port option when ordering clevis mount.
  5. 64150 models do not include a stop collar. Adjustable models can still be adjusted from front or rear.
  6. Side load not to exceed 5°. Maximum side load depends on application.
  7. Lock nut included with each shock absorber. See page L48 for dimensions.

## 1-1/2" Bore Series - Adjustable

1-1/2" bore series shock absorbers are designed for the toughest environments. These durable adjustable models provide outstanding deceleration over a wide range of effective weight conditions. Large energy capacities stop heavy loads set into motion by high propelling forces, without damage.

**Applications include:**

Automotive manufacturing and production equipment, large robotics, heavy conveyors, foundries and steel industry equipment.



### Operating information

Impact velocity range:	0.5 to 15 ft/sec (0.15 to 4.5 m/sec)
Operating temperature:	10°F to 150°F (-12°C to 66°C)

### Ordering information – 1-1/2" bore series, adjustable

<b>A</b>	<b>1-1/2</b>	<b>6-1/2</b>	<b>F</b>
<b>Return Method and Accumulator Style</b>	<b>Bore Size</b>	<b>Stroke Length</b>	<b>Mounting Style</b>
<b>A</b> Spring Return, Internal Accumulator	<b>1-1/2</b>	<b>2</b>	<b>-F</b> Front Flange
<b>AA</b> Air Return, External Accumulator		<b>3-1/2</b>	<b>-R</b> Rear Flange
<b>SA</b> Spring Return, External Accumulator		<b>5</b>	<b>-RF</b> Front Rectangular Flange
<b>NA</b> Self Return (Clevis), Internal Accumulator		<b>6-1/2</b>	<b>-RR</b> Rear Rectangular Flange
			<b>-S</b> Side Foot Mount
			<b>-C</b> Clevis Mount

Stroke Inches 1 inch = 25.4 mm	E3 Max Energy Per Cycle, inch lbs 1 in lb = .11 Nm	We Effective Weight lbs, 1 lb = .45 kg	E4 Max Energy Per Hour, in lbs/Hour 1 in lb/Hour = .11 Nm/Hour			Model Number
			Self-Contained	A/O Tank	A/O Re-Circulating	
2.00	16,000	430-70,000	3,200,000	4,000,000	5,200,000	1-1/2x2
3.50	28,000	480-80,000	5,600,000	7,000,000	9,100,000	1-1/2x3-1/2
5.00	40,000	500-90,000	8,000,000	10,000,000	13,000,000	1-1/2x5
6.50	52,000	680-100,000	10,400,000	13,000,000	17,000,000	1-1/2x6-1/2

### Specifications

- Mechanical stop – must be provided .09 inch (2.3 mm) before end of stroke.
- Oil type – American 46
- Materials –
  - Steel body - with black oxide finish
  - Piston rod - high tensile steel, hardened & chrome plated
  - Return spring - zinc plated
- Adjustment – after installation of the shock absorber, cycle the machine a number of times. Turn the adjustment ring against the scale marked 0 to 9, until optimum deceleration is achieved (i.e. smooth deceleration throughout the stroke).

- Hard impact at the start of stroke-turn adjuster toward 9
- Hard set-down at the end of stroke-turn adjuster toward 0
- Poly pad – Optional

Model	Return Force lbs (N)	Return Time sec	Shipping Weight lbs (kg)
1-1/2 x 2	34.9 - 47.6 (155 - 210)	.10	16.4 (7.44)
1-1/2 x 3-1/2	25.4 - 47.6 (113-210)	.25	19.4 (8.80)
1-1/2 x 5	20.7 - 52.5 (92 - 230)	.40	22.7 (10.30)
1-1/2 x 6-1/2	20.7 - 97.4 (92 - 430)	.40	25.0 (11.34)



For inventory, lead times, and kit lookup, visit [www.pdnplu.com](http://www.pdnplu.com)

M33

Parker Hannifin Corporation  
Pneumatic Division  
Wadsworth, Ohio  
[www.parker.com/pneumatics](http://www.parker.com/pneumatics)

Industrial Shock Absorbers

M

**1-1/2" Bore Series, Adjustable**

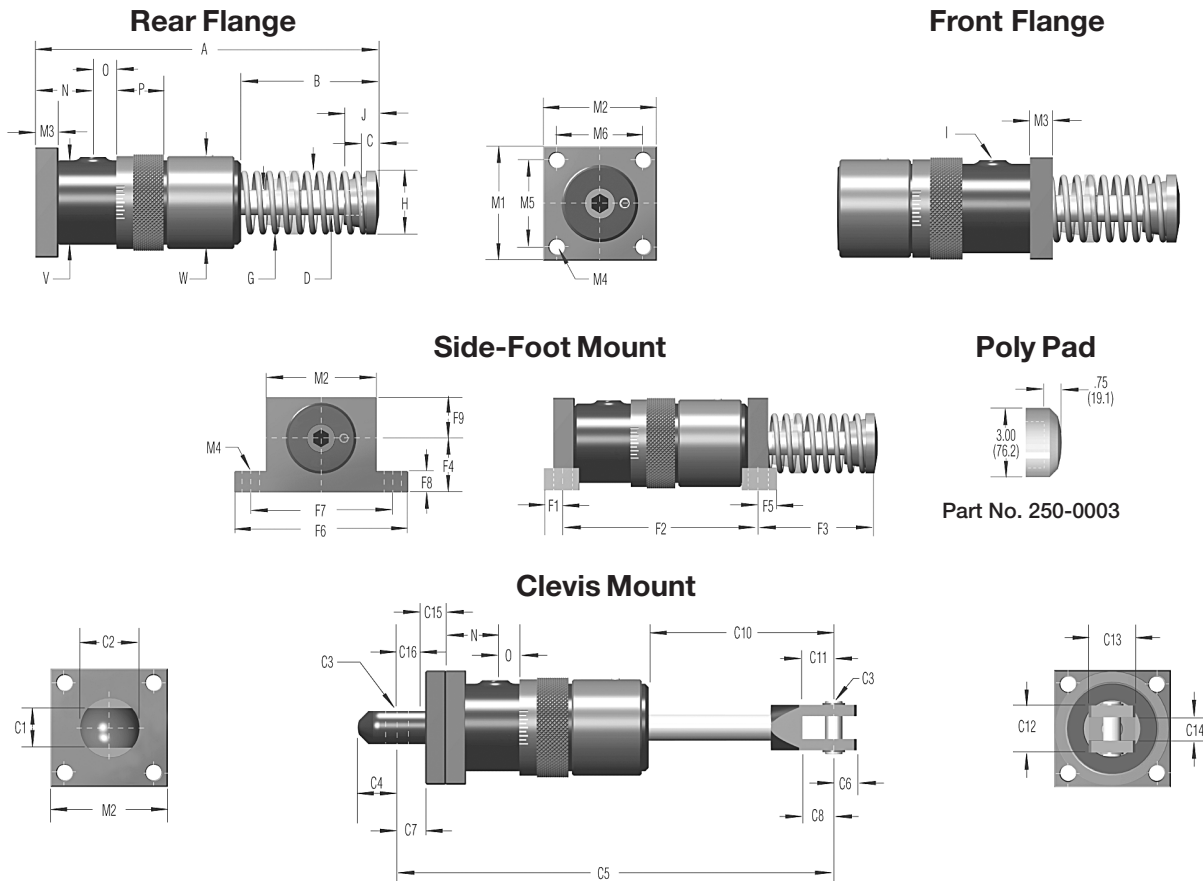

**1-1/2" Bore Series Dimensions Inches (mm)**

Model	Stroke	A	B	CC	D	G	H	I	J	N	O	P	V	W	C1	C2	
1-1/2 x 2	2.00 (50.8)	9.69 (246.1)	4.13 (104.8)	0.81 (20.6)	1.00 (25.4)	2.69 (68.3)	2.75 (69.9)	1/2 NPT	1.38 (35.1)	1.38 (35.0)	0.28 (7.1)	1.25 (31.8)	3.00 (76.2)	4.00 (101.6)	1.25 (31.8)	1.50 (38.1)	
1-1/2 x 3-1/2	3.50 (88.9)	12.69 (322.3)	5.63 (142.9)	0.81 (20.6)	1.00 (25.4)	2.69 (68.3)	2.75 (69.9)	1/2 NPT	1.38 (35.1)	2.00 (50.8)	0.28 (7.1)	1.25 (31.8)	3.00 (76.2)	4.00 (101.6)	1.25 (31.8)	1.50 (38.1)	
1-1/2 x 5	5.00 (127.0)	15.69 (398.5)	7.13 (181.0)	0.81 (20.6)	1.00 (25.4)	2.69 (68.3)	2.75 (69.9)	1/2 NPT	1.38 (35.1)	2.00 (50.8)	1.03 (26.2)	1.25 (31.8)	3.00 (76.2)	4.00 (101.6)	1.25 (31.8)	1.50 (38.1)	
1-1/2 x 6-1/2	6.50 (165.1)	19.44 (493.7)	9.38 (238.1)	0.81 (20.6)	1.00 (25.4)	2.69 (68.3)	2.75 (69.9)	1/2 NPT	1.38 (35.1)	2.00 (50.8)	1.78 (45.2)	1.25 (31.8)	3.00 (76.2)	4.00 (101.6)	1.25 (31.8)	1.50 (38.1)	
		<b>C3</b>	<b>C4</b>	<b>C5</b>	<b>C6</b>	<b>C7</b>	<b>C8</b>	<b>C10</b>	<b>C11</b>	<b>C12</b>	<b>C13</b>	<b>C14</b>	<b>C15</b>	<b>C16</b>	<b>F1</b>	<b>F2</b>	<b>F3</b>
1-1/2 x 2	0.7525 (19.11)	0.75 (19.1)	12.94 (328.6)	0.63 (16.0)	1.25 (31.8)	1.41 (35.7)	5.41 (137.3)	1.40 (35.6)	1.50 (38.1)	1.25 (31.8)	5/8	0.94 (23.9)	1.06 (27.0)	0.63 (15.9)	† 5.18 (131.6)	† 4.31 (109.5)	
1-1/2 x 3-1/2	0.7525 (19.11)	0.75 (19.1)	15.97 (405.6)	0.63 (16.0)	1.25 (31.8)	1.41 (35.7)	6.91 (175.4)	1.40 (35.6)	1.50 (38.1)	1.25 (31.8)	5/8	0.94 (23.9)	1.06 (27.0)	0.63 (15.9)	6.69 (169.9)	5.81 (147.6)	
1-1/2 x 5	0.7525 (19.11)	0.75 (19.1)	18.97 (481.8)	0.63 (16.0)	1.25 (31.8)	1.41 (35.7)	8.41 (213.5)	1.40 (35.6)	1.50 (38.1)	1.25 (31.8)	5/8	0.94 (23.9)	1.06 (27.0)	0.63 (15.9)	8.19 (208.0)	7.31 (185.7)	
1-1/2 x 6-1/2	0.7525 (19.11)	0.75 (19.1)	22.72 (577.1)	0.63 (16.0)	1.25 (31.8)	1.41 (35.7)	10.66 (270.7)	1.40 (35.6)	1.50 (38.1)	1.25 (31.8)	5/8	0.94 (23.9)	1.06 (27.0)	0.63 (15.9)	9.69 (246.1)	9.56 (242.8)	
		<b>F4</b>	<b>F5</b>	<b>F6</b>	<b>F7</b>	<b>F8</b>	<b>F9</b>	<b>M1</b>	<b>M2</b>	<b>M3</b>	<b>M4</b>	<b>M5</b>	<b>M6</b>				
1-1/2 x 2	2.00 (50.8)	0.63 (16.0)	6.50 (165.1)	5.50 (139.7)	0.75 (19.1)	2.03 (51.6)	4.00 (101.6)	4.00 (101.6)	0.75 (19.0)	0.53 (13.5)	3.00 (76.2)	3.00 (76.2)					
1-1/2 x 3-1/2	2.00 (50.8)	0.63 (16.0)	6.50 (165.1)	5.50 (139.7)	0.75 (19.1)	2.03 (51.6)	4.00 (101.6)	4.00 (101.6)	0.75 (19.0)	0.53 (13.5)	3.00 (76.2)	3.00 (76.2)					
1-1/2 x 5	2.00 (50.8)	0.63 (16.0)	6.50 (165.1)	5.50 (139.7)	0.75 (19.1)	2.03 (51.6)	∅	4.00 (101.6)	0.75 (19.0)	0.53 (13.5)	∅	3.00 (76.2)					
1-1/2 x 6-1/2	2.00 (50.8)	0.63 (16.0)	6.50 (165.1)	5.50 (139.7)	0.75 (19.1)	2.03 (51.6)	5.00 (127.0)	4.00 (101.6)	0.75 (19.0)	0.53 (13.5)	4.00 (101.6)	3.00 (76.2)					

∅ Rectangular flange dimension

† Note: 1-1/2 x 2 shock absorbers available with side-foot mount in AA and SA models only.

## Heavy Industrial Shock Absorbers CA 2 to CA 3 - Self-Compensating

CA 2" & CA 3" Bore Series of self-compensating shock absorbers are designed for extremely heavy duty applications and provide smooth deceleration under changing conditions. High energy capacities combined with wide effective weight ranges qualify these units to perform in the most demanding environments.

The new CA 2 offers up to 170% of the energy per cycle capacity of former models. The rugged new CA 3 offers up to 125% of the energy capacity of former models. Replacing existing shock absorbers with the new CA Series is easy-just provide us the type and adjustment setting of your existing units and we will, do the rest. These dependable units are available self-contained or for use with an external air/oil tank.

**Applications include:**

Foundry, steel, marine, lumber and other heavy equipment industries.



**Operating information**

Impact velocity range:	1 to 16.5 ft/sec (0.30 to 5 m/sec)
Operating temperature:	10°F to 150°F (-12°C to 66°C)

**Ordering information – CA 2 & CA 3 series, self-compensating**

<b>CA</b>		<b>2</b>	x	<b>8</b>	<b>R</b>	-	<b>3</b>	
<b>Return Method and Accumulator Style</b>		<b>Bore Size</b>		<b>Stroke Length</b>	<b>Mounting Style</b>		<b>Effective Weight</b>	
<b>CA</b>	Spring Return, Internal Accumulator	<b>2</b>		2	<b>-F</b>	Front Flange	<b>-1</b>	Light
<b>CAA</b>	Air Return, External Accumulator	<b>3</b>		4	<b>-R</b>	Rear Flange	<b>-2</b>	Medium Light
<b>CSA</b>	Spring Return, External Accumulator			5	<b>-RF</b>	Front Rectangular Flange	<b>-3</b>	Medium Heavy
<b>CNA</b>	Self Return (Clevis), Internal Accumulator			6	<b>-RR</b>	Rear Rectangular Flange	<b>-4</b>	Heavy
				8	<b>-S</b>	Side Foot Mount		
				10	<b>-C</b>	Clevis Mount		
				12				

Stroke Inches 1 inch = 25.4 mm	E3 Max Energy Per Cycle, Inch lbs 1 in lb = .11 Nm	We Effective Weight lbs, 1 lb = .45 kg	E4 Max Energy Per Hour, in lbs/Hour 1 in lb/Hour = .11 Nm/Hour			Model Number
			Self-Contained	A/O Tank	A/O Re-Circulating	
2.00	32,000	1,600-4,800 4,000-12,000 10,000-30,000 25,000-75,000	9,600,000	12,000,000	15,600,000	CA 2x2-1 CA 2x2-2 CA 2x2-3 CA 2x2-4
4.00	64,000	3,200-9,600 8,000-24,000 20,000-60,000 50,000-150,000	12,000,000	15,000,000	19,500,000	CA 2x4-1 CA 2x4-2 CA 2x4-3 CA 2x4-4
6.00	96,000	4,800-14,400 12,000-36,000 30,000-90,000 75,000-225,000	14,400,000	18,000,000	23,500,000	CA 2x6-1 CA 2x6-2 CA 2x6-3 CA 2x6-4
8.00	128,000	6,400-19,200 16,000-48,000 40,000-120,000 100,000-300,000	16,800,000	21,000,000	27,000,000	CA 2x8-1 CA 2x8-2 CA 2x8-3 CA 2x8-4
10.00	160,000	8,000-24,000 20,000-60,000 50,000-150,000 125,000-375,000	19,200,000	24,000,000	31,000,000	CA 2x10-1 CA 2x10-2 CA 2x10-3 CA 2x10-4
5.00	125,000	6,400-19,200 16,000-48,000 40,000-120,000 100,000-300,000	20,000,000	25,000,000	32,500,000	CA 3x5-1 CA 3x5-2 CA 3x5-3 CA 3x5-4
8.00	200,000	10,240-30,720 25,600-76,800 64,000-192,000 160,000-480,000	32,000,000	40,000,000	52,000,000	CA 3x8-1 CA 3x8-2 CA 3x8-3 CA 3x8-4
12.00	300,000	15,360-46,080 38,400-115,200 96,000-288,000 240,000-720,000	48,000,000	60,000,000	78,000,000	CA 3x12-1 CA 3x12-2 CA 3x12-3 CA 3x12-4

**Specifications**

- Mechanical stop – 2", 3" bore:  
must be provided .09 inch (2.3 mm) before end of stroke
- Oil type – ATF
- Materials –  
Steel body - with black oxide finish  
Piston rod - high tensile steel, hardened & chrome plated  
Rod end button - hardened steel with black oxide finish  
Return spring - zinc plated

Model	Return Force lbs (N)	Return Time sec	Shipping Weight lbs (kg)
CA 2 x 2	48-63 (214-280)	0.25	28.2 (12.79)
CA 2 x 4	34-63 (151-280)	0.50	32.6 (14.79)
CA 2 x 6	34-90 (151-400)	0.60	37.2 (16.87)
CA 2 x 8	51-144 (227-641)	0.70	42.6 (19.32)
CA 2 x 10	35-101 (156-449)	0.80	50.2 (22.77)
CA 3 x 5	59-156 (262-694)	0.60	63.8 (28.94)
CA 3 x 8	62-162 (275-721)	0.80	73.6 (33.38)
CA 3 x 12	60-160 (267-712)	1.20	89.4 (40.55)

Industrial Shock Absorbers



For inventory, lead times, and kit lookup, visit [www.pdnplu.com](http://www.pdnplu.com)

M36

**Parker Hannifin Corporation**  
Pneumatic Division  
Wadsworth, Ohio  
[www.parker.com/pneumatics](http://www.parker.com/pneumatics)

**CA 2, CA 3 Bore Series – Heavy Duty Models, Self-Compensating**

Dimensions on following page.

**Rear Flange**

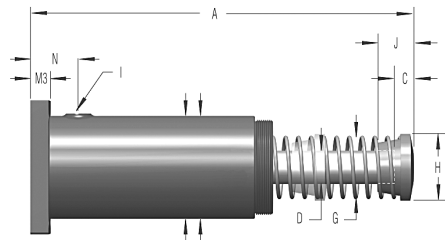

AA & SA adjustable models only  
 4.25 (108.0 mm) – 2" bore  
 5.50 (139.7 mm) – 3" bore

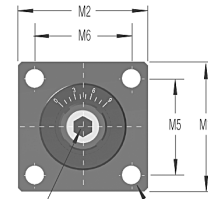

5/16" (8 mm)  
 hex socket adjuster  
 adjustable models only

**Front Flange**

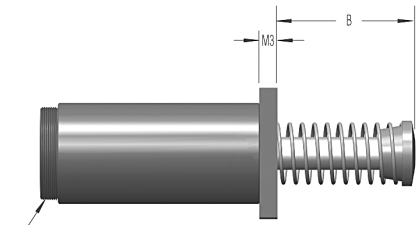

M100 x 2 – 2" bore  
 M130 x 2 – 3" bore

**2" Bore Foot Mount**

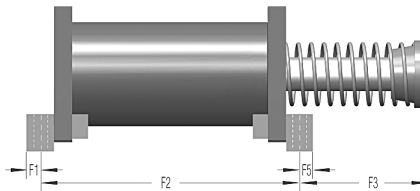
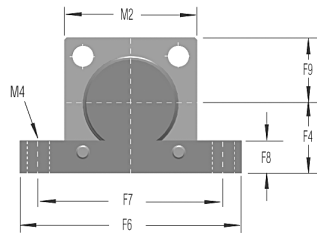

**Rectangular Flange**

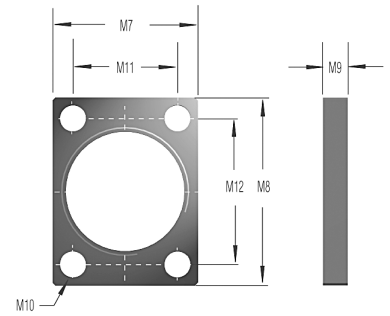

**3" Bore Foot Mount**

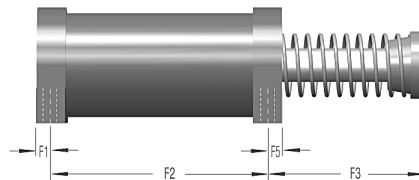
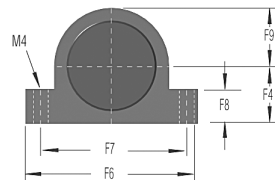

**Clevis Mount**

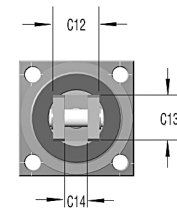
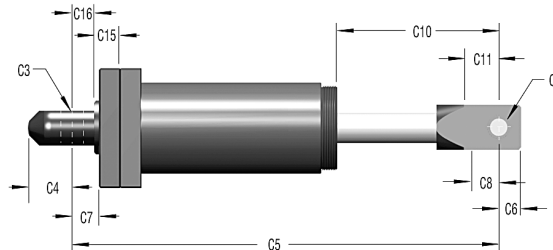
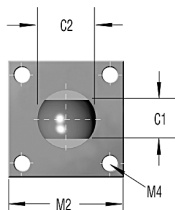



CA 2, CA 3 Bore Series – Heavy Duty Models, Self-Compensating

Size	Stroke	A	B	C	D	G	H	I	J	N	V	C1	C2	C3	C4	C5	C6	C7	C8	C10	C11
CA 2x2	2.00 (50.8)	12.31 (312.7)	4.31 (109.5)	0.82 (20.8)	1.38 (35.1)	3.06 (77.7)	2.75 (69.9)	3/4 NPT	1.38 (35.1)	3.50 (88.9)	4.25 (108.0)	1.50 (38.1)	2.25 (57.2)	1.005 (25.5)	1.00 (25.4)	17.00 (431.8)	1.00 (25.4)	2.00 (50.8)	1.50 (38.1)	6.05 (153.7)	2.06 (52.3)
CA 2x4	4.00 (101.6)	16.31 (414.0)	6.31 (160.3)	0.82 (20.8)	1.38 (35.1)	3.06 (77.7)	2.75 (69.9)	3/4 NPT	1.38 (35.1)	3.50 (88.9)	4.25 (108.0)	1.50 (38.1)	2.25 (57.2)	1.005 (25.5)	1.00 (25.4)	21.00 (533.4)	1.00 (25.4)	2.00 (50.8)	1.50 (38.1)	8.05 (204.4)	2.06 (52.3)
CA 2x6	6.00 (152.4)	20.31 (515.9)	8.31 (211.1)	0.82 (20.8)	1.38 (35.1)	3.63 (92.2)	2.75 (69.9)	3/4 NPT	1.38 (35.1)	3.50 (88.9)	4.25 (108.0)	1.50 (38.1)	2.25 (57.2)	1.005 (25.5)	1.00 (25.4)	25.00 (635.0)	1.00 (25.4)	2.00 (50.8)	1.50 (38.1)	10.05 (255.2)	2.06 (52.3)
CA 2x8	8.00 (203.2)	25.31 (642.9)	11.31 (287.3)	1.82 (46.2)	1.38 (35.1)	4.00 (101.6)	3.63 (92.2)	3/4 NPT	2.38 (60.5)	3.50 (88.9)	4.25 (108.0)	1.50 (38.1)	2.25 (57.2)	1.005 (25.5)	1.00 (25.4)	29.00 (736.6)	1.00 (25.4)	2.00 (50.8)	1.50 (38.1)	12.05 (306.1)	0.75 (19.0)
CA 2x10	10.00 (254)	29.31 (744.5)	13.31 (338.1)	1.82 (46.2)	1.38 (35.1)	4.50 (114.3)	4.25 (108.0)	3/4 NPT	2.38 (60.5)	3.50 (88.9)	4.25 (108.0)	1.50 (38.1)	2.25 (57.2)	1.005 (25.5)	1.00 (25.4)	33.00 (838.2)	1.00 (25.4)	2.00 (50.8)	1.50 (38.1)	14.05 (356.9)	1.06 (26.9)
CA 3x5	5.00 (127)	19.25 (489.0)	8.25 (209.6)	2.00 (50.8)	1.75 (44.5)	4.75 (120.7)	4.38 (111.3)	3/4 NPT	2.75 (69.9)	3.13 (79.5)	5.50 (139.7)	1.50 (38.1)	2.25 (57.2)	1.01 (25.5)	1.00 (25.4)	23.00 (584.2)	1.00 (25.4)	2.00 (50.8)	1.50 (38.1)	9.05 (229.9)	1.12 (28.4)
CA 3x8	8.00 (203.2)	25.25 (641.4)	11.25 (285.8)	2.00 (50.8)	1.75 (44.5)	4.75 (120.7)	4.38 (111.3)	3/4 NPT	2.75 (69.9)	3.13 (79.5)	5.50 (139.7)	1.50 (38.1)	2.25 (57.2)	1.01 (25.5)	1.00 (25.4)	29.00 (736.6)	1.00 (25.4)	2.00 (50.8)	1.50 (38.1)	12.05 (306.1)	1.12 (28.4)
CA 3x12	12.00 (304.8)	35.03 (889.8)	17.03 (432.6)	2.00 (50.8)	1.75 (44.5)	4.84 (122.9)	4.38 (111.3)	3/4 NPT	2.75 (69.9)	3.13 (79.5)	5.50 (139.7)	1.50 (38.1)	2.25 (57.2)	1.01 (25.5)	1.00 (25.4)	38.78 (985)	1.00 (25.4)	2.00 (50.8)	1.50 (38.1)	17.83 (452.9)	1.12 (28.4)
Size	Stroke	C12	C13	C14	C15	C16	F1	F2	F3	F4	F5	F6	F7	F8	F9	M1	M2	M3	M4	M5	M6
CA 2x2	2.00 (50.8)	3.5 (88.9)	2.00 (50.8)	1.50 (38.1)	1.25 (31.8)	1.75 (44.5)	0.63 (16.0)	9.5 (241.3)	3.44 (87.4)	3.13 (79.5)	0.63 (16.0)	8.00 (203.2)	6.50 (165.1)	1.50 (38.1)	2.75 (69.9)	5.50 (139.7)	5.50 (139.7)	0.75 (19.1)	0.66 (16.8)	4.38 (111.3)	4.38 (111.3)
CA 2x4	4.00 (101.6)	3.5 (88.9)	2.00 (50.8)	1.50 (38.1)	1.25 (31.8)	1.75 (44.5)	0.63 (16.0)	11.5 (292.1)	5.44 (138.2)	3.13 (79.5)	0.63 (16.0)	8.00 (203.2)	6.50 (165.1)	1.50 (38.1)	2.75 (69.9)	5.50 (139.7)	5.50 (139.7)	0.75 (19.1)	0.66 (16.8)	4.38 (111.3)	4.38 (111.3)
CA 2x6	6.00 (152.4)	3.5 (88.9)	2.00 (50.8)	1.50 (38.1)	1.25 (31.8)	1.75 (44.5)	0.63 (16.0)	13.5 (342.9)	7.44 (189.0)	3.13 (79.5)	0.63 (16.0)	8.00 (203.2)	6.50 (165.1)	1.50 (38.1)	2.75 (69.9)	5.50 (139.7)	5.50 (139.7)	0.75 (19.1)	0.66 (16.8)	4.38 (111.3)	4.38 (111.3)
CA 2x8	8.00 (203.2)	3.5 (88.9)	2.00 (50.8)	1.50 (38.1)	1.25 (31.8)	1.75 (44.5)	0.63 (16.0)	15.5 (393.7)	10.44 (265.2)	3.13 (79.5)	0.63 (16.0)	8.00 (203.2)	6.50 (165.1)	1.50 (38.1)	2.75 (69.9)	5.50 (139.7)	5.50 (139.7)	0.75 (19.1)	0.66 (16.8)	4.38 (111.3)	4.38 (111.3)
CA 2x10	10.00 (254.0)	3.5 (88.9)	2.00 (50.8)	1.50 (38.1)	1.25 (31.8)	1.75 (44.5)	0.63 (16.0)	17.5 (444.5)	12.44 (316.0)	3.13 (79.5)	0.63 (16.0)	8.00 (203.2)	6.50 (165.1)	1.50 (38.1)	2.75 (69.9)	5.50 (139.7)	5.50 (139.7)	0.75 (19.1)	0.66 (16.8)	4.38 (111.3)	4.38 (111.3)
CA 3x5	5.00 (127.0)	3.5 (88.9)	2.00 (50.8)	1.50 (38.1)	1.25 (31.8)	1.75 (44.5)	1.00 (25.4)	10.25 (260.4)	8.50 (215.9)	3.15 (80.0)	1.00 (25.4)	10.00 (254.0)	8.50 (215.9)	1.73 (43.9)	3.15 (80.0)	6.00 (152.4)	6.50 (165.1)	1.00 (25.4)	0.66 (16.8)	4.88 (124.0)	5.38 (136.7)
CA 3x8	8.00 (203.2)	3.5 (88.9)	2.00 (50.8)	1.50 (38.1)	1.25 (31.8)	1.75 (44.5)	1.00 (25.4)	13.25 (336.6)	11.50 (292.1)	3.15 (80.0)	1.00 (25.4)	10.00 (254.0)	8.50 (215.9)	1.73 (43.9)	3.15 (80.0)	6.00 (152.4)	6.50 (165.1)	1.00 (25.4)	0.66 (16.8)	4.88 (124.0)	5.38 (136.7)
CA 3x12	12.00 (304.8)	3.5 (88.9)	2.00 (50.8)	1.50 (38.1)	1.25 (31.8)	1.75 (44.5)	1.00 (25.4)	17.25 (438.2)	17.28 (438.9)	3.15 (80.0)	1.00 (25.4)	10.00 (254.0)	8.50 (215.9)	1.73 (43.9)	3.15 (80.0)	6.00 (152.4)	6.50 (165.1)	1.00 (25.4)	0.66 (16.8)	4.88 (124.0)	5.38 (136.7)
Size		M7	M8	M9	M10	M11	M12														
CA 3 A 3	Rectangular Flange	6.50 (165.1)	8.00 (203.2)	1.00 (25.4)	0.78 (19.8)	4.50 (114.3)	6.50 (165.1)														

Features

Heavy Industrial Shock Absorbers CA 4 - Self-Compensating

CA 4" Bore Series of self-compensating shock absorbers are designed for extremely heavy duty applications and provide smooth deceleration under changing conditions. High energy capacities combined with wide effective weight ranges qualify these units to perform in the most demanding environments.

Applications include:

Foundry, steel, marine, lumber and other heavy equipment industries.



Operating information

Impact velocity range: 1 to 16.5 ft/sec (0.30 to 5 m/sec)  
Operating temperature: 10°F to 150°F (-12°C to 66°C)

Ordering information – CA 4 series, self-compensating

<b>CA</b>	<b>4</b>	x	<b>8</b>	<b>R</b>	-	<b>5</b>
Return Method and Accumulator Style	Bore Size		Stroke Length	Mounting Style		Effective Weight
<b>CA</b> Spring Return, Internal Accumulator	4		6	<b>-F</b> Front Flange		<b>-3</b> Light
<b>CAA</b> Air Return, External Accumulator			8	<b>-R</b> Rear Flange		<b>-5</b> Medium
<b>CSA</b> Spring Return, External Accumulator			16	<b>-RP</b> Rear Standard		<b>-7</b> Heavy
<b>CNA</b> Self Return (Clevis), Internal Accumulator				<b>-FP</b> Front Standard		
				<b>-FRP</b> Front And Rear Standard		
				<b>-S</b> Side Foot Mount		
				<b>-C</b> Clevis Mount		

Stroke Inches 1 inch = 25.4 mm	E3 Max Energy Per Cycle, inch lbs 1 in lb = .11 Nm	We Effective Weight lbs, 1 lb = .45 kg	E4 Max Energy Per Hour, in lbs/Hour 1 in lb/Hour = .11 Nm/Hour			Model Number
			Self-Contained	A/O Tank	A/O Re-Circulating	
6.00	420,000	8,000-19,000	27,000,000	45,000,000	58,000,000	CA 4x6-3
6.00	420,000	19,000-41,000	27,000,000	45,000,000	58,000,000	CA 4x6-5
6.00	420,000	41,000-94,000	27,000,000	45,000,000	58,000,000	CA 4x6-7
8.00	560,000	11,000-25,000	30,000,000	50,000,000	65,000,000	CA 4x8-3
8.00	560,000	25,000-55,000	30,000,000	50,000,000	65,000,000	CA 4x8-5
8.00	560,000	55,000-125,000	30,000,000	50,000,000	65,000,000	CA 4x8-7
16.00	1,120,000	22,000-50,000	50,000,000	85,000,000	110,000,000	CA 4x16-3
16.00	1,120,000	50,000-110,000	50,000,000	85,000,000	110,000,000	CA 4x16-5
16.00	1,120,000	110,000-250,000	50,000,000	85,000,000	110,000,000	CA 4x16-7

Specifications

- Mechanical stop – 4" bore: must be provided .09 inch (2.3mm) before end of stroke
- Oil type – ATF
- Materials –
  - Steel body - with black oxide finish
  - Piston rod - high tensile steel, hardened & chrome plated
  - Rod end button - hardened steel with black oxide finish
  - Return spring - zinc plated

Model	Return Force lbs (N)	Return Time sec	Shipping Weight lbs (kg)
4 x 6	108-222 (480-1,000)	Consult Factory	132 (60)
4 x 8	71-222 (310-1,000)	Consult Factory	150 (68)
4 x 16	Consult Factory	Consult Factory	321 (146)



For inventory, lead times, and kit lookup, visit [www.pdnplu.com](http://www.pdnplu.com)

M39

Parker Hannifin Corporation  
Pneumatic Division  
Wadsworth, Ohio  
[www.parker.com/pneumatics](http://www.parker.com/pneumatics)

Industrial Shock Absorbers



**CA 4" Bore Series – Heavy Duty Models, Self-Compensating**

**Rear Flange**

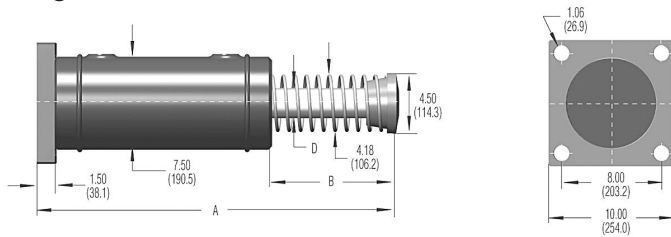

**Front Flange**

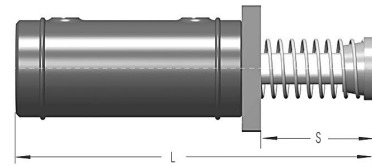

**Standard Mount**

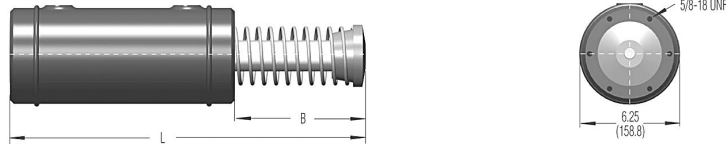

**Side-Foot Mount**

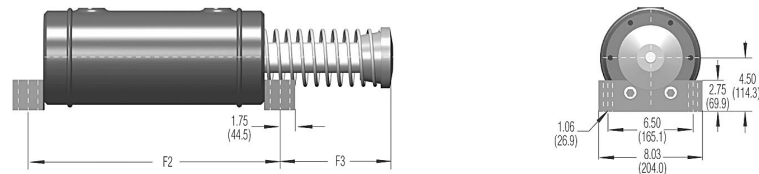

**Clevis Mount**

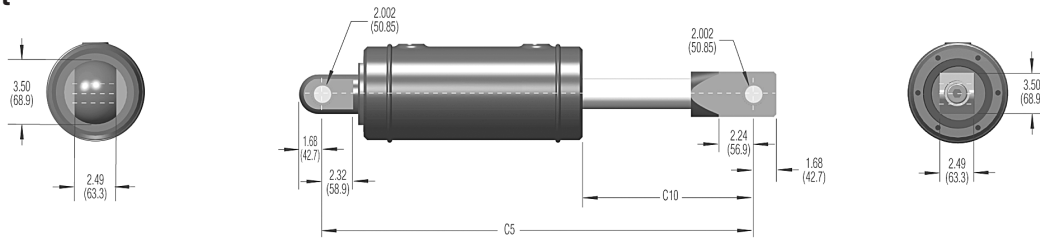

Size	Stroke	A	B	D	H	L	S	C5	C10	F2	F3
CA 4 x 6	6.00 (152.4)	28.21 (716.5)	10.96 (278.4)	2.12 (53.8)	4.50 (114.3)	26.71 (678.4)	9.46 (240.3)	33.03 (839.0)	12.90 (327.7)	17.50 (447.5)	10.90 (276.3)
CSA 4 x 6	6.00 (152.4)	28.21 (716.5)	10.96 (278.4)	2.12 (53.8)	4.50 (114.3)	26.71 (678.4)	9.46 (240.3)	33.03 (839.0)	12.90 (327.7)	17.50 (447.5)	10.90 (276.3)
CAA 4 x 6	6.00 (152.4)	26.21 (665.7)	8.96 (227.6)	2.12 (53.8)	4.50 (114.3)	24.71 (628.4)	7.46 (188.0)	31.03 (788.2)	10.90 (276.9)	17.50 (447.5)	8.09 (205.5)
CNA 4 x 6	6.00 (152.4)	N/A	N/A	2.12 (53.8)	4.50 (114.3)	N/A	N/A	31.03 (788.2)	10.90 (276.9)	N/A	N/A
CA 4 x 8	8.00 (203.2)	32.31 (818.1)	12.96 (329.2)	2.12 (53.8)	4.50 (114.3)	30.71 (780.0)	11.46 (291.1)	37.03 (940.6)	14.90 (378.5)	19.50 (495.3)	12.09 (307.1)
CSA 4 x 8	8.00 (203.2)	32.31 (818.1)	12.96 (329.2)	2.12 (53.8)	4.50 (114.3)	30.71 (780.0)	11.46 (291.1)	37.03 (940.6)	14.90 (378.5)	19.50 (495.3)	12.09 (307.1)
CAA 4 x 8	8.00 (203.2)	30.21 (767.3)	10.96 (278.4)	2.12 (53.8)	4.50 (114.3)	28.71 (729.2)	9.46 (240.3)	35.03 (889.8)	12.90 (327.7)	19.50 (495.3)	10.09 (256.3)
CNA 4 x 8	8.00 (203.2)	N/A	N/A	2.12 (53.8)	4.50 (114.3)	N/A	N/A	35.03 (889.8)	12.90 (327.7)	N/A	N/A
CA 4 x 16	16.00 (406.4)	51.21 (1,300.7)	23.96 (608.6)	2.50 (63.5)	5.00 (127.0)	49.71 (1,262.6)	22.46 (570.5)	56.03 (1,423.2)	25.90 (657.9)	27.50 (698.5)	23.09 (586.5)
CSA 4 x 16	16.00 (406.4)	51.21 (1,300.7)	23.96 (608.6)	2.50 (63.5)	5.00 (127.0)	49.71 (1,262.6)	22.46 (570.5)	56.03 (1,423.2)	25.90 (657.9)	27.50 (698.5)	23.09 (586.5)
CAA 4 x 16	16.00 (406.4)	46.21 (1,173.7)	18.96 (481.6)	2.50 (63.5)	5.00 (127.0)	44.71 (1,135.6)	17.46 (443.5)	51.03 (1,296.2)	20.90 (530.9)	27.50 (698.5)	18.09 (459.5)
CNA 4 x 16	16.00 (406.4)	N/A	N/A	2.50 (63.5)	5.00 (127.0)	N/A	N/A	51.03 (1,296.2)	20.90 (530.9)	N/A	N/A

## Heavy Industrial Shock Absorbers A 2 and A 3 - Adjustable

A2 and A3 Series adjustable shock absorbers are capable of decelerating heavy duty loads. These reliable units replace the former 2" and 3" large bore adjustable shock absorbers.

Energy capacity ratings are 228% of former models. In addition, effective weight ranges have increased dramatically, resulting in the capability of handling a wider range of applications and increases in velocity. The units are easily adjusted by means of a 5/16 inch (8 mm) hex socket adjuster located at the bottom of the outer body. These dependable shock absorbers are maintenance free and are available self-contained or for use with an external air/oil tank.

Features include a considerably reduced outer diameter, internal accumulator and threaded mounting brackets, easily adaptable to the front or rear of the outer body.

**Applications include:**

Foundry, steel, marine, lumber, and other heavy equipment industries.



**Operating information**

Impact velocity range:	0.33 to 16.5 ft/sec (0.1 to 5 m/sec)
Operating temperature:	10°F to 150°F (-12°C to 66°C)

**Ordering information – A 2 & A 3 series, adjustable**

<b>A</b>		<b>2</b>	<b>x</b>	<b>8</b>	-	<b>R</b>
<b>Return Method and Accumulator Style</b>		<b>Bore Size</b>	<b>Stroke Length</b>		<b>Mounting Style</b>	
<b>A</b>	Spring Return, Internal Accumulator	<b>2</b>	2		<b>-F</b> Front Flange	
<b>AA</b>	Air Return, External Accumulator	<b>3*</b>	4		<b>-R</b> Rear Flange	
<b>SA</b>	Spring Return, External Accumulator	5		<b>-RF</b> Front Rectangular Flange		
<b>NA</b>	Self Return (Clevis), Internal Accumulator	6		<b>-RR</b> Rear Rectangular Flange		
		* A no button option is available on the 3" Bore only as a special.		<b>-S</b> Side Foot Mount		
				<b>-C</b> Clevis Mount		

Stroke Inches 1 inch = 25.4 mm	E3 Max Energy Per Cycle, inch lbs 1 in lb = .11 Nm	We Effective Weight lbs, 1 lb = .45 kg	E4 Max Energy Per Hour, in lbs/Hour 1 in lb/Hour = .11 Nm/Hour			Model Number
			Self-Contained	A/O Tank	A/O Re-Circulating	
2.00	32,000	560-170,000	9,600,000	12,000,000	15,600,000	<b>A 2x2</b>
4.00	80,000	510-160,000	12,000,000	15,000,000	19,500,000	<b>A 2x4</b>
6.00	120,000	570-190,000	14,400,000	18,000,000	23,500,000	<b>A 2x6</b>
8.00	170,000	580-200,000	16,800,000	21,000,000	27,000,000	<b>A 2x8</b>
10.00	210,000	720-250,000	19,200,000	24,000,000	31,000,000	<b>A 2x10</b>
5.00	140,000	1,050-340,000	20,000,000	25,000,000	32,500,000	<b>A 3x5</b>
8.00	250,000	1,200-400,000	32,000,000	40,000,000	52,000,000	<b>A 3x8</b>
12.00	390,000	1,350-450,000	48,000,000	60,000,000	78,000,000	<b>A 3x12</b>

**Specifications**

- Mechanical stop – must be provided .09 inch (2.3 mm) before end of stroke.
- Oil type – ATF
- Materials –
  - Steel body - with black oxide finish
  - Piston rod - high tensile steel, hardened & chrome plated
  - Return spring - zinc plated
 To avoid reducing heat dissipation, do not paint.
- Adjustment - After installation of the shock absorber, cycle the machine a number of times. Turn the hex socket adjuster against the scale marked 0 to 9, until optimum deceleration is achieved (i.e. smooth deceleration throughout the stroke).
- Hard impact at the start of stroke-turn adjuster toward 9.
- Hard set-down at the end of stroke-turn adjuster toward 0.

Model	Return Force lbs (N)	Return Time sec	Shipping Weight lbs (kg)
<b>A 2 x 2</b>	48-63 (214-280)	0.25	31.5 (14.29)
<b>A 2 x 4</b>	34-63 (151-280)	0.50	36.9 (16.74)
<b>A 2 x 6</b>	34-90 (151-400)	0.60	42.6 (19.32)
<b>A 2 x 8</b>	51-144 (227-641)	0.70	49.1 (22.27)
<b>A 2 x 10</b>	35-101 (156-449)	0.80	57.8 (26.22)
<b>A 3 x 5</b>	59-156 (262-694)	0.60	72.1 (32.70)
<b>A 3 x 8</b>	62-162 (275-721)	0.80	84.9 (38.51)
<b>A 3 x 12</b>	60-160 (267-712)	1.20	105.0 (47.63)



For inventory, lead times, and kit lookup, visit [www.pdnplu.com](http://www.pdnplu.com)

M41

**Parker Hannifin Corporation**  
Pneumatic Division  
Wadsworth, Ohio  
[www.parker.com/pneumatics](http://www.parker.com/pneumatics)

Industrial Shock Absorbers

M

**A 2", A 3" Bore Series – Heavy Duty Models, Adjustable**

Dimensions on following page.

**Rear Flange**

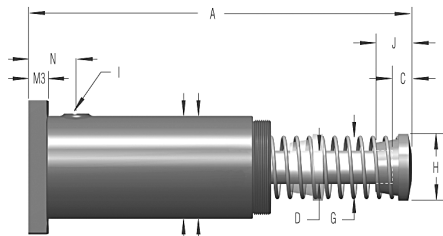

AA & SA adjustable models only  
 4.25 (108.0 mm) – 2" bore  
 5.50 (139.7 mm) – 3" bore

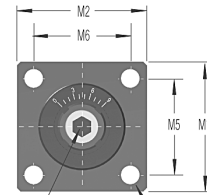

5/16" (8 mm)  
 hex socket adjuster  
 adjustable models only

**Front Flange**

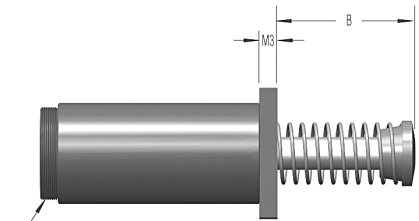

M100 x 2 – 2" bore  
 M130 x 2 – 3" bore

**2" Bore Foot Mount**

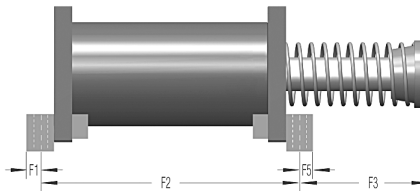
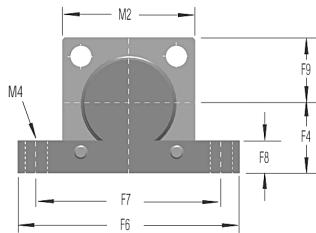

**Rectangular Flange**

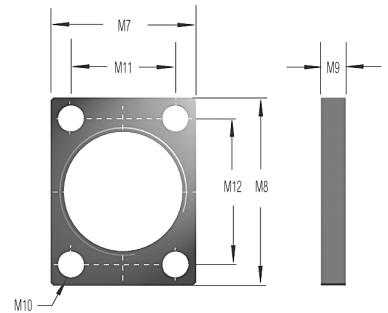

**3" Bore Foot Mount**

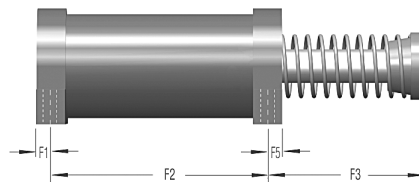
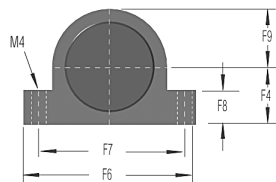

**2" & 3" Bore Models**

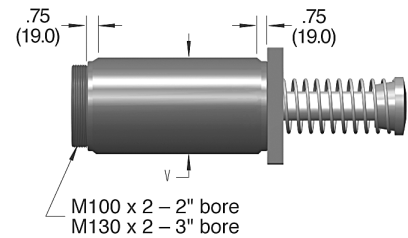

**Clevis Mount**

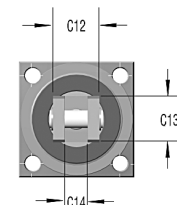
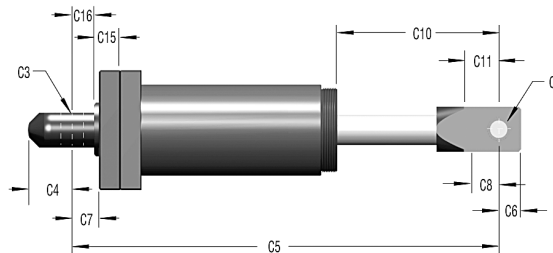
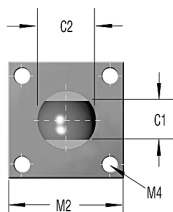

A 2", A 3" Bore Series – Heavy Duty Models, Adjustable

Size	Stroke	A	B	C	D	G	H	I	J	N	V*	C1	C2	C3	C4	C5	C6	C7	C8	C10	C11
A 2x2	2.00 (50.8)	12.31 (312.7)	4.31 (109.5)	0.82 (20.8)	1.38 (35.1)	3.06 (77.7)	2.75 (69.9)	3/4 NPT	1.38 (35.1)	3.50 (88.9)	4.63 (118.0)	1.50 (38.1)	2.25 (57.2)	1.005 (25.5)	1.00 (25.4)	17.00 (431.8)	1.00 (25.4)	2.00 (50.8)	1.50 (38.1)	6.05 (153.7)	2.06 (52.3)
A 2x4	4.00 (101.6)	16.31 (414.0)	6.31 (160.3)	0.82 (20.8)	1.38 (35.1)	3.06 (77.7)	2.75 (69.9)	3/4 NPT	1.38 (35.1)	3.50 (88.9)	4.63 (118.0)	1.50 (38.1)	2.25 (57.2)	1.005 (25.5)	1.00 (25.4)	21.00 (533.4)	1.00 (25.4)	2.00 (50.8)	1.50 (38.1)	8.05 (204.4)	2.06 (52.3)
A 2x6	6.00 (152.4)	20.31 (515.9)	8.31 (211.1)	0.82 (20.8)	1.38 (35.1)	3.63 (92.2)	2.75 (69.9)	3/4 NPT	1.38 (35.1)	3.50 (88.9)	4.63 (118.0)	1.50 (38.1)	2.25 (57.2)	1.005 (25.5)	1.00 (25.4)	25.00 (635.0)	1.00 (25.4)	2.00 (50.8)	1.50 (38.1)	10.05 (255.2)	2.06 (52.3)
A 2x8	8.00 (203.2)	25.31 (642.9)	11.31 (287.3)	1.82 (46.2)	1.38 (35.1)	4.00 (101.6)	3.63 (92.2)	3/4 NPT	2.38 (60.5)	3.50 (88.9)	4.63 (118.0)	1.50 (38.1)	2.25 (57.2)	1.005 (25.5)	1.00 (25.4)	29.00 (736.6)	1.00 (25.4)	2.00 (50.8)	1.50 (38.1)	12.05 (306.1)	0.75 (19.0)
A 2x10	10.00 (254)	29.31 (744.5)	13.31 (338.1)	1.82 (46.2)	1.38 (35.1)	4.50 (114.3)	4.25 (108.0)	3/4 NPT	2.38 (60.5)	3.50 (88.9)	4.63 (118.0)	1.50 (38.1)	2.25 (57.2)	1.005 (25.5)	1.00 (25.4)	33.00 (838.2)	1.00 (25.4)	2.00 (50.8)	1.50 (38.1)	14.05 (356.9)	1.06 (26.9)
A 3x5	5.00 (127)	19.25 (489.0)	8.25 (209.6)	2.00 (50.8)	1.75 (44.5)	4.75 (120.7)	4.38 (111.3)	3/4 NPT	2.75 (69.9)	3.13 (79.5)	6.00 (152.4)	1.50 (38.1)	2.25 (57.2)	1.01 (25.5)	1.00 (25.4)	23.00 (584.2)	1.00 (25.4)	2.00 (50.8)	1.50 (38.1)	9.05 (229.9)	1.12 (28.4)
A 3x8	8.00 (203.2)	25.25 (641.4)	11.25 (285.8)	2.00 (50.8)	1.75 (44.5)	4.75 (120.7)	4.38 (111.3)	3/4 NPT	2.75 (69.9)	3.13 (79.5)	6.00 (152.4)	1.50 (38.1)	2.25 (57.2)	1.01 (25.5)	1.00 (25.4)	29.00 (736.6)	1.00 (25.4)	2.00 (50.8)	1.50 (38.1)	12.05 (306.1)	1.12 (28.4)
A 3x12	12.00 (304.8)	35.03 (889.8)	17.03 (432.6)	2.00 (50.8)	1.75 (44.5)	4.84 (122.9)	4.38 (111.3)	3/4 NPT	2.75 (69.9)	3.13 (79.5)	6.00 (152.4)	1.50 (38.1)	2.25 (57.2)	1.01 (25.5)	1.00 (25.4)	38.78 (985)	1.00 (25.4)	2.00 (50.8)	1.50 (38.1)	17.83 (452.9)	1.12 (28.4)
Size	Stroke	C12	C13	C14	C15	C16	F1	F2	F3	F4	F5	F6	F7	F8	F9	M1	M2	M3	M4	M5	M6
A 2x2	2.00 (50.8)	3.5 (88.9)	2.00 (50.8)	1.50 (38.1)	1.25 (31.8)	1.75 (44.5)	0.63 (16.0)	9.5 (241.3)	3.44 (87.4)	3.13 (79.5)	0.63 (16.0)	8.00 (203.2)	6.50 (165.1)	1.50 (38.1)	2.75 (69.9)	5.50 (139.7)	5.50 (139.7)	0.75 (19.1)	0.66 (16.8)	4.38 (111.3)	4.38 (111.3)
A 2x4	4.00 (101.6)	3.5 (88.9)	2.00 (50.8)	1.50 (38.1)	1.25 (31.8)	1.75 (44.5)	0.63 (16.0)	11.5 (292.1)	5.44 (138.2)	3.13 (79.5)	0.63 (16.0)	8.00 (203.2)	6.50 (165.1)	1.50 (38.1)	2.75 (69.9)	5.50 (139.7)	5.50 (139.7)	0.75 (19.1)	0.66 (16.8)	4.38 (111.3)	4.38 (111.3)
A 2x6	6.00 (152.4)	3.5 (88.9)	2.00 (50.8)	1.50 (38.1)	1.25 (31.8)	1.75 (44.5)	0.63 (16.0)	13.5 (342.9)	7.44 (189.0)	3.13 (79.5)	0.63 (16.0)	8.00 (203.2)	6.50 (165.1)	1.50 (38.1)	2.75 (69.9)	5.50 (139.7)	5.50 (139.7)	0.75 (19.1)	0.66 (16.8)	4.38 (111.3)	4.38 (111.3)
A 2x8	8.00 (203.2)	3.5 (88.9)	2.00 (50.8)	1.50 (38.1)	1.25 (31.8)	1.75 (44.5)	0.63 (16.0)	15.5 (393.7)	10.44 (265.2)	3.13 (79.5)	0.63 (16.0)	8.00 (203.2)	6.50 (165.1)	1.50 (38.1)	2.75 (69.9)	5.50 (139.7)	5.50 (139.7)	0.75 (19.1)	0.66 (16.8)	4.38 (111.3)	4.38 (111.3)
A 2x10	10.00 (254.0)	3.5 (88.9)	2.00 (50.8)	1.50 (38.1)	1.25 (31.8)	1.75 (44.5)	0.63 (16.0)	17.5 (444.5)	12.44 (316.0)	3.13 (79.5)	0.63 (16.0)	8.00 (203.2)	6.50 (165.1)	1.50 (38.1)	2.75 (69.9)	5.50 (139.7)	5.50 (139.7)	0.75 (19.1)	0.66 (16.8)	4.38 (111.3)	4.38 (111.3)
A 3x5	5.00 (127.0)	3.5 (88.9)	2.00 (50.8)	1.50 (38.1)	1.25 (31.8)	1.75 (44.5)	1.00 (25.4)	10.25 (260.4)	8.50 (215.9)	3.15 (80.0)	1.00 (25.4)	10.00 (254.0)	8.50 (215.9)	1.73 (43.9)	3.15 (80.0)	6.00 (152.4)	6.50 (165.1)	1.00 (25.4)	0.66 (16.8)	4.88 (124.0)	5.38 (136.7)
A 3x8	8.00 (203.2)	3.5 (88.9)	2.00 (50.8)	1.50 (38.1)	1.25 (31.8)	1.75 (44.5)	1.00 (25.4)	13.25 (336.6)	11.50 (292.1)	3.15 (80.0)	1.00 (25.4)	10.00 (254.0)	8.50 (215.9)	1.73 (43.9)	3.15 (80.0)	6.00 (152.4)	6.50 (165.1)	1.00 (25.4)	0.66 (16.8)	4.88 (124.0)	5.38 (136.7)
A 3x12	12.00 (304.8)	3.5 (88.9)	2.00 (50.8)	1.50 (38.1)	1.25 (31.8)	1.75 (44.5)	1.00 (25.4)	17.25 (438.2)	17.28 (438.9)	3.15 (80.0)	1.00 (25.4)	10.00 (254.0)	8.50 (215.9)	1.73 (43.9)	3.15 (80.0)	6.00 (152.4)	6.50 (165.1)	1.00 (25.4)	0.66 (16.8)	4.88 (124.0)	5.38 (136.7)
Size		M7	M8	M9	M10	M11	M12														
A 3	Rectangular Flange	6.50 (165.1)	8.00 (203.2)	1.00 (25.4)	0.78 (19.8)	4.50 (114.3)	6.50 (165.1)														

\* See rear flange illustration on page L40 for AA and SA model dimensions.



For inventory, lead times, and kit lookup, visit [www.pdnplu.com](http://www.pdnplu.com)

M43

Parker Hannifin Corporation  
Pneumatic Division  
Wadsworth, Ohio  
[www.parker.com/pneumatics](http://www.parker.com/pneumatics)



**Mounting Blocks**

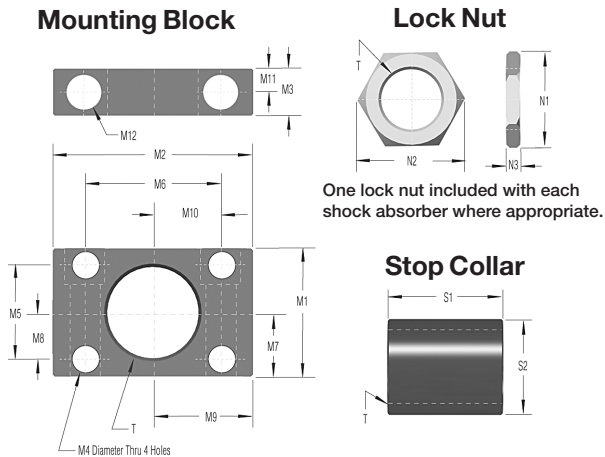

One lock nut included with each shock absorber where appropriate.



Side load adapters are available for select models, see pages N48 and N49.

Inches (mm)

Mounting Block		Lock Nut												Stop Collar							
Used With	Part #	T	M1	M2	M3	M4	M5	M6	M7	M8	M9	M10	M11	M12	Part #	N1	N2	N3	Part #	S1	S2
MC 10E	N/A	M8x0.75	-	-	-	-	-	-	-	-	-	-	-	-	250-0362	.43	.49	.12	N/A	-	-
MC 10M		M8x1													250-0482	(11)	(12.5)	(3.0)			
MC 25	250-0306	3/8-32 UNF	1.00 (25.4)	1.50 (38.1)	.56 (14.2)	See DIM M12	0 (0)	1.00 (25.4)	.50 (12.7)	0 (0)	.75 (19.1)	.50 (12.7)	.28 (7.1)	.18 Dia. Thru .31 C Bore x .20 Deep #6-32 Soc. Hd. Screw	250-0404	.50 (12.7)	.56 (14.2)	.09 (2.3)	250-0406	.81 (20.6)	.56 (14.2)
MC 25M	250-0307	M10x1	1.00 (25.4)	1.50 (38.1)	.56 (14.2)	See DIM M12	0 (0)	1.00 (25.4)	.50 (12.7)	0 (0)	.75 (19.1)	.50 (12.7)	.28 (7.1)	.45 Dia. Thru (8) C Bore x (5) Deep M4x7 Soc. Hd. Screw	250-0315	.55 (14.0)	.59 (15.0)	.12 (3.0)	250-0408	.79 (20.0)	.56 (14.3)
MA 35	250-0308	1/2-20 UNF	1.00 (25.4)	1.50 (38.1)	.56 (14.2)	See DIM M12	0 (0)	1.00 (25.4)	.50 (12.7)	0 (0)	.75 (19.1)	.50 (12.7)	.28 (7.1)	.18 Dia. Thru .31 C Bore x .20 Deep #6-32 Soc. Hd. Screw	250-0405	.62 (16.5)	.70 (17.8)	.13 (3.3)	250-0407	.81 (20.6)	.62 (15.7)
MC 75																					
MA 35M	250-0309	M12x1	1.00 (25.4)	1.50 (38.1)	.56 (14.2)	See DIM M12	0 (0)	1.00 (25.4)	.50 (12.7)	0 (0)	.75 (19.1)	.50 (12.7)	.28 (7.1)	.45 Dia. Thru (8) C Bore x (5) Deep M4x7 Soc. Hd. Screw	250-0317	.55 (14.0)	.63 (16.0)	.16 (4.0)	250-0409	.79 (20.0)	.63 (16.0)
MC 75M																					
MA 150	250-0318	9/16-18 UNF	1.37 (34.8)	1.81 (46.0)	.62 (15.7)	.22 (5.6)	1.00 (25.4)	1.38 (35.1)	.69 (17.5)	.50 (12.7)	.91 (23.1)	.69 (17.5)	.31 (7.9)	.21 Dia. Thru .32 C Bore x .32 Deep #10-32 Soc. Hd. Screw	250-0231	.88 (22.4)	1.00 (25.4)	.31 (7.9)	250-0271	.75 (19.1)	.69 (17.5)
MC 150																					
SC 190																					
MA 150M	250-0352	M14x1.5	1.10 (28.0)	1.77 (45.0)	.63 (16.0)	.18 (4.5)	0 (0)	1.38 (35.0)	.55 (14.0)	0 (0)	.89 (22.5)	.69 (17.5)	.31 (7.9)	.45 Dia. Thru (8) C Bore x (5) Deep M4x7 Soc. Hd. Screw	250-0233	.67 (17.0)	.77 (19.6)	.20 (5.0)	250-0272	.79 (20.0)	.69 (17.5)
MC 225																					
MA 225	250-0401	3/4-16 UNF	1.50 (38.1)	2.00 (50.8)	.62 (15.7)	.22 (5.6)	1.12 (28.4)	1.50 (38.1)	.75 (19.1)	.56 (14.2)	1.00 (25.4)	.75 (19.1)	.31 (7.9)	.22 Dia. Thru .33 C Bore x .45 Deep #10-32 Soc. Hd. Screw	250-0399	1.00 (25.4)	1.15 (29.2)	.25 (6.4)	250-0403	1.25 (31.8)	1.00 (25.4)
MVC 225																					
SC 300																					
MC 225M																					
MA 225M	250-0353	M20x1.5	1.38 (35.0)	1.85 (47.0)	.63 (16.0)	.22 (5.6)	1.00 (25.4)	1.38 (35.0)	.69 (17.5)	.50 (12.7)	.93 (23.5)	.69 (17.5)	.31 (7.9)	.5 Dia. Thru (10) C Bore x (10) Deep M5x8 Soc. Hd. Screw	250-0207	.94 (24.0)	1.10 (28.0)	.24 (6.0)	250-0410	.98 (25.0)	.98 (25.0)
MVC 225M																					
SC 300M																					
MC 600																					
MA 600	250-0402	1-12 UNF	1.50 (38.1)	2.00 (50.8)	.62 (15.7)	.22 (5.6)	1.12 (28.4)	1.50 (38.1)	.75 (19.1)	.56 (14.2)	1.00 (25.4)	.75 (19.1)	.31 (7.9)	.22 Dia. Thru .33 C Bore x .45 Deep #10-32 Soc. Hd. Screw	250-0400	1.25 (31.8)	1.44 (36.6)	.25 (6.4)	250-0275	1.75 (44.5)	1.25 (31.8)
MVC 600																					
SC 650																					
MA 900																					
MVC 900																					
SC 925																					
MC600ML	N/A	-	-	-	-	-	-	-	-	-	-	-	-	-	250-0239	1.25 (31.8)	1.44 (36.6)	.31 (7.9)	250-0263	1.77 (45.0)	1.26 (32.0)
MC 600M																					
MA 600M																					
MVC 600M	250-0044	M25x1.5	1.38 (35.0)	1.85 (47.0)	.63 (16.0)	.22 (5.6)	1.00 (25.4)	1.38 (35.0)	.69 (17.5)	.50 (12.7)	.93 (23.5)	.69 (17.5)	.31 (7.9)	.5 Dia. Thru (10) C Bore x (10) Deep M5x8 Soc. Hd. Screw	250-0040	1.18 (30.0)	1.36 (34.6)	.31 (7.9)	250-0276	1.26 (32.0)	1.18 (30.0)
SC 650M																					
MA 900M																					
MVC 900M																					
SC 925M																					

**Air Bleed Collar**

Used with	Model	Part Number
MC 150 M	SP-14	10781-000
MC 225 M	SP-20	10782-000
MC 600 M	SP-25	10783-000

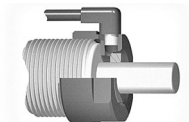

**Clamp**

Used with	Model	Part Number
MC 600 M	MB-25	10780-000

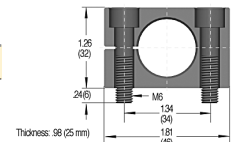



**StopLight™**

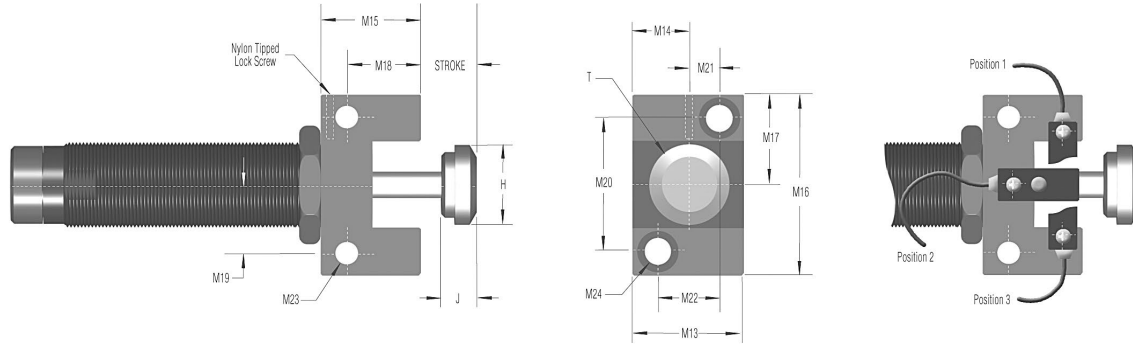

StopLight™ Switches are available in both NPN and PNP styles. Part numbers are 250-3 NPN and 250-3 PNP, respectively. The switches can be used with any StopLight mounting blocks.

\* A complete StopLight assembly includes mounting block, proximity switch and steel button. Use the table below to order MC Series buttons. Steel buttons are an integral part of series MA and SC2 and MVC units. Shock absorbers are ordered separately.

Used With	Part #	T	H	J	M13	M14	M15	M16	M17	M18	M19	M20	M21	M22	M23	M24	
MA 150 MC 150* SC 190	250-0377	9/16-18 UNF	.47 (11.9)	.43 (10.9)	.75 (19.0)	.38 (22.3)	.88 (22.3)	1.25 (31.8)	.63 (15.9)	.57 (14.5)	.44 (11.1)	.88 (22.2)	.19 (4.7)	.38 (9.5)	.180 (4.6)	.315 (8.0)	
MC 150M* SC 190M		M14x 1.5	.47 (11.9)	.43 (10.9)	.75 (19.0)	.38 (22.3)	.88 (22.3)	1.25 (31.8)	.63 (15.9)	.57 (14.5)	.44 (11.1)	.88 (22.2)	.19 (4.7)	.38 (9.5)	.180 (4.6)	.315 (8.0)	
MC 225* MA 225 MVC 225 SC 300		250-0379	3/4-16 UNF	.66 (16.8)	.43 (10.9)	.94 (23.8)	.47 (11.9)	.94 (23.8)	1.56 (39.6)	.78 (19.8)	.63 (16.0)	.55 (14.0)	1.10 (28.0)	.24 (6.0)	.47 (12.0)	.216 (5.5)	.394 (10.0)
MC 225M MA 225M MVC 225M SC 300M	M20x 1.5		.66 (16.8)	.43 (10.9)	.94 (23.8)	.47 (11.9)	.94 (23.8)	1.56 (39.6)	.78 (19.8)	.63 (16.0)	.55 (14.0)	1.10 (28.0)	.24 (6.0)	.47 (12.0)	.216 (5.5)	.394 (10.0)	
MC 600* MA 600 MVC 600 MA 900 MVC 900 SC 650 SC 925			250-0381	1-12 UNF	.90 (22.9)	.43 (10.9)	1.18 (30.0)	.59 (15.0)	1.00 (25.4)	1.75 (44.5)	.88 (22.3)	.63 (16.0)	.63 (16.0)	1.26 (32.0)	.31 (8.0)	.63 (16.0)	.216 (5.5)
MC 600M* MA 600M MVC 600M MA 900M MVC 900M SC 650M SC 925M		M25x 1.5		.90 (22.9)	.43 (10.9)	1.18 (30.0)	.59 (15.0)	1.00 (25.4)	1.75 (44.5)	.88 (22.3)	.63 (16.0)	.63 (16.0)	1.26 (32.0)	.31 (8.0)	.63 (16.0)	.216 (5.5)	.394 (10.0)

Model	Steel button part number
MA 150	250-0383
MC 150, MC 150M	250-0111
MC 225, MC 225M	250-0112
MC 600, MC 600M	250-0113

Inches (mm)

**Specifications**

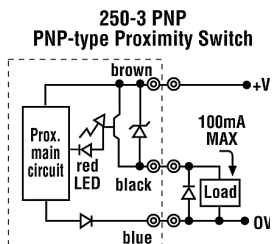
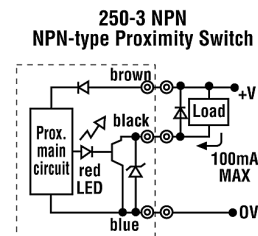

- Supply voltage – 10 to 27 VDC Ripple p to p 10% max
- Current consumption – 15 mA max (at 24 VDC)
- Control output – 3-Wire Output: 100 mA max  
Voltage Impression: 30 VDC max  
Residual Voltage: 1 VDC max
- Operator indicator – Red LED; Power off = dark; Stand By = Dim Light
- Detection – Bright Light
- Operating Temperature – 14°F to 140°F, -10°C to 60°C (At holding: 86°F to 176°F; 30°C to 80°C)
- Humidity – 45 to 85% RH (At holding: 35 to 95% RH)
- Variation due to ±20% max of detecting distance at 68°F (20°C)
- Temperature Fluctuation – with a temperature range of 14°F to 140° F (-10°C to 60°C)
- Variation due to ±5% max of detecting distance at 12/24 VDC
- Voltage fluctuation – when operated within 10 to 27 VDC
- Residual voltage 1V max (Load current at 100 mA)
- Insulation resistance – 10M Ω min (at 500 VDC)
- Dielectric resistance – 1,000 VAC 50/60Hz for 1 minute
- Degree of protection – IP67 (IEC144)



For inventory, lead times, and kit lookup, visit [www.pdnplu.com](http://www.pdnplu.com)

M45

**Parker Hannifin Corporation**  
 Pneumatic Division  
 Wadsworth, Ohio  
[www.parker.com/pneumatics](http://www.parker.com/pneumatics)

Industrial Shock Absorbers

**M**

**Miniature Shock Absorber Side Load Adapters**

**For Side Load in Excess of 3°**

With side load impact angles of more than 3° the operating lifetime of the shock absorber reduces rapidly due to increased wear of the rod bearings. The optional side load adapter provides a long lasting solution.

Material: Threaded body and plunger, hardened high tensile steel

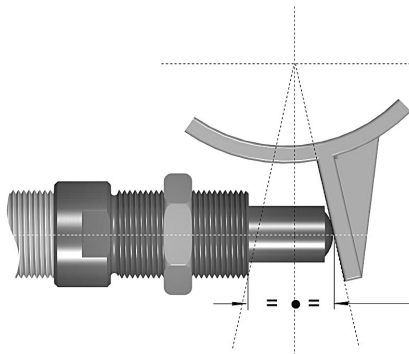
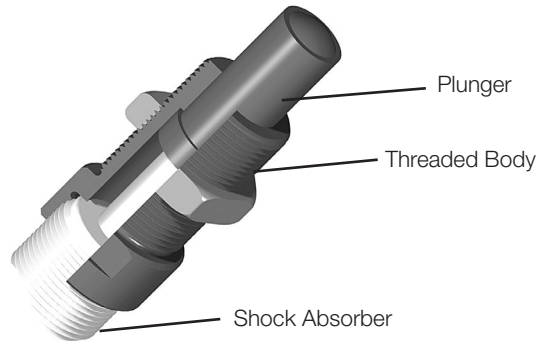
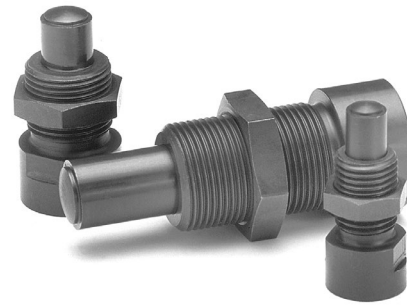

**Problem:** Rotary motion of the striking surface creates side load, which develops a bending moment on the piston rod. This can bend the rod in some cases. In all cases, side load will reduce seal and bearing life.

**Solution:** Use side load adapter.

**Formula:**  $\alpha = \tan^{-1} \left( \frac{s}{2 \cdot R_s} \right)$        $R_{smin} = \frac{s}{2 \cdot \tan \alpha_{max}}$

**Example:**  $s = .98$  (25mm)       $\alpha_{max} = 25^\circ$  (adapter 250-0560)

$R_s = 3.94$  (100mm)       $R_{smin} = \frac{.98}{2 \cdot \tan 25}$

$\alpha = \tan^{-1} \left( \frac{.98}{2 \cdot 3.94} \right)$        $R_{smin} = 1.05$  (27mm)

$\alpha = (7.09)^\circ$

$\alpha$  = angle of impact

$\alpha_{max}$  = maximum angle of impact

$s$  = stroke

$R_s$  = radius

$R_{smin}$  = minimum r

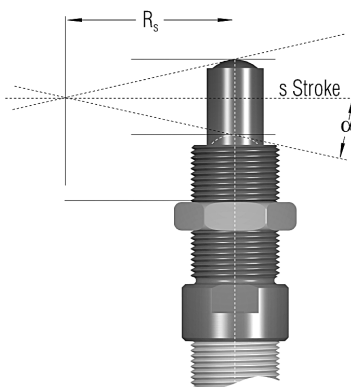

Miniature Shock Absorber Side Load Adapters

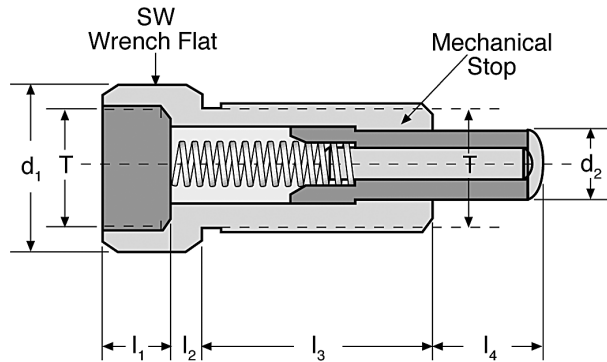

MC, MVC Series Model	SC Series Model	MA Series Model	Side Load Adapter	T	d1	d2	l1	l2	l3	l4	SW	Maximum Side Load (α)
MC 150M	N/A	MA 150M	250-0558	M14 x 1.5	0.70 (18)	0.35 (9)	0.31 (8)	0.15 (4)	0.78 (20)	0.49 (12.5)	0.62 (16)	25°
MC 225M	N/A	N/A	250-0559	M20 x 1.5	0.94 (24)	0.47 (12)	0.39 (10)	0.15 (4)	0.78 (20)	0.49 (12.5)	0.86 (22)	25°
MC 600M	N/A	N/A	250-0560	M25 x 1.5	1.18 (30)	0.62 (16)	0.39 (10)	0.23 (6)	1.50 (38)	0.98 (25)	1.06 (27)	25°
N/A	SC 190M-880*	N/A	250-0080	M14 x 1.5	0.70 (18)	0.35 (9)	0.39 (10)	0.15 (4)	1.02 (26)	0.62 (16)	0.62 (16)	25°
MVC 225M-880*	SC 300M-880*	MA 225M-880*	250-0081	M20 x 1.5	0.94 (24)	0.47 (12)	0.39 (10)	0.15 (4)	1.25 (32)	0.75 (19)	0.86 (22)	25°
MVC 600M-880*	SC 650M-880*	MA 600M-880*	250-0082	M25 x 1.5	1.18 (30)	0.62 (16)	0.39 (10)	0.23 (6)	1.50 (38)	0.98 (25)	1.06 (27)	25°

Inches (mm)

Notes:

1. Side load not to exceed 5". Maximum side load depends on application, shock absorber model, and stroke length.
2. The side load adapter can only be installed on select metric shock absorbers without rod end button.

Square and Rectangular Flanges

Used with	Square Flange	Rectangular Flange	T	M1	M2	M3	M4	M5	M6
MA 33 ML 33 MC 33		250-0016	1-1/4-12 UNF	1.50 (38.1)	2.00 (50.8)	0.38 (9.5)	.219 (5.6)	1.12 (28.4)	1.62 (41.2)
MA 33M ML 33M MC 33M	N/A	250-0293	M33x1.5	1.62 (41.1)	2.12 (53.8)	0.38 (9.5)	.278 (7.1)	1.10 (28.0)	1.65 (42.0)
MA 36 ML 36 MC 36		250-0633	1-3/8-12 UNF	1.75 (44.4)	2.00 (50.8)	0.38 (9.5)	.219 (5.6)	1.12 (28.4)	1.62 (41.2)
MA 36M ML 36M MC 36M	N/A	N/A	N/A	N/A	N/A	N/A	N/A	N/A	N/A
MA 45 ML 45 MC 45	250-0023	250-0024	1-3/4-12 UN	2.25 (57.2)	3.00 (76.2)	0.50 (12.7)	0.34 (8.7)	1.62 (41.2)	2.38 (60.5)
MA 45M ML 45M MC 45M	250-0298	250-0299	M45x1.5	2.25 (57.2)	3.00 (76.2)	0.50 (12.7)	0.35 (8.8)	1.62 (41.2)	2.38 (60.5)
MA 64 ML 64 MC 64	250-0028	N/A	2-1/2-12 UN	3.50 (88.9)	N/A	0.62 (15.9)	0.41 (10.4)	2.75 (69.6)	N/A
MA 64M ML 64M MC 64M	250-0302	N/A	M64x2	3.50 (88.9)	N/A	0.62 (15.9)	0.41 (10.4)	2.75 (69.6)	N/A

Inches (mm)

Square Flange

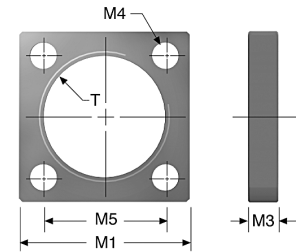

Rectangular Flange

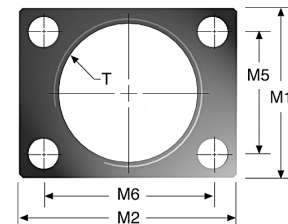

Stop Bars

Used with	Part #	S10	S11	S12	S13	S14	S15	S16
MA 33 ML 33 MC 33	250-0426	1.28 (32.5)	1.50 (38.1)	0.38 (9.7)	0.19 (4.8)	1.12 (28.4)	10-32 UNF	N/A
MA 33M ML 33M MC 33M	250-0427	1.28 (32.5)	1.50 (38.1)	0.38 (9.7)	0.19 (4.8)	1.12 (28.4)	M5x0.8	N/A
MA 36 ML 36 MC 36	250-0426	1.28 (32.5)	1.50 (38.1)	0.38 (9.7)	0.19 (4.8)	1.12 (28.4)	10-32 UNF	N/A
MA 36M ML 36M MC 36M	N/A	N/A	N/A	N/A	N/A	N/A	N/A	N/A
MA 45 ML 45 MC 45	250-0428	1.03 (26.2)	2.25 (57.2)	0.63 (16.0)	0.31 (7.9)	1.62 (41.3)	5/16-24 UNF	N/A
MA 45M ML 45M MC 45M	250-0639	1.03 (26.2)	2.25 (57.2)	0.63 (16.0)	0.31 (7.9)	1.62 (41.3)	M8x1.25	N/A
MA 6450 MA 64100 ML 6425 ML 6450 MC 6450 MC 64100	250-0430	1.44 (36.5)	3.50 (88.9)	0.50 (12.7)	0.25 (6.4)	2.75 (69.8)	3/8-24 UNF	1.37 (34.8)
MA 6450M MA 64100M ML 6425M ML 6450M MC 6450M MC 64100M	250-0640	1.44 (36.5)	3.50 (88.9)	0.50 (12.7)	0.25 (6.4)	2.75 (69.8)	M10x1.5	1.37 (34.8)
MA 64150 MC 64150	250-0432	2.31 (57.7)	3.50 (88.9)	0.50 (12.7)	0.25 (6.4)	2.75 (69.8)	3/8-24 UNF	1.37 (34.8)
MA 64150M MC 64150M	250-0641	2.31 (57.7)	3.50 (88.9)	0.50 (12.7)	0.25 (6.4)	2.75 (69.8)	M10x1.5	1.37 (34.8)
MAA 64150 MCA 64150	250-0435	2.18 (55.4)	3.50 (88.9)	0.50 (12.7)	0.25 (6.4)	2.75 (69.8)	3/8-24 UNF	1.37 (34.8)
MAA 64150M MCA 64150M	250-0649	2.18 (55.4)	3.50 (88.9)	0.50 (12.7)	0.25 (6.4)	2.75 (69.8)	M10x1.5	1.37 (34.8)

Inches (mm)

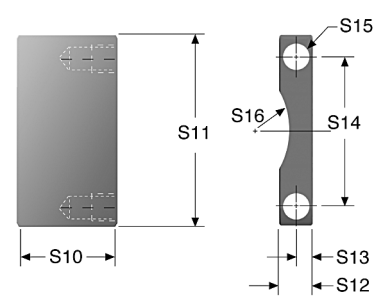
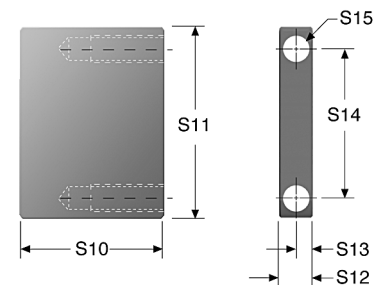

Hard metric stop bars available upon request.

Stop bars come in pairs, two bars per package.

**Flanged Stop Collars**

Used with	Part #	T	S1	S2	S3	S4	S5	S6	S7	
MA 33 ML 33 MC 33	250-0070	1-1/4-12	2.00	1.50	2.50	2.00	0.88	0.25	0.282	
		UNF	(50.8)	(38.1)	(63.5)	(50.8)	(22.4)	(6.4)	(7.16)	
MA 33M ML 33M MC 33M	250-0071	M33x1.5	2.00	1.50	2.50	2.00	0.88	0.25	0.282	
			(50.8)	(38.1)	(63.5)	(50.8)	(22.4)	(6.4)	(7.16)	
MA 36 ML 36 MC 36 MA 36M ML 36M MC 36M	N/A	N/A	N/A	N/A	N/A	N/A	N/A	N/A	N/A	
MA 45 ML 45 MC 45	250-0072	1-3/4-12	1.85	2.25	3.25	2.75	0.88	0.25	0.282	
			UN	(47.0)	(57.2)	(82.6)	(69.6)	(22.4)	(6.4)	(7.16)
MA 45M ML 45M MC 45M	250-0073	M45x1.5	1.85	2.25	3.25	2.75	0.88	0.25	0.282	
			(47.0)	(57.2)	(82.6)	(69.9)	(22.4)	(6.4)	(7.16)	
MA 6450 MA 64100 ML 6425 ML 6450 MC 6450 MC 64100	250-0074	2-1/2-12	2.25	3.00	4.25	3.50	1.00	0.38	0.282	
			UN	(57.2)	(76.2)	(108.0)	(88.9)	(25.4)	(9.7)	(7.16)
MA 6450M MA 64100M ML 6425M ML 6450M MC 6450M MC 64100M	250-0075	M64x2	2.25	3.00	4.25	3.50	1.00	0.38	0.282	
			(57.2)	(76.2)	(108.0)	(88.9)	(25.4)	(9.7)	(7.16)	
MA 64150 MC 64150	250-0076	2-1/2-12	3.13	3.00	4.25	3.50	1.00	0.38	0.282	
			UN	(79.4)	(76.2)	(108.0)	(88.9)	(25.4)	(9.7)	(7.16)
MA 64150M MC 64150M	250-0077	M64x2	3.13	3.00	4.25	3.50	1.00	0.38	0.282	
		(79.4)	(76.2)	(108.0)	(88.9)	(25.4)	(9.7)	(9.7)	(7.16)	

Inches (mm)

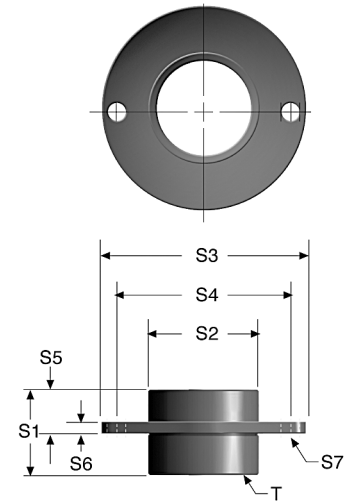

**Lock Nuts**

Used with	Part #	T	W	N3	
MA 33 ML 33 MC 33	250-0038	1-1/4-12	1.50	0.25	
			UN	(38.1)	(6.4)
MA 33M ML 33M MC 33M	250-0292	M33x1.5	1.56	0.25	
			(39.6)	(6.4)	
MA 36 ML 36 MC 36	250-0631	1-3/8-12	1.75	0.25	
			UNF	(44.5)	(6.4)
MA 36M ML 36M MC 36M	250-0537	M36x1.5	1.75	0.25	
			(44.5)	(6.4)	
MA 45 ML 45 MC 45	250-0041	1-3/4-12	2.25	0.37	
			UN	(57.2)	(9.4)
MA 45M ML 45M MC 45M	250-0297	M45x1.5	2.25	0.37	
			(57.2)	(9.4)	
MA 64 ML 64 MC 64	250-0042	2-1/2-12	3.00	0.37	
			UN	(76.2)	(9.4)
MA 64M ML 64M MC 64M	250-0302	M64x2	3.00	0.37	
			(76.2)	(9.4)	

Inches (mm)

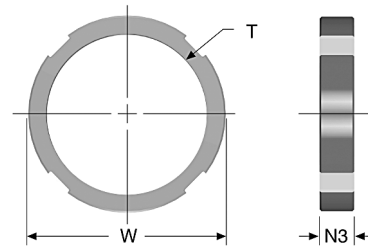

One lock nut included with each shock absorber where appropriate.

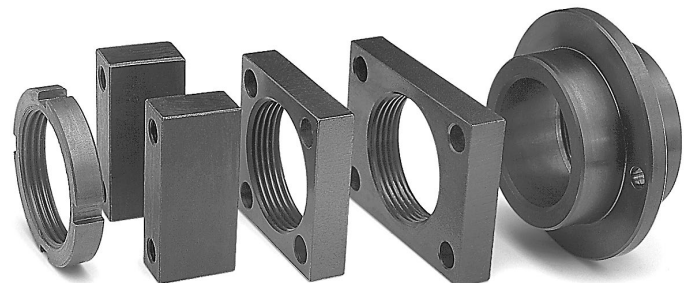

**Side-Foot Mount Assembly**



Used With	Part #	Used With	Part #
MA 33 ML 33 MC 33	250-0015	MA 6450 MA 64100 ML 6425 ML 6450 MC 6450 MC 64100	250-0030
MA 33M ML 33M MC 33M	250-0294		
MA 36 ML 36 MC 36	N/A	MA 6450M MA 64100M ML 6425M ML 6450M MC 6450M MC 64100M	250-0306
MA 36M ML 36M MC 36M	N/A		
MA 45 ML 45 MC 45	250-0025	MA 64150 MC 64150	250-0300
MA 45M ML 45M MC 45M	250-0300	MA 64150M MC 64150M	250-0306

**Clevis Mount Assembly**



Used With	Part #	Used With	Part #
MA 33 ML 33 MC 33 MAS MLS MCS	250-0225	ML 6425 ML 6425M MA 6450 ML 6450 MC 6450	250-0625 250-0626 250-0625
MA 33M ML 33M MC 33M MAS 33M MLS 33M MCS 33M	250-0323	MA 6450M ML 6450M MC 6450M	250-0626
MAN 33 MLN 33 MCN 33 MAA 33 MLA 33 MCA 33	250-0018	MA 64100 MC 64100 MAN 64150 MCN 64150 MAA 64150 MCA 64150	250-0625 250-0626 250-0625
MAN 33M MLN 33M MCN 33M MAA 33M MLA 33M MCA 33M	250-0322	MAN 64150M MCN 64150M MAA 64150M MCA 64150M	250-0626
MA 45 ML 45 MC 45	250-0324	MA 64150 MAS 64150 MCS 64150	250-0627
MA 45M ML 45M MC 45M	250-0325	MA 64150M MCA 64150M MAS 64150M MCS 64150M	250-0628





Fax completed form to 330-334-3335 or email to [actuatorsales@parker.com](mailto:actuatorsales@parker.com).

**CONTACT INFORMATION:**

Name \_\_\_\_\_ Phone \_\_\_\_\_  
 Company \_\_\_\_\_ email \_\_\_\_\_  
 City, State, Zip \_\_\_\_\_

**APPLICATION SKETCH**

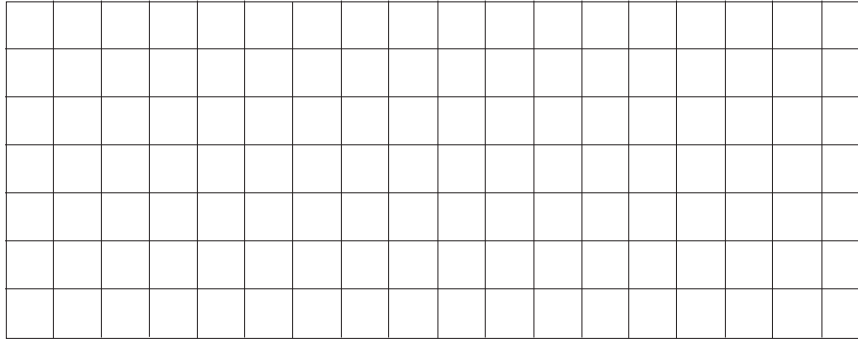

Please include the critical dimensions in your sketch.

In order to achieve the best solution, it is important that you provide as much information as possible.

For other considerations, please use another sheet of paper.

**OPERATING ENVIRONMENT**

**Media (check one)**

Air  Oil  
 Other \_\_\_\_\_

**Pressure**

Min. \_\_\_\_\_  
 Max. \_\_\_\_\_

**Temperature**

Ambient \_\_\_\_\_  
 Fluid \_\_\_\_\_

**Conditions**

Std. Factory  Chemical  
 Corrosive  Outdoor  
 Other \_\_\_\_\_

**TECHNICAL SPECIFICATIONS**

**Mounting/Cylinder Orientation**

Style (refer to catalog) \_\_\_\_\_  
 Vertical  Rod Up  Rod Down  
 Horizontal  
 Degrees from Vertical \_\_\_\_\_

**Port Type**

Head:  NPTF  BSPP  SAE  
 Cap:  NPTF  BSPP  SAE  
 Position # (refer to catalog) \_\_\_\_\_  
 Other \_\_\_\_\_

**Cushions**

Head:  Yes  No  
 Cap:  Yes  No  
 Position # (refer to catalog) \_\_\_\_\_

**Magnetic Piston**  Yes  No

**LOAD INFORMATION**

Push (lbs) \_\_\_\_\_ Extend Speed (inches/sec) \_\_\_\_\_ Dwell Time \_\_\_\_\_  
 Pull (lbs) \_\_\_\_\_ Retract Speed (inches/sec) \_\_\_\_\_ Cycles/Min \_\_\_\_\_  
 Known Side Load (lbs) \_\_\_\_\_

**ROD END DETAILS**

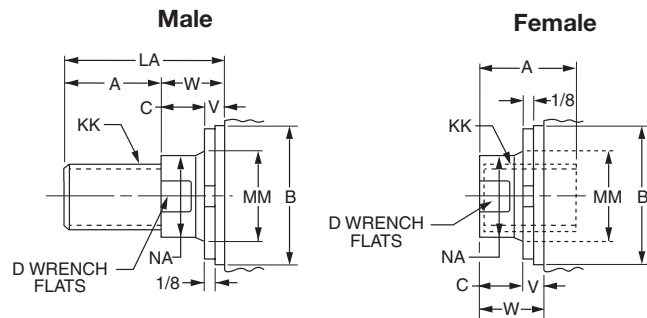

If rod end is different from above, please submit sketch. Piston rod diameter and rod end threads vary with the application. Please supply the dimensions below.

**Male Rod End**

KK = \_\_\_\_\_  
 A = \_\_\_\_\_  
 LA or LAF = \_\_\_\_\_

**Female Rod End**

KK = \_\_\_\_\_  
 A = \_\_\_\_\_  
 W or WF = \_\_\_\_\_

Check One	Rod End Connection	Case
<input type="checkbox"/>	Fixed and rigidly guided	
<input type="checkbox"/>	Pivoted and rigidly guided	
<input type="checkbox"/>	Supported but not rigidly guided	
<input type="checkbox"/>	Pivoted and rigidly guided	
<input type="checkbox"/>	Pivoted and rigidly guided	
<input type="checkbox"/>	Pivoted and rigidly guided	

Application Fax Forms  
 Part Number Index  
 Safety Guide  
 Offer of Sale  
 Application Fax Forms, Part Number Index, Safety Guide, Offer of Sale



For inventory, lead times, and kit lookup, visit [www.pdnplu.com](http://www.pdnplu.com)





Model No.	Section / Page No.	Model No.	Section / Page No.	Model No.	Section / Page No.	Model No.	Section / Page No.
240.....	G29	261109911.....	B114, B138	1347570038.....	K2	1493440005.....	C49
250.....	G30, M48	261109916.....	B114, B138	1347570044.....	K2	9126344341.....	L11
2010.....	G29, G81	261109917.....	B114, B138	1347570050.....	K2	9126344342.....	L11
2040.....	G81	261109918.....	B114, B138	1347570063.....	K2	9126344345.....	L11
3010.....	G29, G81	261109919.....	B114, B138	1347570075.....	K2	9126344346.....	L11
3325.....	M30	261109920.....	B114, B138	1347570088.....	K2	9126725404.....	B114, B138, C57
3350.....	M30	261109921.....	B114, B138	1347570100.....	K2	9126725405.....	B114, B138
3625.....	M30	261109922.....	B114, B138	1347570125.....	K2	9126725406.....	B114, B138, C56
3650.....	M30	683680000.....	B35, B79, B152	1442840000.....	K3	9126725407.....	C56
4525.....	M31	683690000.....	B35, B79	1458030044.....	B34, B35, B79, B80	9127385101.....	C56
4550.....	M31	683700000.....	B35, B79	1458030050.....	B34, B35, B79, B80	9127385121.....	C57
4575.....	M31	683710000.....	B35, B79	1458030075.....	B34, B35, B79, B80	9127385122.....	C57
6425.....	M32	683720000.....	B79	1458030088.....	B34, B35, B79, B80	9127385123.....	C57
6450.....	M32	695800000.....	B82, B86	1458030100.....	B34, B35, B79, B80	9127394521.....	B140
11052.....	G86	695810000.....	B82, B86	1458030125.....	B34, B35, B79, B80	9127394541.....	B115, B140
11053.....	G86	695820000.....	B82, B86	1458030150.....	B34, B35, B79, B80	9301054261.....	B111, B130, B135
11054.....	G86	695830000.....	B82, B86	1458040044.....	B34, B35, B79, B80	9301054262.....	B111, B130, B135
11055.....	G86	695900000.....	B82, B86	1458040050.....	B34, B35, B79, B80	9301054264.....	B111, B130, B135
11056.....	G86	695910000.....	B82, B86	1458040075.....	B34, B35, B79, B80	9301054266.....	B111, B130, B135
11057.....	G86	695920000.....	B82, B86	1458040088.....	B34, B35, B79, B80	086620R002.....	C48
11058.....	G86	695930000.....	B82, B86	1458040100.....	B34, B35, B79, B80	086620R005.....	C48
11059.....	G86	831830000.....	C65	1458040125.....	B34, B35, B79, B80	086620T002.....	C48
11060.....	G86	833010048.....	C65	1458040150.....	B34, B35, B79, B80	086620T005.....	C48
11061.....	G86	833010124.....	C65	1458040175.....	B34, B35, B79, B80	100-2801R.....	E42
11062.....	G86	849881100.....	C65	1458040200.....	B34, B35, B79, B80	10780-000.....	M44
11063.....	G86	856640044.....	B35	1458040225.....	B34, B35, B79, B80	10781-000.....	M44
11064.....	G86	856640050.....	B35, B79	1458040250.....	B34, B35, B79, B80	10782-000.....	M44
11065.....	G86	856640075.....	B35, B79	1458040275.....	B34, B35, B79, B80	10783-000.....	M44
11066.....	G86	856640100.....	B35, B79	1458040300.....	B34, B35, B79, B80	1-1/2 x 2.....	M33, M34
11067.....	G86	856640138.....	B35, B79	1458040325.....	B34, B35, B79, B80	1-1/2 x 3-1/2.....	M33, M34
11068.....	G86	856640175.....	B35, B79	1458040350.....	B34, B35, B79, B80	1-1/2 x 5.....	M33, M34
11069.....	G86	865130151.....	B83, B87	1458040375.....	B34, B35, B79, B80	1-1/2 x 6-1/2.....	M33, M34
11070.....	G86	865130200.....	B83, B87	1458040400.....	B34, B35, B79, B80	11089FIL.....	G86
11116.....	G86	865130250.....	B83, B87	1458040425.....	B34, B35, B79, B80	11090FIL.....	G86
64100.....	M32	865130325.....	B83, B87	1458040450.....	B34, B35, B79, B80, B152	11091FIL.....	G86
64150.....	M32	865130400.....	B83, B87	1458050050.....	B34, B35, B79, B80, B152	11092FIL.....	G86
109556.....	G104	865130500.....	B83, B87	1458050075.....	B34, B35, B79, B80, B152	11093FIL.....	G86
109559.....	G104	865130600.....	B83, B87	1458050100.....	B34, B35, B79, B80	11111x.....	G86
109560.....	G104	865130800.....	B83, B87	1458050125.....	B34, B35, B79, B80	11112x.....	G86
109561.....	G104	867340300.....	B114, B138	1458050150.....	B34, B35, B79, B80	11113x.....	G86
109562.....	G104	867340400.....	B114, B138	1458050175.....	B34, B35, B79, B80	11114x.....	G86
32510125.....	K4	867340600.....	B114, B138	1458050200.....	B34, B35, B79, B80	11115x.....	G86
32510250.....	K4	867340900.....	B114, B138	1458060050.....	B35, B79, B80, B152	11118x.....	G86
32510375.....	K4	876300100.....	K3	1458060075.....	B35, B79, B80, B152	11121x.....	G86
32510500.....	K4	876300200.....	K3	1458060100.....	B35, B79, B80	11122x.....	G86
32511215.....	K4	876300500.....	K3	1458060138.....	B35, B79, B80	11123x.....	G86
32511225.....	K4	876310100.....	K3	1458060175.....	B35, B79, B80	11124x.....	G86
32512525.....	K4	876310200.....	K3	1493440002.....	C49	11125x.....	G86
32512538.....	K4	876310300.....	K3	1493440003.....	C49	11126x.....	G86
32513838.....	K4	1337390125.....	K2	1493440004.....	C49	11128x.....	G86
68369000.....	B152	1337390150.....	K2			11131x.....	G86
116760000.....	B82, B86	1337390175.....	K2			11132x.....	G86
116770000.....	B82, B86	1337390188.....	K2			11133x.....	G86
117030000.....	B82, B86	1347570031.....	K2			11134x.....	G86

**Application**  
**Part Number**  
**Safety**  
**Offer of**  
**Application Fax Forms,**  
**Part Number Index, Safety**  
**Guide, Offer of Sale**



For inventory, lead times, and kit lookup, visit [www.pdnplu.com](http://www.pdnplu.com)



Model No.	Section / Page No.	Model No.	Section / Page No.	Model No.	Section / Page No.	Model No.	Section / Page No.
11135x.....	G86	20340FIL.....	G81, G84	20971FIL.....	G26	21210FIL.....	G89
11136x.....	G86	20349FIL.....	G81, G84	20976FIL.....	G81	21211FIL.....	G89
11138x.....	G86	20350FIL.....	G24, G81, G84	20977FIL.....	G81	21213FIL.....	G89
11141x.....	G86	20351FIL.....	G81	20PRL.....	K6, K7	21214FIL.....	G89
11142x.....	G86	20352FIL.....	G81	21107FIL.....	G68	21215FIL.....	G89
11143x.....	G86	20353FIL.....	G25, G81	21108FIL.....	G68	21216FIL.....	G89
11144x.....	G86	20354FIL.....	G81	21109FIL.....	G68	21217FIL.....	G89
11145x.....	G86	20355FIL.....	G81	21110FIL.....	G68	21218FIL.....	G89
11146x.....	G86	20356FIL.....	G25, G81	21119FIL.....	G83	21235FIL.....	G89
11148x.....	G86	20357FIL.....	G81	21120FIL.....	G83	21240x.....	G89
11822FIL.....	G86	20358FIL.....	G81	21121FIL.....	G83	21241x.....	G89
11823FIL.....	G86	20359FIL.....	G25, G81	21122FIL.....	G83	21257FIL.....	G73
11824FIL.....	G86	20360FIL.....	G81	21125FIL.....	G80	21260FIL.....	G73
11825FIL.....	G86	20361FIL.....	G81	21126FIL.....	G80	21290FIL.....	G67
11826FIL.....	G86	20362FIL.....	G25, G81	21127FIL.....	G80	21342BFIL.....	G76
11827FIL.....	G86	20363FIL.....	G81	21128FIL.....	G80	21342LFIL.....	G76
12PRL.....	K6, K7	20408FIL.....	G29, G81	21129FIL.....	G80	21343FIL.....	G76
13039FIL.....	G85	20432FIL.....	G31	21130FIL.....	G82	21344FIL.....	G76
16PRL.....	K6, K7	20433FIL.....	G32	21131FIL.....	G82	21346FIL.....	G76
20005FIL.....	G27	20434FIL.....	G30, G81	21132FIL.....	G82	250-0015.....	M50
20006FIL.....	G31	20435FIL.....	G30, G81	21133FIL.....	G82	250-0016.....	M48
20007FIL.....	G32	20436FIL.....	G81	21134FIL.....	G82	250-0018.....	M50
20008FIL.....	G30, G81	20437FIL.....	G81	21135FIL.....	G79	250-0023.....	M48
20009FIL.....	G30, G81	20438FIL.....	G31	21136FIL.....	G79	250-0024.....	M48
20024FIL.....	G27	20439FIL.....	G32	21137FIL.....	G79	250-0025.....	M50
20025FIL.....	G31	20446FIL.....	G28	21138FIL.....	G79	250-0028.....	M48
20026FIL.....	G32	20451FIL.....	G30, G81	21139FIL.....	G79	250-0030.....	M50
20027FIL.....	G30, G81	20452FIL.....	G30, G81	21140FIL.....	G79	250-0038.....	M49
20028FIL.....	G30, G81	20453FIL.....	G25, G81	21141FIL.....	G79	250-0040.....	M44
20037FIL.....	G28	20459FIL.....	G28	21142FIL.....	G82	250-0041.....	M49
20039FIL.....	G28	20462FIL.....	G27	21143FIL.....	G82	250-0042.....	M49
20092FIL.....	G27	20463FIL.....	G27	21144FIL.....	G82	250-0044.....	M44
20093FIL.....	G27	20464FIL.....	G81	21145FIL.....	G82	250-0070.....	M49
20094FIL.....	G27	20465FIL.....	G81	21146FIL.....	G82	250-0071.....	M49
20095FIL.....	G27	20466FIL.....	G27	21148FIL.....	G82	250-0072.....	M49
20096FIL.....	G27	20467FIL.....	G27	21149FIL.....	G82	250-0073.....	M49
20097FIL.....	G27	20477FIL.....	G27	21150FIL.....	G82	250-0074.....	M49
20157FIL.....	G30, G81	20478FIL.....	G27	21151FIL.....	G82	250-0075.....	M49
20158FIL.....	G30, G81	20480FIL.....	G30, G81	21158FIL.....	G73	250-0076.....	M49
20161FIL.....	G28	20482FIL.....	G30, G81	21159FIL.....	G73	250-0077.....	M49
20162FIL.....	G30, G81	20490FIL.....	G28	21186FIL.....	G67	250-0111.....	M45
20163FIL.....	G30, G81	2060FIL.....	G24, G81	21187FIL.....	G67	250-0112.....	M45
20166FIL.....	G28	20806FIL.....	G22	21188FIL.....	G67	250-0113.....	M45
20186FIL.....	G31	20807FIL.....	G22	21189FIL.....	G67	250-0207.....	M44
20187FIL.....	G32	20808FIL.....	G22	21196FIL.....	G61	250-0225.....	M50
20267FIL.....	G31	20809FIL.....	G22	21197FIL.....	G61	250-0231.....	M44
20268FIL.....	G32	20810FIL.....	G22	21198FIL.....	G61	250-0233.....	M44
20268FIL.....	G32	20811FIL.....	G22	21199FIL.....	G61	250-0239.....	M44
20311FIL.....	G79, G81	20819FIL.....	G25, G81	21200FIL.....	G61	250-0263.....	M44
20312FIL.....	G81	20821FIL.....	G24, G81	21201FIL.....	G61, G67	250-0271.....	M44
20313FIL.....	G79, G81	20822FIL.....	G24, G81	21202FIL.....	G61, G67, G73	250-0272.....	M44
20314FIL.....	G81	20849FIL.....	G33	21203FIL.....	G61, G67, G73	250-0275.....	M44
20338FIL.....	G81, G84	20850FIL.....	G33	21204FIL.....	G61, G67, G73	250-0276.....	M44
20339FIL.....	G24, G81	20851FIL.....	G33	21205FIL.....	G61, G67, G73	250-0292.....	M49

Application  
 Fax Forms  
 Part Number  
 Index  
 Safety  
 Guide  
 Offer of  
 Sale  
 Application Fax Forms,  
 Part Number Index, Safety  
 Guide, Offer of Sale  
**N**



For inventory, lead times, and kit lookup, visit [www.pdnplu.com](http://www.pdnplu.com)





Model No.	Section / Page No.	Model No.	Section / Page No.	Model No.	Section / Page No.	Model No.	Section / Page No.
KF40	G62, G64	L067930000	C66, C67	L073790124	C33	L077160132	C37
KF50	G62, G64	L067940000	C66, C67	L073790125	C47	L077170500	C33
KS05LPL251	D5, D10	L067950000	C66	L073790132	C33	L077170800	C33, C37
KS05LPL255	D5, D10	L067960000	C66	L073790140	C33, C47	L077170900	C33, C37
KS07LPL311	D5, D10	L067970000	C66	L073800200	C33	L077171200	C33, C37
KS07LPL315	D5, D10	L067980000	C66	L073800400	C33	L077171400	C37
KS12LPL501	D5, D10	L067990000	C66	L073800500	C33	L078930016	G102
KS12LPL505	D5, D10	L069190000	C65	L073800600	C33	L079020016	G92
KS15LPL621	D5, D10	L069200000	C65	L073800800	C33	L079020020	G92
KS15LPL625	D5, D10	L069210000	C65	L073800900	C33	L079700150	B34, B81
KS20LPL751	D5, D10	L069220000	C65	L073801000	C47	L079700200	B34, B81
KS20LPL755	D5, D10	L069230000	C65	L073801100	C33	L079700250	B34, B81
KS25LPL751	D5, D10	L069240000	C65	L073801200	C33, C47	L079700325	B34, B81
KS25LPL755	D5, D10	L069250000	C65	L073801300	C47	L079700400	B34, B81
KS30LPL871	D5, D10	L069260000	C65	L073801400	C33, C47	L079700500	B34, B81
KS30LPL875	D5, D10	L06998 0000	K3	L073801500	C33, C47	L079710150	B34, B81
KS40LPL101	D5, D10	L071300025	C32	L073810008	D10	L079710200	B34, B81
KS40LPL105	D5, D10	L071300100	C32	L073810010	D10	L079710250	B34, B81
		L071300200	C32	L073810020	D10	L079710325	B34, B81
		L071300300	C32	L073810024	D10	L079710400	B34, B81
		L071300350	C47	L073810032	D10	L079710500	B34, B81
		L071300400	C32, C47	L073810040	D10	L079720150	B34, B81
		L071300500	C32	L073810048	D10	L079720200	B34, B81
		L071300550	C47	L073820012	D10	L079720250	B34, B81
		L071300600	C32, C47	L073820024	D10	L079720325	B34, B81
		L071310100	C32	L073820040	D10	L079720400	B34, B81
		L071310200	C32	L073830012	D10	L079730150	B34, B81
		L071310300	C32	L073830024	D10	L079730200	B34, B81
		L071310400	C47	L073830040	D10	L079730250	B34, B81
		L071310500	C47	L073840016	D10	L079730325	B34, B81
		L071310600	C47	L073840020	D10	L079730400	B34, B81
		L071310700	C47	L073840024	D10	L079730500	B34, B81
		L071320025	C32	L075400032	B110	L079740150	B34, B81
		L071320100	C32	L075400050	B110	L079740200	B34, B81
		L071320200	C32	L075400063	B110	L079740250	B34, B81
		L071320250	C47	L075400125	B110	L079740325	B34, B81
		L071320300	C32	L075400160	B110	L079740400	B34, B81
		L071320350	C47	L075490036	B113	L079740500	B34, B81
		L071320400	C32	L075540036	B114, B138	L079750150	B34, B81
		L071320450	C47	L076600100	C32	L079750200	B34, B81
		L071320500	C32	L076600200	C32	L079750250	B34, B81
		L071320550	C47	L077130100	C32	L079750325	B34, B81
		L071320600	C32	L077130200	C32, C37	L079750400	B34, B81
		L073790016	C33	L077130300	C32, C37	L080100025	G92
		L073790023	C33	L077130400	C32, C37	L080100032	G92
		L073790024	C33	L077130500	C32, C37	L080100040	G92
		L073790028	C33	L077150100	C32	L080100050	G92
		L073790032	C33	L077150200	C32, C37	L080100063	G92
		L073790040	C33	L077150400	C32, C37	L080160020	G102
		L073790048	C33	L077150500	C37	L080160025	G102
		L073790056	C47	L077160028	C33	L080160032	G102
		L073790102	C33	L077160040	C33, C37	L080160040	G102
		L073790108	C47	L077160048	C33, C37	L080160050	G102
		L073790116	C47	L077160124	C33, C37	L080160063	G102

**L**

Application Fax Forms

Part Number Index

Safety Guide

Offer of Sale

Application Fax Forms, Part Number Index, Safety Guide, Offer of Sale

**N**



For inventory, lead times, and kit lookup, visit [www.pdnplu.com](http://www.pdnplu.com)



Model No.	Section / Page No.	Model No.	Section / Page No.	Model No.	Section / Page No.	Model No.	Section / Page No.
L08016M020.....	G102	MA 900 .....	M24, M25, M44, M45	MC 4575 .....	M27	ML 45M.....	M48, M49, M50
L08016M025.....	G102	MA 900M .....	M25, M44, M45	MC 45M .....	M48, M49, M50	ML 64.....	M48, M49
L08016M032.....	G102	MAA 33 .....	M50	MC 600 .....	M18, M19, M44, M45	ML 6425.....	M29, M48, M49, M50
L08016M040.....	G102	MAA 33M .....	M50	MC 600H .....	M18, M19	ML 6425M.....	M48, M49, M50
L08016M050.....	G102	MAA 64150 .....	M48, M50	MC 600H2 .....	M18, M19	ML 645.....	M29
L08016M063.....	G102	MAA 64150M .....	M48, M50	MC 600M .....	M19, M44, M45, M47	ML 6450.....	M29, M48, M49, M50
L080180016.....	G101	MAN 33.....	M50	MC 600ML .....	M19	ML 6450M.....	M48, M49, M50
L080180020.....	G101	MAN 33M.....	M50	MC 64 .....	M48, M49	ML 64M.....	M48, M49
L080180025.....	G101	MAN 64150 .....	M50	MC 64100 .....	M27, M48, M49, M50	MLA 33 .....	M50
L080180032.....	G101	MAN 64150M .....	M50	MC 64100M .....	M48, M49, M50	MLA 33M .....	M50
L080180040.....	G101	MAS .....	M50	MC 64150 .....	M27, M48, M49, M50	MLN 33 .....	M50
L080180050.....	G101	MAS 33M .....	M50	MC 64150M .....	M48, M49, M50	MLN 33M .....	M50
L080180063.....	G101	MAS 64150 .....	M50	MC 6450 .....	M27, M48, M49, M50	MLS .....	M50
L080190016.....	G101	MAS 64150M .....	M50	MC 6450M .....	M48, M49, M50	MLS 33M .....	M50
L080190020.....	G101	MB-PL25.....	G55, G56	MC 64M .....	M48, M49	MUP25 .....	G83
L080190025.....	G101	MB-PL32.....	G55, G56	MC 64MH .....	M48, M49	MUP32 .....	G83
L080190032.....	G101	MB-PL40.....	G55, G56	MC 75 .....	M16, M17, M44	MUP40 .....	G83
LP/LPM Series .....	D2	MB-PL50.....	G55, G56	MC 75M .....	M17, M44	MUP50 .....	G83
		MB-SL25.....	G46, G47	MC 9 .....	M16	MVC 225 .....	M44, M45
		MB-SL32.....	G46, G47	MC 9M .....	M17	MVC 225M .....	M44, M45
		MB-SL40.....	G46, G47	MC 150M-B .....	G61, G67, G73	MVC 225M-880* .....	M47
		MB-SL50.....	G46, G47	MC 150MH-B.....	G61, G67, G73	MVC 600 .....	M44, M45
		MB-SL63.....	G46, G47	MC225M .....	G61, G67, G73	MVC 600M .....	M44, M45
		MB-SL80.....	G46, G47	MC225MH .....	G61, G67, G73	MVC 600M-880* .....	M47
		MC 10E.....	M17, M44	MC25M .....	G61, G67	MVC 900 .....	M44, M45
		MC 10H .....	M16, M17	MC25MH .....	G61, G67	MVC 900M.....	M45
		MC 10L .....	M16, M17	MC600M .....	G61, G67, G73		
		MC 10M.....	M17, M44	MC600MH .....	G61, G67, G73, G104		
		MC 150 .....	M18, M19, M44, M45	MC600ML .....	M44	<b>O</b>	
		MC 150* .....	M45	MC75M .....	G61, G67, G73	OSP-HD25 .....	G73
		MC 150H .....	M18, M19	MCA 33.....	M50	OSP-HD32 .....	G73
		MC 150H2 .....	M18, M19	MCA 33M.....	M50	OSP-HD40 .....	G73
		MC 150M .....	M19, M44, M45, M47	MCA 64150.....	M48, M50	OSP-HD50 .....	G73
		MC 150ME.....	M19	MCA 64150M.....	M48, M50	OSP-KF16.....	G67
		MC 225 .....	M18, M19, M44, M45	MCN 33 .....	M50	OSP-KF25.....	G67
		MC 225H .....	M18, M19	MCN 33M .....	M50	OSP-KF32.....	G67
		MC 225H2 .....	M18, M19	MCN 64150 .....	M50	OSP-KF40.....	G67
		MC 225M .....	M19, M44, M45, M47	MCN 64150M .....	M50	OSP-KF50.....	G67
		MC 225ME.....	M19	MCS .....	M50	OSP-P 25.....	G89
		MC 25 .....	M16, M17, M44	MCS 33M.....	M50	OSP-P 32.....	G89
		MC 25H .....	M16	MCS 64150.....	M50	OSP-P 40.....	G89
		MC 25L.....	M16, M17	MCS 64150M.....	M50	OSP-P 50.....	G89
		MC 25M.....	M17, M44	ML 33.....	M48, M49, M50	OSP-P 63.....	G89
		MC 33 .....	M48, M49, M50	ML 3325.....	M29	OSP-P 80.....	G89
		MC 3325 .....	M27	ML 3350.....	M29	OSP-P Active Brake .....	G22
		MC 3350 .....	M27	ML 33M.....	M48, M49, M50	OSP-P Bi-Parting .....	G38
		MC 33M .....	M48, M49, M50	ML 36.....	M48, M49, M50	OSP-P Clean Room .....	G34
		MC 36 .....	M48, M49, M50	ML 3625.....	M29	OSP-P HD.....	G69
		MC 3625 .....	M27	ML 3650.....	M29	OSP-P KF .....	G62
		MC 3650 .....	M27	ML 36M.....	M48, M49, M50	OSP-P KF16 .....	G79
		MC 36M .....	M48, M49, M50	ML 45.....	M48, M49, M50	OSP-P KF25 .....	G79
		MC 45 .....	M48, M49, M50	ML 4525.....	M29	OSP-P KF32 .....	G79
		MC 4525 .....	M27	ML 4550.....	M29	OSP-P KF40 .....	G84
		MC 4550 .....	M27			OSP-P KF50 .....	G84
						OSP-P Linear Guides .....	G41

**M**

MA 150 .....

MA 150M .....

MA 150ME .....

MA 225 .....

MA 225M .....

MA 225M-880\* .....

MA 33 .....

MA 3325 .....

MA 3350 .....

MA 33M .....

MA 35 .....

MA 35M .....

MA 36 .....

MA 3625 .....

MA 3650 .....

MA 36M .....

MA 45 .....

MA 4525 .....

MA 4550 .....

MA 4575 .....

MA 45M .....

MA 600 .....

MA 600M .....

MA 600M-880\* .....

MA 64 .....

MA 64100 .....

MA 64100M .....

MA 64150 .....

MA 64150M .....

MA 6450 .....

MA 6450M .....

MA 64M .....



For inventory, lead times, and kit lookup, visit [www.pdnplu.com](http://www.pdnplu.com)

Application  
Fax Forms

Part Number  
Index

Safety  
Guide

Offer of  
Sale

Application Fax Forms,  
Part Number Index, Safety  
Guide, Offer of Sale

**N**

Model No.	Section / Page No.	Model No.	Section / Page No.	Model No.	Section / Page No.	Model No.	Section / Page No.
OSP-P POWERSLIDE .....	G48	P1A-4DMJ .....	C56	P1C-4LMSB....	B108, B130, B132	P1C-4QMDB.....	B108, B130, B132
OSP-P PROLINE .....	G52	P1A-4DMT .....	C57	P1C-4LMTB....	B109, B130, B133	P1C-4QMEB .....	B109, B130, B133
OSP-P Series .....	G2, G4, G6, G7, G8, G9	P1A-4DRC .....	C57	P1C-4LRC.....	B113, B130	P1C-4QMF.....	B107, B130, B131
OSP-P SLIDELINE.....	G43	P1A-4DRS.....	C57	P1C-4LRF .....	B114, B130, B138	P1C-4QMSB .....	B108, B130, B132
OSP-P Standard.....	G10	P1A-4HMB.....	C56	P1C-4LRS.....	B113, B130, B137	P1C-4QMTB .....	B109, B130, B133
OSP-P STARLINE.....	G57	P1A-4HMF .....	C56	P1C-4MMAF .....	B111, B130, B134	P1C-4RMAF....	B111, B130, B134
OSP-P STL16.....	G79	P1A-4HMJ .....	C56	P1C-4MMB....	B107, B130, B131	P1C-4RMB.....	B107, B130, B131
OSP-P STL25.....	G79	P1A-4HMT .....	C57	P1C-4MMCB .....	B110, B130, B134	P1C-4RMBBA .....	K7
OSP-P STL32.....	G79	P1A-4HRC .....	C57	P1C-4MMDB.....	B108, B130, B132	P1C-4RMCB .....	B110, B130, B134
OSP-P STL32.....	G79	P1A-4HRS .....	C57	P1C-4MMEB.....	B109, B130, B133	P1C-4RMDB .....	B108, B130, B132
OSP-P STL40.....	G84	P1A-4JRC .....	C57	P1C-4MMF ....	B107, B130, B131	P1C-4RMEB .....	B109, B130, B133
OSP-P STL50.....	G84	P1A-4JRS .....	C57	P1C-4MMSB.....	B108, B130, B132	P1C-4RMF .....	B107, B130, B131
OSP-P10.....	G5, G6, G10, G14, G16, G26, G29, G30	P1A-S 010 .....	C51, C52	P1C-4MMTB.....	B109, B130, B133	P1C-4RMSB .....	B108, B130, B132
OSP-P16.....	G5, G6, G10, G14, G17, G18, G19, G27, G28, G29, G30, G31, G32, G33, G34, G36, G37, G78, G81, G85	P1A-S 010 D.....	C53	P1C-4MRC .....	B113, B130	P1C-4RMTB....	B109, B130, B133
OSP-P25.....	G5, G6, G10, G14, G17, G18, G19, G21, G27, G28, G29, G30, G31, G32, G33, G34, G36, G37, G78, G81, G85, G88	P1A-S 010 SS.....	C51, C52, C53	P1C-4MRF .....	B114, B130, B138	P1C-4RRC .....	B113, B130
OSP-P32.....	G5, G6, G10, G14, G17, G18, G19, G21, G27, G28, G29, G30, G31, G32, G33, G36, G37, G78, G81, G85, G88	P1A-S 012 .....	C51, C52	P1C-4MRS.....	B113, B130, B137	P1C-4RRF.....	B114, B130, B138
OSP-P40.....	G5, G6, G10, G14, G17, G18, G19, G21, G27, G28, G29, G30, G31, G32, G33, G78, G81, G85, G88	P1A-S 012 D.....	C53	P1C-4NMAF....	B111, B130, B134	P1C-4RRS .....	B113, B130, B137
OSP-P50.....	G5, G6, G10, G14, G17, G18, G19, G21, G27, G28, G29, G30, G31, G32, G33, G78, G81, G85, G88	P1A-S 012 SS.....	C51, C52, C53	P1C-4NMB ....	B107, B130, B131	P1C-4SMB.....	B107
OSP-P63.....	G5, G6, G10, G14, G17, G18, G19, G27, G28, G29, G30, G78, G81, G85, G88	P1A-S 016 .....	C51, C52	P1C-4NMBA .....	K7	P1C-4SMDDB .....	B108
OSP-P80.....	G5, G6, G10, G14, G17, G18, G19, G27, G28, G29, G30, G31, G32, G33, G78, G81, G85, G88	P1A-S 016 D.....	C53	P1C-4NMDB.....	B110, B130, B134	P1C-4SMEB.....	B109
OSP-P63.....	G5, G6, G10, G14, G17, G18, G19, G27, G28, G29, G30, G78, G81, G85, G88	P1A-S 016 M .....	C51, C52, C53	P1C-4SMF .....	B107	P1C-4SMSB .....	B108
OSP-P80.....	G5, G6, G10, G14, G17, G18, G19, G27, G28, G29, G30, G31, G32, G33, G78, G81, G85, G88	P1A-S 016 SS(TS).....	C51, C52, C53	P1C-4NMDB.....	B108, B130, B132	P1C-4SMTB.....	B109
OSP-STL16.....	G61	P1A-S 020 .....	C51, C52	P1C-4NMEB .....	B109, B130, B133	P1C-4SRF .....	B114
OSP-STL25.....	G61	P1A-S 020 D.....	C53	P1C-4NMF .....	B107, B130, B131	P1C-4SRS .....	B113
OSP-STL32.....	G61	P1A-S 020 M .....	C51, C52, C53	P1C-4NMSB .....	B108, B130, B132	P1C-4TMB .....	B107
OSP-STL40.....	G61	P1A-S 020 SS(TS).....	C51, C52, C53	P1C-4NMTB .....	B109, B130, B133	P1C-4TMDB.....	B108
OSP-STL50.....	G61	P1A-S 025 .....	C51, C52	P1C-4NMAF....	B111, B130, B134	P1C-4TMEB.....	B109
		P1A-S 025 D.....	C53	P1C-4PMB.....	B107, B130, B131	P1C-4TMF .....	B107
		P1A-S 025 M .....	C51, C52, C53	P1C-4PMCB .....	B110, B130, B134	P1C-4TMSB.....	B108
		P1A-S 025 SS(TS).....	C51, C52, C53	P1C-4PMDB .....	B108, B130, B132	P1C-4TMTB.....	B109
		P1C-4KMAF....	B111, B130, B134	P1C-4PMEB....	B109, B130, B133	P1D Series .....	B91
		P1C-4KMB.....	B107, B130, B131	P1C-4PMF .....	B107, B130, B131	P1D-4KMYF ....	B112, B130, B136
		P1C-4KMBA .....	K7	P1C-4PMSB .....	B108, B130, B132	P1D-4LMYF ....	B112, B130, B136
		P1C-4KMCB.....	B110, B130, B134	P1C-4PMTB....	B109, B130, B133	P1D-4MMYF .....	B112, B130, B136
		P1C-4KMDB .....	B108, B130, B132	P1C-4PRC .....	B113, B130	P1D-4NMYF ....	B112, B130, B136
		P1C-4KMEB....	B109, B130, B133	P1C-4PRF .....	B114, B130, B138	P1D-4PMYF ....	B112, B130, B136
		P1C-4KMF .....	B107, B130, B131	P1C-4PRS .....	B113, B130, B137	P1E-6KB0 .....	B111, B130, B135
		P1C-4KMSB .....	B108, B130, B132	P1C-4QMAF....	B111, B130, B134	P1E-6LB0 .....	B111, B130, B135
		P1C-4KMTB....	B109, B130, B133	P1C-4QMB .....	B107, B130, B131	P1E-6MB0 .....	B111, B130, B135
		P1C-4KRRC .....	B113, B130	P1C-4QMBBA .....	K7	P1E-6NB0.....	B111, B130, B135
		P1C-4KRF.....	B114, B130, B138	P1C-4QMDB.....	B110, B130, B132	P1E-6PB0 .....	B111, B130, B135
		P1C-4KRS .....	B113, B130, B137	P1C-4QMEB .....	B109, B130, B133	P1E-6QB0.....	B111, B130, B135
		P1C-4KRS .....	B113, B130, B137	P1C-4QMF.....	B107, B130, B131	P1F-4KMY .....	B136
		P1C-4LMAF ....	B111, B130, B134	P1C-4QMSB .....	B108, B130, B132	P1F-4KMYT .....	B136
		P1C-4LMB .....	B107, B130, B131	P1C-4QMTB .....	B109, B130, B133		
		P1C-4LMBA.....	K7	P1C-4RMAF....	B111, B130, B134		
		P1C-4LMCB....	B110, B130, B134	P1C-4RMB.....	B107, B130, B131		
		P1C-4LMDB....	B108, B130, B132	P1C-4RMBBA .....	K7		
		P1C-4LMEB....	B109, B130, B133	P1C-4RMCB .....	B110, B130, B134		
		P1C-4LMF.....	B107, B130, B131	P1C-4RMDB .....	B108, B130, B132		

**P**



For inventory, lead times, and kit lookup, visit [www.pdnplu.com](http://www.pdnplu.com)

Application Fax Forms, Part Number Index, Safety Guide, Offer of Sale, Application Fax Forms, Part Number Index, Safety Guide, Offer of Sale



Model No.	Section / Page No.	Model No.	Section / Page No.	Model No.	Section / Page No.	Model No.	Section / Page No.
P1F-4LMY	B136	P1F-6125RV	B140	P1F-S080MC-0320-0000	B118	P1VAS020 A*070	J15
P1F-4LMYT	B136	P1F-S032MC-0025-0000	B118	P1F-S080MC-0400-0000	B118	P1VAS020 A*140	J15
P1F-4MMY	B136	P1F-S032MC-0040-0000	B118	P1S-4JRD	B113, B130, B137	P1VAS020 A*240	J15
P1F-4MMYT	B136	P1F-S032MC-0050-0000	B118	P1S-4JRT	B113, B137	P1VAS020 A*460	J15
P1F-4NMY	B136	P1F-S032MC-0080-0000	B118	P1S-4LRD	B113, B130, B137	P1VAS020 A*G00	J15
P1F-4NMYT	B136	P1F-S032MC-0100-0000	B118	P1S-4LRT	B113, B137	P1VAS020A*	J19
P1F-4PMY	B136	P1F-S032MC-0125-0000	B118	P1S-4MRD	B113, B130, B137	P1VAS020A*005	J14, J19
P1F-4PMYT	B136	P1F-S032MC-0160-0000	B118	P1S-4MRT	B113, B137	P1VAS020A*018	J14, J19
P1F-4QMY	B136	P1F-S032MC-0200-0000	B118	P1S-4PRD	B113, B130, B137	P1VAS020A*036	J14, J19
P1F-4QMYT	B136	P1F-S032MC-0250-0000	B118	P1S-4PRT	B113, B137	P1VAS020A*070	J14, J19
P1F-4RMY	B136	P1F-S032MC-0320-0000	B118	P1S-4RRD	B113, B130, B137	P1VAS020A*140	J14, J19
P1F-4RMYT	B136	P1F-S032MC-0400-0000	B118	P1S-4RRT	B113, B137	P1VAS020A*240	J14, J19
P1F-6032RF	B140	P1F-S040MC-0025-0000	B118	P1V	J13	P1VAS020A*460	J14, J19
P1F-6032RL	B140	P1F-S040MC-0040-0000	B118	P1VAS Series	J2	P1VAS020A*G00	J14, J19
P1F-6032RN	B140	P1F-S040MC-0050-0000	B118	P1VAS012	J13, J24	P1VAS020A0005	J18
P1F-6032RNL	B140	P1F-S040MC-0080-0000	B118	P1VAS012 A*010	J15	P1VAS020A0018	J18
P1F-6032RNL	B140	P1F-S040MC-0100-0000	B118	P1VAS012 A*060	J15	P1VAS020A0036	J18
P1F-6032RQ	B140	P1F-S040MC-0125-0000	B118	P1VAS012 A*090	J15	P1VAS020A0070	J18
P1F-6032RV	B140	P1F-S040MC-0160-0000	B118	P1VAS012 A*140	J15	P1VAS020A0140	J18
P1F-6040RF	B140	P1F-S040MC-0200-0000	B118	P1VAS012 A*360	J15	P1VAS020A0240	J18
P1F-6040RL	B140	P1F-S040MC-0250-0000	B118	P1VAS012 A*550	J15	P1VAS020A0460	J18
P1F-6040RN	B140	P1F-S040MC-0320-0000	B118	P1VAS012 A*N00	J15	P1VAS020A0G00	J18
P1F-6040RNL	B140	P1F-S040MC-0400-0000	B118	P1VAS012A*010	J14, J17	P1VAS020D*005	J15
P1F-6040RQ	B140	P1F-S050MC-0025-0000	B118	P1VAS012A*060	J14, J17	P1VAS020D*018	J15
P1F-6040RV	B140	P1F-S050MC-0040-0000	B118	P1VAS012A*090	J14, J17	P1VAS020D*036	J15
P1F-6050RF	B140	P1F-S050MC-0050-0000	B118	P1VAS012A*140	J14, J17	P1VAS020D*070	J15
P1F-6050RL	B140	P1F-S050MC-0080-0000	B118	P1VAS012A*360	J14, J17	P1VAS020D*140	J15
P1F-6050RN	B140	P1F-S050MC-0100-0000	B118	P1VAS012A*550	J14, J17	P1VAS020D*240	J15
P1F-6050RNL	B140	P1F-S050MC-0125-0000	B118	P1VAS012A*N00	J14, J17	P1VAS020D*460	J15
P1F-6050RQ	B140	P1F-S050MC-0160-0000	B118	P1VAS012A0010	J16	P1VAS020D*G00	J15
P1F-6050RV	B140	P1F-S050MC-0200-0000	B118	P1VAS012A0060	J16	P1VAS020D0005	J18
P1F-6063RF	B140	P1F-S050MC-0250-0000	B118	P1VAS012A0090	J16	P1VAS020D0018	J18
P1F-6063RL	B140	P1F-S050MC-0320-0000	B118	P1VAS012A0140	J16	P1VAS020D0036	J18
P1F-6063RN	B140	P1F-S050MC-0400-0000	B118	P1VAS012A0360	J16	P1VAS020D0070	J18
P1F-6063RNL	B140	P1F-S063MC-0025-0000	B118	P1VAS012A0550	J16	P1VAS020D0140	J18
P1F-6063RQ	B140	P1F-S063MC-0040-0000	B118	P1VAS012A0N00	J16	P1VAS020D0240	J18
P1F-6063RV	B140	P1F-S063MC-0050-0000	B118	P1VAS012D*010	J15	P1VAS020D0460	J18
P1F-6080RF	B140	P1F-S063MC-0080-0000	B118	P1VAS012D*060	J15	P1VAS020D0G00	J18
P1F-6080RL	B140	P1F-S063MC-0100-0000	B118	P1VAS012D*090	J15	P1VAS030	J13, J24
P1F-6080RN	B140	P1F-S063MC-0125-0000	B118	P1VAS012D*140	J15	P1VAS030 A*005	J15
P1F-6080RNL	B140	P1F-S063MC-0160-0000	B118	P1VAS012D*360	J15	P1VAS030 A*010	J15
P1F-6080RQ	B140	P1F-S063MC-0200-0000	B118	P1VAS012D*550	J15	P1VAS030 A*018	J15
P1F-6080RV	B140	P1F-S063MC-0250-0000	B118	P1VAS012D*N00	J15	P1VAS030 A*036	J15
P1F-6100RF	B140	P1F-S063MC-0320-0000	B118	P1VAS012D0010	J16	P1VAS030 A*070	J15
P1F-6100RL	B140	P1F-S063MC-0400-0000	B118	P1VAS012D0060	J16	P1VAS030 A*123	J15
P1F-6100RN	B140	P1F-S080MC-0025-0000	B118	P1VAS012D0090	J16	P1VAS030 A*240	J15
P1F-6100RNL	B140	P1F-S080MC-0040-0000	B118	P1VAS012D0140	J16	P1VAS030 A*460	J15
P1F-6100RQ	B140	P1F-S080MC-0050-0000	B118	P1VAS012D0360	J16	P1VAS030 A*E50	J15
P1F-6100RV	B140	P1F-S080MC-0080-0000	B118	P1VAS012D0550	J16	P1VAS030A*	J19
P1F-6125RF	B140	P1F-S080MC-0100-0000	B118	P1VAS012D0N00	J16	P1VAS030A*005	J14, J19
P1F-6125RL	B140	P1F-S080MC-0125-0000	B118	P1VAS020	J13, J24	P1VAS030A*010	J14, J19
P1F-6125RN	B140	P1F-S080MC-0160-0000	B118	P1VAS020 A*005	J15	P1VAS030A*018	J14, J19
P1F-6125RNL	B140	P1F-S080MC-0200-0000	B118	P1VAS020 A*018	J15	P1VAS030A*036	J14, J19
P1F-6125RQ	B140	P1F-S080MC-0250-0000	B118	P1VAS020 A*036	J15	P1VAS030A*070	J14, J19

Application  
Fax Forms

Part Number  
Index

Safety  
Guide

Offer of  
Sale

Application Fax Forms,  
Part Number Index, Safety  
Guide, Offer of Sale

**N**



For inventory, lead times, and kit lookup, visit [www.pdnplu.com](http://www.pdnplu.com)

Model No.	Section / Page No.	Model No.	Section / Page No.	Model No.	Section / Page No.	Model No.	Section / Page No.
P1VAS030A*123	J14, J19	P1VAS060A0070	J20	P1VAS6/1191563C	J25	P5GM	F2, F14, F15, F16
P1VAS030A*240	J14, J19	P1VAS060A0200	J20	P1VAS6/1191564*	J25	P5GM-010	F15, F16
P1VAS030A*460	J14, J19	P1VAS060A0300	J20	P1VAS6/1191564B	J25	P5GM-010MSG005B	F14
P1VAS030A*E50	J14, J19	P1VAS060A0400	J20	P1VAS6/1191654C	J25	P5GM-010MSG006B	F14
P1VAS030A0005	J18	P1VAS060A0550	J20	P1VAS6/4447851*	J25	P5GM-010MSG010B	F14
P1VAS030A0010	J18	P1VAS090	J13, J24	P1VAS6/4447851F	J25	P5GM-014	F15, F16
P1VAS030A0018	J18	P1VAS090 A*031	J15	P1VAS6/4447853*	J25	P5GM-014MSG006B	F14
P1VAS030A0036	J18	P1VAS090 A*047	J15	P1VAS6/4447853B	J25	P5GM-014MSG010B	F14
P1VAS030A0070	J18	P1VAS090 A*065	J15	P1VAS6/4447854*	J25	P5GM-014MSG013B	F14
P1VAS030A0123	J18	P1VAS090 A*190	J15	P1VAS6/4447854B	J25	P5GM-022	F15, F16
P1VAS030A0240	J18	P1VAS090 A*285	J15	P1VAS6/4447861*	J25	P5GM-022MSG010B	F14
P1VAS030A0460	J18	P1VAS090 A*367	J15	P1VAS6/4447861M	J25	P5GM-022MSG013B	F14
P1VAS030A0E50	J18	P1VAS090 A*520	J15	P1VAS6/4447863*	J25	P5GM-022MSG019B	F14
P1VAS030D*005	J15	P1VAS090 A*C60	J15	P1VAS6/4447863B	J25	P5GM-032	F15, F16
P1VAS030D*010	J15	P1VAS090A*	J20, J22	P1VAS6/4447864*	J25	P5GM-032MSG013B	F14
P1VAS030D*018	J15	P1VAS090A*031	J14, J22	P1VAS6/4447864B	J25	P5GM-032MSG019B	F14
P1VAS030D*036	J15	P1VAS090A*047	J14, J22	P1VAS6/4447871*	J25	P5GM-032MSG032B	F14
P1VAS030D*070	J15	P1VAS090A*065	J14, J22	P1VAS6/4447871L	J25	P5GN	F2, F11, F12, F13
P1VAS030D*123	J15	P1VAS090A*190	J14, J22	P1VAS6/4447871M	J25	P5GN-012	F12, F13
P1VAS030D*240	J15	P1VAS090A*285	J14, J22	P1VAS6/4447873*	J25	P5GN-012MSG001B	F11
P1VAS030D*460	J15	P1VAS090A*367	J14, J22	P1VAS6/4447873C	J25	P5GN-012MSG002B	F11
P1VAS030D*E50	J15	P1VAS090A*520	J14, J22	P1VAS6/4447873D	J25	P5GN-012MSG003B	F11
P1VAS030D0005	J18	P1VAS090A*C60	J14	P1VAS6/4447874*	J25	P5GN-014	F12, F13
P1VAS030D0010	J18	P1VAS090A0031	J20	P1VAS6/4447874C	J25	P5GN-014MSG002B	F11
P1VAS030D0018	J18	P1VAS090A0047	J20	P1VAS6/4447874D	J25	P5GN-014MSG003B	F11
P1VAS030D0036	J18	P1VAS090A0065	J20	P1VAS6/4447881*	J25	P5GN-014MSG005B	F11
P1VAS030D0070	J18	P1VAS090A0190	J20	P1VAS6/4447881C	J25	P5GN-022	F12, F13
P1VAS030D0123	J18	P1VAS090A0285	J20	P1VAS6/4447881D	J25	P5GN-022MSG003B	F11
P1VAS030D0240	J18	P1VAS090A0367	J20	P1VAS6/4447881F	J25	P5GN-022MSG005B	F11
P1VAS030D0460	J18	P1VAS090A0520	J20	P1VAS6/4447883*	J25	P5GN-022MSG006B	F11
P1VAS030D0E50	J18	P1VAS160	J13, J24	P1VAS6/4447883C	J25	P5GN-032	F12, F13
P1VAS060	J13, J24	P1VAS160 A*016	J15	P1VAS6/4447883D	J25	P5GN-032MSG005B	F11
P1VAS060 A*018	J15	P1VAS160 A*020	J15	P1VAS6/4447883F	J25	P5GN-032MSG006B	F11
P1VAS060 A*034	J15	P1VAS160 A*032	J15	P1VAS6/4447884*	J25	P5GN-032MSG010B	F11
P1VAS060 A*050	J15	P1VAS160 A*070	J15	P1VAS6/4447884C	J25	P5GP	F2, F23, F24
P1VAS060 A*070	J15	P1VAS160 A*120	J15	P1VAS6/4447884D	J25	P5GP-000ESX025B	F23
P1VAS060 A*200	J15	P1VAS160 A*250	J15	P1VAS6/4447884F	J25	P5GQ	F2, F25, F26
P1VAS060 A*300	J15	P1VAS160 A*960	J15	P1VAS6/4449191*	J25	P5GQ-000*010	F25
P1VAS060 A*400	J15	P1VAS160A*	J20, J23	P1VAS6/4449191E	J25	P5GQ-000*020	F25
P1VAS060 A*550	J15	P1VAS160A*016	J14, J23	P1VAS6/4449191F	J25	P5GQ-000QXS010B	F25
P1VAS060 A*D50	J15	P1VAS160A*020	J14, J23	P1VAS6/4455801*	J25	P5GQ-000QXS020B	F25
P1VAS060A*	J20, J21	P1VAS160A*032	J14, J23	P1VAS6/4455801D	J25	P5GQ-000RSX010B	F25
P1VAS060A*018	J14, J21	P1VAS160A*070	J14, J23	P1VAS6/4455801G	J25	P5GQ-000RSX020B	F25
P1VAS060A*034	J14, J21	P1VAS160A*120	J14, J23	P1VAS6/4455801H	J25	P5GR	F2, F5, F6, F7
P1VAS060A*050	J14, J21	P1VAS160A*250	J14, J23	P1VAS6/4455804*	J25	P5GR-010	F7
P1VAS060A*070	J14, J21	P1VAS160A*960	J14	P1VAS6/4455804B	J25	P5GR-010***006	F6, F7
P1VAS060A*200	J14, J21	P1VAS160A0016	J20	P1VAS6/4455804C	J25	P5GR-010***013	F6, F7
P1VAS060A*300	J14, J21	P1VAS160A0020	J20	P1V-S Series	J1	P5GR-010DSG006B	F5
P1VAS060A*400	J14, J21	P1VAS160A0032	J20	P1X	G90	P5GR-010DSG013B	F5
P1VAS060A*550	J14, J21	P1VAS160A0070	J20	P25	G85	P5GR-010MSG006B	F5
P1VAS060A*D50	J14	P1VAS160A0120	J20	P32, P40, P50	G85	P5GR-010MSG013B	F5
P1VAS060A0018	J20	P1VAS160A0250	J20	P5E	E2	P5GR-014	F7
P1VAS060A0034	J20	P1VAS6/1191563*	J25	P5E Series	E33	P5GR-014***016	F6, F7
P1VAS060A0050	J20	P1VAS6/1191563B	J25	P5G-011***006	F9	P5GR-014***025	F6, F7

Application Fax Forms  
Part Number Index  
Safety Guide  
Offer of Sale  
Application Fax Forms, Part Number Index, Safety Guide, Offer of Sale



For inventory, lead times, and kit lookup, visit [www.pdnplu.com](http://www.pdnplu.com)

Model No.	Section / Page No.	Model No.	Section / Page No.	Model No.	Section / Page No.	Model No.	Section / Page No.
P5GR-014DSG016B.....	F5	P5GU-013(019).....	F10	P5MD-014SSG016B.....	F31	P8SAGSCHX.....	L6
P5GR-014DSG025B.....	F5	P5GU-013(025).....	F10	P5MD-014TSG016B.....	F31	P8SAGSFAX.....	L6
P5GR-014MSG016B.....	F5	P5GU-013***019.....	F9	P5MD-020.....	F32	P8SAGSFDX.....	L6
P5GR-014MSG025B.....	F5	P5GU-013***025.....	F9	P5MD-020SSG025B.....	F31	P8SAGSFLX.....	L6
P5GR-021.....	F7	P5GU-013MFG019B.....	F8	P5MD-020TSG025B.....	F31	P8SAGSFTX.....	L6
P5GR-021***025.....	F6, F7	P5GU-013MFG025B.....	F8	P5MD-027.....	F32	P8S-AMA1.....	L12
P5GR-021***038.....	F6, F7	P5GU-013MFG019B.....	F8	P5MD-027SSG032B.....	F31	P8S-CABL-052.....	F26
P5GR-021DSG025B.....	F5	P5GU-013MSG019B.....	F8	P5MD-027TSG032B.....	F31	P8S-CABL-053.....	F26
P5GR-021DSG038B.....	F5	P5GV.....	F2, F3, F4	P5T.....	E2	P8S-TMA07.....	L10
P5GR-021MSG025B.....	F5	P5GV-010MFG003B.....	F3	P5T Series.....	E3	P8S-TMA08.....	L10
P5GR-021MSG038B.....	F5	P5GV-010MFG005B.....	F3	P63.....	G85	P8S-TMA09.....	L10
P5GS.....	F2, F17, F18, F19	P5GV-010MFG006B.....	F3	P63.....	G85	P8S-TMAOX.....	L10
P5GS-016M***19B.....	F18	P5GV-010MS.....	F4	P80.....	G85	P8S-TMC01.....	L10
P5GS-016M***32B.....	F18	P5GV-010MS(F)G003B.....	F4	P80.....	G85	P8S-TMC02.....	L10
P5GS-016MSG019B.....	F17, F19	P5GV-010MS(F)G005B.....	F4	P8CS0803J.....	L11	P8S-TMC03.....	L10
P5GS-016MSG032B.....	F17, F19	P5GV-010MS(F)G006B.....	F4	P8CS1204J.....	L11	PIC-4KMB.....	E42
P5GS-024M***25B.....	F18	P5GV-010MSG003B.....	F3	P8S-A34X.....	L12	PIC-4LMB.....	E42
P5GS-024M***51B.....	F18	P5GV-010MSG005B.....	F3	P8SAGACHA.....	B139, L9	PIC-4MMB.....	E42
P5GS-024MSG025B.....	F17, F19	P5GV-010MSG006B.....	F3	P8SAGACHB.....	B139, L9	PIC-4NMB.....	E42
P5GS-024MSG051B.....	F17, F19	P5GW.....	F2, F27, F28, F29, F30	P8SAGACHD.....	B139, L9	PIC-4PMB.....	E42
P5GS-032M***38B.....	F18	P5GW-032.....	F28, F29, F30	P8SAGACHF.....	B139, L9	PIC-4QMB.....	E42
P5GS-032M***74B.....	F18	P5GW-032DSG004B.....	F27	P8SAGACHH.....	B139, L9	PK032P1D01.....	B115
P5GS-032MSG038B.....	F17, F19	P5GW-032MFG004B.....	F27	P8SAGDFMXW.....	L6	PK032P1D05.....	B115
P5GS-032MSG074B.....	F17, F19	P5GW-032MSG004B.....	F27	P8SAGDFTXW.....	L6	PK040P1D01.....	B115
P5GT.....	F2, F20, F21, F22	P5GW-043.....	F28, F29, F30	P8SAGECNX.....	L6	PK040P1D05.....	B115
P5GT-025.....	F22	P5GW-043DSG006B.....	F27	P8SAGEFRX.....	L6	PK050P1D01.....	B115
P5GT-025(006).....	F21, F22	P5GW-043MFG006B.....	F27	P8SAGEFRX1.....	L6	PK050P1D05.....	B115
P5GT-025(010).....	F21, F22	P5GW-043MSG006B.....	F27	P8SAGHMHA.....	B139, L9	PK063P1D01.....	B115
P5GT-025MFG006B.....	F20	P5GW-055.....	F28, F29, F30	P8SAGHMHB.....	B139, L9	PK063P1D05.....	B115
P5GT-025MFG010B.....	F20	P5GW-055DSG008B.....	F27	P8SAGHMHD.....	B139, L9	PK080P1D01.....	B115
P5GT-025MSG006B.....	F20	P5GW-055MFG008B.....	F27	P8SAGHMHF.....	B139, L9	PK080P1D05.....	B115
P5GT-025MSG010B.....	F20	P5GW-055MSG008B.....	F27	P8SAGHMHH.....	B139, L9	PK100P1D01.....	B115
P5GT-032.....	F21, F22	P5GW-072.....	F28, F29, F30	P8SAGMCHX.....	L6	PK100P1D05.....	B115
P5GT-032MFG013B.....	F20	P5GW-072DSG010B.....	F27	P8SAGMFAX.....	L6	PK125P1D01.....	B115
P5GT-032MSG013B.....	F20	P5GW-072MFG010B.....	F27	P8SAGMFDX.....	L6	PK125P1D05.....	B115
P5GT-046.....	F21, F22	P5GW-072MSG010B.....	F27	P8SAGNCHX.....	L6	PK1504MA01.....	B83
P5GT-046MFG019B.....	F20	P5GW-095.....	F28, F29, F30	P8SAGNFAX.....	L6	PK1504MA05.....	B83
P5GT-046MSG019B.....	F20	P5GW-095DSG013B.....	F27	P8SAGNFDX.....	L6	PK1504ML01.....	B87
P5GT-064.....	F21, F22	P5GW-095MFG013B.....	F27	P8SAGPCHX.....	L6	PK1504ML05.....	B87
P5GT-064MFG032B.....	F20	P5GW-095MSG013B.....	F27	P8SAGPFAX.....	L6	PK2004MA01.....	B83
P5GT-064MSG032B.....	F20	P5GW-120.....	F28, F29, F30	P8SAGPFAXS.....	L6	PK2004MA05.....	B83
P5GT-089.....	F21, F22	P5GW-120DSG016B.....	F27	P8SAGPFDX.....	L6	PK2004ML01.....	B87
P5GT-089MFG051B.....	F20	P5GW-120MFG016B.....	F27	P8SAGPFLX.....	L6	PK2004ML05.....	B87
P5GT-089MSG051B.....	F20	P5GW-120MSG016B.....	F27	P8SAGPFTX.....	L6	PK2504MA01.....	B83
P5GU.....	F2, F8, F9, F10	P5GW-156.....	F28, F29, F30	P8SAGQCHX.....	L6	PK2504MA05.....	B83
P5GU-011.....	F10	P5GW-156DSG025B.....	F27	P8SAGQFAX.....	L6	PK2504ML01.....	B87
P5GU-011(006).....	F10	P5GW-156MFG025B.....	F27	P8SAGQFDX.....	L6	PK2504ML05.....	B87
P5GU-011(013).....	F10	P5GW-156MSG025B.....	F27	P8SAGQLX.....	L6	PK3254MA01.....	B83
P5GU-011***013.....	F9	P5GW-225.....	F28, F29, F30	P8SAGQLFLX.....	L6	PK3254MA05.....	B83
P5GU-011MFG006B.....	F8	P5GW-225DSG035B.....	F27	P8SAGRCHX.....	L6	PK3254ML01.....	B87
P5GU-011MFG013B.....	F8	P5GW-225MFG035B.....	F27	P8SAGRFX.....	L6	PK3254ML05.....	B87
P5GU-011MSG006B.....	F8	P5GW-225MSG035B.....	F27	P8SAGRFDX2.....	L6	PK4004MA01.....	B83
P5GU-011MSG013B.....	F8	P5MD.....	F31, F32	P8SAGRFLX1.....	L6	PK4004MA05.....	B83
P5GU-013.....	F10	P5MD-014.....	F32	P8SAGRFLX2.....	L6	PK4004ML01.....	B87
				P8SAGRFTX1.....	L6		

Application  
Fax Forms

Part Number  
Index

Safety  
Guide

Offer of  
Sale

Application Fax Forms,  
Part Number Index, Safety  
Guide, Offer of Sale

**N**



For inventory, lead times, and kit lookup, visit [www.pdnplu.com](http://www.pdnplu.com)



Model No.	Section / Page No.	Model No.	Section / Page No.	Model No.	Section / Page No.	Model No.	Section / Page No.
PK4004ML05.....	B87	PRNA10-P.....	H18	PSK-P5T20.....	E13	RG04MAM061.....	B82
PK5004MA01.....	B83	PRNA10S.....	H12, H13	PSK-P5T25.....	E13	RG04MAM065.....	B82
PK5004MA05.....	B83	PRNA10S/D.....	H12, H15	PSK-P5T32.....	E13	RG04MAM101.....	B82
PK5004ML01.....	B87	PRNA1D.....	H13	PSK-P5T40.....	E13	RG04MAM105.....	B82
PK5004ML05.....	B87	PRNA1-L.....	H18	PSK-P5T50.....	E13	RG04MAM131.....	B82
PK6004MA01.....	B83	PRNA1-P.....	H18	PSK-P5T63.....	E13	RG04MAM135.....	B82
PK6004MA05.....	B83	PRNA1S.....	H13, H15	PSK-P5T80.....	E13	RG04MAM171.....	B82
PK6004ML01.....	B87	PRNA1S/D.....	H12	PTR Series.....	H23, H24	RG04MAM175.....	B82
PK6004ML05.....	B87	PRNA20.....	H21	PTR101.....	H26	RG04ML0061.....	B86
PK8004MA01.....	B83	PRNA20D.....	H13	PTR102.....	H26	RG04ML0065.....	B86
PK8004MA05.....	B83	PRNA20-L.....	H18	PTR151.....	H26	RG04ML0101.....	B86
PK8004ML01.....	B87	PRNA20-P.....	H18	PTR152.....	H26	RG04ML0105.....	B86
PK8004ML05.....	B87	PRNA20S.....	H12, H13	PTR201.....	H26	RG04ML0131.....	B86
PL16.....	G52, G54	PRNA20S/D.....	H12, H16	PTR202.....	H26	RG04ML0135.....	B86
PL25.....	G52, G54	PRNA3.....	H21	PTR251.....	H26	RG04ML0171.....	B86
PL32.....	G52, G54	PRNA3D.....	H13	PTR252.....	H26	RG04ML0175.....	B86
PL40.....	G52, G54	PRNA3-L.....	H18	PTR321.....	H26	RG04MLH061.....	B86
PL50.....	G52, G54	PRNA3-P.....	H18	PTR322.....	H26	RG04MLH065.....	B86
PRL.....	K6	PRNA3S.....	H12, H13	PUR IP67.....	L6	RG04MLH101.....	B86
PRN Series.....	H11, H12	PRNA3S/D.....	H12, H15	PV Series.....	H3	RG04MLH105.....	B86
PRN150.....	H12, H17, H22	PS 16/25.....	G48, G50	PV10 & 11.....	H5	RG04MLH131.....	B86
PRN150D.....	H14	PS 25/25.....	G48, G50	PV22D.....	H5	RG04MLH135.....	B86
PRN150-L.....	H19	PS 25/35.....	G48, G50	PV44 & 46.....	H5	RG04MLH171.....	B86
PRN150-P.....	H19	PS 25/44.....	G48, G50	PVC IP67.....	L6	RG04MLH175.....	B86
PRN150S.....	H14	PS 32/35.....	G48, G50	PWBA3412.....	K5	RG04MLM061.....	B86
PRN150S/D.....	H14	PS 32/44.....	G48, G50	PWBA3468.....	K5	RG04MLM065.....	B86
PRN1AS.....	H12	PS 40/44.....	G48, G50	PWBA3469.....	K5	RG04MLM101.....	B86
PRN30.....	H21	PS 40/60.....	G48, G50	PWBA3493.....	K5	RG04MLM105.....	B86
PRN300.....	H12, H17, H22	PS 50/60.....	G48	PWBA3822.....	K5	RG04MLM131.....	B86
PRN300D.....	H14	PS 50/76.....	G48, G50	PWBA38227.....	K5	RG04MLM135.....	B86
PRN300-L.....	H19	PS2028BP.....	B70	PWBA3833.....	K5	RG04MLM171.....	B86
PRN300S.....	H14	PS2028JCP.....	B70	PWBA38337.....	K5	RG04MLM175.....	B86
PRN300S/D.....	H14	PS203279BP.....	B70	PWBA3888.....	K5	RG0P1D0121.....	B115
PRN30D.....	H13, H14	PS203283BP.....	B70	PWBA38887.....	K5	RG0P1D0125.....	B115
PRN30-L.....	H18	PS2032J79CP.....	B70	PWBA3899.....	K5	RG0P1D0161.....	B115
PRN30-P.....	H18	PS2032J83CP.....	B70	PWBA38997.....	K5	RG0P1D0165.....	B115
PRN30S.....	H13, H14	PS2429BP.....	B70			RG0P1D0201.....	B115
PRN30S/D.....	H12, H16	PS2429JBP.....	B70			RG0P1D0205.....	B115
PRN50.....	H12, H17, H22	PS243079BP.....	B70			RG0P1D0251.....	B115
PRN50D.....	H14	PS243083BP.....	B70			RG0P1D0255.....	B115
PRN50-L.....	H19	PS2430J79BP.....	B70			RG0P1D0321.....	B115
PRN50-P.....	H19	PS2430J83BP.....	B70			RG0P1D0325.....	B115
PRN50S.....	H14	PS2893C##P.....	B70			RK0P1D0121.....	B115
PRN50S/D.....	H14	PS2893CP.....	B70			RK0P1D0125.....	B115
PRN800.....	H12, H17, H22	PS2893D83P.....	B70			RK0P1D0161.....	B115
PRN800D.....	H14	PS2893DP.....	B70			RK0P1D0165.....	B115
PRN800-L.....	H19	PS2932BP.....	B70			RK0P1D0201.....	B115
PRN800S.....	H14	PS2932JBP.....	B70			RK0P1D0205.....	B115
PRN800S/D.....	H14	PS294679BP.....	B70			RK0P1D0251.....	B115
PRNA Series.....	H11, H12	PS294683BP.....	B70			RK0P1D0255.....	B115
PRNA1.....	H21	PS2946J79BP.....	B70			RK0P1D0321.....	B115
PRNA10.....	H21	PS2946J83BP.....	B70			RK0P1D0325.....	B115
PRNA10D.....	H13	PSK-P5T100.....	E13				
PRNA10-L.....	H18	PSK-P5T16.....	E13				

**R**

**S**

Application Fax Forms  
 Part Number Index  
 Safety Guide  
 Offer of Sale  
 Application Fax Forms, Part Number Index, Safety Guide, Offer of Sale



For inventory, lead times, and kit lookup, visit [www.pdnplu.com](http://www.pdnplu.com)

Model No.	Section / Page No.	Model No.	Section / Page No.	Model No.	Section / Page No.	Model No.	Section / Page No.
SC 190.....M20, M21, M44, M45		SK32304ML1 .....	B89	SL50 .....	G43		
SC 190M.....M21, M44, M45		SK32304ML5 .....	B89	SL63 .....	G43, G45		
SC 190M-880* .....	M47	SK40104MA1 .....	B85	SL80 .....	G43, G45		
SC 300.....M20, M21, M22, M23 M44, M45		SK40104MA5 .....	B85	SR Series .....	C2		
SC 300M.....M21, M23, M44, M45		SK40104ML1 .....	B89	SRD Series.....	C2		
SC 300M-880* .....	M47	SK40104ML5 .....	B89	SRDM Series.....	C2		
SC 300M-9 .....	M23	SK40304MA1 .....	B85	SRG .....	C34		
SC 650.....M20, M21, M22, M23 M44, M45		SK40304MA5 .....	B85	SRGM .....	C34		
SC 650M.....M21, M23, M44, M45		SK40304ML1 .....	B89	SRM Series .....	C2		
SC 650M-880* .....	M47	SK40304ML5 .....	B89	SRX.....	C38		
SC 650M-9 .....	M23	SK50104MA1 .....	B85	STL/KF16.....	G80, G82		
SC 925.....M20, M21, M44, M45		SK50104MA5 .....	B85	STL/KF25.....	G80, G82		
SC 925M.....M21, M44, M45		SK50104ML1 .....	B89	STL/KF32.....	G80, G82		
SG2MNR1501.....	B153	SK50104ML5 .....	B89	STL/KF40.....	G80, G82		
SG2MNR1505.....	B153	SK50304MA1 .....	B85	STL/KF50.....	G80, G82		
SG2MNR2001.....	B153	SK50304MA5 .....	B85	STL16 .....	G57, G59		
SG2MNR2501.....	B153	SK50304ML1 .....	B89	STL25 .....	G57, G59		
SG2MNR2505.....	B153	SK50304ML5 .....	B89	STL32 .....	G57, G59		
SG2MNR3201.....	B153	SK60104MA1 .....	B85	STL40 .....	G57, G59		
SG2MNR3205.....	B153	SK60104MA5 .....	B85	STL50 .....	G57, G59		
SG2MNR4001.....	B153	SK60104ML1 .....	B89				
SG2MNR4005.....	B153	SK60104ML5 .....	B89				
SK15104MA1.....	B85	SK60304MA1 .....	B85				
SK15104MA5.....	B85	SK60304MA5 .....	B85				
SK15104ML1 .....	B89	SK60304ML1 .....	B89				
SK15104ML5 .....	B89	SK60304ML5 .....	B89				
SK15304MA1.....	B85	SK80104MA1 .....	B85				
SK15304MA5.....	B85	SK80104MA5 .....	B85				
SK15304ML1 .....	B89	SK80104ML1 .....	B89				
SK15304ML5 .....	B89	SK80104ML5 .....	B89				
SK20104MA1.....	B85	SK80304MA1 .....	B85				
SK20104MA5.....	B85	SK80304MA5 .....	B85				
SK20104ML1 .....	B89	SK80304ML1 .....	B89				
SK20104ML5 .....	B89	SK80304ML5 .....	B89				
SK20304MA1.....	B85	SKS05LP251 .....	D5, D10				
SK20304MA5.....	B85	SKS05LP255 .....	D5, D10				
SK20304ML1 .....	B89	SKS07LP311 .....	D5, D10				
SK20304ML5 .....	B89	SKS07LP315 .....	D5, D10				
SK25104MA1.....	B85	SKS12LP501 .....	D5, D10				
SK25104MA5.....	B85	SKS12LP505 .....	D5, D10				
SK25104ML1 .....	B89	SKS15LP621 .....	D5, D10				
SK25104ML5 .....	B89	SKS15LP625 .....	D5, D10				
SK25304MA1.....	B85	SKS20LP751 .....	D5, D10				
SK25304MA5.....	B85	SKS20LP755 .....	D5, D10				
SK25304ML1 .....	B89	SKS25LP751 .....	D5, D10				
SK25304ML5 .....	B89	SKS25LP755 .....	D5, D10				
SK32104MA1.....	B85	SKS30LP871 .....	D5, D10				
SK32104MA5.....	B85	SKS30LP875 .....	D5, D10				
SK32104ML1 .....	B89	SKS40LP101 .....	D5, D10				
SK32104ML5 .....	B89	SKS40LP105 .....	D5, D10				
SK32304MA1.....	B85	SL16 .....	G43, G45				
SK32304MA5.....	B85	SL25 .....	G43, G45				
		SL32 .....	G43, G45				
		SL40 .....	G43, G45				

**W**

W68GC-2-1 .....	K3
W68GC-2-2 .....	K3
W68GC-2-4 .....	K3
W68GC-3-2 .....	K3
W68GC-3-4 .....	K3
W68GC-4-1 .....	K3
W68GC-4-2 .....	K3
W68GC-4-4 .....	K3
W68GC-4-6 .....	K3
W68GC-5/32-1 .....	K3
W68GC-5/32-2 .....	K3
W68GC-5/32-4 .....	K3

**Z**

ZSM25 .....	G75
ZSM25HD .....	G76

Application Fax Forms
Part Number Index
Safety Guide
Offer of Sale
Application Fax Forms, Part Number Index, Safety Guide, Offer of Sale
<b>N</b>



For inventory, lead times, and kit lookup, visit [www.pdnplu.com](http://www.pdnplu.com)



**Safety Guide for Selecting and Using Hydraulic, Pneumatic Cylinders and Their Accessories**

**WARNING: ⚠ FAILURE OF THE CYLINDER, ITS PARTS, ITS MOUNTING, ITS CONNECTIONS TO OTHER OBJECTS, OR ITS CONTROLS CAN RESULT IN:**

- Unanticipated or uncontrolled movement of the cylinder or objects connected to it.
- Falling of the cylinder or objects held up by it.
- Fluid escaping from the cylinder, potentially at high velocity.

**THESE EVENTS COULD CAUSE DEATH OR PERSONAL INJURY BY, FOR EXAMPLE, PERSONS FALLING FROM HIGH LOCATIONS, BEING CRUSHED OR STRUCK BY HEAVY OR FAST MOVING OBJECTS, BEING PUSHED INTO DANGEROUS EQUIPMENT OR SITUATIONS, OR SLIPPING ON ESCAPED FLUID.**

Before selecting or using Parker (The Company) cylinders or related accessories, it is important that you read, understand and follow the following safety information. Training is advised before selecting and using The Company's products.

**1.0 General Instructions**

**1.1 Scope** – This safety guide provides instructions for selecting and using (including assembling, installing, and maintaining) cylinder products. This safety guide is a supplement to and is to be used with the specific Company publications for the specific cylinder products that are being considered for use.

**1.2 Fail Safe** – Cylinder products can and do fail without warning for many reasons. All systems and equipment should be designed in a fail-safe mode so that if the failure of a cylinder product occurs people and property won't be endangered.

**1.3 Distribution** – Provide a free copy of this safety guide to each person responsible for selecting or using cylinder products. Do not select or use The Company's cylinders without thoroughly reading and understanding this safety guide as well as the specific Company publications for the products considered or selected.

**1.4 User Responsibility** – Due to very wide variety of cylinder applications and cylinder operating conditions, The Company does not warrant that any particular cylinder is suitable for any specific application. This safety guide does not analyze all technical parameters that must be considered in selecting a product. The hydraulic and pneumatic cylinders outlined in this catalog are designed to The Company's design guidelines and do not necessarily meet the design guideline of other agencies such as American Bureau of Shipping, ASME Pressure Vessel Code etc. The user, through its own analysis and testing, is solely responsible for:

- Making the final selection of the cylinders and related accessories.
- Determining if the cylinders are required to meet specific design requirements as required by the Agency(s) or industry standards covering the design of the user's equipment.
- Assuring that the user's requirements are met, OSHA requirements are met, and safety guidelines from the applicable agencies such as but not limited to ANSI are followed and that the use presents no health or safety hazards.
- Providing all appropriate health and safety warnings on the equipment on which the cylinders are used.

**1.5 Additional Questions** – Call the appropriate Company technical service department if you have any questions or require any additional information. See the Company publication for the product being considered or used, or call 1-800-CPARKER, or go to [www.parker.com](http://www.parker.com), for telephone numbers of the appropriate technical service department.

**2.0 Cylinder and Accessories Selection**

**2.1 Seals** – Part of the process of selecting a cylinder is the selection of seal compounds. Before making this selection, consult the "seal information page(s)" of the publication for the series of cylinders of interest.

The application of cylinders may allow fluids such as cutting fluids, wash down fluids etc. to come in contact with the external area of the cylinder. These fluids may attack the piston rod wiper and or the primary seal and must be taken into account when selecting and specifying seal compounds.

Dynamic seals will wear. The rate of wear will depend on many operating factors. Wear can be rapid if a cylinder is mis-aligned or if the cylinder has been improperly serviced. The user must take seal wear into consideration in the application of cylinders.

**2.2 Piston Rods** – Possible consequences of piston rod failure or separation of the piston rod from the piston include, but are not limited to are:

- Piston rod and or attached load thrown off at high speed.
- High velocity fluid discharge.
- Piston rod extending when pressure is applied in the piston retract mode.

Piston rods or machine members attached to the piston rod may move suddenly and without warning as a consequence of other conditions occurring to the machine such as, but not limited to:

- Unexpected detachment of the machine member from the piston rod.
- Failure of the pressurized fluid delivery system (hoses, fittings, valves, pumps, compressors) which maintain cylinder position.
- Catastrophic cylinder seal failure leading to sudden loss of pressurized fluid.
- Failure of the machine control system.

Follow the recommendations of the "Piston Rod Selection Chart and Data" in the publication for the series of cylinders of interest. The suggested piston rod diameter in these charts must be followed in order to avoid piston rod buckling.

Piston rods are not normally designed to absorb bending moments or loads which are perpendicular to the axis of piston rod motion. These additional loads can cause the piston rod to fail. If these types of additional loads are expected to be imposed on the piston rod, their magnitude should be made known to our engineering department.

The cylinder user should always make sure that the piston rod is securely attached to the machine member.

On occasion cylinders are ordered with double rods (a piston rod extended from both ends of the cylinder). In some cases a stop is threaded on to one of the piston rods and used as an external stroke adjuster. On occasions spacers are attached to the machine member connected to the piston rod and also used as a stroke adjuster. In both cases the stops will create a pinch point and the user should consider appropriate use of guards. If these external stops are not perpendicular to the mating contact surface, or if debris is trapped between the contact surfaces, a bending moment will be placed on the piston rod, which can lead to piston rod failure. An external stop will also negate the effect of cushioning and will subject the piston rod to impact loading. Those two (2) conditions can cause piston rod failure. Internal stroke adjusters are available with and without cushions. The use of external stroke adjusters should be reviewed with our engineering department.

The piston rod to piston and the stud to piston rod threaded connections are secured with an anaerobic adhesive. The strength of the adhesive decreases with increasing temperature. Cylinders which can be exposed to temperatures above +250°F (+121°C) are to be ordered with a non studded piston rod and a pinned piston rod joint.

**2.3 Cushions** – Cushions should be considered for cylinder applications when the piston velocity is expected to be over 4 inches/second.

Cylinder cushions are normally designed to absorb the energy of a linear applied load. A rotating mass has considerably more energy than the same mass moving in a linear mode. Cushioning for a rotating mass application should be review by our engineering department.

**2.4 Cylinder Mountings** – Some cylinder mounting configurations may have certain limitations such as but not limited to minimum stroke for side or foot mounting cylinders or pressure de-ratings for certain mounts. Carefully review the catalog for these types of restrictions.

Always mount cylinders using the largest possible high tensile alloy steel socket head cap screws that can fit in the cylinder mounting holes and torque them to the manufacturer's recommendations for their size.

**2.5 Port Fittings** – Hydraulic cylinders applied with meter out or deceleration circuits are subject to intensified pressure at piston rod end. The rod end pressure is approximately equal to:

$$\frac{\text{operating pressure} \times \text{effective cap end area}}{\text{effective rod end piston area}}$$

Contact your connector supplier for the pressure rating of individual connectors.

**3.0 Cylinder and Accessories Installation and Mounting**

**3.1 Installation**

**3.1.1** – Cleanliness is an important consideration, and cylinders are shipped with the ports plugged to protect them from contaminants entering the ports. These plugs should not be removed until the piping is to be installed. Before making the connection to the cylinder ports, piping should be thoroughly cleaned to remove all chips or burrs which might have resulted from threading or flaring operations.

Application Fax Forms	Part Number Index	Safety Guide	Offer of Sale	Application Fax Forms, Part Number Index, Safety Guide, Offer of Sale
-----------------------	-------------------	--------------	---------------	---



For inventory, lead times, and kit lookup, visit [www.pdnplu.com](http://www.pdnplu.com)

**3.1.2** – Cylinders operating in an environment where air drying materials are present such as fast-drying chemicals, paint, or weld splatter, or other hazardous conditions such as excessive heat, should have shields installed to prevent damage to the piston rod and piston rod seals.

**3.1.3** – Proper alignment of the cylinder piston rod and its mating component on the machine should be checked in both the extended and retracted positions. Improper alignment will result in excessive rod gland and/or cylinder bore wear. On fixed mounting cylinders attaching the piston rod while the rod is retracted will help in achieving proper alignment.

**3.1.4** – Sometimes it may be necessary to rotate the piston rod in order to thread the piston rod into the machine member. This operation must always be done with zero pressure being applied to either side of the piston. Failure to follow this procedure may result in loosening the piston to rod-threaded connection. In some rare cases the turning of the piston rod may rotate a threaded piston rod gland and loosen it from the cylinder head. Confirm that this condition is not occurring. If it does, re-tighten the piston rod gland firmly against the cylinder head.

For double rod cylinders it is also important that when attaching or detaching the piston rod from the machine member that the torque be applied to the piston rod end of the cylinder that is directly attaching to the machine member with the opposite end unrestrained. If the design of the machine is such that only the rod end of the cylinder opposite to where the rod attaches to the machine member can be rotated, consult the factory for further instructions.

**3.2 Mounting Recommendations**

**3.2.1** – Always mount cylinders using the largest possible high tensile alloy steel socket head screws that can fit in the cylinder mounting holes and torque them to the manufacturer’s recommendations for their size.

**3.2.2** – Side-Mounted Cylinders – In addition to the mounting bolts, cylinders of this type should be equipped with thrust keys or dowel pins located so as to resist the major load.

**3.2.3** – Tie Rod Mounting – Cylinders with tie rod mountings are recommended for applications where mounting space is limited. The standard tie rod extension is shown as BB in dimension tables. Longer or shorter extensions can be supplied. Nuts used for this mounting style should be torqued to the same value as the tie rods for that bore size.

**3.2.4** – Flange Mount Cylinders – The controlled diameter of the rod gland extension on head end flange mount cylinders can be used as a pilot to locate the cylinders in relation to the machine. After alignment has been obtained, the flanges may be drilled for pins or dowels to prevent shifting.

**3.2.5** – Trunnion Mountings – Cylinders require lubricated bearing blocks with minimum bearing clearances. Bearing blocks should be carefully aligned and rigidly mounted so the trunnions will not be subjected to bending moments. The rod end should also be pivoted with the pivot pin in line and parallel to axis of the trunnion pins.

**3.2.6** – Clevis Mountings – Cylinders should be pivoted at both ends with centerline of pins parallel to each other. After cylinder is mounted, be sure to check to assure that the cylinder is free to swing through its working arc without interference from other machine parts.

**4.0 Cylinder and Accessories Maintenance, Troubleshooting and Replacement**

**4.1 Storage** – At times cylinders are delivered before a customer is ready to install them and must be stored for a period of time. When storage is required the following procedures are recommended.

**4.1.1** – Store the cylinders in an indoor area which has a dry, clean and noncorrosive atmosphere. Take care to protect the cylinder from both internal corrosion and external damage.

**4.1.2** – Whenever possible cylinders should be stored in a vertical position (piston rod up). This will minimize corrosion due to possible condensation which could occur inside the cylinder. This will also minimize seal damage.

**4.1.3** – Port protector plugs should be left in the cylinder until the time of installation.

**4.1.4** – If a cylinder is stored full of hydraulic fluid, expansion of the fluid due to temperature changes must be considered. Installing a check valve with free flow out of the cylinder is one method.

**4.1.5** – When cylinders are mounted on equipment that is stored outside for extended periods, exposed unpainted surfaces, e.g. piston rod, must be coated with a rust-inhibiting compound to prevent corrosion.

**4.2 Cylinder Trouble Shooting**

**4.2.1 – External Leakage**

**4.2.1.1** – Rod seal leakage can generally be traced to worn or damaged seals. Examine the piston rod for dents, gouges or score marks, and replace piston rod if surface is rough.

Rod seal leakage could also be traced to gland wear. If clearance is excessive, replace rod bushing and seal. Rod seal leakage can also be traced to seal deterioration. If seals are soft or gummy or brittle, check compatibility of seal material with lubricant used if air cylinder, or operating fluid if hydraulic cylinder. Replace with seal material, which is compatible with these fluids. If the seals are hard or have lost elasticity, it is usually due to exposure to temperatures in excess of 165°F. (+74°C). Shield the cylinder from the heat source to limit temperature to 350°F. (+177°C.) and replace with fluorocarbon seals.

**4.2.1.2** – Cylinder body seal leak can generally be traced to loose tie rods. Torque the tie rods to manufacturer’s recommendation for that bore size.

Excessive pressure can also result in cylinder body seal leak. Determine maximum pressure to rated limits. Replace seals and retorque tie rods as in paragraph above. Excessive pressure can also result in cylinder body seal leak. Determine if the pressure rating of the cylinder has been exceeded. If so, bring the operating pressure down to the rating of the cylinder and have the tie rods replaced.

Pinched or extruded cylinder body seal will also result in a leak. Replace cylinder body seal and retorque as in paragraph above.

Cylinder body seal leakage due to loss of radial squeeze which shows up in the form of flat spots or due to wear on the O.D. or I.D. – Either of these are symptoms of normal wear due to high cycle rate or length of service. Replace seals as per paragraph above.

**4.2.2 – Internal Leakage**

**4.2.2.1** – Piston seal leak (by-pass) 1 to 3 cubic inches per minute leakage is considered normal for piston ring construction. Virtually no static leak with lipseal type seals on piston should be expected. Piston seal wear is a usual cause of piston seal leakage. Replace seals as required.

**4.2.2.2** – With lipseal type piston seals excessive back pressure due to over-adjustment of speed control valves could be a direct cause of rapid seal wear. Contamination in a hydraulic system can result in a scored cylinder bore, resulting in rapid seal wear. In either case, replace piston seals as required.

**4.2.2.3** – What appears to be piston seal leak, evidenced by the fact that the cylinder drifts, is not always traceable to the piston. To make sure, it is suggested that one side of the cylinder piston be pressurized and the fluid line at the opposite port be disconnected. Observe leakage. If none is evident, seek the cause of cylinder drift in other component parts in the circuit.

**4.2.3 – Cylinder Fails to Move the Load**

**4.2.3.1** – Pneumatic or hydraulic pressure is too low. Check the pressure at the cylinder to make sure it is to circuit requirements.

**4.2.3.2** – Piston Seal Leak – Operate the valve to cycle the cylinder and observe fluid flow at valve exhaust ports at end of cylinder stroke. Replace piston seals if flow is excessive.

**4.2.3.3** – Cylinder is undersized for the load – Replace cylinder with one of a larger bore size.

**4.3 Erratic or Chatter Operation**

**4.3.1** – Excessive friction at rod gland or piston bearing due to load misalignment – Correct cylinder-to-load alignment.

**4.3.2** – Cylinder sized too close to load requirements – Reduce load or install larger cylinder.

**4.3.3** – Erratic operation could be traced to the difference between static and kinetic friction. Install speed control valves to provide a back pressure to control the stroke.

**4.4 Cylinder Modifications, Repairs, or Failed Component** – Cylinders as shipped from the factory are not to be disassembled and or modified. If cylinders require modifications, these modifications must be done at company locations or by The Company’s certified facilities. The Cylinder Division Engineering Department must be notified in the event of a mechanical fracture or permanent deformation of any cylinder component (excluding seals). This includes a broken piston rod, tie rod, mounting accessory or any other cylinder component. The notification should include all operation and application details. This information will be used to provide an engineered repair that will prevent recurrence of the failure.

It is allowed to disassemble cylinders for the purpose of replacing seals or seal assemblies. However, this work must be done by strictly following all the instructions provided with the seal kits.

Application Fax Forms
Part Number Index
Safety Guide
Offer of Sale
Application Fax Forms, Part Number Index, Safety Guide, Offer of Sale



For inventory, lead times, and kit lookup, visit [www.pdnplu.com](http://www.pdnplu.com)

**PARKER-HANNIFIN CORPORATION**  
**OFFER OF SALE**

**1. Definitions.** As used herein, the following terms have the meanings indicated.

- Buyer: means any customer receiving a Quote for Products.
- Goods: means any tangible part, system or component to be supplied by Seller.
- Products: means the Goods, Services and/or Software as described in a Quote.
- Quote: means the offer or proposal made by Seller to Buyer for the supply of Products.
- Seller: means Parker-Hannifin Corporation, including all divisions and businesses thereof.
- Services: means any services to be provided by Seller.
- Software: means any software related to the Goods, whether embedded or separately downloaded.
- Terms: means the terms and conditions of this Offer of Sale.

**2. Terms.** All sales of Products by Seller are expressly conditioned upon, and will be governed by the acceptance of, these Terms. These Terms are incorporated into any Quote provided by Seller to Buyer. Buyer's order for any Products whether communicated to Seller verbally, in writing, by electronic data interface or other electronic commerce, shall constitute acceptance of these Terms. Seller objects to any contrary or additional terms or conditions of Buyer. Reference in Seller's order acknowledgement to Buyer's purchase order or purchase order number shall in no way constitute an acceptance of any of Buyer's terms or conditions of purchase. No modification to these Terms will be binding on Seller unless agreed to in writing and signed by an authorized representative of Seller.

**3. Price; Payment.** The Products set forth in the Quote are offered for sale at the prices indicated in the Quote. Unless otherwise specifically stated in the Quote, prices are valid for thirty (30) days and do not include any sales, use, or other taxes or duties. Seller reserves the right to modify prices at any time to adjust for any raw material price fluctuations. Unless otherwise specified by Seller, all prices are F.C.A. Seller's facility (INCOTERMS 2020). All sales are contingent upon credit approval and full payment for all purchases is due thirty (30) days from the date of invoice (or such date as may be specified in the Quote). Unpaid invoices beyond the specified payment date incur interest at the rate of 1.5% per month or the maximum allowable rate under applicable law.

**4. Shipment; Delivery; Title and Risk of Loss.** All delivery dates are approximate, and Seller is not responsible for damages resulting from any delay. Regardless of the manner of shipment, delivery occurs and title and risk of loss or damage pass to Buyer, upon placement of the Products with the carrier at Seller's facility. Unless otherwise agreed prior to shipment and for domestic delivery locations only, Seller will select and arrange, at Buyer's sole expense, the carrier and means of delivery. When Seller selects and

arranges the carrier and means of delivery, freight and insurance costs for shipment to the designated delivery location will be prepaid by Seller and added as a separate line item to the invoice. Buyer shall be responsible for any additional shipping charges incurred by Seller due to Buyer's acts or omissions. Buyer shall not return or repackage any Products without the prior written authorization from Seller, and any return shall be at the sole cost and expense of Buyer.

**5. Warranty.** The warranty for the Products is as follows: (i) Goods are warranted against defects in material or workmanship for a period of twelve (12) months from the date of delivery or 2,000 hours of use, whichever occurs first; (ii) Services shall be performed in accordance with generally accepted practices and using the degree of care and skill that is ordinarily exercised and customary in the field to which the Services pertain and are warranted for a period of six (6) months from the date of completion of the Services; and (iii) Software is only warranted to perform in accordance with applicable specifications provided by Seller to Buyer for ninety (90) days from the date of delivery or, when downloaded by a Buyer or end-user, from the date of the initial download. All prices are based upon the exclusive limited warranty stated above, and upon the following disclaimer: **EXEMPTION CLAUSE; DISCLAIMER OF WARRANTY, CONDITIONS, REPRESENTATIONS: THIS WARRANTY IS THE SOLE AND ENTIRE WARRANTY, CONDITION, AND REPRESENTATION, PERTAINING TO PRODUCTS. SELLER DISCLAIMS ALL OTHER WARRANTIES, CONDITIONS, AND REPRESENTATIONS, WHETHER STATUTORY, EXPRESS OR IMPLIED, INCLUDING BUT NOT LIMITED TO THOSE RELATING TO DESIGN, NONINFRINGEMENT, MERCHANTABILITY, AND FITNESS FOR A PARTICULAR PURPOSE. SELLER DOES NOT WARRANT THAT THE SOFTWARE IS ERROR-FREE OR FAULT-TOLERANT, OR THAT BUYER'S USE THEREOF WILL BE SECURE OR UNINTERRUPTED. UNLESS OTHERWISE AUTHORIZED IN WRITING BY SELLER, THE SOFTWARE SHALL NOT BE USED IN CONNECTION WITH HAZARDOUS OR HIGH RISK ACTIVITIES OR ENVIRONMENTS. EXCEPT AS EXPRESSLY STATED HEREIN, ALL PRODUCTS ARE PROVIDED "AS IS".**

**6. Claims; Commencement of Actions.** Buyer shall promptly inspect all Products upon receipt. No claims for shortages will be allowed unless reported to Seller within ten (10) days of delivery. Buyer shall notify Seller of any alleged breach of warranty within thirty (30) days after the date the non-conformance is or should have been discovered by Buyer. Any claim or action against Seller based upon breach of contract or any other theory, including tort, negligence, or otherwise must be commenced within twelve (12) months from the date of the alleged breach or other alleged event, without regard to the date of discovery.

**7. LIMITATION OF LIABILITY.** IN THE EVENT OF A BREACH OF WARRANTY, SELLER WILL, AT ITS OPTION, REPAIR OR REPLACE THE NON-CONFORMING PRODUCT, RE-PERFORM THE SERVICES, OR REFUND THE PURCHASE PRICE PAID WITHIN A REASONABLE PERIOD OF TIME. **IN NO EVENT IS SELLER LIABLE FOR**

08/20

Application Fax Forms  
Part Number Index  
Safety Guide  
Offer of Sale  
Application Fax Forms, Part Number Index, Safety Guide, Offer of Sale  
**N**



For inventory, lead times, and kit lookup, visit [www.pdnplu.com](http://www.pdnplu.com)

N18

Parker Hannifin Corporation  
Pneumatic Division  
Wadsworth, Ohio  
[www.parker.com/pneumatics](http://www.parker.com/pneumatics)



**ANY SPECIAL, INDIRECT, INCIDENTAL OR CONSEQUENTIAL DAMAGES INCLUDING ANY LOSS OF REVENUE OR PROFITS, WHETHER BASED IN CONTRACT, TORT OR OTHER LEGAL THEORY. IN NO EVENT SHALL SELLER'S LIABILITY UNDER ANY CLAIM MADE BY BUYER EXCEED THE PURCHASE PRICE PAID FOR THE PRODUCTS.**

**8. Confidential Information.** Buyer acknowledges and agrees that any technical, commercial, or other confidential information of Seller, including, without limitation, pricing, technical drawings or prints and/or part lists, which has been or will be disclosed, delivered or made available, whether directly or indirectly, to Buyer ("Confidential Information"), has been and will be received in confidence and will remain the property of Seller. Buyer further agrees that it will not use Seller's Confidential Information for any purpose other than for the benefit of Seller.

**9. Loss to Buyer's Property.** Any tools, patterns, materials, equipment or information furnished by Buyer or which are or become Buyer's property ("Buyer's Property"), will be considered obsolete and may be destroyed by Seller after two (2) consecutive years have elapsed without Buyer ordering the Products manufactured using Buyer's Property. Furthermore, Seller shall not be responsible for any loss or damage to Buyer's Property while it is in Seller's possession or control.

**10. Special Tooling.** "Special Tooling" includes but is not limited to tools, jigs, fixtures and associated manufacturing equipment acquired or necessary to manufacture Goods. Seller may impose a tooling charge for any Special Tooling. Such Special Tooling shall be and remain Seller's property notwithstanding payment of any charges by Buyer. In no event will Buyer acquire any interest in the Special Tooling, even if such Special Tooling has been specially converted or adapted for manufacture of Goods for Buyer and notwithstanding any charges paid by Buyer. Unless otherwise agreed, Seller has the right to alter, discard or otherwise dispose of any Special Tooling or other property owned by Seller in its sole discretion at any time.

**11. Security Interest.** To secure payment of all sums due from Buyer, Seller retains a security interest in all Products delivered to Buyer and, Buyer's acceptance of these Terms is deemed to be a Security Agreement under the Uniform Commercial Code. Buyer authorizes Seller as its attorney to execute and file on Buyer's behalf all documents Seller deems necessary to perfect Seller's security interest.

**12. User Responsibility.** Buyer, through its own analysis and testing, is solely responsible for making the final selection of the Products and assuring that all performance, endurance, maintenance, safety and warning requirements of the application of the Products are met. Buyer must analyze all aspects of the application and follow applicable industry standards, specifications, and any technical information provided with the Quote or the Products, such as Seller's instructions, guides and specifications. If Seller provides options of or for Products based upon data or specifications provided by Buyer, Buyer is responsible for determining that such data and specifications are suitable and sufficient for all applications and reasonably foreseeable uses of the Products. In the event Buyer is not the end-user

of the Products, Buyer will ensure such end-user complies with this paragraph.

**13. Use of Products, Indemnity by Buyer.** Buyer shall comply with all instructions, guides and specifications provided by Seller with the Quote or the Products. **Unauthorized Uses.** If Buyer uses or resells the Products in any way prohibited by Seller's instructions, guides or specifications, or Buyer otherwise fails to comply with Seller's instructions, guides and specifications, Buyer acknowledges that any such use, resale, or non-compliance is at Buyer's sole risk. Further, Buyer shall indemnify, defend, and hold Seller harmless from any losses, claims, liabilities, damages, lawsuits, judgments and costs (including attorney fees and defense costs), whether for personal injury, property damage, intellectual property infringement or any other claim, arising out of or in connection with: (a) improper selection, design, specification, application, or any misuse of Products; (b) any act or omission, negligent or otherwise, of Buyer; (c) Seller's use of patterns, tools, equipment, plans, drawings, designs, specifications or other information or things furnished by Buyer; (d) damage to the Products from an external cause, repair or attempted repair by anyone other than Seller, failure to follow instructions, guides and specifications provided by Seller, use with goods not provided by Seller, or opening, modifying, deconstructing, tampering with or repackaging the Products; or (e) Buyer's failure to comply with these Terms. Seller shall not indemnify Buyer under any circumstance except as otherwise provided in these Terms.

**14. Cancellations and Changes.** Buyer may not cancel or modify, including but not limited to movement of delivery dates for the Products, any order for any reason except with Seller's written consent and upon terms that will indemnify, defend and hold Seller harmless against all direct, incidental and consequential loss or damage and any additional expense. Seller, at any time, may change features, specifications, designs and availability of Products.

**15. Limitation on Assignment.** Buyer may not assign its rights or obligations without the prior written consent of Seller.

**16. Force Majeure.** Seller is not liable for delay or failure to perform any of its obligations by reason of events or circumstances beyond its reasonable control. Such circumstances include without limitation: accidents, labor disputes or stoppages, government acts or orders, acts of nature, pandemics, epidemics, other widespread illness, or public health emergency, delays or failures in delivery from carriers or suppliers, shortages of materials, war (whether declared or not) or the serious threat of same, riots, rebellions, acts of terrorism, fire or any reason whether similar to the foregoing or otherwise. Seller will resume performance as soon as practicable after the event of force majeure has been removed. All delivery dates affected by force majeure shall be tolled for the duration of such force majeure and rescheduled for mutually agreed dates as soon as practicable after the force majeure condition ceases to exist. Force majeure shall not include financial distress, insolvency, bankruptcy, or other similar conditions affecting one of the parties, affiliates and/or sub-contractors.

Application Fax Forms
Part Number Index
Safety Guide
Offer of Sale
Application Fax Forms, Part Number Index, Safety Guide, Offer of Sale

**N**



**17. Waiver and Severability.** Failure to enforce any provision of these Terms will not invalidate that provision; nor will any such failure prejudice either party's right to enforce that provision in the future. Invalidation of any provision of these Terms shall not invalidate any other provision herein and, the remaining provisions will remain in full force and effect.

**18. Termination.** Seller may terminate any agreement governed by or arising from these Terms for any reason and at any time by giving Buyer thirty (30) days prior written notice. Seller may immediately terminate, in writing, if Buyer: (a) breaches any provision of these Terms, (b) becomes or is deemed insolvent, (c) appoints or has appointed a trustee, receiver or custodian for all or any part of Buyer's property, (d) files a petition for relief in bankruptcy on its own behalf, or one is filed against Buyer by a third party, (e) makes an assignment for the benefit of creditors; or (f) dissolves its business or liquidates all or a majority of its assets.

**19. Ownership of Software.** Seller retains ownership of all Software supplied to Buyer hereunder. In no event shall Buyer obtain any greater right in and to the Software than a right in the nature of a license limited to the use thereof and subject to compliance with any other terms provided with the Software.

**20. Indemnity for Infringement of Intellectual Property Rights.** Seller is not liable for infringement of any patents, trademarks, copyrights, trade dress, trade secrets or similar rights ("Intellectual Property Rights") except as provided in this Section. Seller will defend at its expense and will pay the cost of any settlement or damages awarded in an action brought against Buyer based on a third party claim that one or more of the Products sold hereunder infringes the Intellectual Property Rights of a third party in the country of delivery of the Products by Seller to Buyer. Seller's obligation to defend and indemnify Buyer is contingent on Buyer notifying Seller within ten (10) days after Buyer becomes aware of any such claim, and Seller having sole control over the defense of the claim including all negotiations for settlement or compromise. If one or more Products sold hereunder is subject to such a claim, Seller may, at its sole expense and option, procure for Buyer the right to continue using the Products, replace or modify the Products so as to render them non-infringing, or offer to accept return of the Products and refund the purchase price less a reasonable allowance for depreciation. Seller has no obligation or liability for any claim of infringement: (i) arising from information provided by Buyer; or (ii) directed to any Products provided hereunder for which the designs are specified in whole or part by Buyer; or (iii) resulting from the modification, combination or use in a system of any Products provided hereunder. The foregoing provisions of this Section constitute Seller's sole and exclusive liability and Buyer's sole and exclusive remedy for claims of infringement of Intellectual Property Rights.

**21. Governing Law.** These Terms and the sale and delivery of all Products are deemed to have taken place in, and shall be governed and construed in accordance with, the laws of the State of Ohio, as applicable to contracts executed and wholly performed therein and without regard to conflicts of laws principles. Buyer irrevocably agrees and consents to the exclusive jurisdiction and venue of the courts of

Cuyahoga County, Ohio with respect to any dispute, controversy or claim arising out of or relating to the sale and delivery of the Products.

**22. Entire Agreement.** These Terms, along with the terms set forth in the main body of any Quote, forms the entire agreement between the Buyer and Seller and constitutes the final, complete and exclusive expression of the terms of sale and purchase. In the event of a conflict between any term set forth in the main body of a Quote and these Terms, the terms set forth in the main body of the Quote shall prevail. All prior or contemporaneous written or oral agreements or negotiations with respect to the subject matter shall have no effect. These Terms may not be modified unless in writing and signed by an authorized representative of Seller.

**23. Compliance with Laws.** Buyer agrees to comply with all applicable laws, regulations, and industry and professional standards, including those of the United States of America, and the country or countries in which Buyer may operate, including without limitation the U.S. Foreign Corrupt Practices Act ("FCPA"), the U.S. Anti-Kickback Act ("Anti-Kickback Act"), U.S. and E.U. export control and sanctions laws ("Export Laws"), the U.S. Food Drug and Cosmetic Act ("FDCA"), and the rules and regulations promulgated by the U.S. Food and Drug Administration ("FDA"), each as currently amended. Buyer agrees to indemnify, defend, and hold harmless Seller from the consequences of any violation of such laws, regulations and standards by Buyer, its employees or agents. Buyer acknowledges that it is familiar with all applicable provisions of the FCPA, the Anti-Kickback Act, Export Laws, the FDCA and the FDA and certifies that Buyer will adhere to the requirements thereof and not take any action that would make Seller violate such requirements. Buyer represents and agrees that Buyer will not make any payment or give anything of value, directly or indirectly, to any governmental official, foreign political party or official thereof, candidate for foreign political office, or commercial entity or person, for any improper purpose, including the purpose of influencing such person to purchase Products or otherwise benefit the business of Seller. Buyer further represents and agrees that it will not receive, use, service, transfer or ship any Products from Seller in a manner or for a purpose that violates Export Laws or would cause Seller to be in violation of Export Laws. Buyer agrees to promptly and reliably provide Seller all requested information or documents, including end-user statements and other written assurances, concerning Buyer's ongoing compliance with Export Laws.

Application Fax Forms	Part Number Index	Safety Guide	Offer of Sale	Application Fax Forms, Part Number Index, Safety Guide, Offer of Sale
-----------------------	-------------------	--------------	---------------	---





Parker Hannifin Corporation

**Pneumatic Division**

135 Quadral Drive

Wadsworth, OH 44281 USA

Tel: 269 629 5000

Applications Engineering: [pdnapps@parker.com](mailto:pdnapps@parker.com)

Customer Support: [pdncustsvc@parker.com](mailto:pdncustsvc@parker.com)

Web site: [www.parker.com/pneumatics](http://www.parker.com/pneumatics)

